

ASSEMBLY INSTRUCTIONS

CHEVAL MIRROR WALNUT

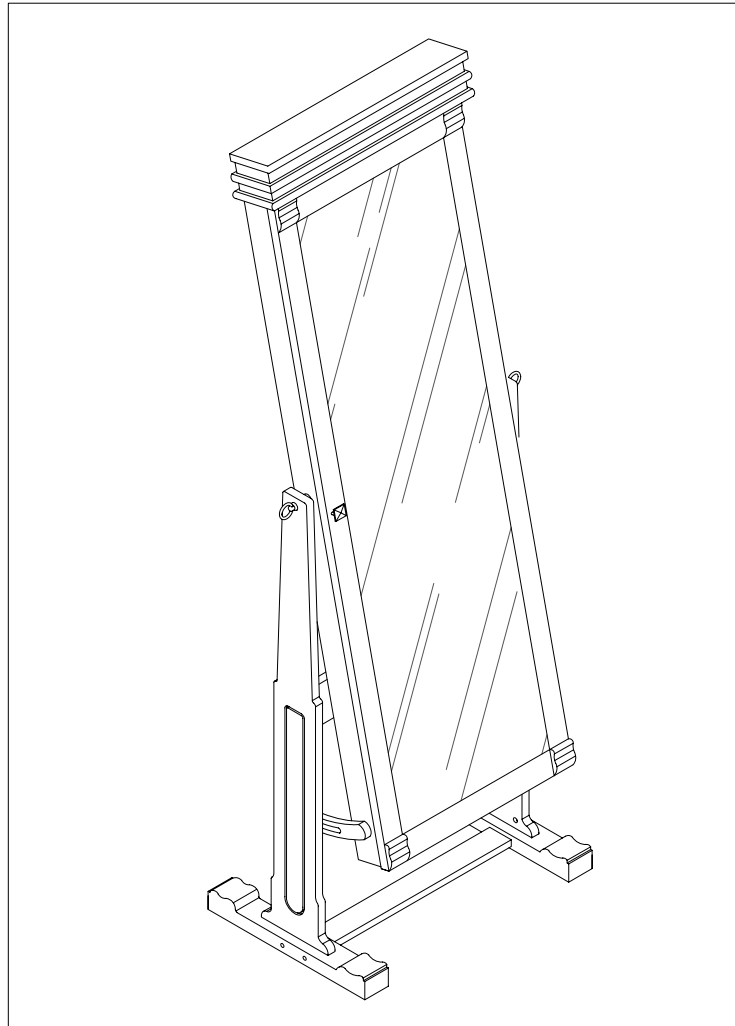

MADE IN CHINA

PARTS IDENTIFICATION



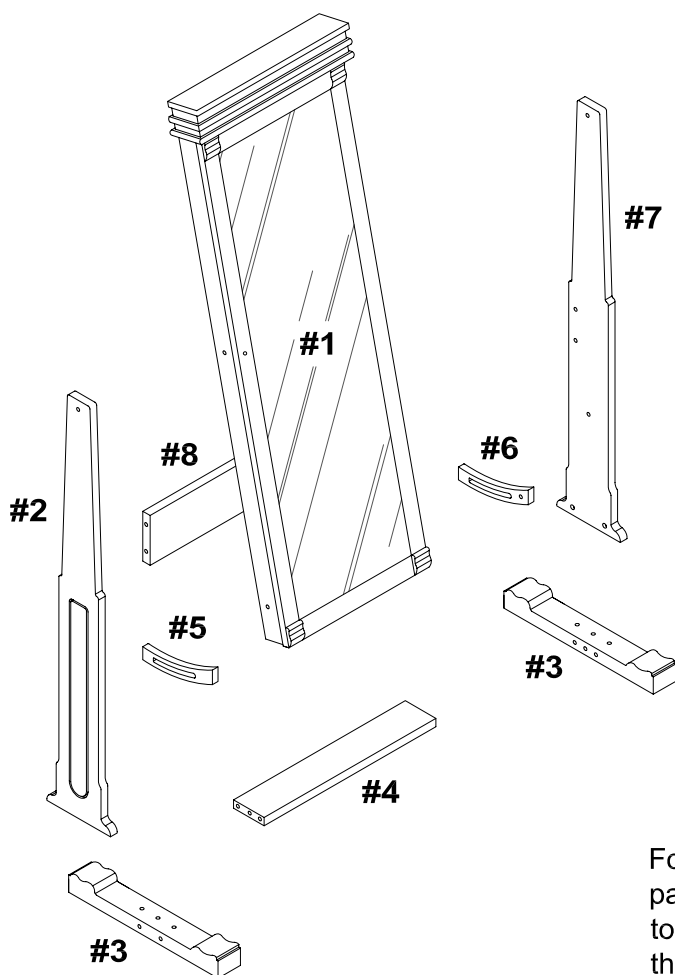



| ITEM | DESCRIPTION | QTY |
|------|-----------------|-----|
| #1 | ARMOIRE CABINET | 01 |
| #2 | LEFT PANEL | 01 |
| #3 | LEG | 02 |
| #4 | CROSS BAR | 01 |
| #5 | LEFT BLOCK | 01 |
| #6 | RIGHT BLOCK | 01 |
| #7 | RIGHT PANEL | 01 |
| #8 | RAIL | 01 |

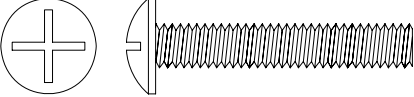
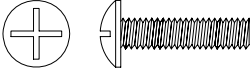
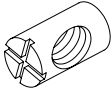

For ease of identification all parts are labeled to correspond to the Step number in which the part is used.

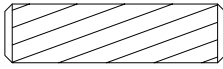

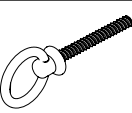
HARDWARE IDENTIFICATION

Please line up the hardware with the correct full size image to make sure you are installing the hardware correctly.

| ITEM | PICTURE | DESCRIPTION | QTY |
|------|---|---------------------------------|--------------------|
| A |  | (Ø1/4"x2-1/2"L) Not to Scale | BOLT 08 |
| B |  | (Ø5/32"x3/4"L) Full size | BOLT 01 |
| C |  | (Ø1/4") Not to Scale | NUT 08 |
| D |  | (Ø16mm) Not to Scale | FLAT WASHER 02 |
| F |  | (Ø8mmx30mm) Full size | WOODEN DOWEL 04 |
| G |  | Not to Scale | BLOCK 02 |
| H |  | Not to Scale | BOLT 02 |
| I |  | (Ø19mm) Not to Scale | FLAT WASHER 02 |
| J |  | (Ø19mm) Not to Scale | HANDLE 01 |

HARDWARE IDENTIFICATION

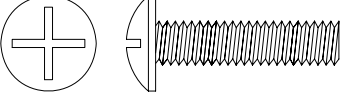
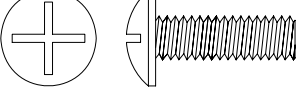
Please line up the hardware with the correct full size image to make sure you are installing the hardware correctly.

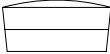
| ITEM | PICTURE | DESCRIPTION | QTY |
|------|---|-----------------------------------|---|
| K |  | (Ø1/4"x1"L) Full size | BOLT 02 |
| L |  | (Ø1/4"x3/4"L) Full size | BOLT 02 |
| M |  | (Ø1/4") Not to Scale | CAM BOLT 04 |
| N |  | Not to Scale | CAM LOCK 04 |
| P |  | Not to Scale | WOOD HOLE COVER 04 |

STEP 1.

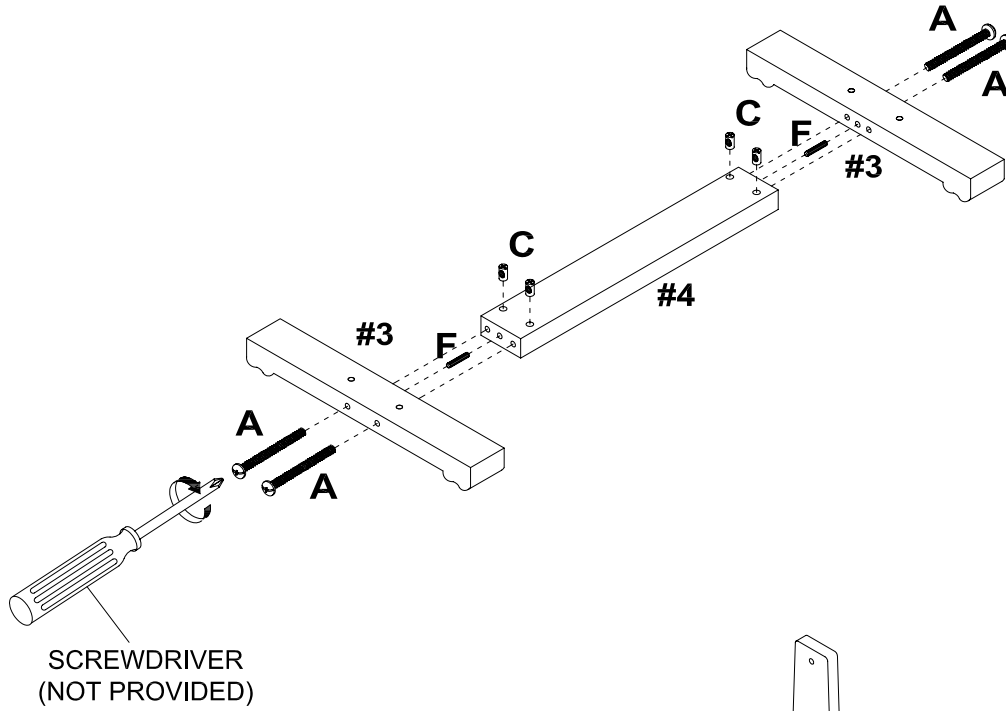

STEP 2.

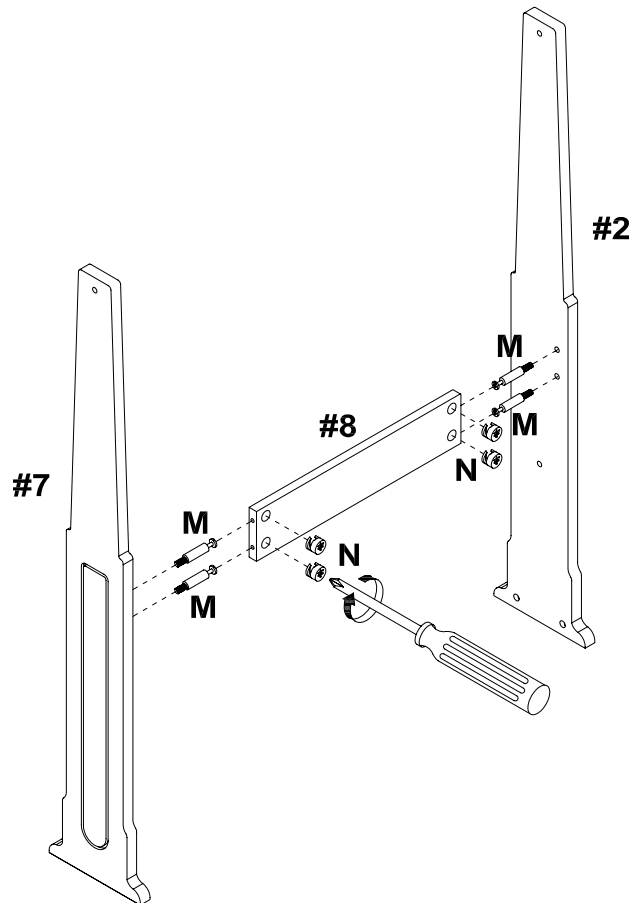

IMPORTANT:

1. DO NOT TIGHTEN BOLTS COMPLETELY UNTIL ALL BOLTS ARE COMPLETELY LINED UP AND INSERTED INTO HOLES / NUTS.
2. DO NOT OVER TIGHTEN SCREWS AND BOLTS TO AVOID STRIPPING.

STEP 3.

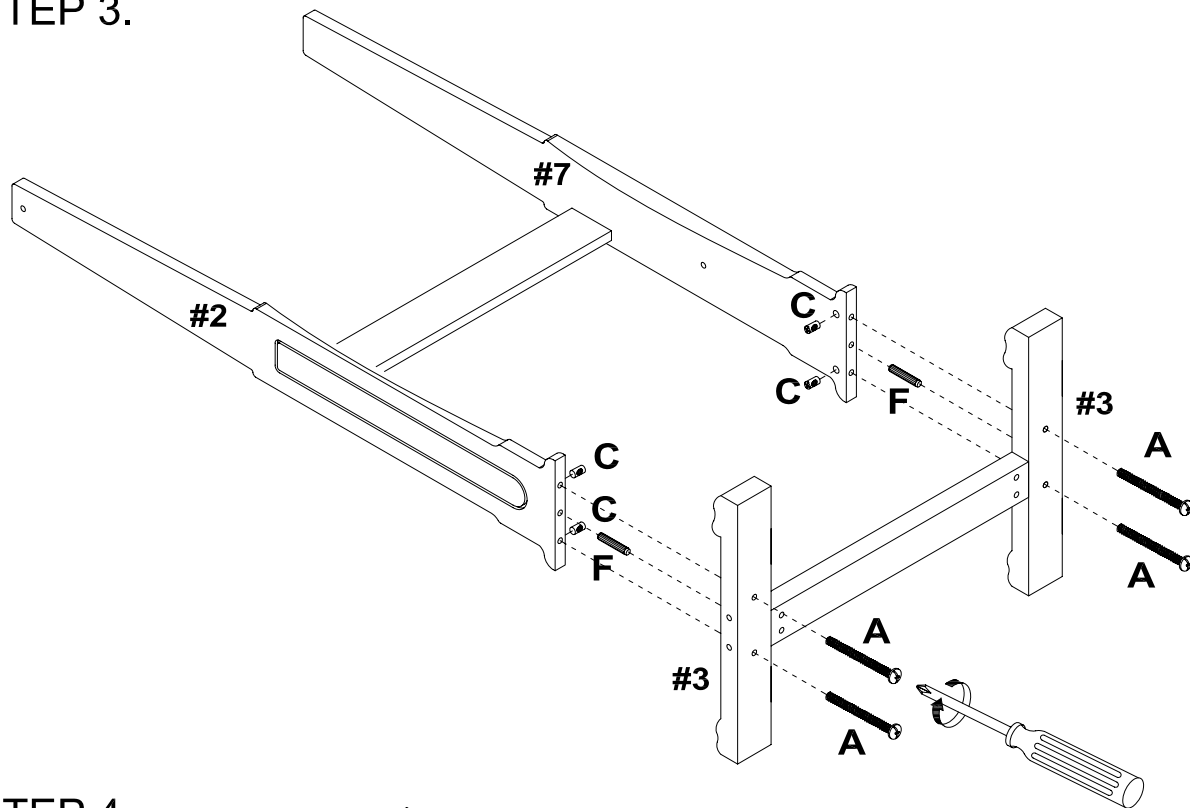

STEP 4.

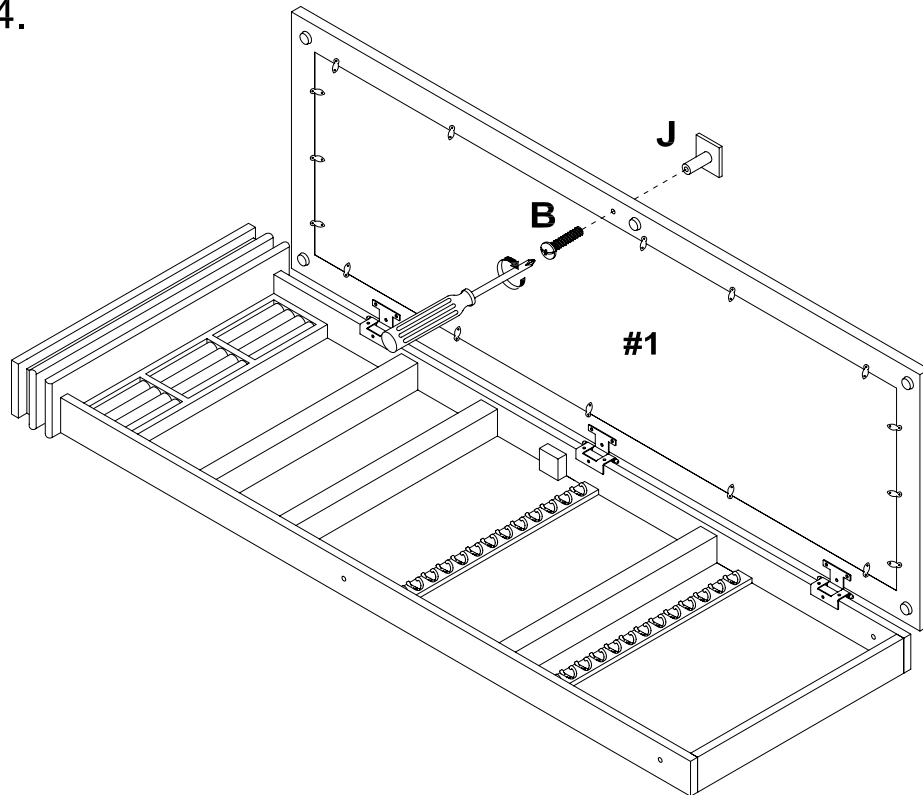

IMPORTANT:

1. DO NOT TIGHTEN BOLTS COMPLETELY UNTIL ALL BOLTS ARE COMPLETELY LINED UP AND INSERTED INTO HOLES / NUTS.
2. DO NOT OVER TIGHTEN SCREWS AND BOLTS TO AVOID STRIPPING.

STEP 5.

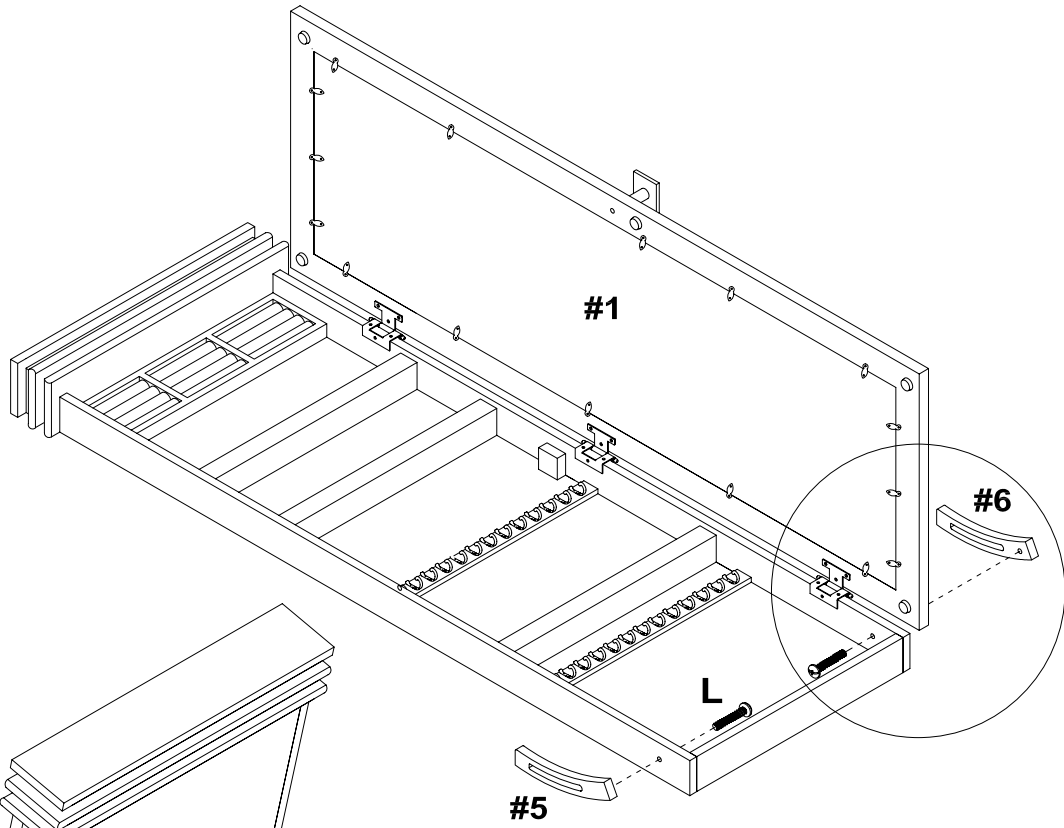

STEP 6.

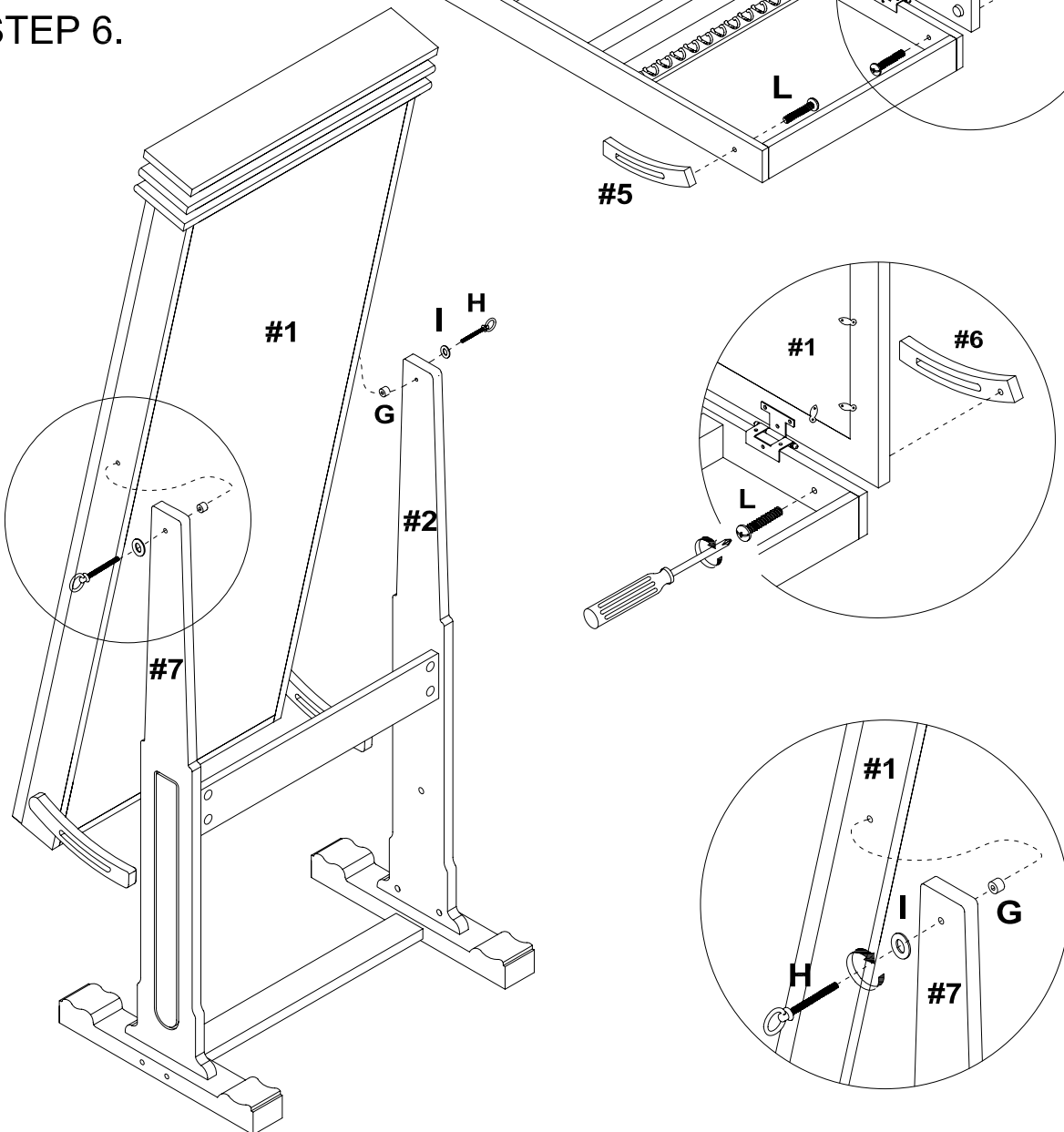

STEP 7.

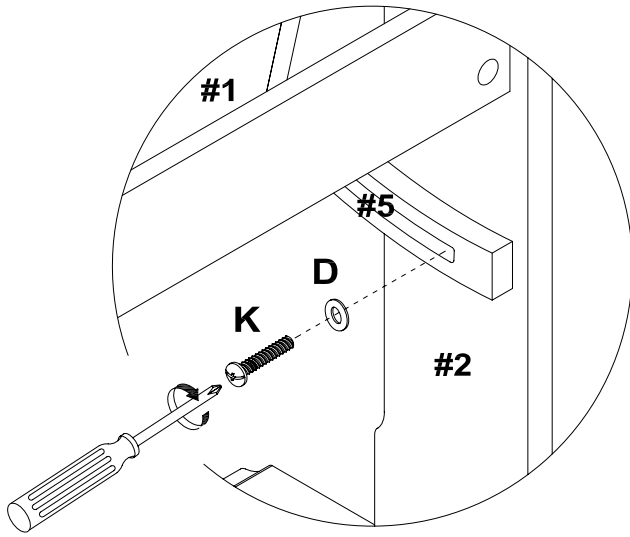

STEP 8.

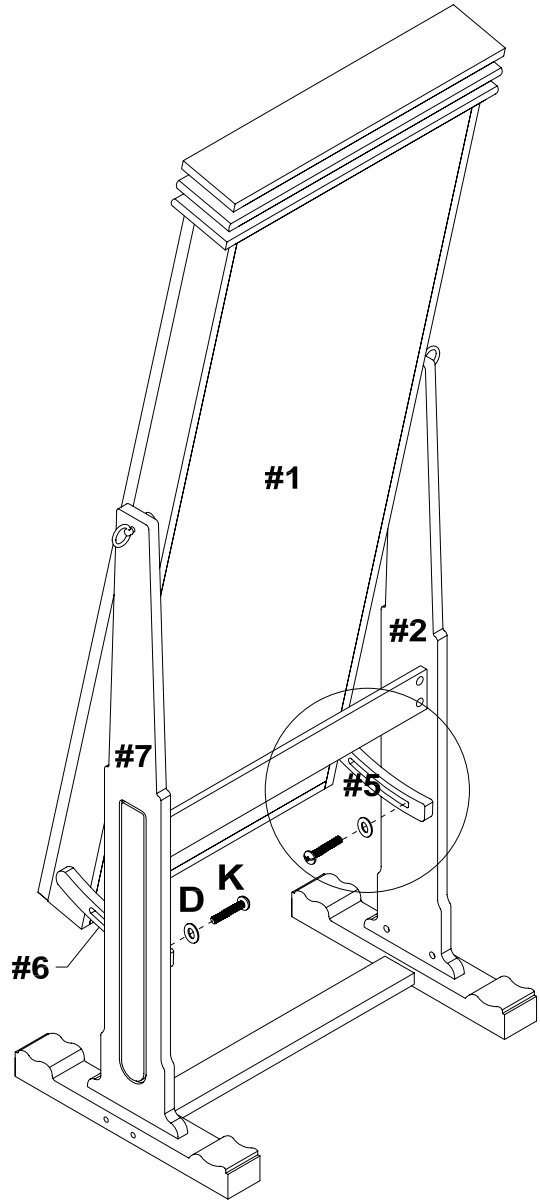
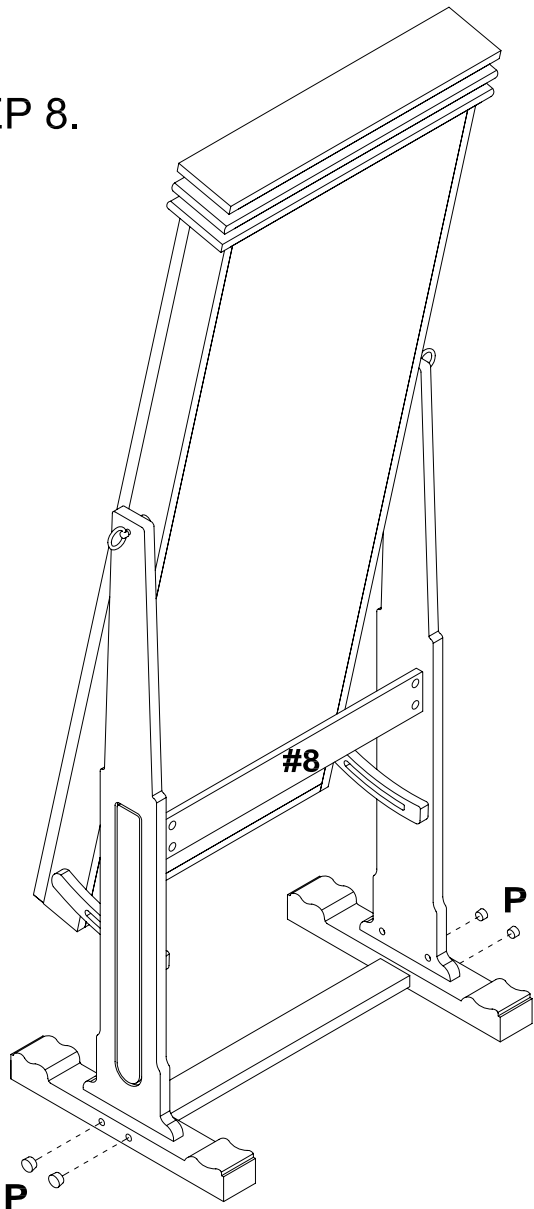

WARRANTY