

ASSEMBLY INSTRUCTIONS



Fine Furniture for every stage of life

Side Chair

ASSEMBLY INSTRUCTIONS

ASSEMBLY TIPS:

1. Remove hardware from box and sort by size.
2. Please check to see that all hardware and parts are present prior to start of assembly.
3. Please follow attached instructions in the same sequence as numbered to assure fast & easy assembly.



WARNING!





1. Don't attempt to repair or modify parts that are broken or defective. Please contact the store immediately.
2. This product is for home use only and not intended for commercial establishments.





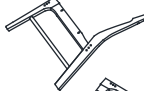







ASSEMBLY TIME

15 MINUTES

PARTS IDENTIFICATION

A	BACKREST		1PC
B	LEFT LEG		1PC
C	RIGHT LEG		1PC
D	FRONT RAIL		1PC
E	BACK RAIL (MARKING HOLE)		1PC
F	SEAT		1PC

HARDWARE IDENTIFICATION

1	ALLEN WRENCH (M4 X 100MM - RBW)		1PC
2	LONG BOLT (M6 X 60MM - RBW)		6PCS
3	SHORT BOLT (M6 X 30MM - RBW)		4PCS
4	LOCK WASHER (M6 X 13MM - RBW)		10PCS
5	FLAT WASHER (M6 X 13MM - RBW)		10PCS
6	FLAT HEAD SCREW (M4 X 30MM)		4PCS
7	BIG WOOD DOWEL (M8 X 30MM)		4PCS
8	SMALL WOOD DOWEL (M8 X 25MM)		1PC
9	WOOD BUTTON (14.5MM)		4PCS
10	FELT PAD (3 X 21MM)		4PCS

NOTE :

Phillips head screw driver is required in the assembly process; however, manufacturer does not provide this item. Quantities shown are for one chair.

ASSEMBLY INSTRUCTIONS

STEP 1

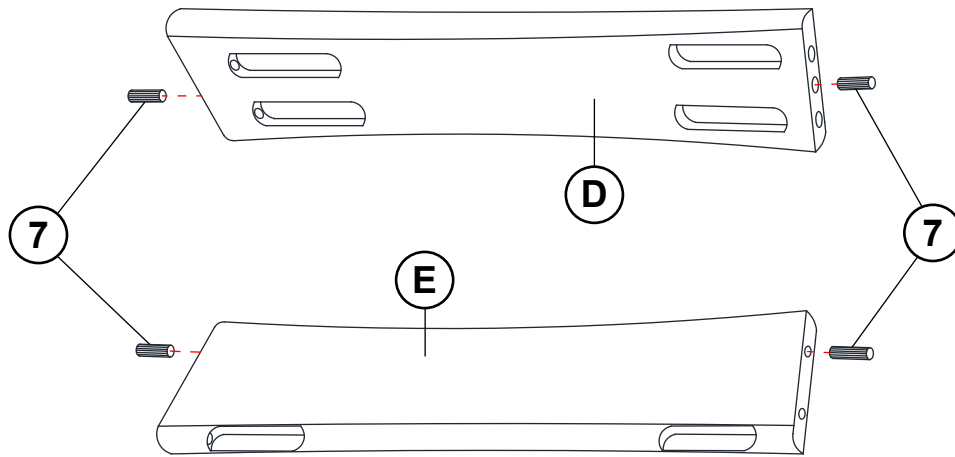

STEP 2

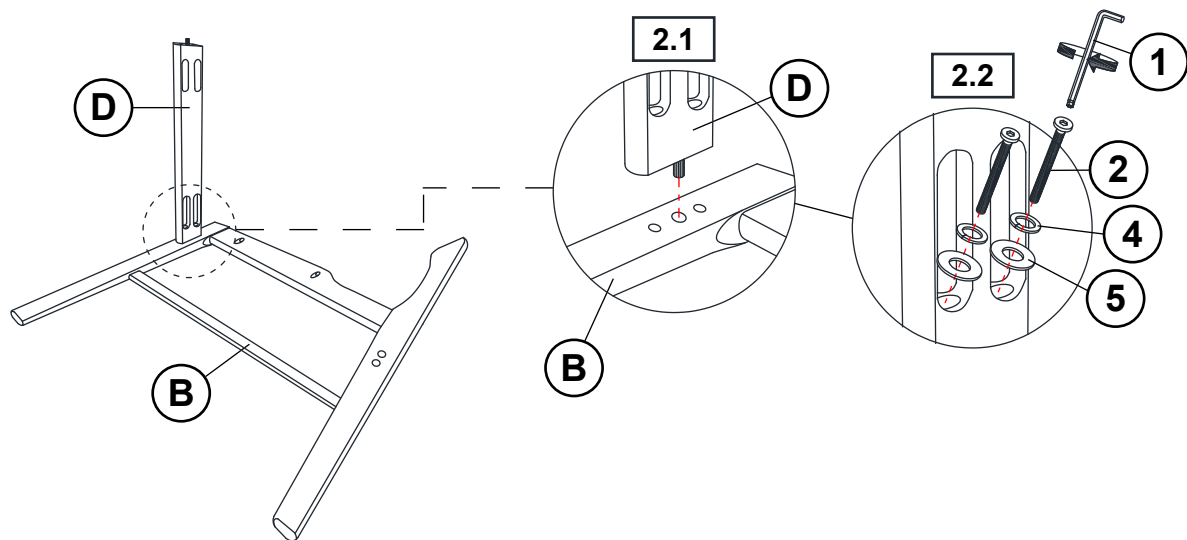

STEP 3

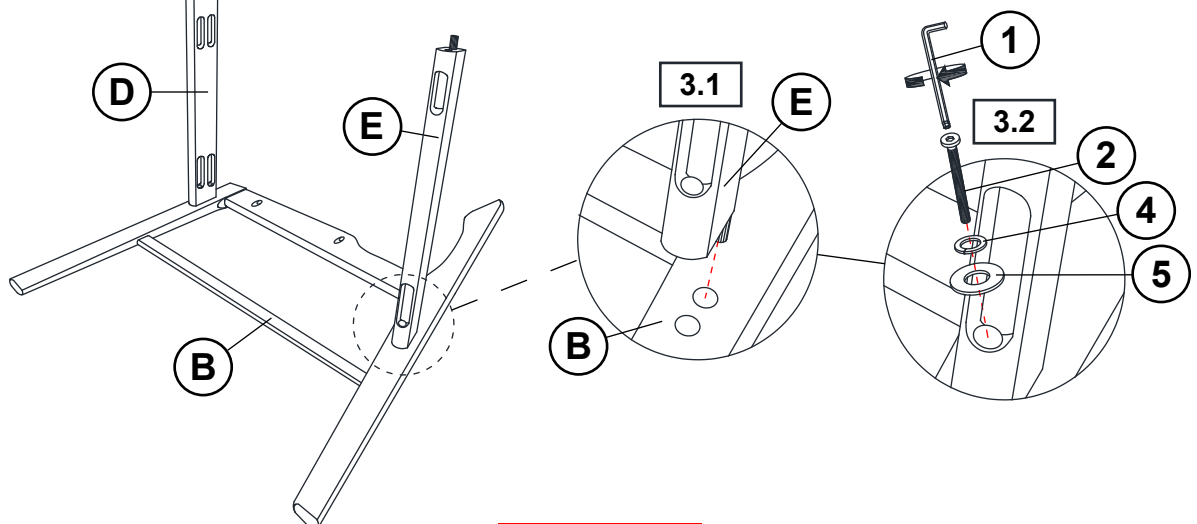

ASSEMBLY INSTRUCTIONS

STEP 4

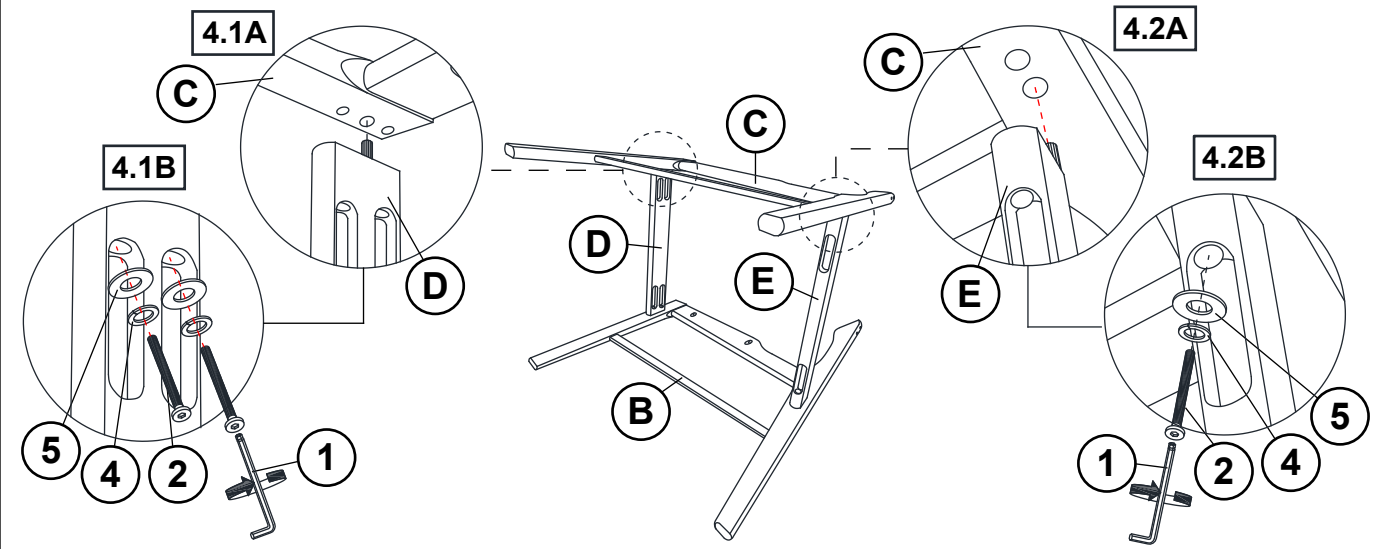

STEP 5

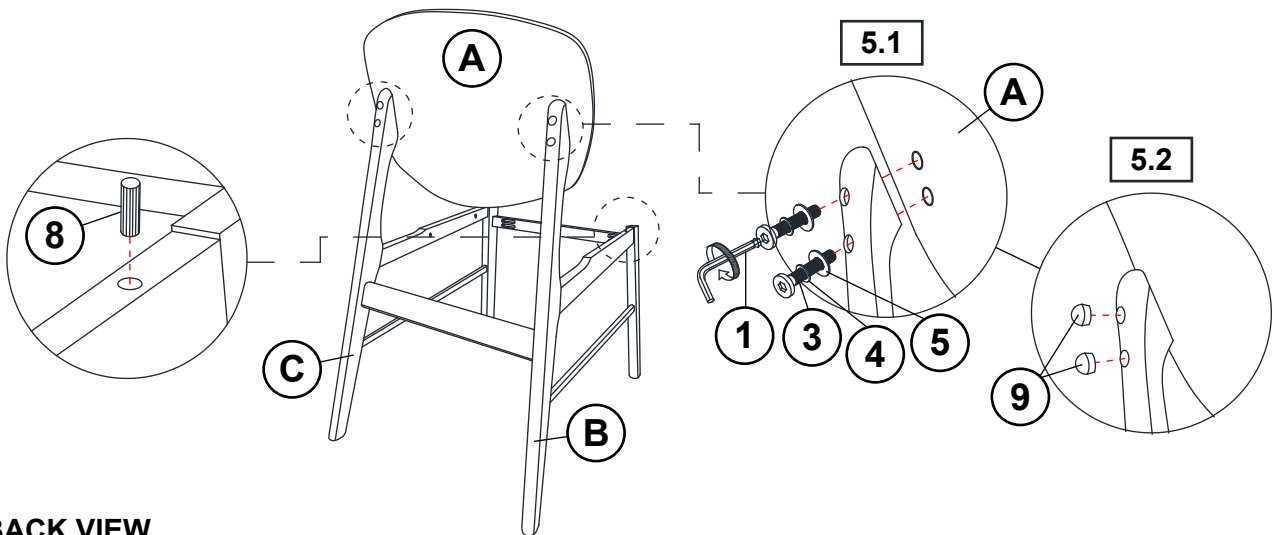

*BACK VIEW

STEP 6

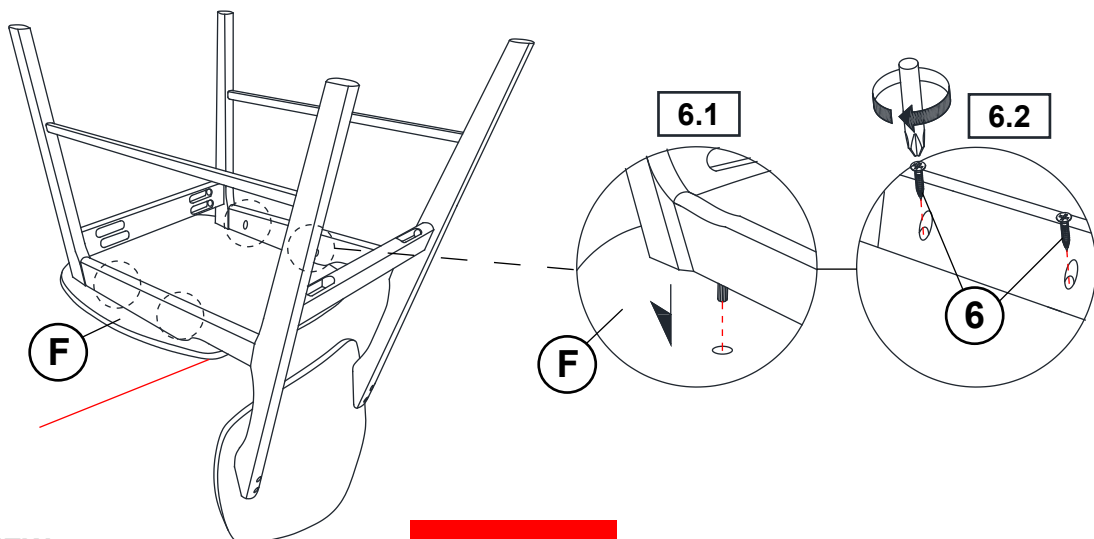

*BOTTOM VIEW

ASSEMBLY INSTRUCTIONS

STEP 7

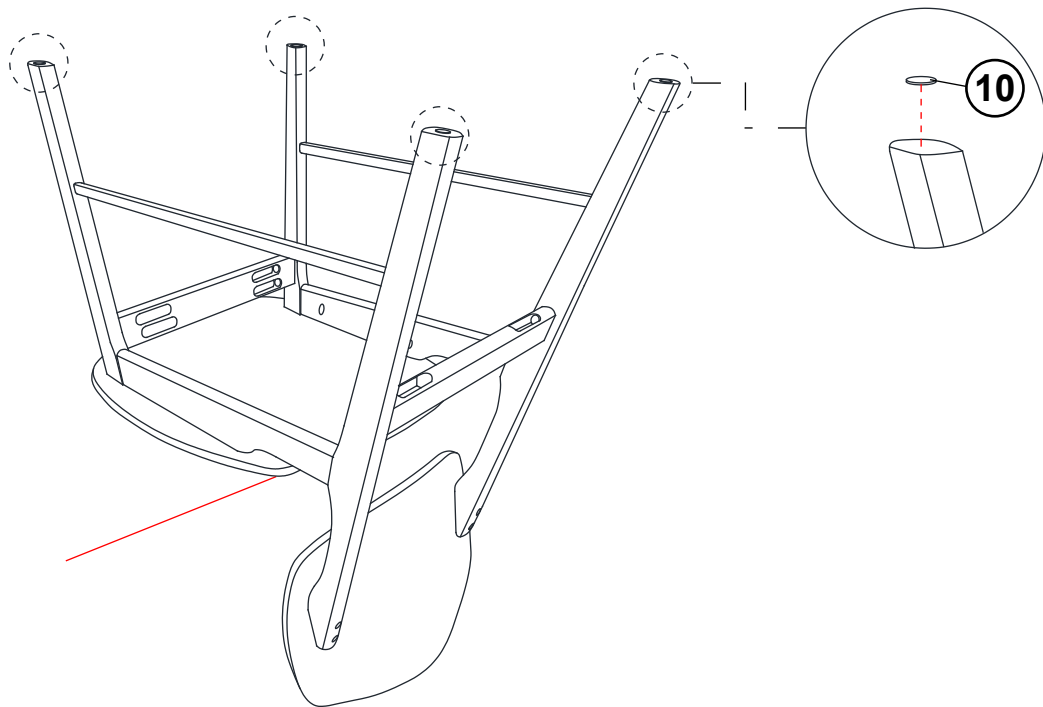

*BOTTOM VIEW

STEP 8 COMPLETE

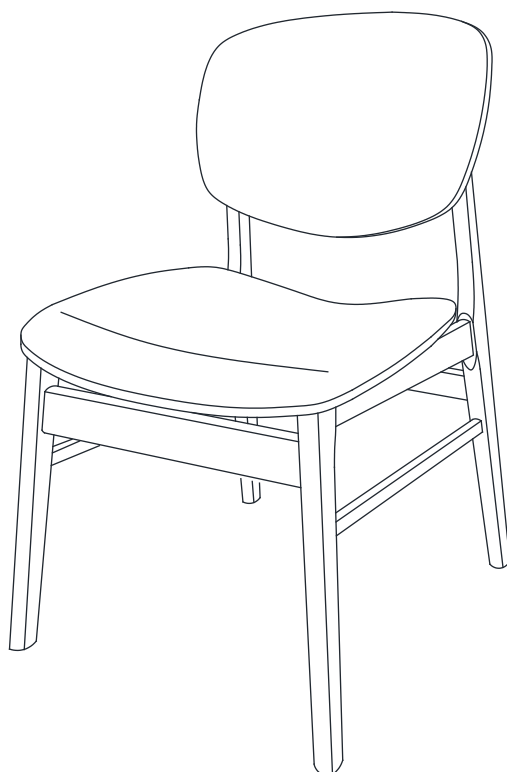

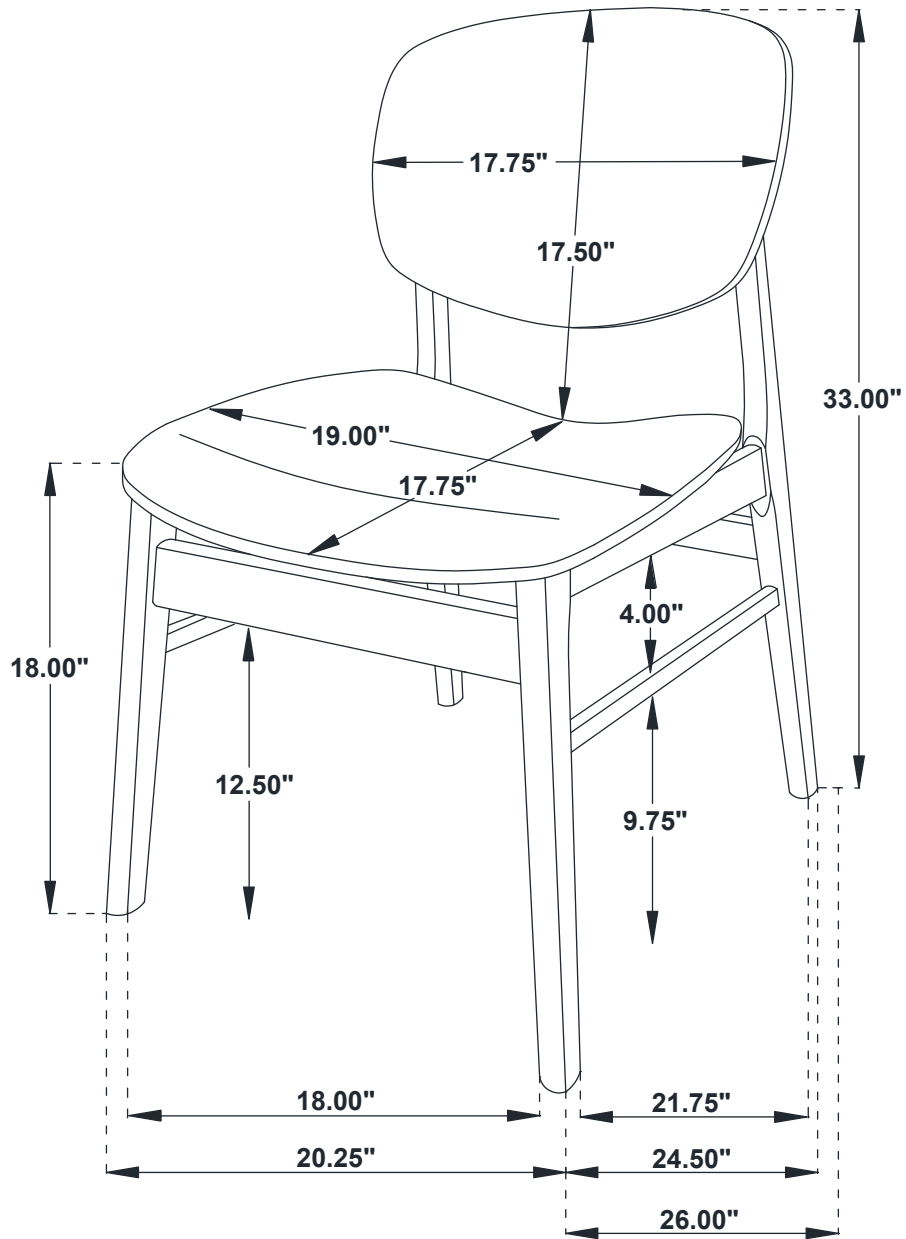

Note: Dimension tolerance $\pm 5\%$