

ASSEMBLY INSTRUCTIONS

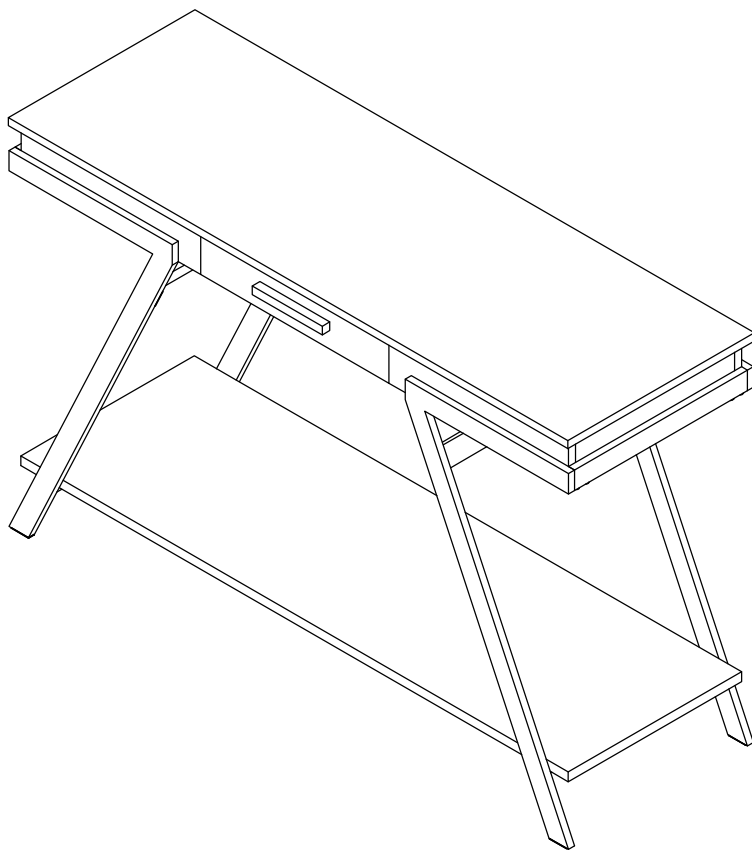

TOOLS REQUIRED

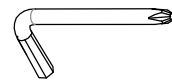

Allen Wrench
(Included)



2 - People
Recommended

ASSEMBLY RATING



EASY —————> DIFFICULT

The Assembly Rating is a 5-point system showing the level of effort needed to assemble a specific product.



CHECK BEFORE STARTING

Are you missing anything?

Double-check all parts, hardware and accessories listed are all accounted for.

Check out our Quick Tips!

We recommend reviewing the pre-assembly handouts. Even experts need a refresher now and then!

Should we send any replacements?

Are there any irregularities or flaws in the parts? We can send replacements!

Prep Time!

Please review the assembly instructions and all diagrams prior to assembling.

PRE ASSEMBLY INTRODUCTION

We understand building ready-to-assemble furniture can be a challenging experience for some. To help avoid confusion, we have provided some helpful tips that may speed up the process.



Teamwork

ALWAYS have at least two people to help with transporting and assembling the product to avoid potential injury and/or damage.



Suitable Location

Assembling near the area of the intended location is highly recommended.



Sufficient Space

Make sure you have enough space to move around during the assembly.



Avoid Scratches

Use cardboard, blankets or a carpeted area while assembling furniture to prevent to prevent scratches and damages.



Flat Surface

Make sure the furniture rests on a flat and level surface with each leg evenly touching the floor.

ASSEMBLY AND CARE ADVICE



FAILURE TO FOLLOW THE GUIDELINES BELOW MAY RESULT IN INJURY AND/OR PROPERTY DAMAGE.



Position each part correctly and insert screws or bolts into their respective holes.



Turn clockwise to tighten and only tighten when step is completed or when instructed to do so.



Use the appropriate hand tools or power tools for assembly. Select steps, such as tightening screws and/or bolts, may require hand tools to avoid causing damage during assembly.



Save the instructions and store any supplied tools for later maintenance.



After two weeks, check and tighten any loose hardware and repeat again every six months thereafter.

IT IS THE USER'S RESPONSIBILITY TO MAINTAIN THE FURNITURE. THE HARDWARE MAY LOOSEN OVER TIME AND MAY CAUSE THE FURNITURE TO BE WOBBLY AND UNABLE TO SUPPORT ITS INTENDED WEIGHT CAPACITY. THIS MAY LEAD TO COLLAPSE AND MAY CAUSE SERIOUS INJURY.

SOFA TABLE



- Please keep instructions for future reference.
- Check the quantity and irregularity of parts and hardware before you start.

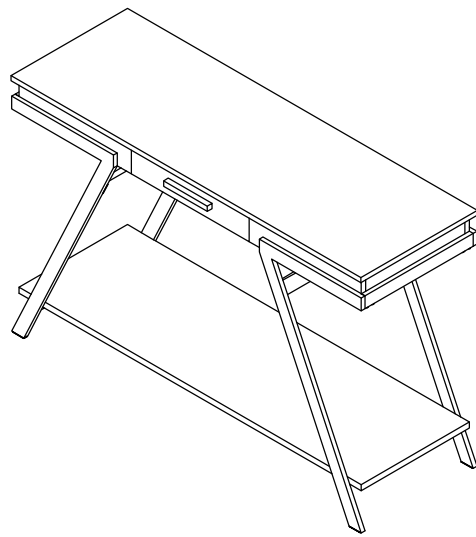

PARTS

#1 1pc

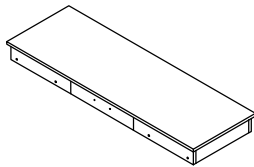

TOP BOX

#2 1pc

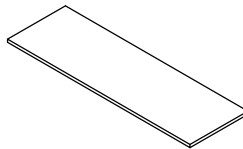

SHELF

#3 2pcs



LEG 1

#4 2pcs



LEG 2

#5 2pcs

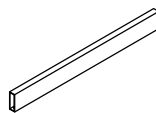

TOP CROSSBAR

#6 2pcs

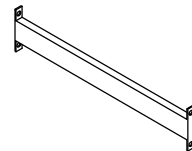

SUPPORT CROSSBAR

#7 2pcs

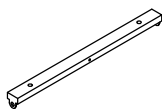

BOTTOM CROSSBAR

#8 1pc

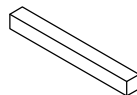

HANDLE

#9 1pc

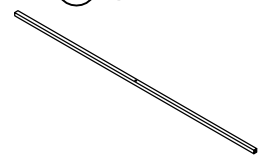

BOTTOM SUPPORT CROSSBAR

SOFA TABLE



- Please keep instructions for future reference.
- Check the quantity and irregularity of parts and hardware before you start.

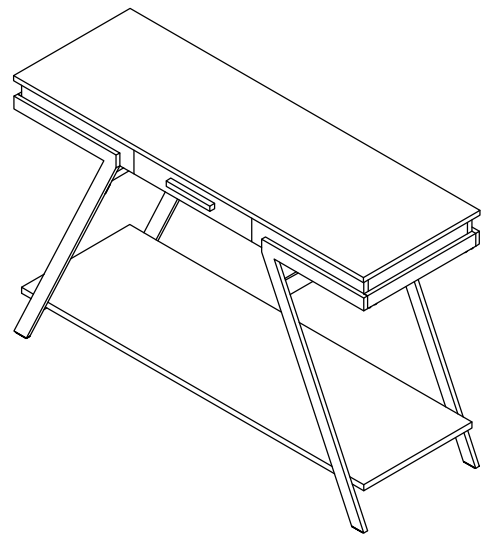

HARDWARE

#A 20pcs



Short Bolt 1/4" x 9mm

#B 12pcs



Bolt 1/4" x 22mm

#C 2pcs

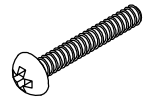

Handle Bolt ϕ 3/16" x 25mm

#D 4pcs

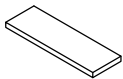

Felt Pad

#E 2pcs



Long Bolt 1/4" x 47mm

#F 1pc



Screw 4 x 25mm

#G 1pc

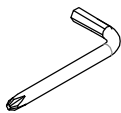

Allen Wrench 4mm

ASSEMBLY INSTRUCTIONS

1

- Part #3 x2pcs
- Part #4 x2pcs
- Part #5 x2pcs
- Part #6 x2pcs
- Part #7 x2pcs
- Hardware #A x20pcs
- Hardware #D x4pcs

- I. Align the Top Crossbar (#5) to the Leg 1 (#3) and Leg 2 (#4). Secure using Short Bolt (#A).
- I. Align the Support Crossbar (#6) to the Leg1 (#3) and Leg 2 (#4). Secure using Short Bolts(#A).
- II. Align the Bottom Crossbar (#7) to the Leg1 (#3) and Leg 2 (#4). Secure using Short Bolt (#A).
- IV. Add Felt pads (#D) to Leg 1 (#3) and Leg 2 (#4).

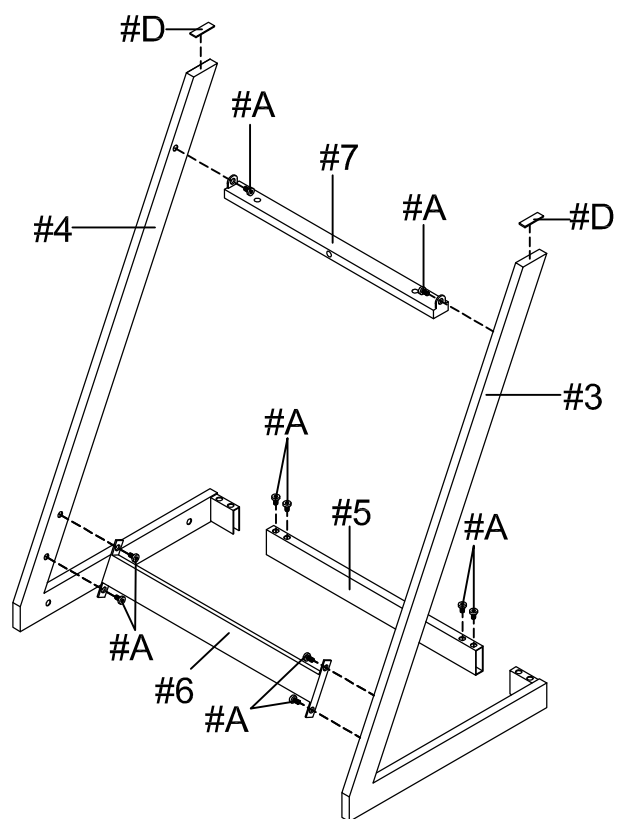
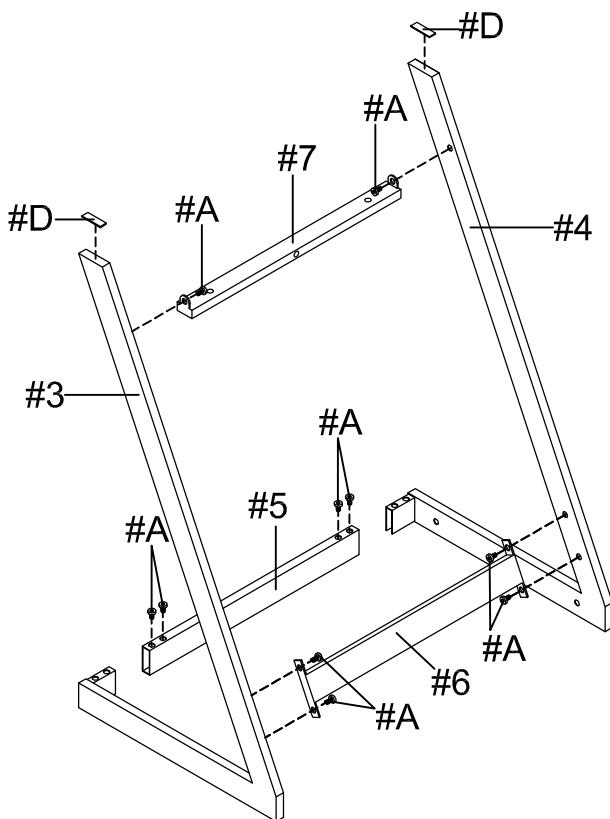

ASSEMBLY INSTRUCTIONS

2

- Part #1 x1pc
- Part #9 x2pcs
- Hardware #B x8pcs
- Hardware #E x2pcs

Align both legs to the Top Box (#1) and secure with Short Bolt (#B). Then align the Bottom Support Crossbar (#9) to the bottom of the legs and secure using Long Bolt (#E).

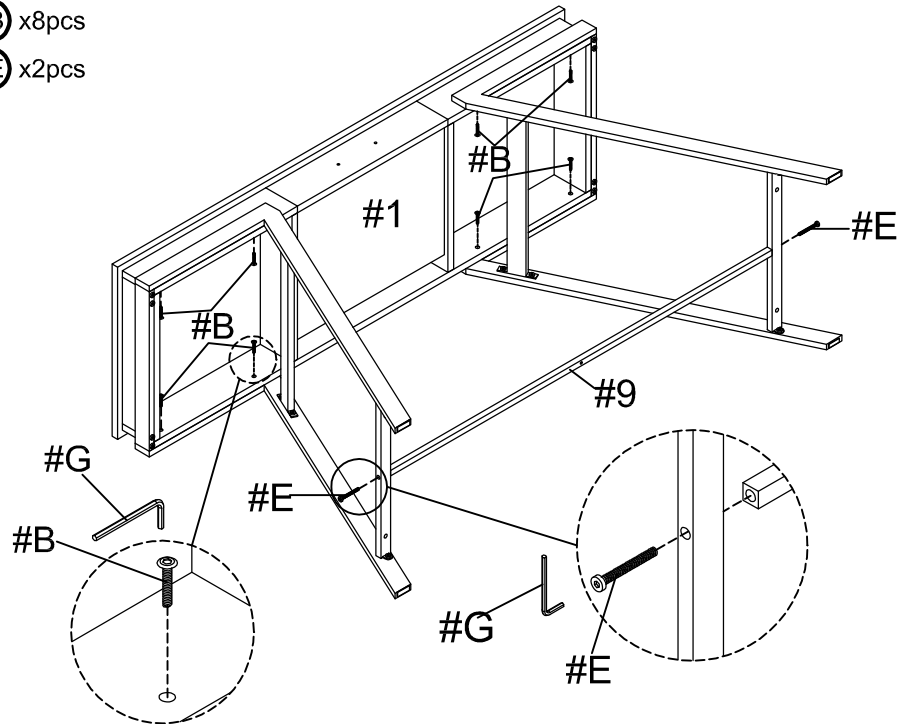

3

- Part #2 x1pc
- Hardware #B x4pcs
- Hardware #F x1pc

Align the Shelf (#2) to the Legs and Bottom Support Crossbar (#9) and secure at the legs using Bolt (#B). Secure at the crossbar using Screw (#F).

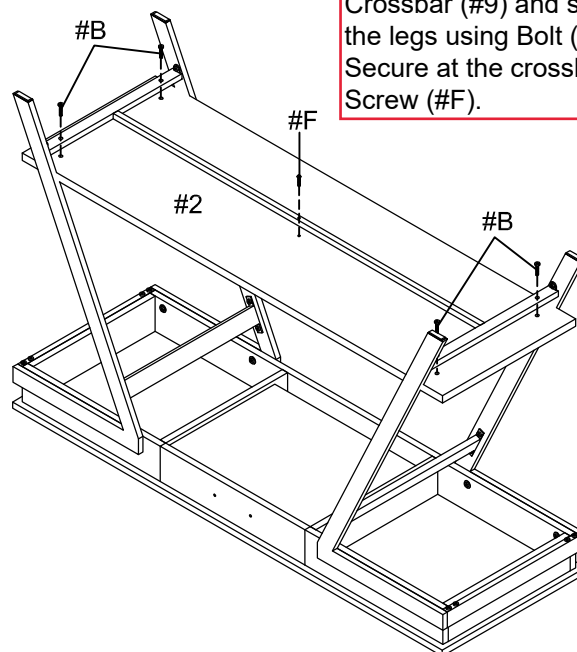

ASSEMBLY INSTRUCTIONS

4

Part **#8** x1pc
Hardware **#C** x2pcs

Align and secure handle onto the drawer front using Handle Bolt (#C).

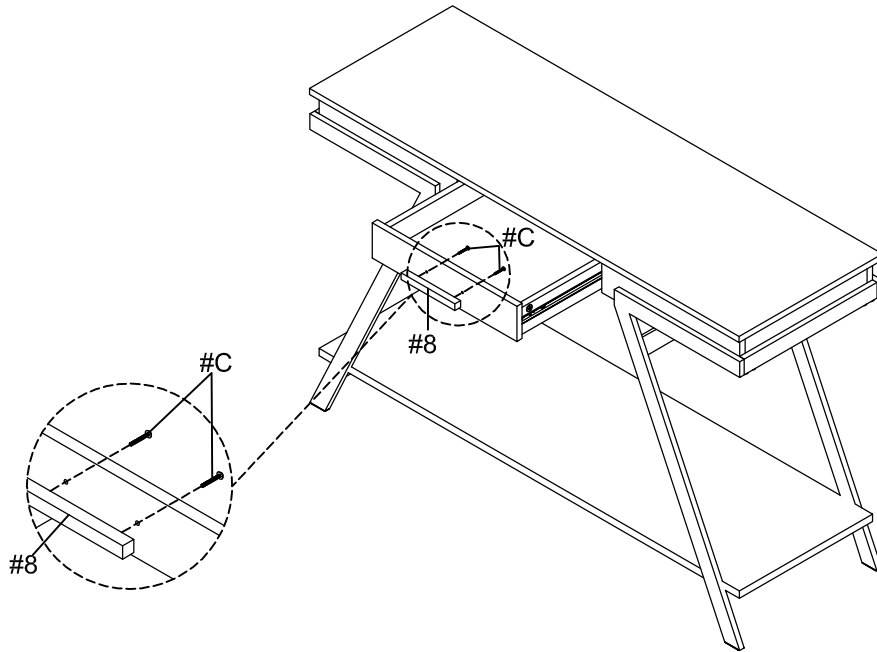

5

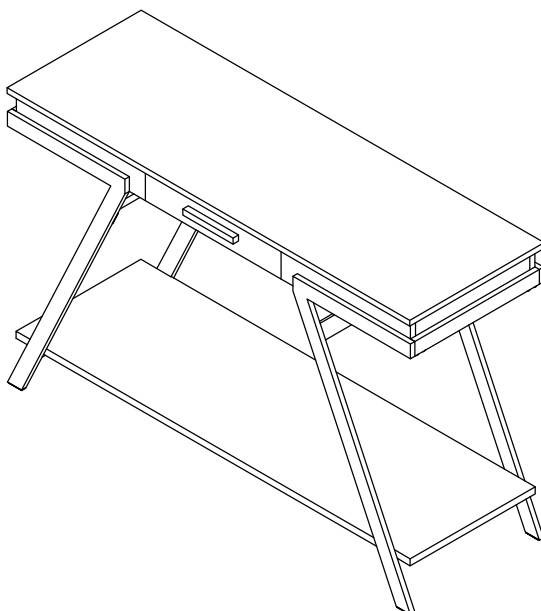

ASSEMBLY COMPLETED



Please ensure the furniture rests on an even and flat surface. If the product wobbles or feels loose, double-check all bolts and/or screws are properly tightened and secured.



Keep this handy!

Please retain this instruction manual and any order-related information for future reference.



Lift, don't drag!

To avoid damage to product please always LIFT the product when transporting or adjusting the placement.