

INSTRUCTION MANUAL MANUEL D'INSTRUCTIONS

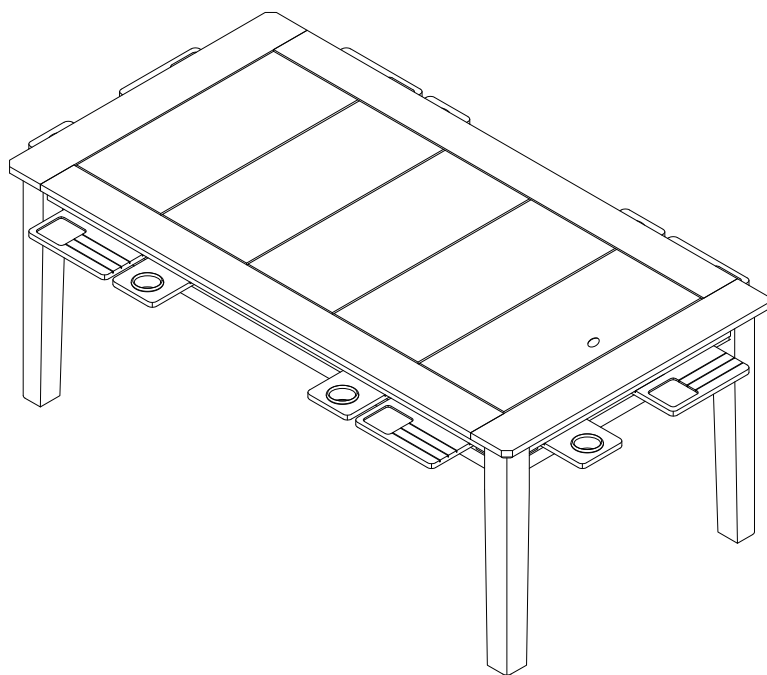

BOARD GAME TABLE
TABLE DE JEUE SOCIÉTÉ

English

CUSTOMER SERVICE LETTER

If you have any concerns about the product, feel free to contact us via **customerservice@lausaint.com** with following details. We will respond within 24 working hours.

1. Purchase platform and order ID.
2. Product name or SKU.
3. Traceability code (e.g., YQxxYxxW) from the carton or product.
4. Close-up photos of damaged packaging, faulty parts, or missing components (mark issues on the manual).

IMPORTANT

Read through each step carefully and follow the proper order separate and count all your parts and hardware.

Give yourself enough room for the assembly process.

Have the following tools: Flat Head Screwdriver, Phillips Head Screwdriver and Hammer

Caution: If using a power drill or power screwdriver for screwing. Please be aware of slowing down and stop when screw is tight. Failure to do so may result in stripping the screw.

(Assembly speed can be increased by using electric screwdriver)

As this item contains many parts, please read the installation instruction carefully before installation. Please use tools properly and carefully.



WARNINGS

PEOPLE NEEDED FOR ASSEMBLY: 1-2

- Open your item in the area you plan to keep it to avoid excessive heavy lifting.
- Identify, sort and count the parts before attempting assembly.



- Compression dowels are lightly taped in with a hammer.
- Slides are labeled with an R (right) and L (left) for proper placement.
- Make sure to always face the point on the top of the Cam Lock towards the outer edge.
- If there is a back panel in the package, please install it to make sure your unit is complete and sturdy.
- Please fix all the screws provided for the back panel which can enhance product stability. If it difficult to fix it when tightening, it can be fixed with the help of a hammer and then tightened.
- DO NOT use harsh chemicals or abrasive cleaners on this item.
- Never push,pull,or drag your furniture.



Français

✉ CUSTOMER SERVICE LETTER

Si vous avez des questions ou des préoccupations concernant le produit, n'hésitez pas à nous contacter à **customerservice@lausaint.com** en fournissant les informations suivantes. Nous vous répondrons sous 24 heures ouvrables.

1. Plateforme d'achat et numéro de commande.
2. Nom du produit ou SKU.
3. Code de traçabilité (par exemple : YQxxYxxW) figurant sur le carton ou le produit.
4. Photos rapprochées des emballages endommagés, des pièces défectueuses ou des composants manquants (indiquez les problèmes sur le manuel).

⚠ IMPORTANT

Lisez attentivement chaque étape et suivez l'ordre approprié. Séparez et comptez toutes vos pièces et la quincaillerie.

Prévoyez suffisamment d'espace pour le processus de montage.

Ayez les outils suivants à disposition: tournevis plat, tournevis cruciforme et marteau.

Attention: si vous utilisez une perceuse ou un tournevis électrique, ralentissez et arrêtez lorsque la vis est bien serrée. Le non-respect de cette consigne pourrait endommager la vis.

(La vitesse de montage peut être augmentée à l'aide d'un tournevis électrique.)

Comme cet article contient de nombreuses pièces, veuillez lire attentivement les instructions d'installation avant de commencer. Veuillez utiliser les outils correctement et prudemment.



AVERTISSEMENTS

NOMBRE DE PERSONNES NÉCESSAIRES POUR L'ASSEMBLAGE: 1 À 2

- Déballez votre article dans la zone où vous prévoyez de l'installer pour éviter de soulever des charges lourdes inutilement.
- Identifiez, trie et comptez les pièces avant de commencer l'assemblage.
- Les chevilles de compression doivent être légèrement enfoncées avec un marteau.
- Les glissières sont étiquetées avec un R (droite) et un L (gauche) pour assurer un placement correct.
- Assurez-vous que la flèche sur le dessus du verrou à came est toujours orientée vers le bord extérieur.
- S'il y a un panneau arrière dans l'emballage, veuillez l'installer pour que l'unité soit complète et stable.
- Veuillez fixer toutes les vis fournies pour le panneau arrière, ce qui renforcera la stabilité du produit. Si cela est difficile à serrer, vous pouvez utiliser un marteau pour aider à le fixer avant de visser.
- NE PAS utiliser de produits chimiques agressifs ou de nettoyeurs abrasifs sur cet article.
- Ne jamais pousser, tirer ou traîner le meuble.



Component List/ Liste des composants

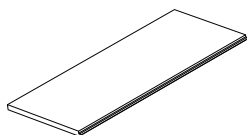

① x 1

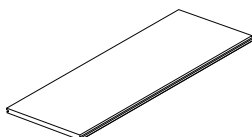

② x 3

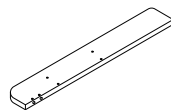

③ x 2

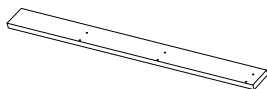

④ x 2

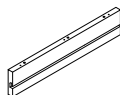

⑤ x 2

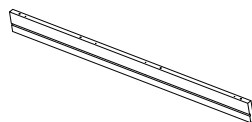

⑥ x 2

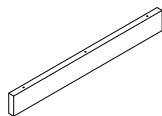

⑦ x 2



⑧ x 4

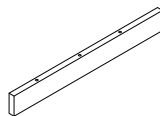

⑨ x 2

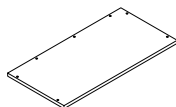

⑩ x 2

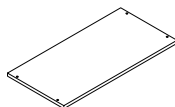

⑪ x 3

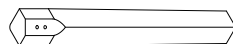

⑫ x 4

Component List/ Liste des composants

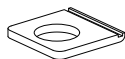

⑬ x 6

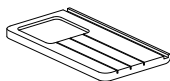

⑭ x 6



⑮ x 6



⑯ x 1

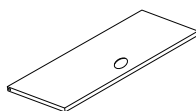

⑰ x 1



A x (16 + 5)
(M4 x 16mm)

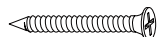

B x (14 + 5)
(M4 x 40mm)

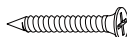

C x (16 + 5)
(M4 x 35mm)

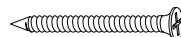

D x (16 + 5)
(M4 x 45mm)



E x (26 + 5)
(M4 x 30mm)



F x (36 + 5)
(8 x 30mm)



G x (8 + 1)
(M8 x 35mm)



H x (4 + 2)

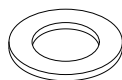

J x (8 + 2)



K x (8 + 5)
(10 x 40mm)

Parts/Pièces

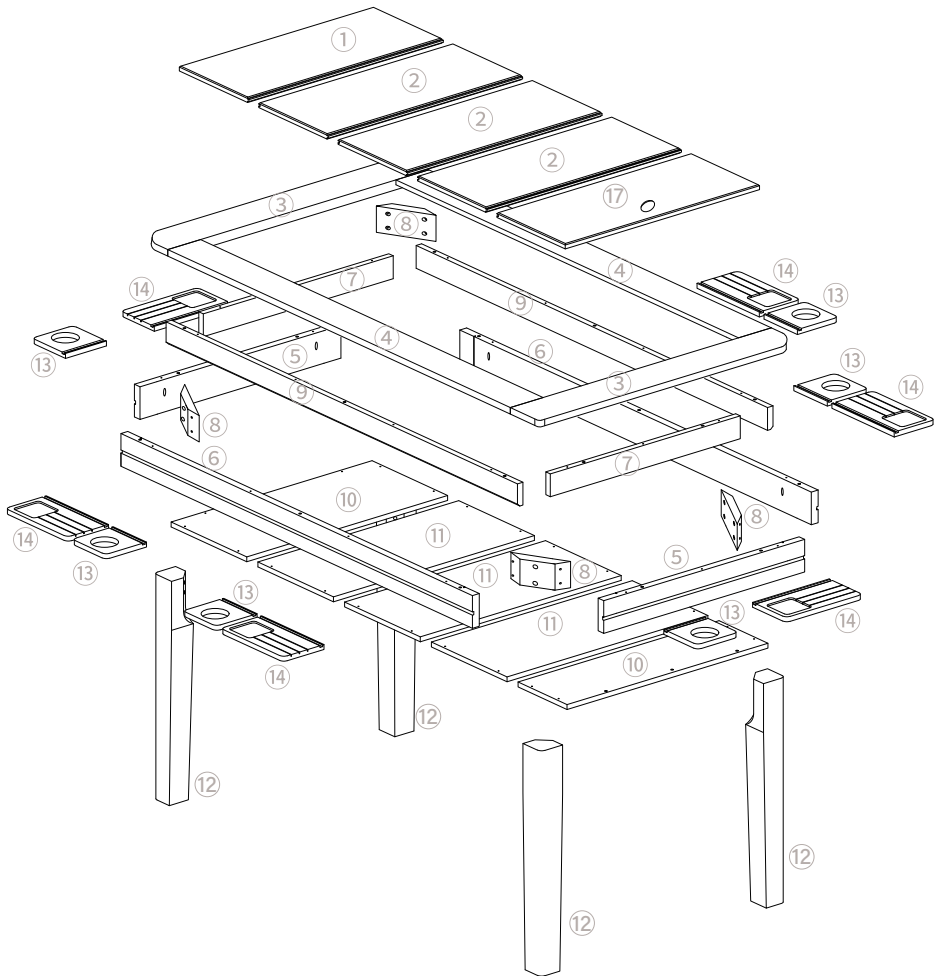

1

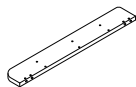

③ (x2)



④ (x2)

 M4 x 16mm A (x16)

10 x 40mm K (x8)

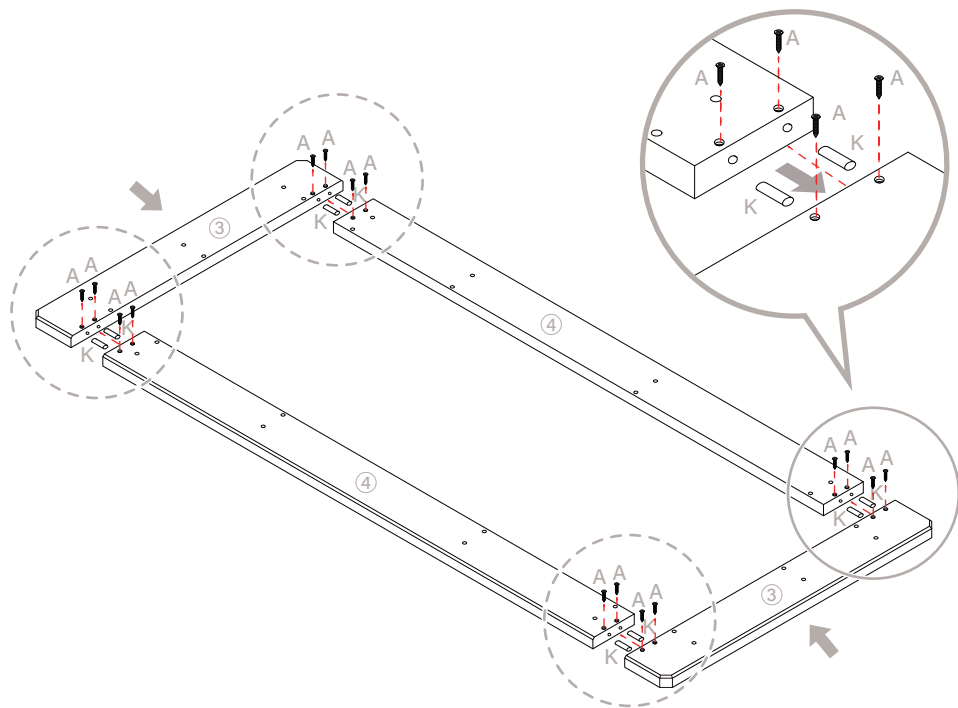

2

 8 x 30mm F (x14)

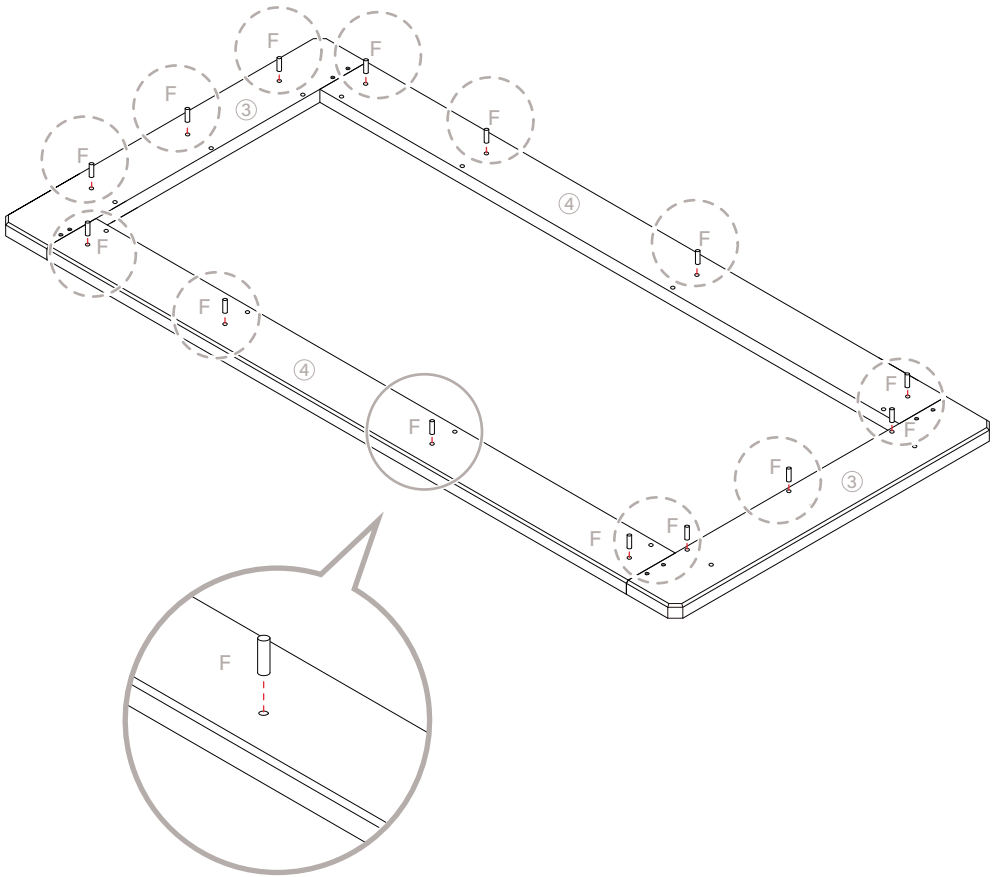

3



⑥ (x2)



⑤ (x2)

M4 x 40mm B (x14)

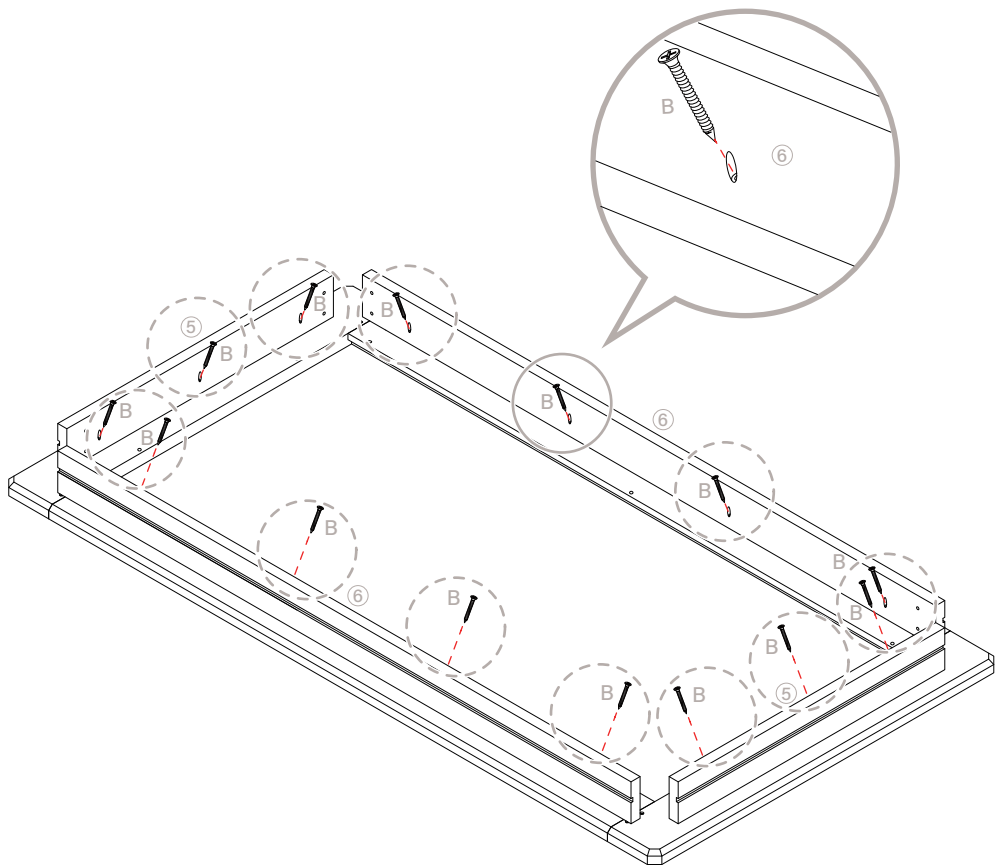

4



⑧ (x4)

← M4 x 35mm C (x16)

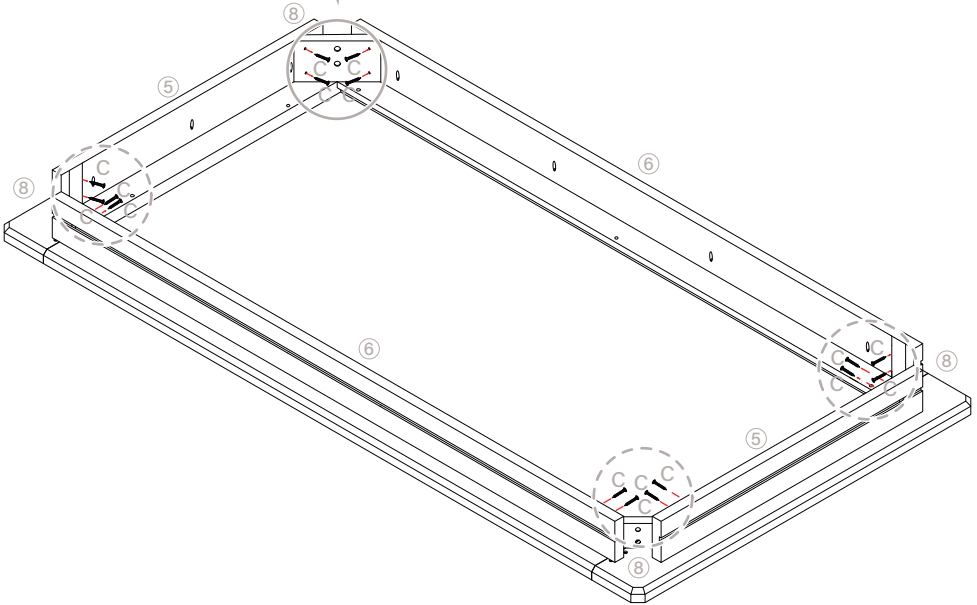
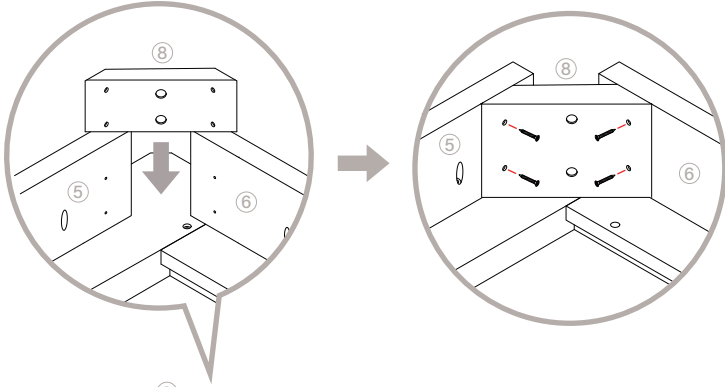

5

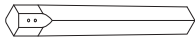

12 (x4)



H (x4)



J (x8)



M8 x 35mm G (x8)

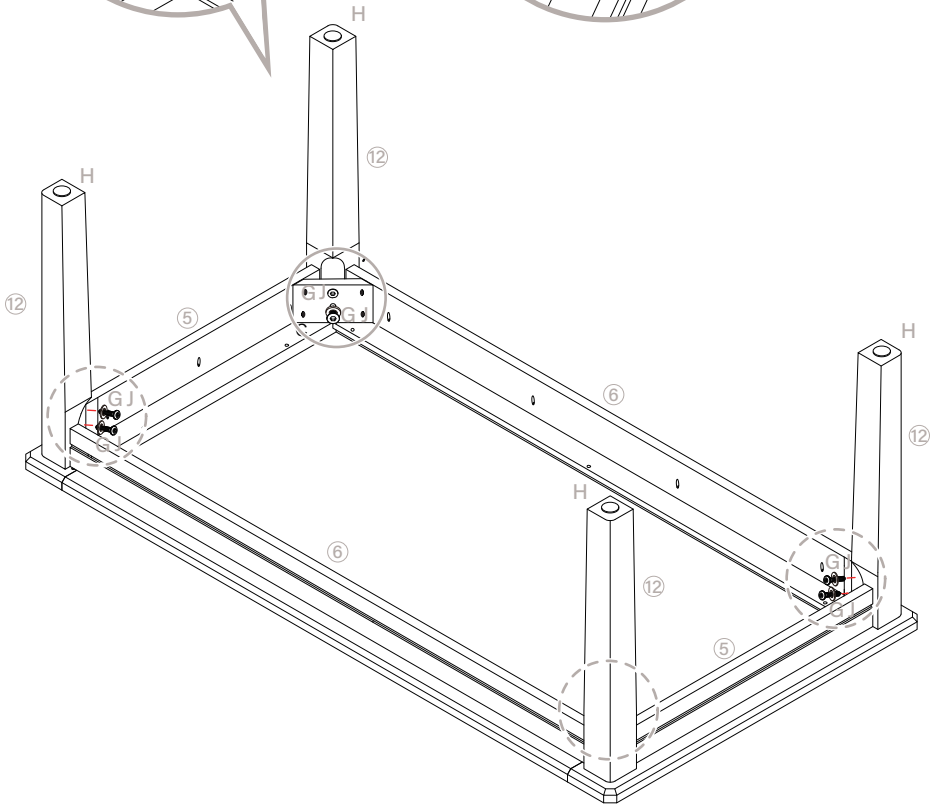
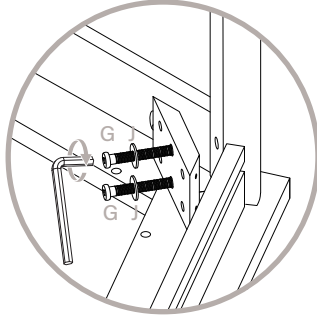
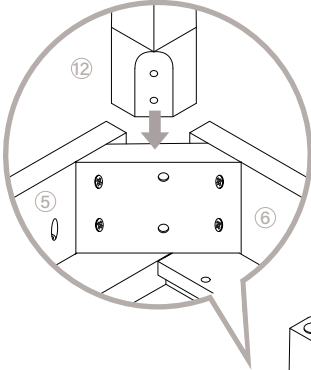

6

 8 x 30mm F (x12)

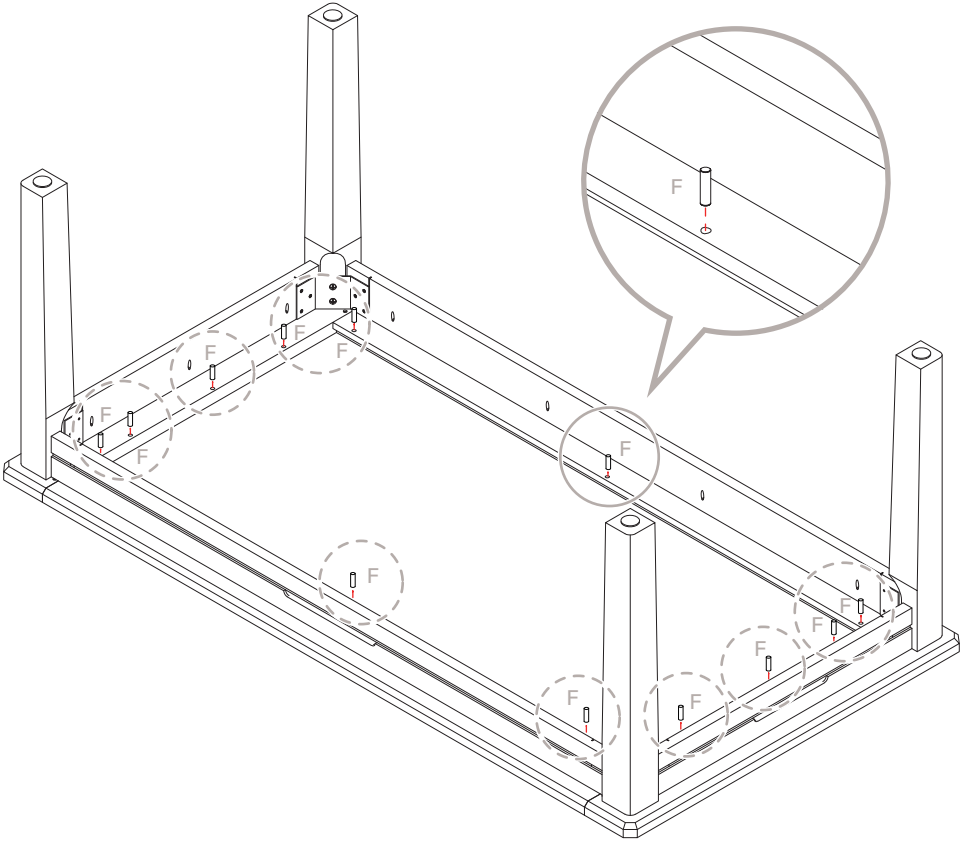

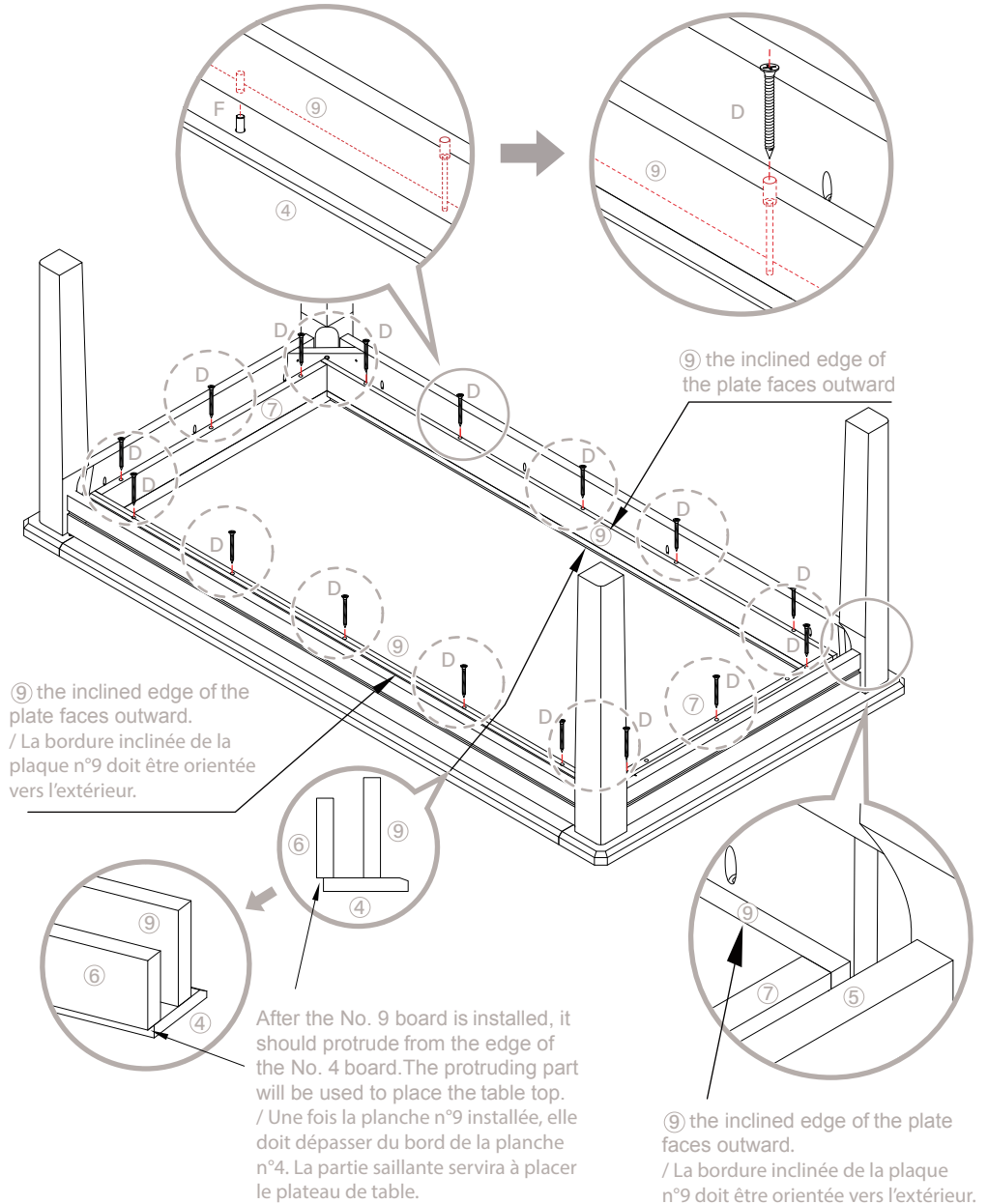
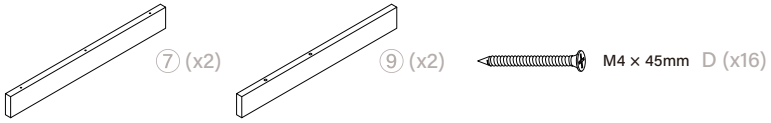

8

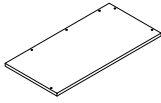

⑩ (x2)

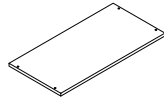

⑪ (x3)

← M4 x 30mm E (x16)

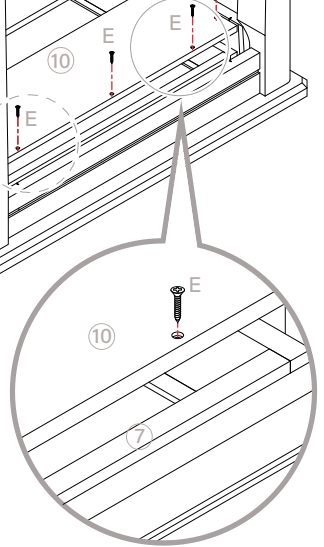
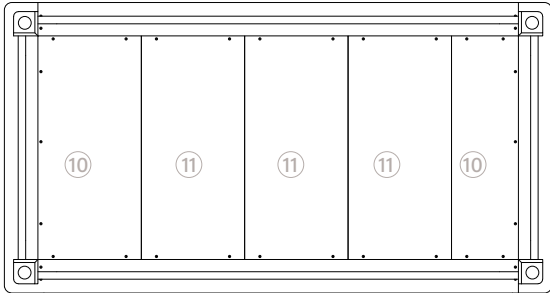
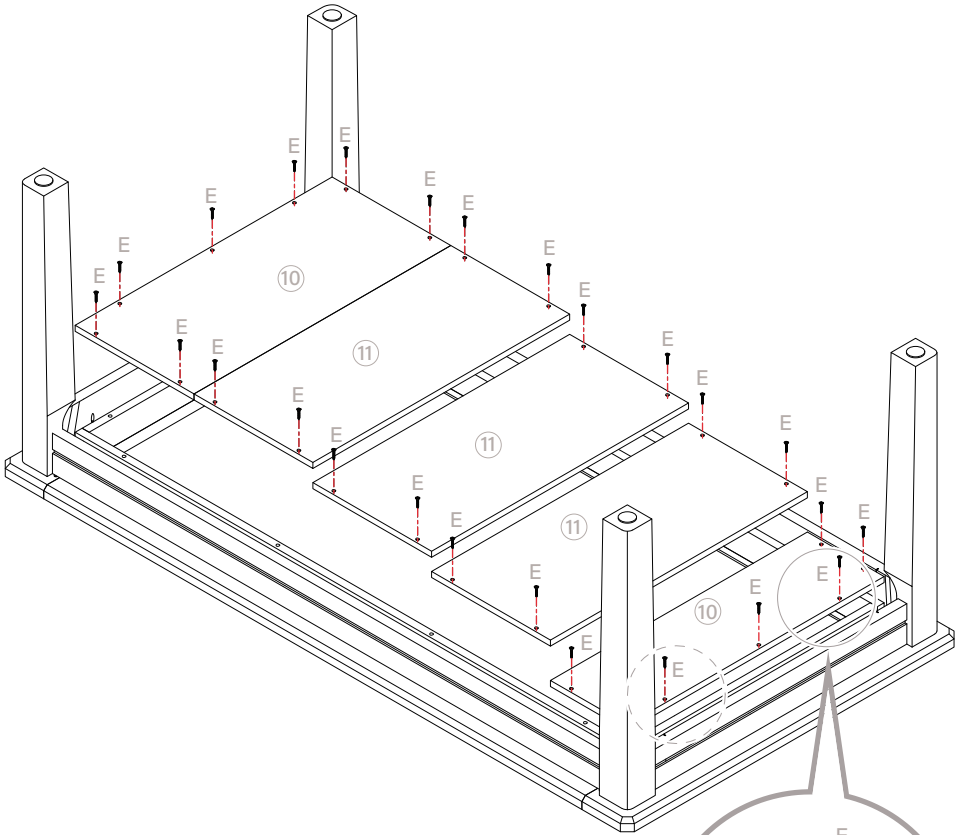

9



16

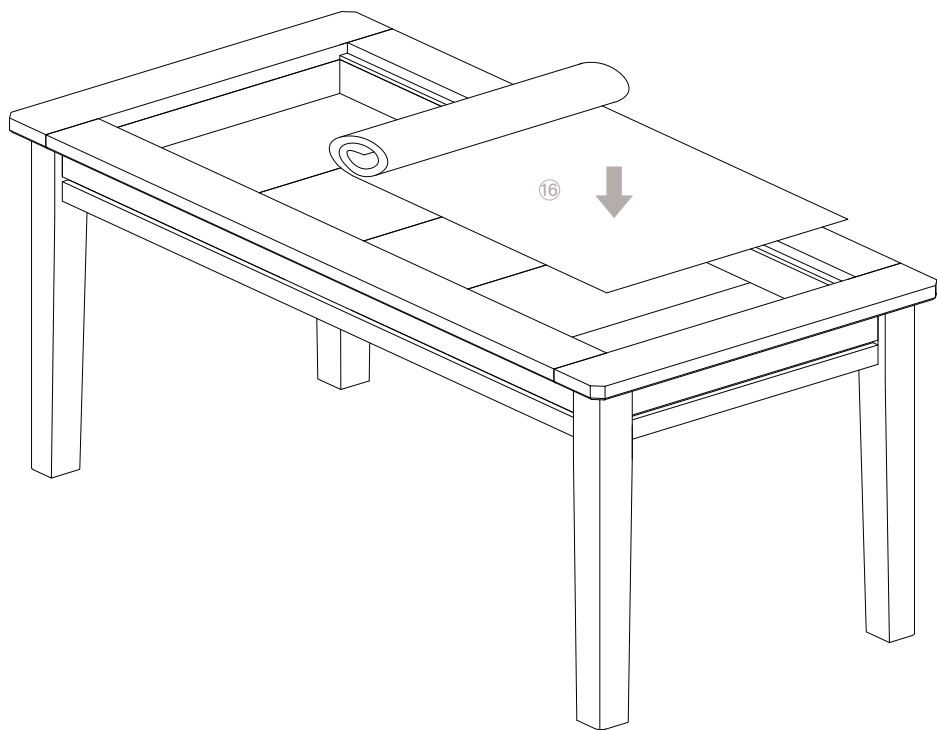

10

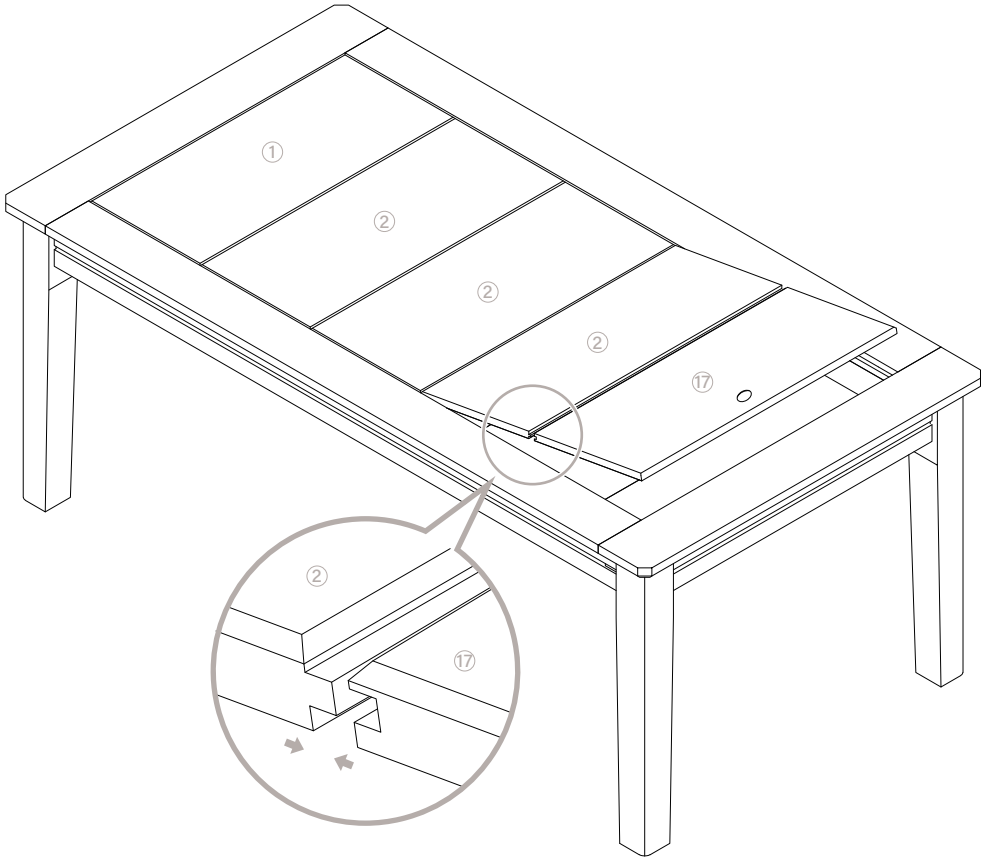

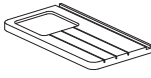

⑭ (x6)

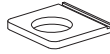

⑬ (x6)



⑮ (x6)

