

# **ASSEMBLY INSTRUCTIONS**

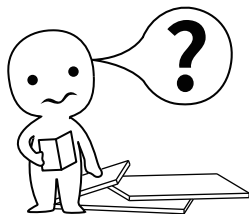

## IMPORTANT INFORMATION!

Please read the entire manual before starting to assembling or using this product. Follow the manual thoroughly and keep it for further reference.

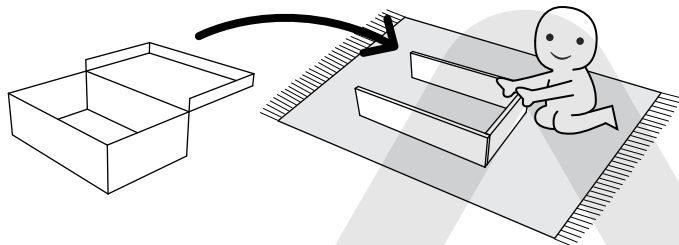

## AVOID SCRATCHES!

In order to avoid scratching the furniture should be assembled on a soft layer—could be a rug.

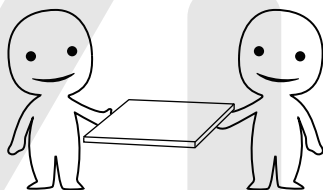

## IMPROVE ASSEMBLY EFFICIENCY !

Try to find a partner to install with you, which can speed up the installation efficiency and shorten the time.

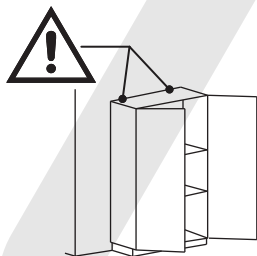

## ANTI-TOPPLE WARNING !

Overturned furniture can cause serious or fatal crush injuries. To prevent tipping, be sure to use a wall-anchoring attachment. If one is not included with this product, please purchase a suitable attachment that fits your wall. If unsure, seek professional advice. Please read and follow all instructions carefully.

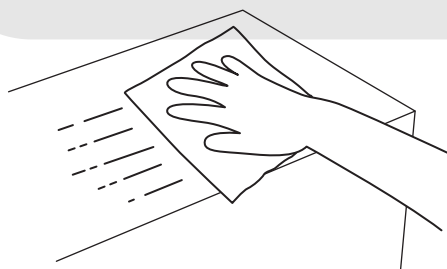

## MAINTENANCE AND CLEANING !

For regular maintenance and cleaning, use a rag dipped in neutral detergent to wipe the frame thoroughly, and then dry it with a clean rag. For glass surfaces, wipe with a rag dampened with water or glass cleaner, and then dry with a clean, dry cloth.

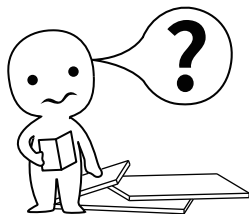

## ¡INFORMACIÓN IMPORTANTE!

Por favor, lee todo el manual antes de comenzar a ensamblar o usar este producto. Sigue las instrucciones detenidamente y consérvalo para futuras consultas.

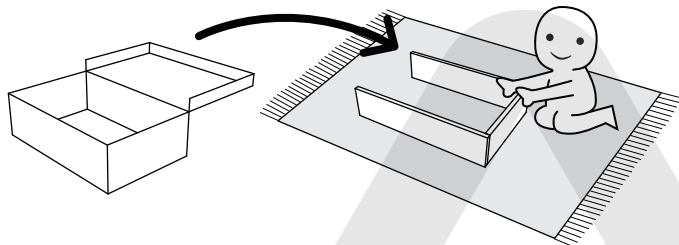

## ¡EVITA LOS RAYONES!

Para evitar que el mueble se raye, debe ensamblarse sobre una superficie suave, como una alfombra.

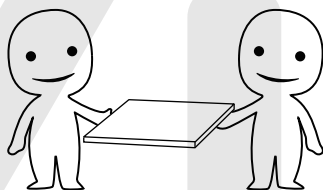

## ¡MEJORA LA EFICIENCIA!

Intenta encontrar a alguien que te ayude con la instalación; trabajar en pareja puede aumentar la eficiencia y reducir el tiempo de montaje.

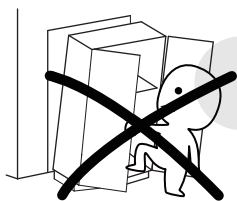
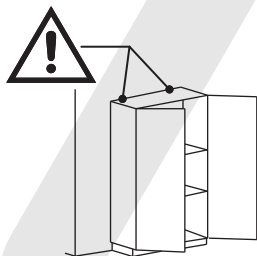

## ¡ADVERTENCIA ANTIVUELCO!

El mobiliario volcado puede causar lesiones graves o incluso mortales por aplastamiento. Para evitar que se vuelque, asegúrate de utilizar el sistema de anclaje a la pared. Si este producto no lo incluye, adquiere un anclaje compatible con tu pared. Si no estás seguro de cuál usar, busca asesoramiento profesional. Lee y sigue cuidadosamente cada paso de las instrucciones.

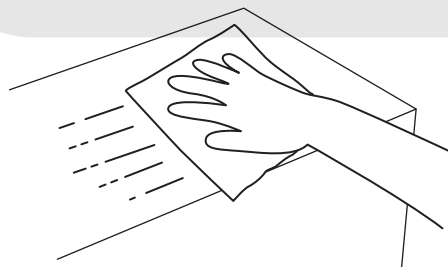

## ¡MANTENIMIENTO Y LIMPIEZA!

Para el mantenimiento y la limpieza regulares del producto, limpia el marco con un paño humedecido en un detergente neutro y luego sécalo con un paño limpio. Para los materiales de vidrio, límpialos con un paño humedecido en limpiador de vidrios con agua y luego sécalos con un paño seco.



The following are common installation steps. Correct operation is required to avoid product damage.

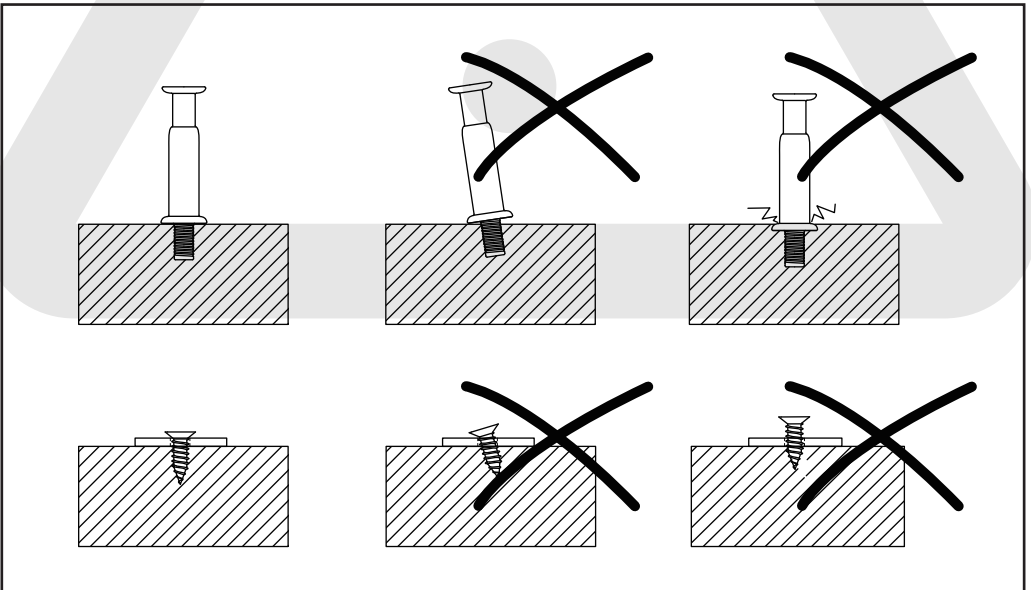
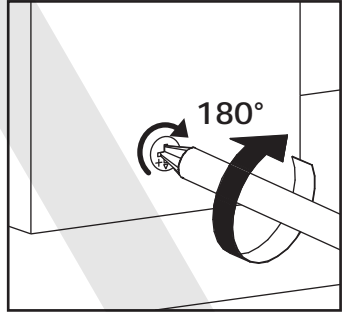
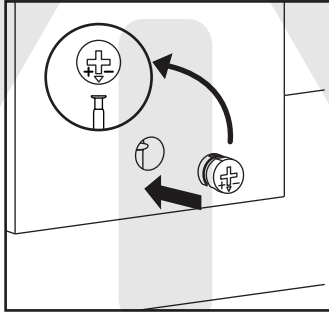
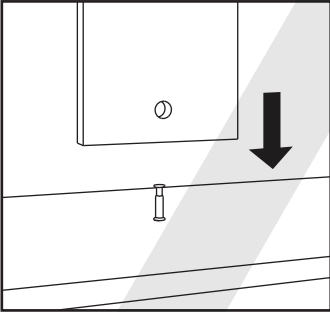
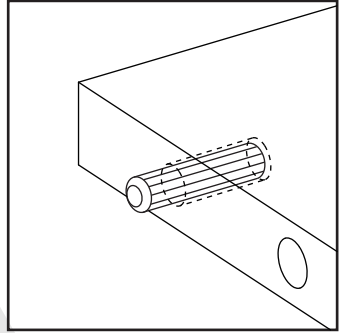
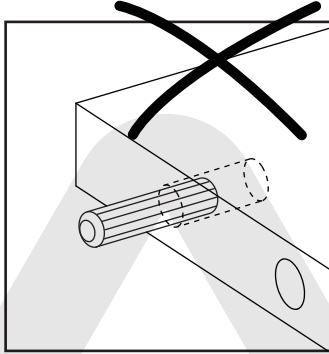
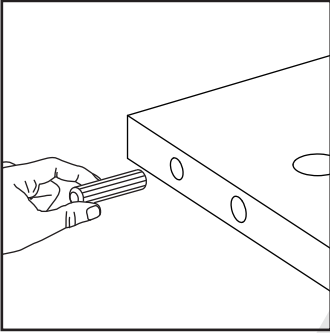



Los siguientes pasos de instalación son bastante comunes y requieren una operación correcta durante el proceso de montaje. El uso incorrecto puede dañar el mueble.

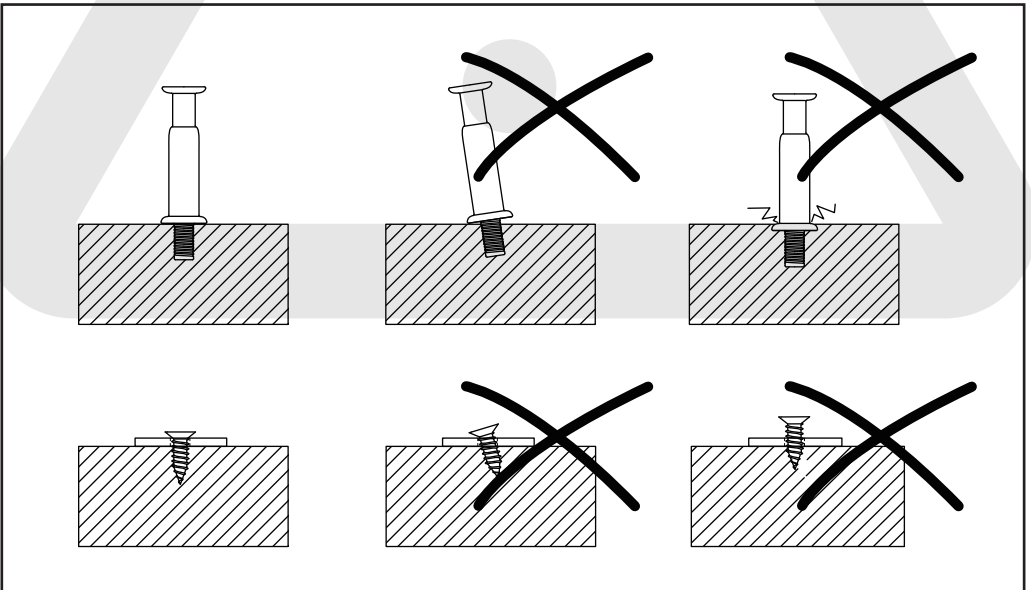
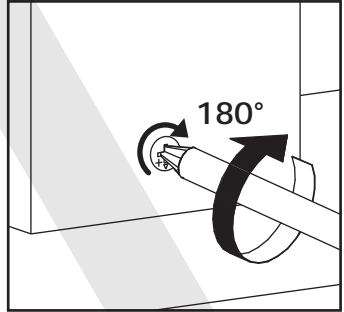
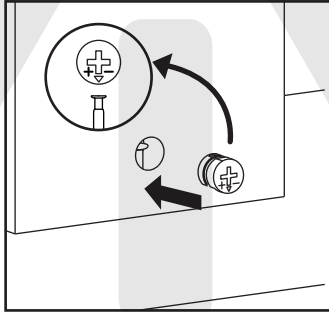
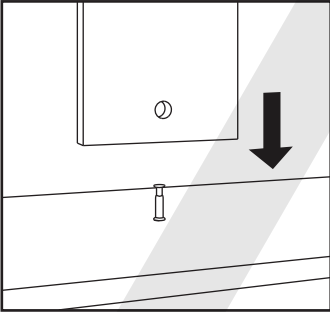
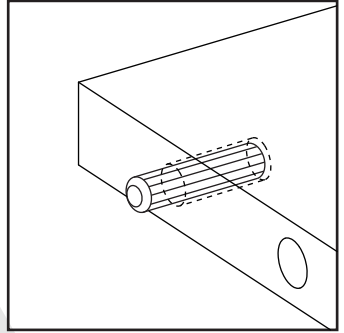
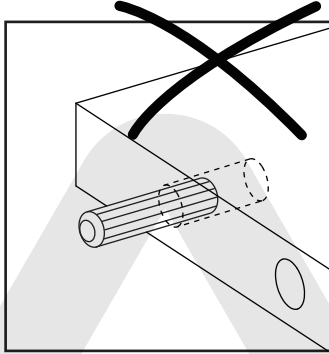
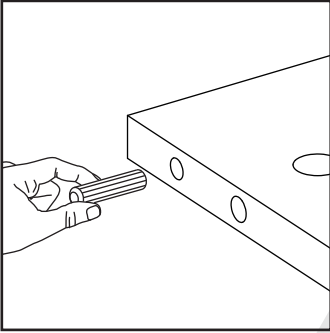



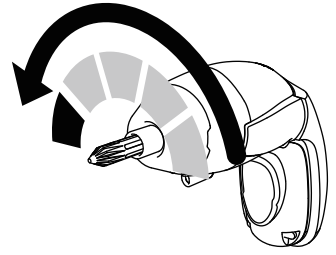
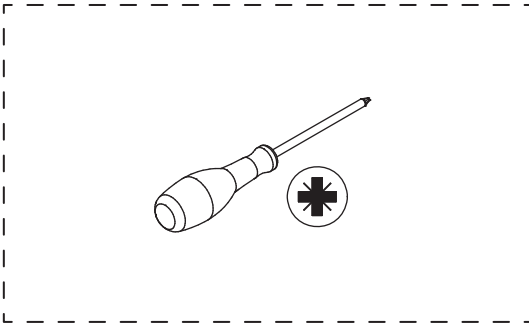







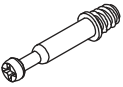

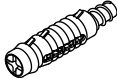
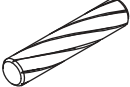
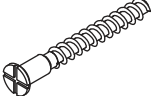

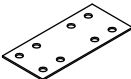
**Please prepare the following tools**

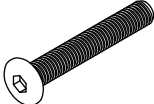

If you choose to use power tools, set them to a low-power setting. Use caution—power tools may crack or damage the furniture and can also harm the hardware.

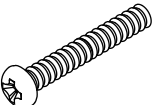

Some accessories have similar shapes, please distinguish them according to their numbers and sizes during installation.

<p>A x 36</p>  <p>CRA0635B</p>	<p>B x 36</p> 	<p>C x 36</p>  <p>CRB1595A</p>	<p>D x 24</p> 	<p>E x 60</p>  <p>CRF0630A</p>
<p>F x 48</p>  <p>CRC0540A</p>	<p>G x 19</p>  <p>CRF0840A</p>	<p>H x 14</p> 	<p>J x 124</p>  <p>CRD3514A</p>	<p>K x 16</p>  <p>CRD3535A</p>
<p>L x 4</p> 	<p>31 x 6</p>  <p>Ø6 x 8 mm</p>	<p>32 x 16</p>  <p>Ø6 x 40 mm</p>	<p>33 x 4</p>  <p>Ø6 x 8 mm</p>	<p>34 x 8</p>  <p>Ø6 x 12 mm</p>
<p>35 x 4</p>  <p>Ø6 x 20 mm</p>	<p>36 x 2</p>  <p>Ø4 x 45 mm</p>	<p>38 x 1</p> 	<p>39 x 1</p>  <p>#4</p>	



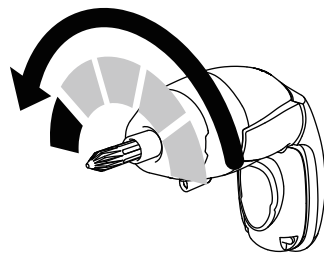
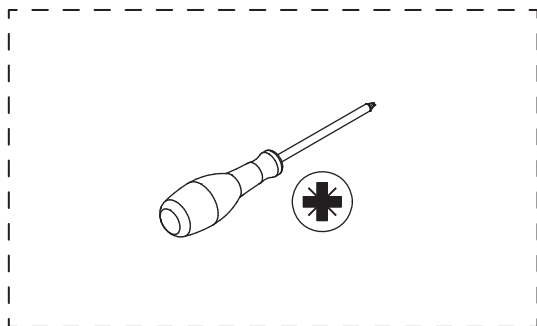







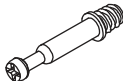



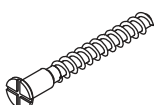

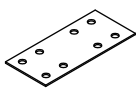
## Por favor, prepara las siguientes herramientas

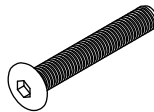

Si decides utilizar herramientas eléctricas, ajústalas a una velocidad baja. ¡Ten cuidado! Las herramientas eléctricas pueden causar grietas o daños en el mueble, y también pueden dañar los herrajes.

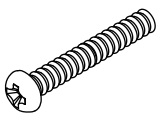

Algunos accesorios tienen la misma forma; por favor, distíngalos según sus números y tamaños durante la instalación.

<p>A x 36</p>  <p>CRA0635B</p>	<p>B x 36</p> 	<p>C x 36</p>  <p>CRB1595A</p>	<p>D x 24</p> 	<p>E x 60</p>  <p>CRF0630A</p>
<p>F x 48</p>  <p>CRC0540A</p>	<p>G x 19</p>  <p>CRF0840A</p>	<p>H x 14</p> 	<p>J x 124</p>  <p>CRD3514A</p>	<p>K x 16</p>  <p>CRD3535A</p>
<p>L x 4</p> 	<p>31 x 6</p>  <p>Ø6 x 8 mm</p>	<p>32 x 16</p>  <p>Ø6 x 40 mm</p>	<p>33 x 4</p>  <p>Ø6 x 8 mm</p>	<p>34 x 8</p>  <p>Ø6 x 12 mm</p>
<p>35 x 4</p>  <p>Ø6 x 20 mm</p>	<p>36 x 2</p>  <p>Ø4 x 45 mm</p>	<p>38 x 1</p> 	<p>39 x 1</p>  <p>#4</p>	

# Parts List

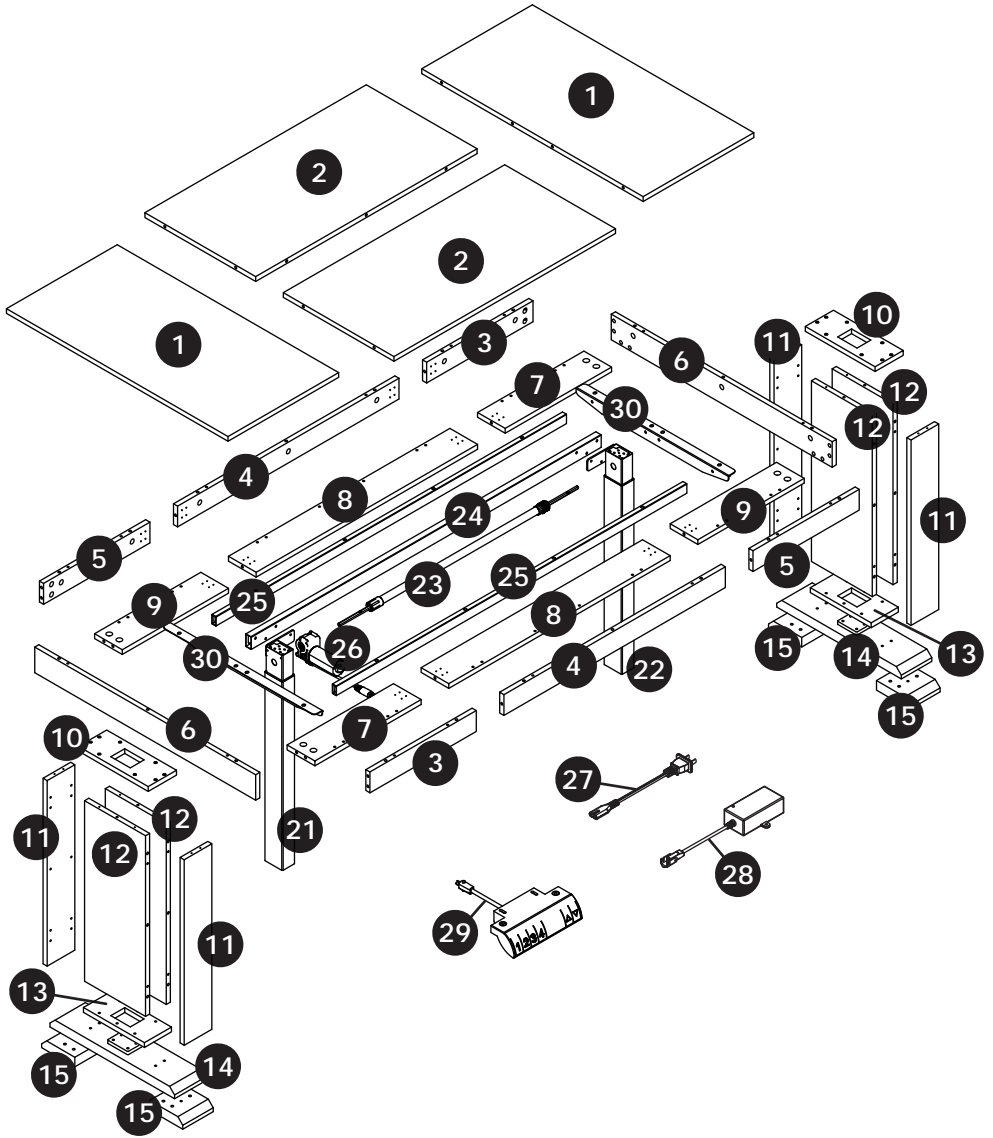

**⚠ WARNING**

Children have died from furniture tipover. To reduce the risk of furniture tipover:

- ALWAYS install Anti-tip device provided
- NEVER put a TV on this product.
- NEVER allow children to stand, climb or hang on drawers, doors, or shelves.
- NEVER open more than one drawer at a time.
- Place heaviest items in the lowest drawers.

This is a permanent label. Do not remove!



90 MINUTES



2 ADULTS



DIFFICULT

# Lista de Piezas

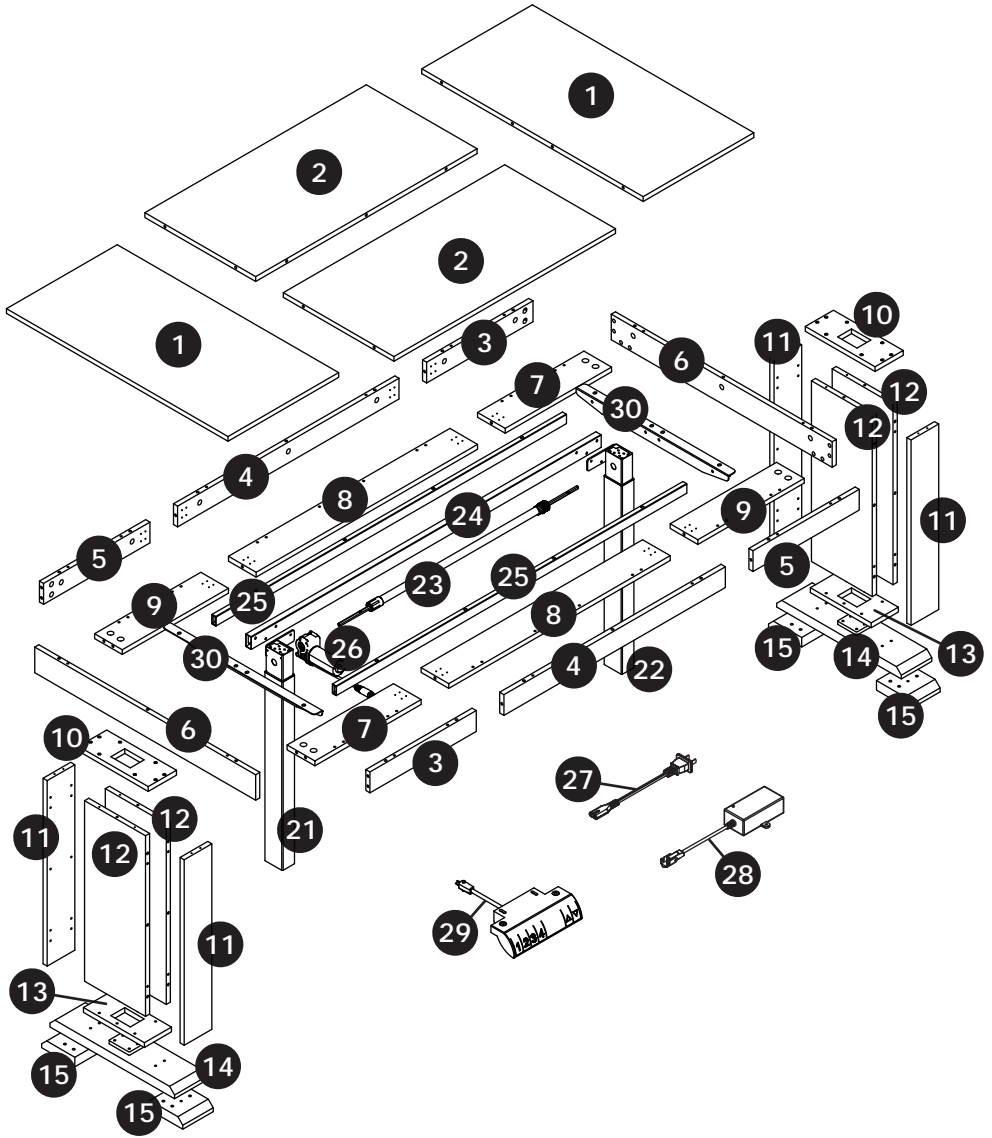

**⚠ ADVERTENCIA**

Los niños han muerto por el vuelco de muebles. Para reducir el riesgo de que el mueble se vuelque:

- SIEMPRE instala el dispositivo antivuelco incluido.
- NUNCA coloques un televisor sobre este producto.
- NUNCA permitas que los niños se suban, trepen o cuelguen de los cajones, puertas o estantes.
- NUNCA abras más de un cajón a la vez.
- Coloca los objetos más pesados en los cajones inferiores.

Esta es una etiqueta permanente.  
¡No la retires!



90 MINUTOS



2 ADULTOS



DIFÍCIL

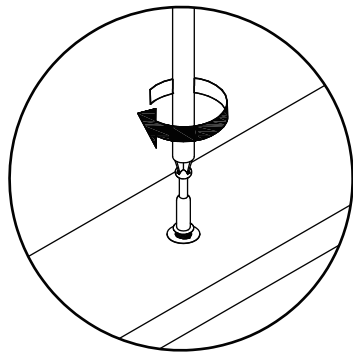
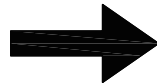
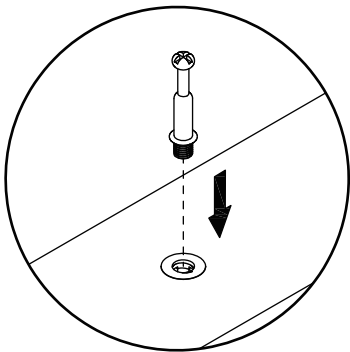
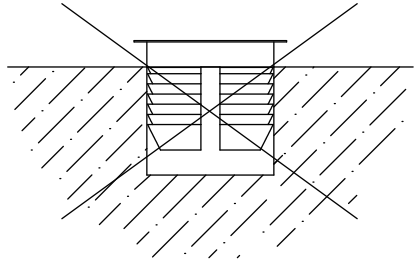
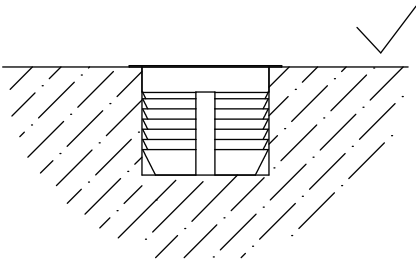
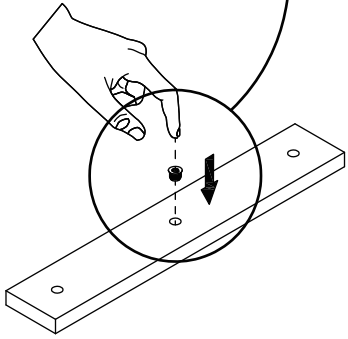
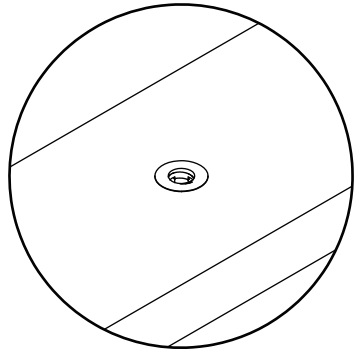
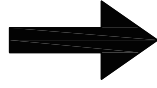
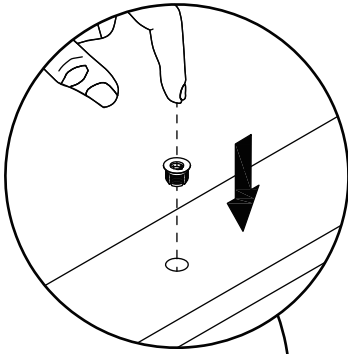

# 01



[EN] Connect Panel 13 to the two Panel 12s using wooden dowels (E), then secure them with screws (F).

[ES] Conecte el panel 13 a los dos paneles 12 utilizando espigas de madera (E) y luego fíjelos con tornillos (F).

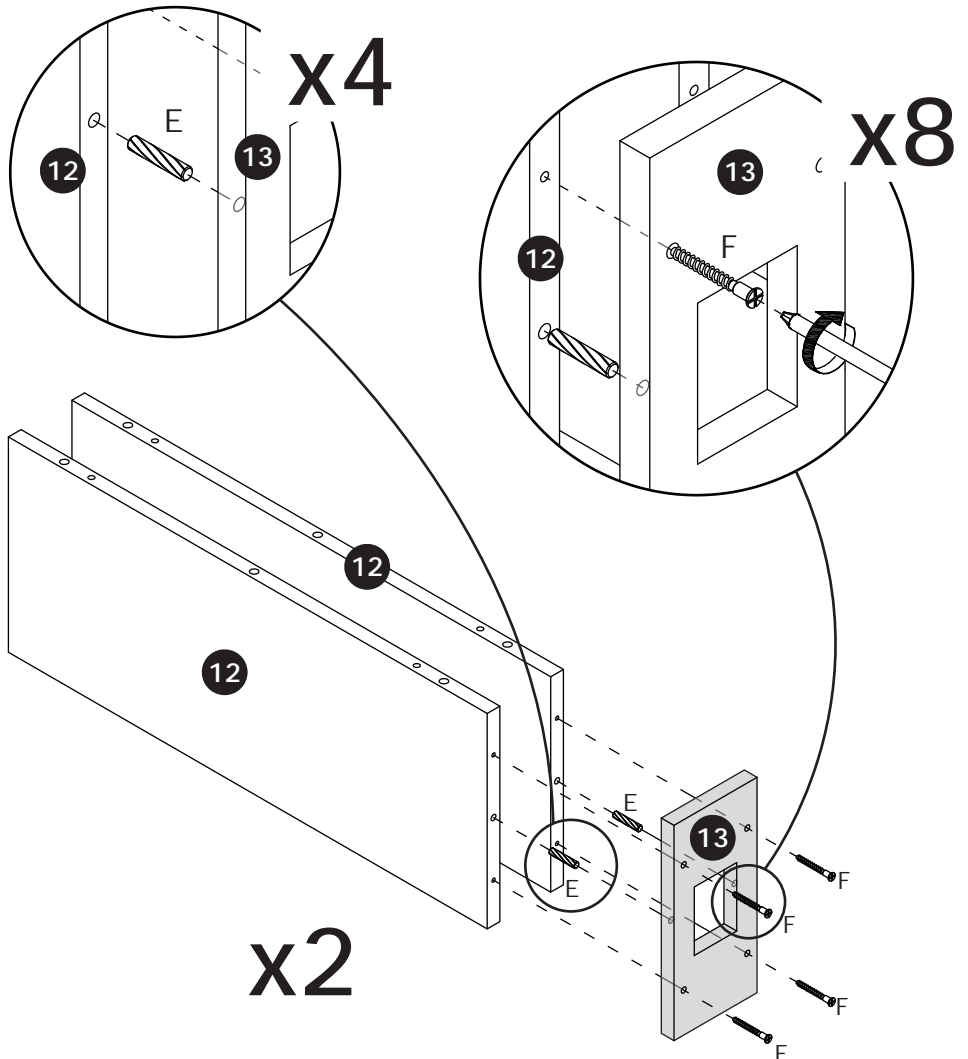

# 02



[EN] Screw Part (D) into Panel 11.

[ES] Atornille la pieza (D) en el panel 11.

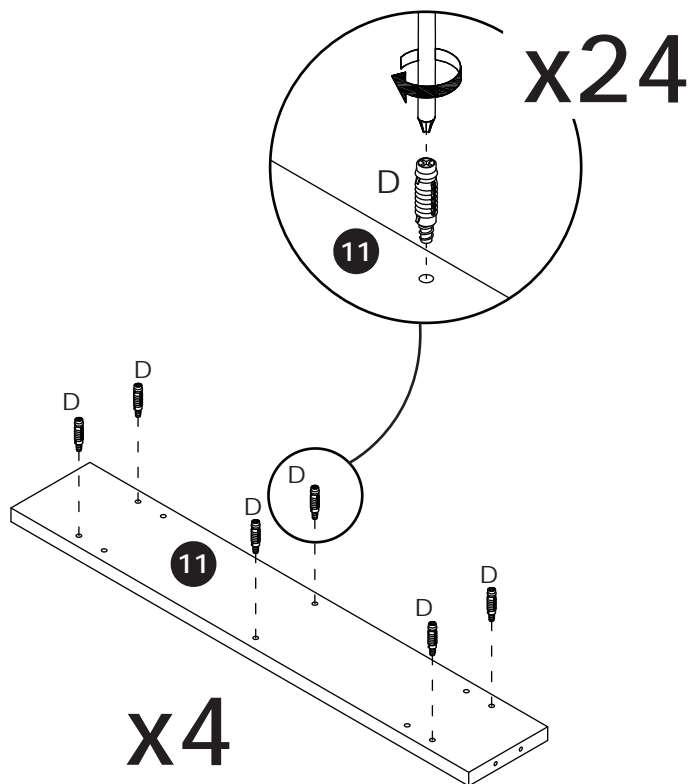

# 03



[EN] Connect Panel 11 to Panel 12 with wooden dowels (E).

[ES] Conecte el panel 11 al panel 12 con espigas de madera (E).

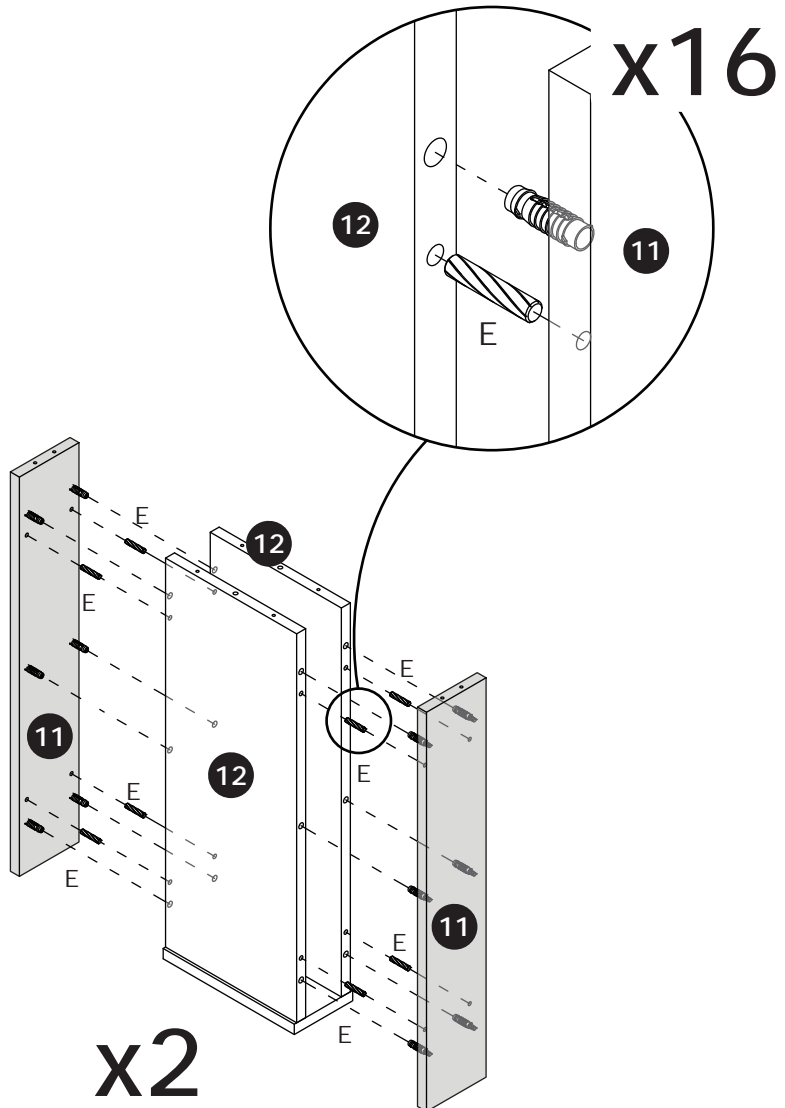



# 05



[EN] Connect Panel 15 to Panel 14 with wooden dowels (E), then secure both panels with screws (K).

[ES] Conecte el panel 15 al panel 14 con espigas de madera (E) y luego fije ambos paneles con tornillos (K).

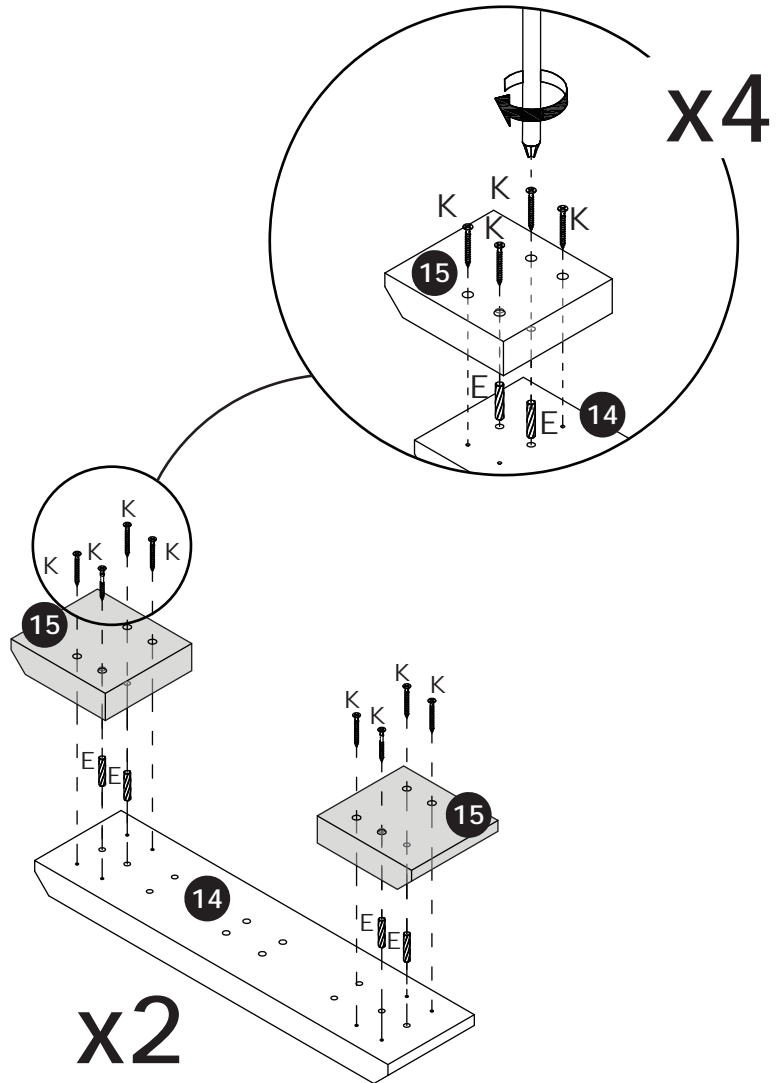

# 06



[EN] Secure Panel 14 to Panel 11 using screws (F).

[ES] Fije el panel 14 al panel 11 con tornillos (F).

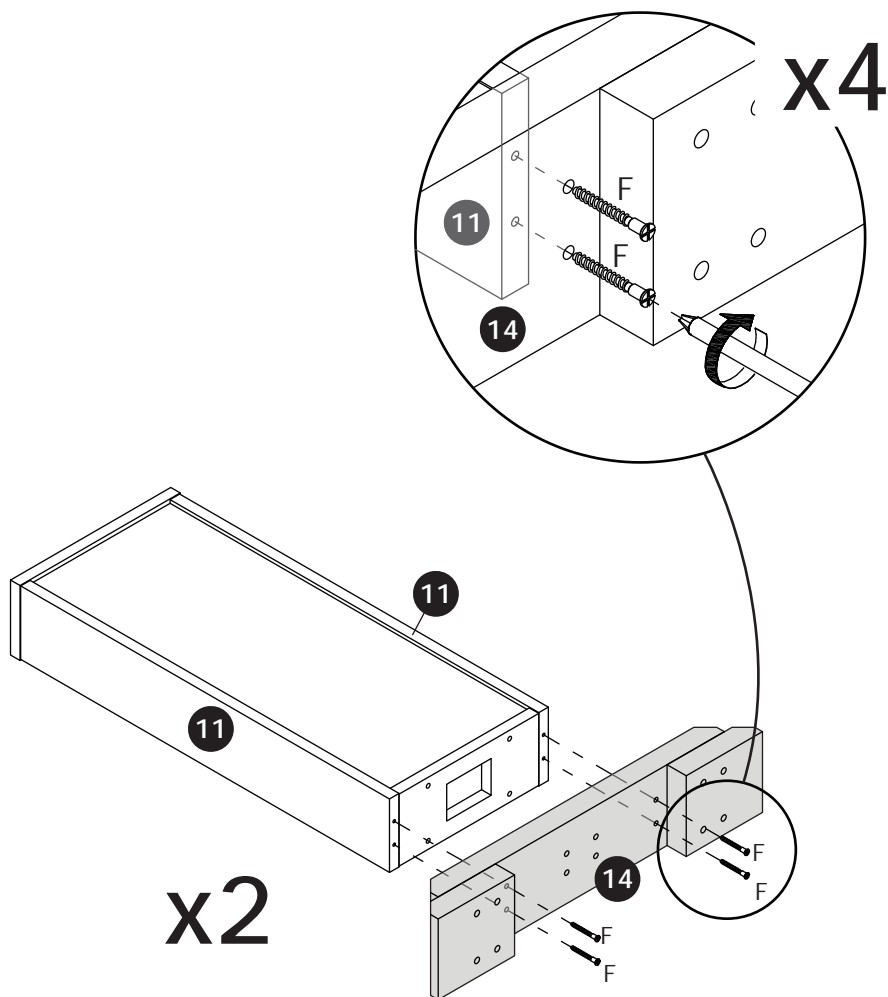

# 07

[EN] Insert Steel Frames 21 and 22 into the mounting unit, then lay the assembly down.

[ES] Inserte los marcos de acero 21 y 22 en la unidad de montaje y luego coloque el conjunto.

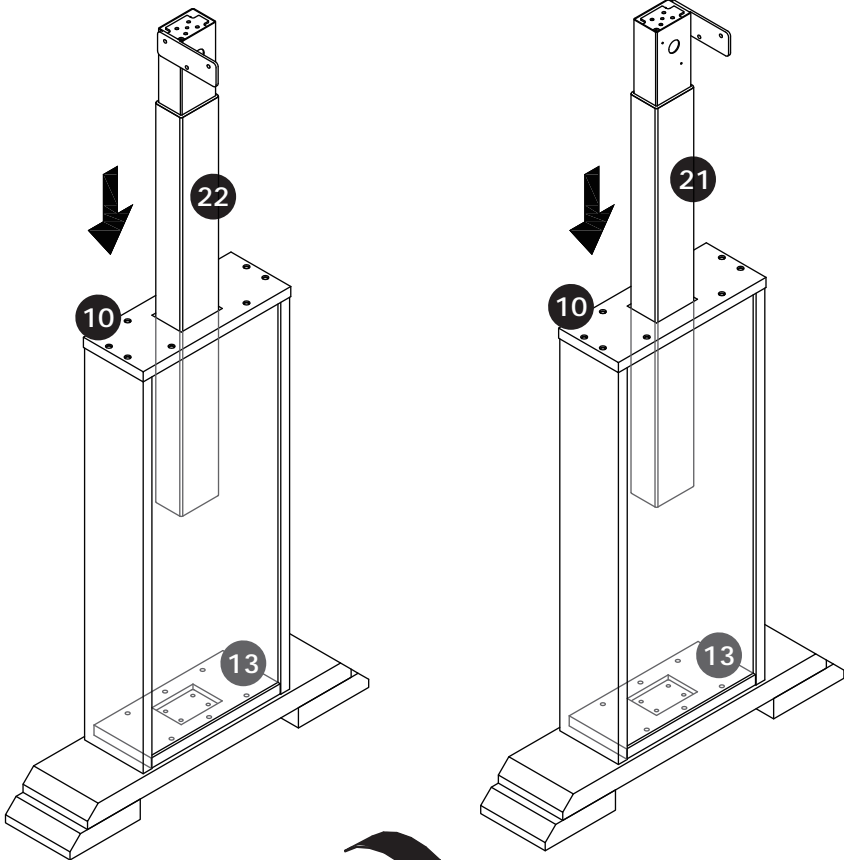

Turn over  
Dé la vuelta.

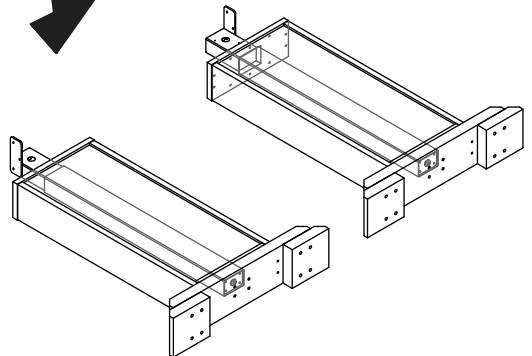

# 08



[EN] Secure Steel Frame 21 to Panel 14 with screws (32).  
Secure Steel Frame 22 to Panel 14 with screws (32).

[ES] Fije el marco de acero 21 al panel 14 con tornillos (32).  
Fije el marco de acero 22 al panel 14 con tornillos (32).

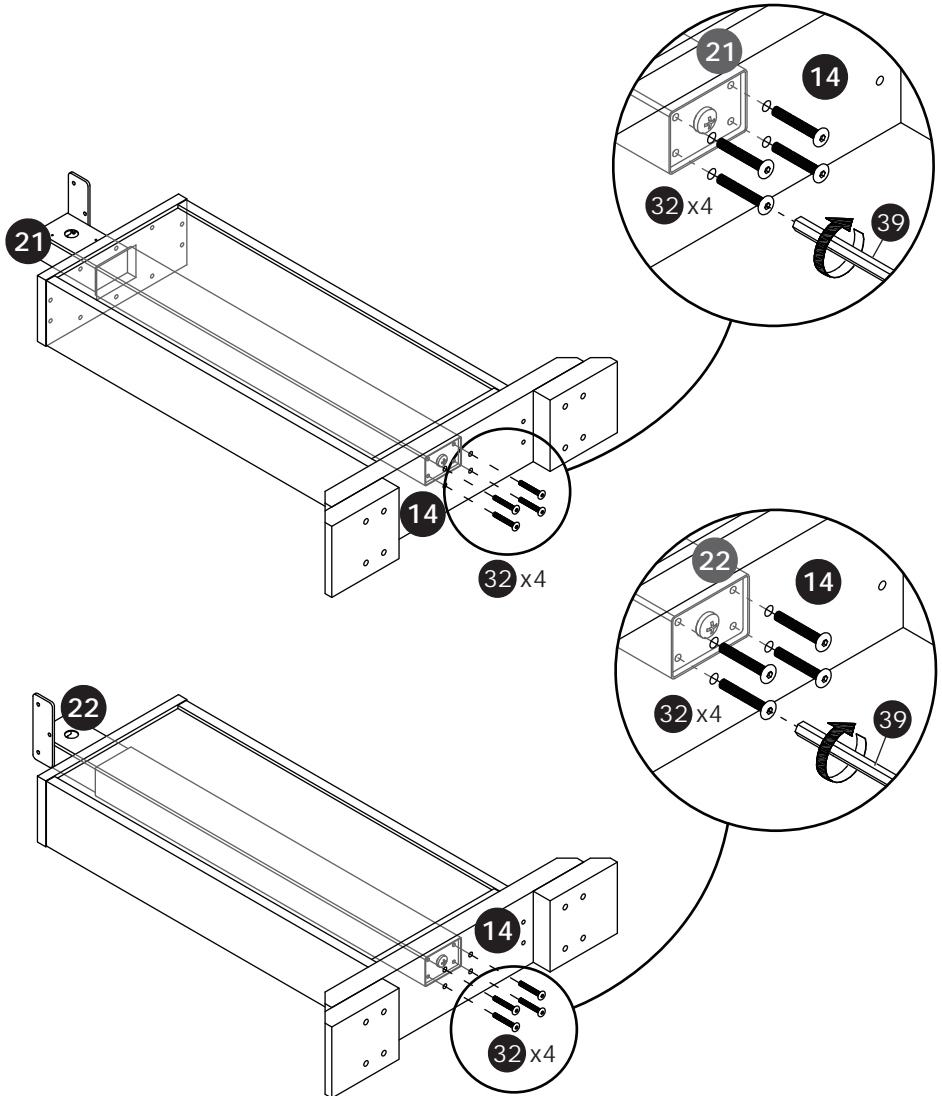

# 09



[EN] Secure Steel Frame 24 to Steel Frames 21 and 22 using screws (31).

[ES] Fije el marco de acero 24 a los marcos de acero 21 y 22 con tornillos (31).

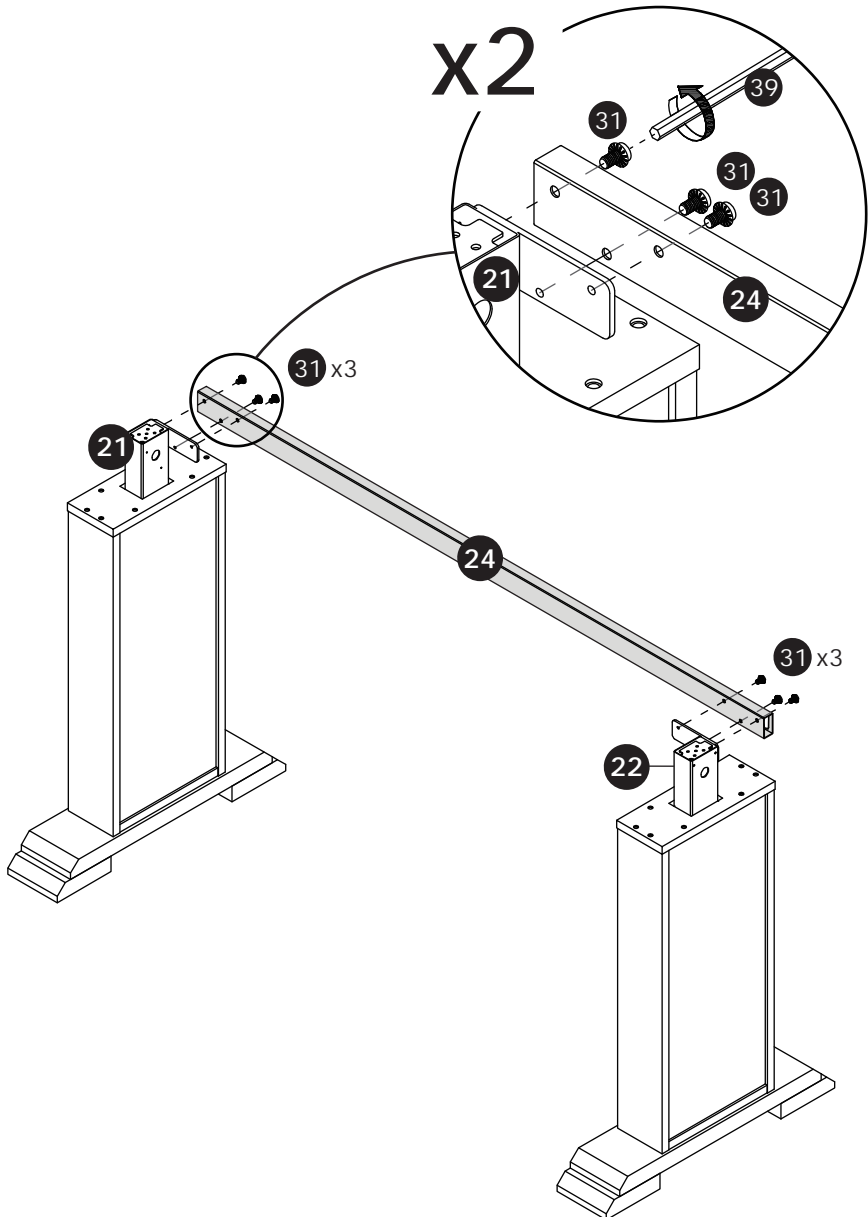

# 10

[EN] Press Steel Frames 21 and 22 down to the lowest position.

[ES] Presione los marcos de acero 21 y 22 hasta la posición más baja.

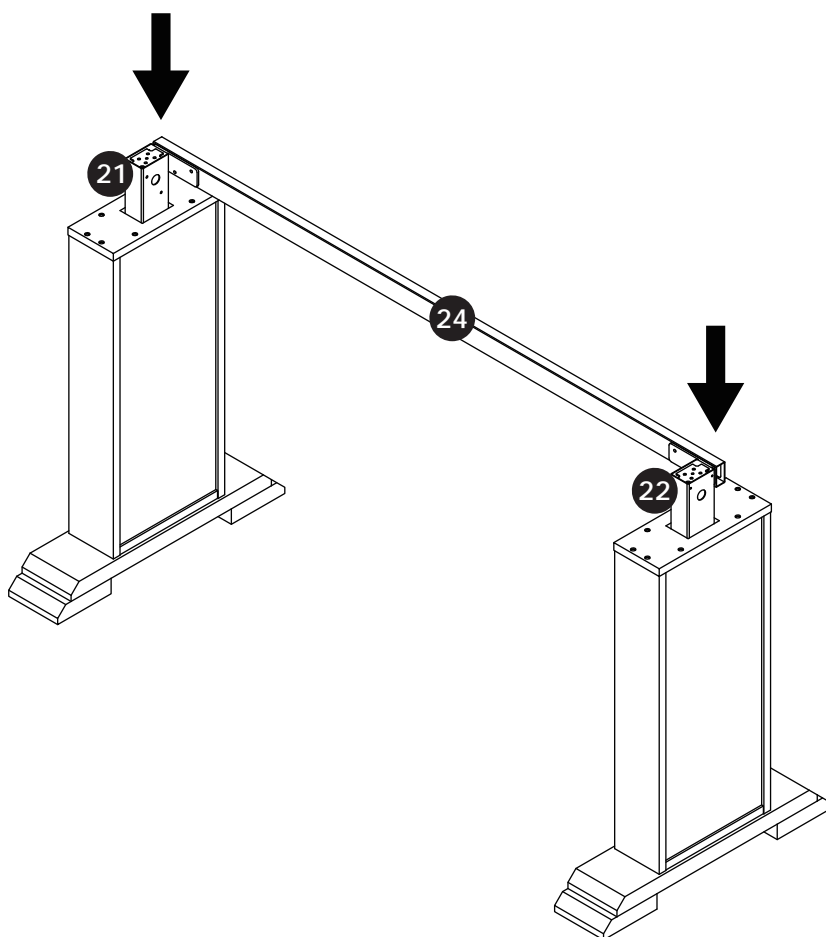

# 11

[EN] Install Part (26-2) onto Motor (26-1).

[ES] Instale la pieza (26-2) sobre el motor (26-1).

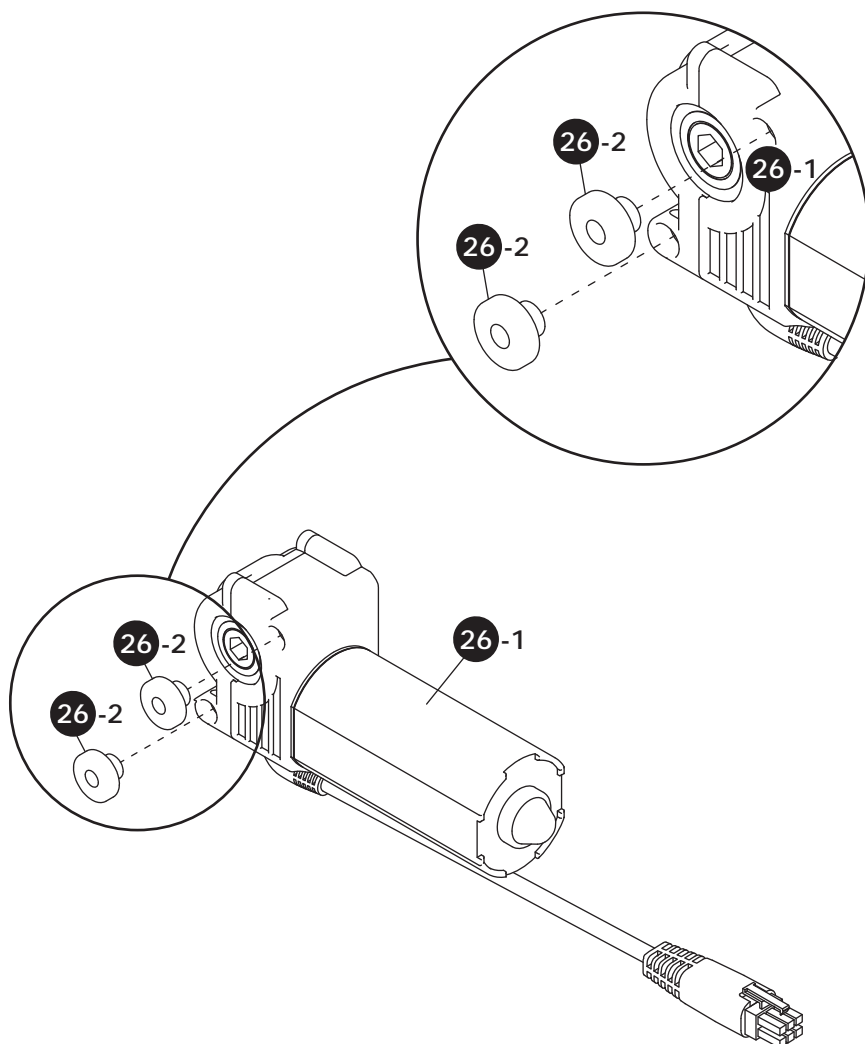



# 13

[EN] Loosen Part (23-1) and extend it to insert into Steel Frame 22.

[ES] Afloje la pieza (23-1) y extiéndala para insertarla en el marco de acero 22.

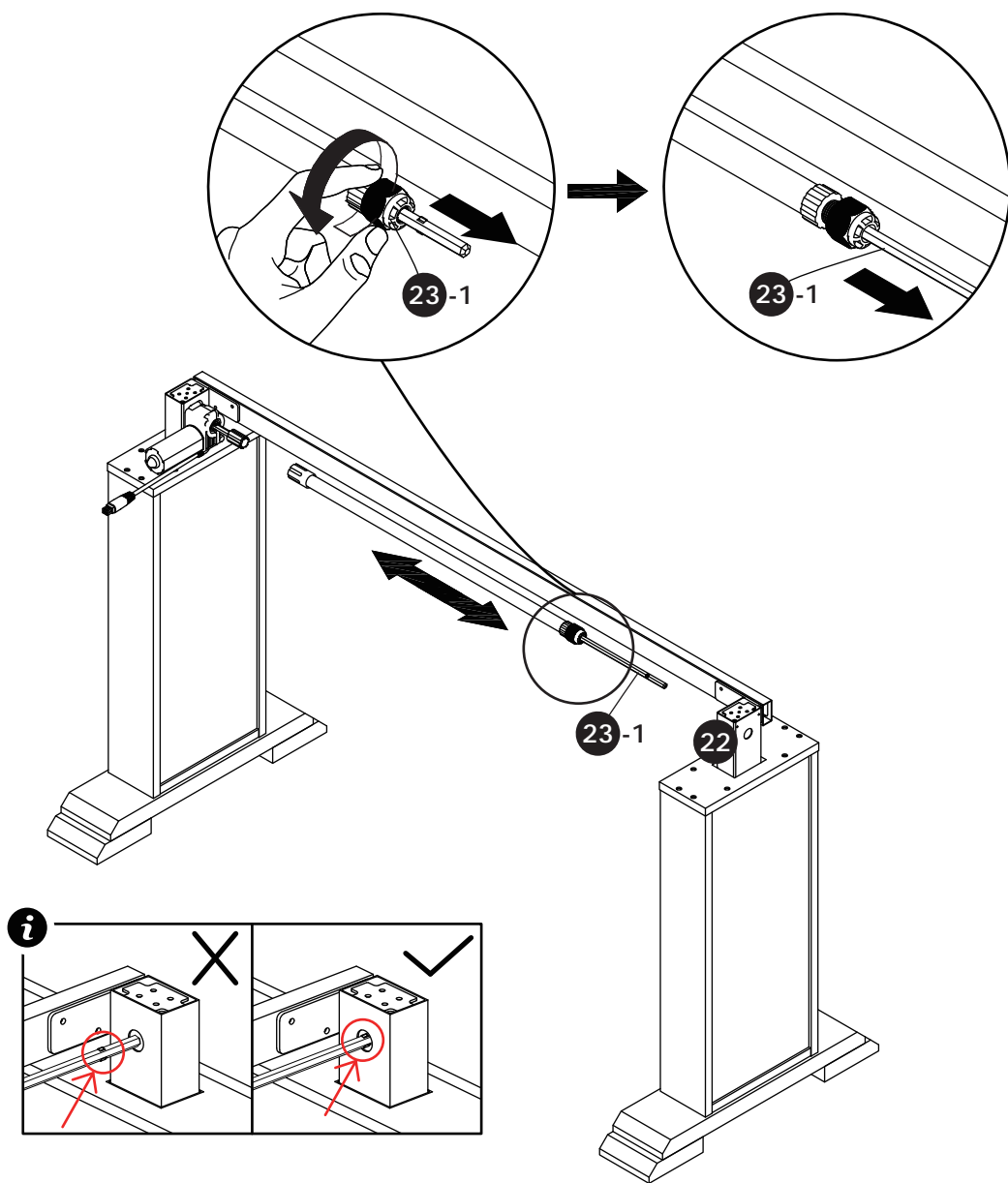

# 14

[EN] Connect Part (23-1) to Part (23-2), then tighten its knob.

[ES] Conecte la pieza (23-1) con la pieza (23-2) y luego apriete la perilla de la pieza (23-1).

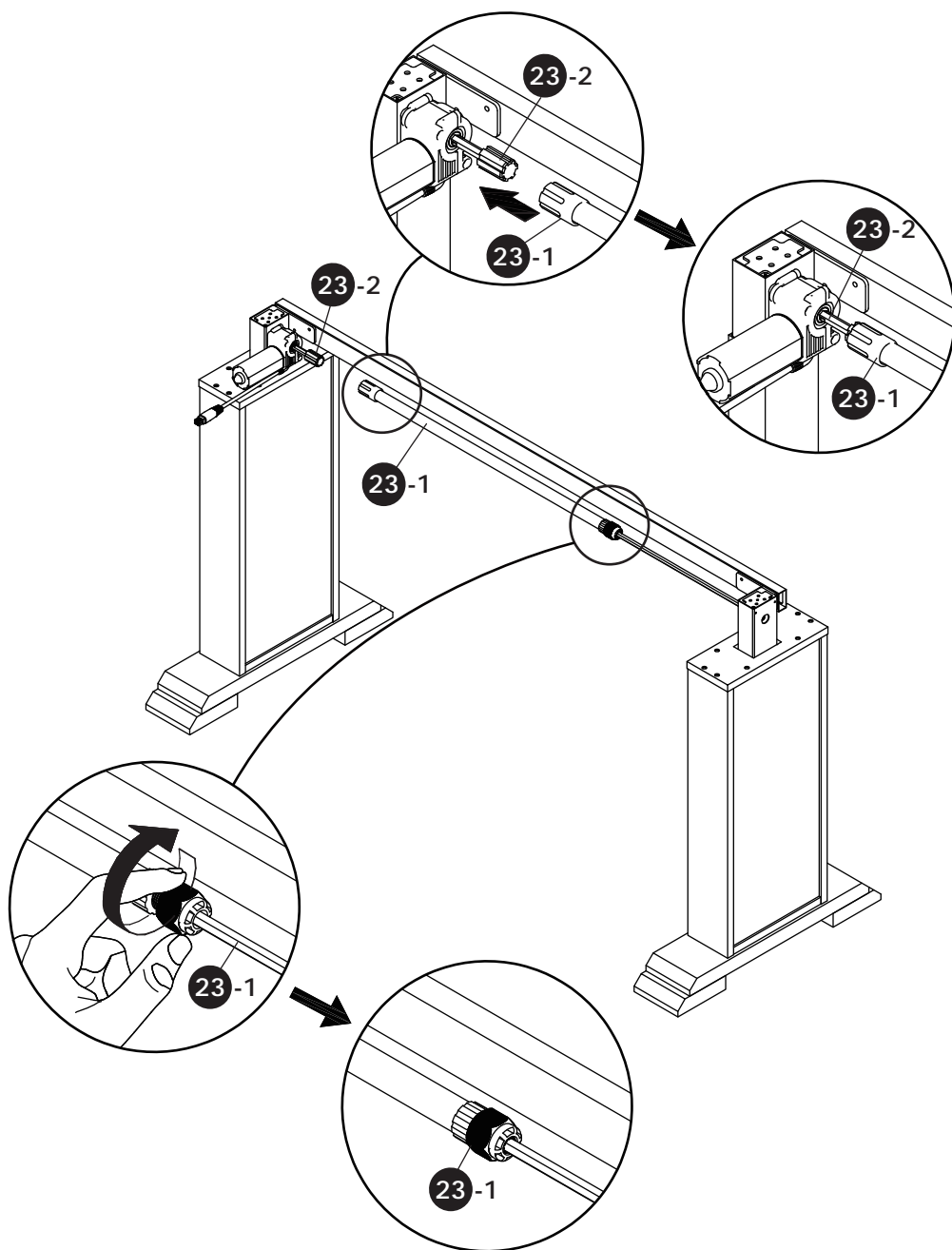

# 15

[EN] As shown in the figure, connect Motor (26) with Parts (29), (28), and (27), then connect the assembly to the power supply.

[ES] Como se muestra en la figura, conecte el motor (26) con las piezas (29), (28) y (27), y luego conecte el conjunto a la fuente de alimentación.

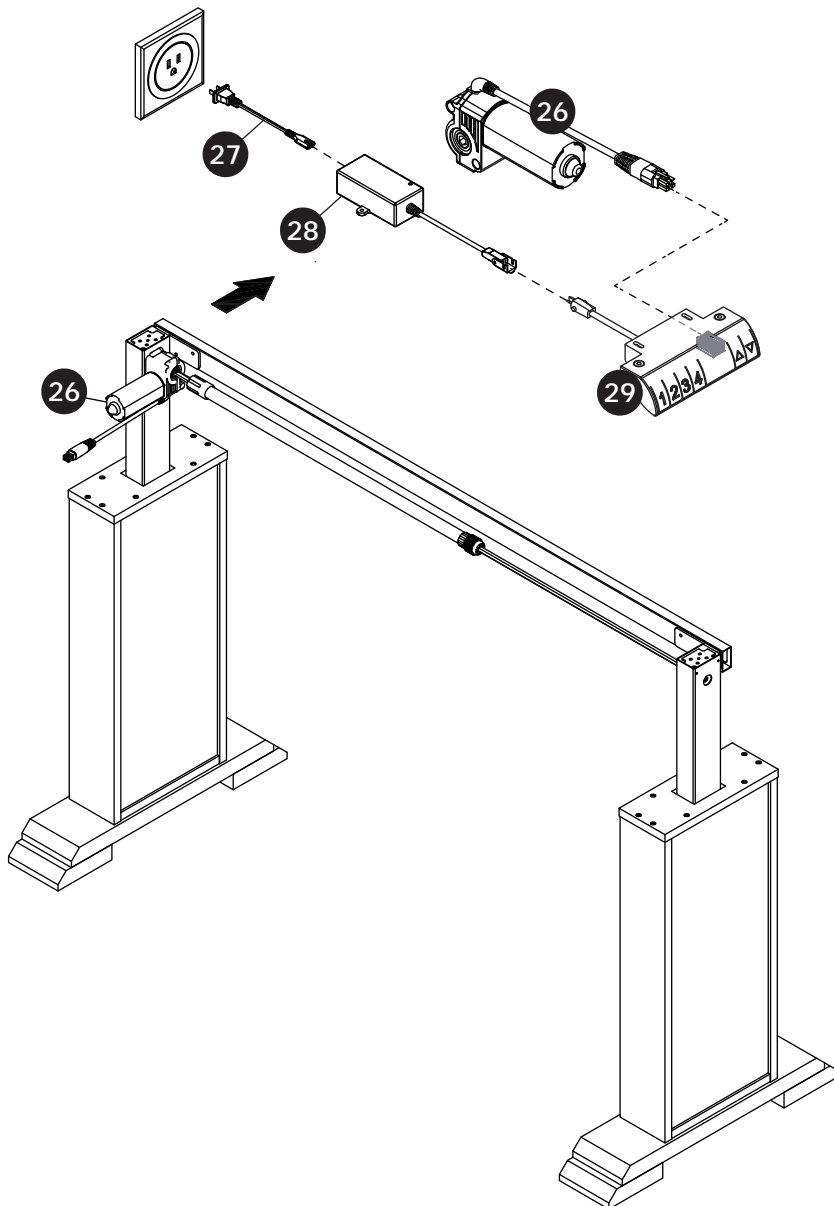

# 16

[EN] Raise Steel Frame to the highest position using Part (29).

[ES] Suba el marco de acero hasta la posición más alta con la pieza (29).

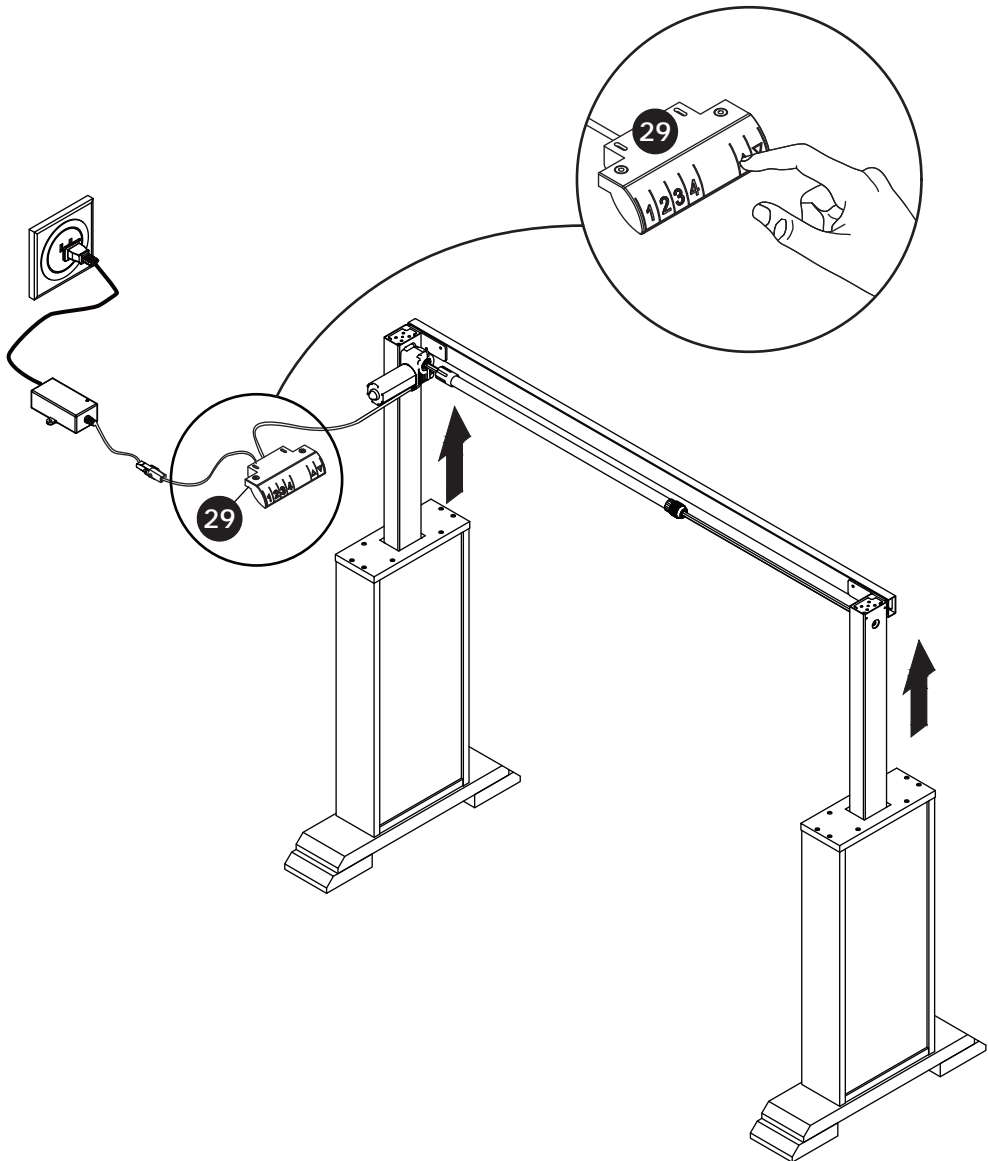

# 17

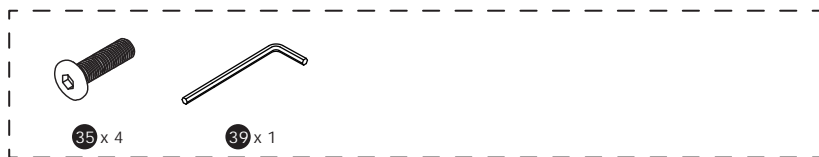

[EN] Connect Steel Frame 25 to Steel Frame 30 with screws (35).

[ES] Fije el marco de acero 25 al marco de acero 30 con tornillos (35).

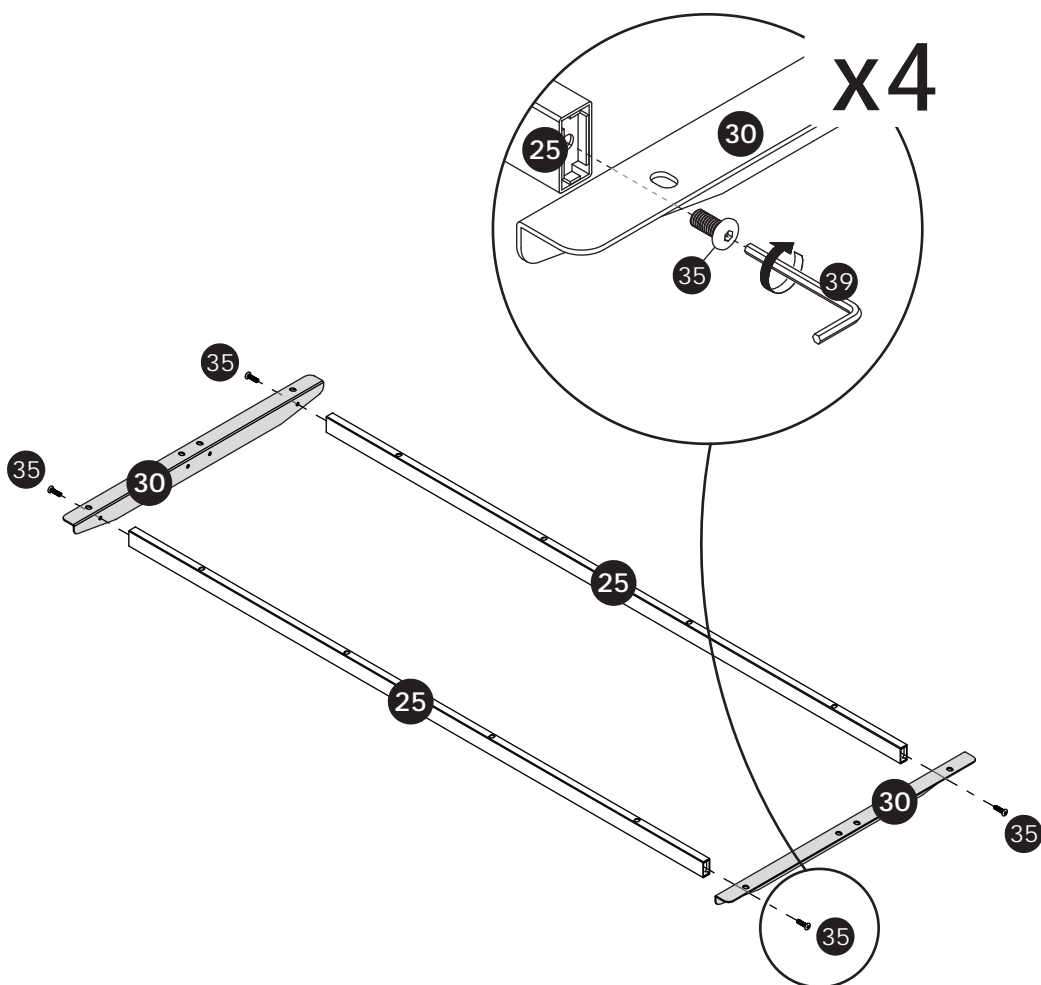

# 18



[EN] Connect Steel Frame 30 to Steel Frames 21 and 22 using screws (33).

[ES] Conecte el marco de acero 30 a los marcos de acero 21 y 22 con tornillos (33).

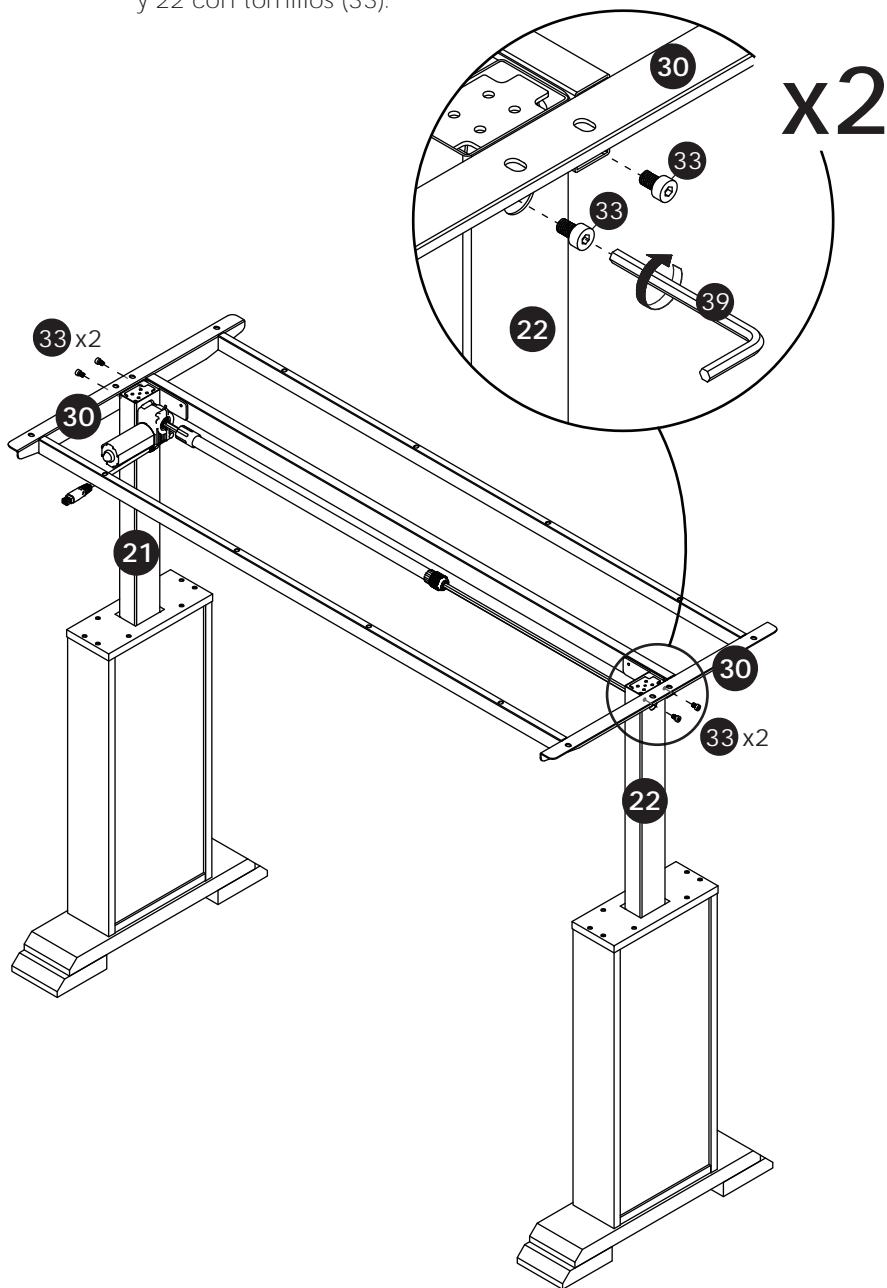

# 19



[EN] Connect Panel 2 with wooden dowels (G).

[ES] Conecte el panel 2 con espigas de madera (G).

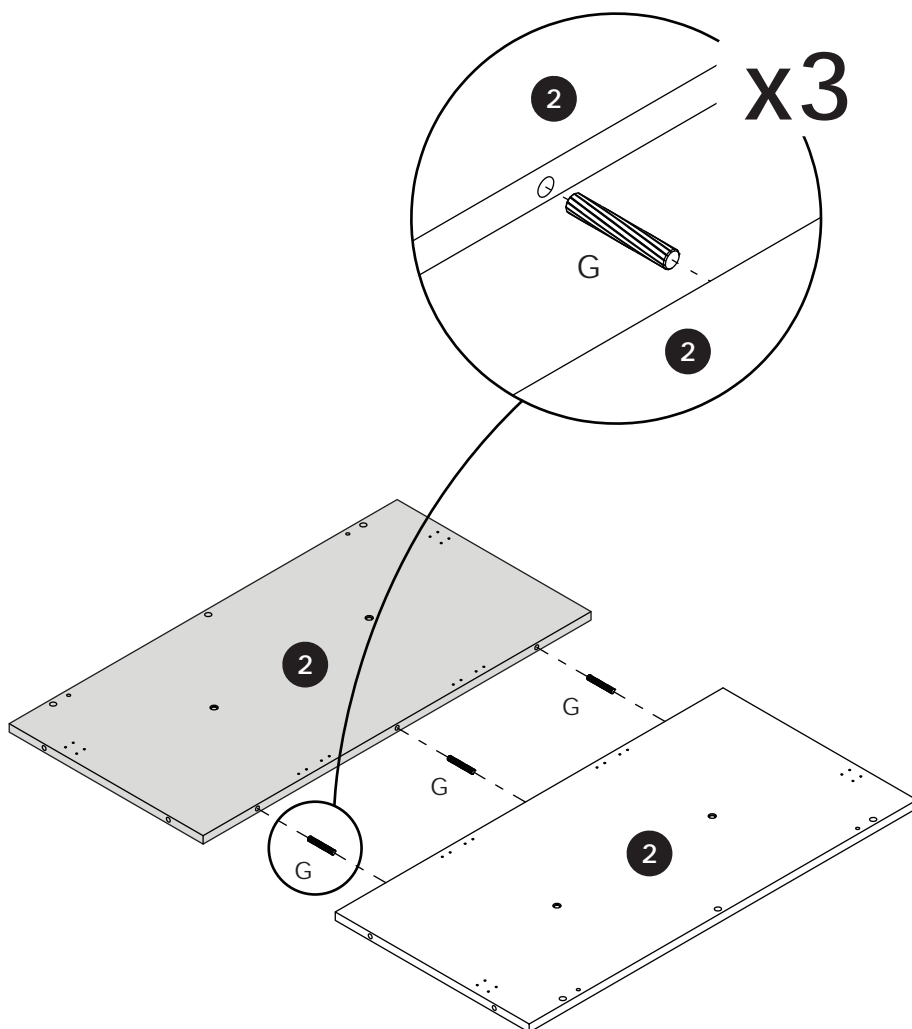

# 20



[EN] Connect Panel 1 to Panel 2 with wooden dowels (G).

[ES] Conecte el panel 1 al panel 2 con espigas de madera (G).

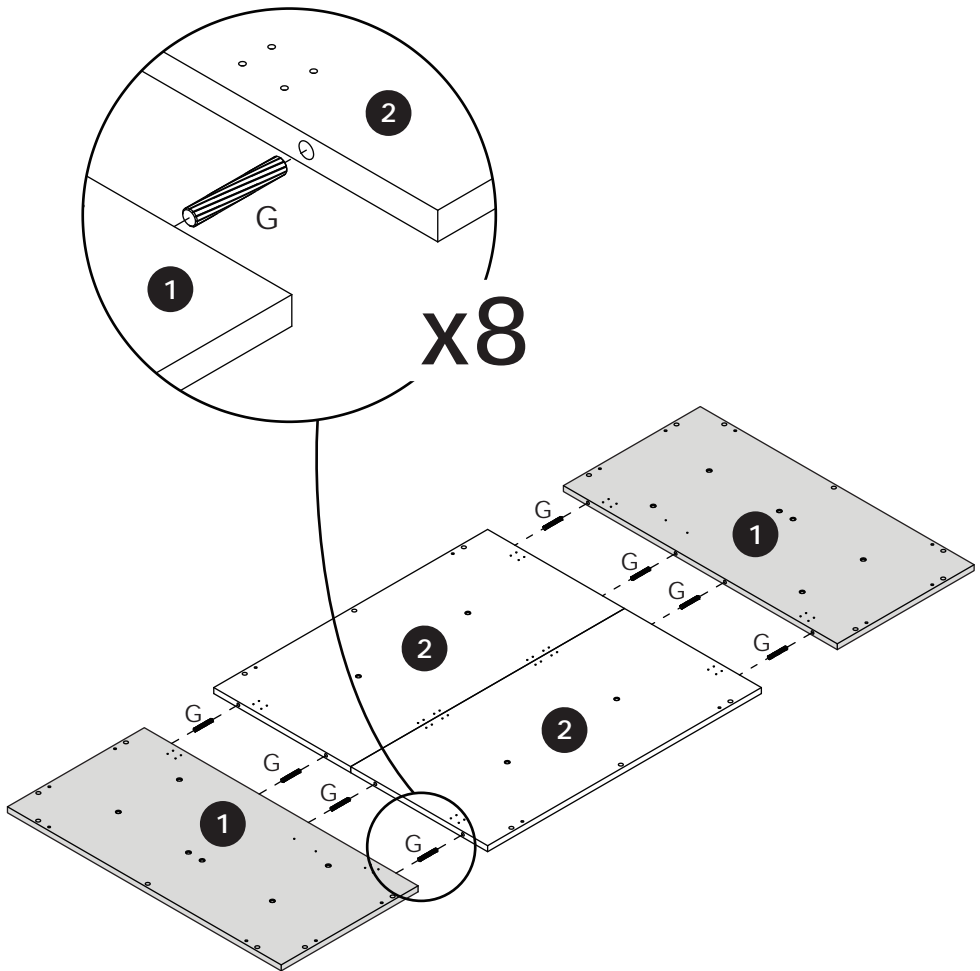

# 21



[EN] Secure Part (H) to Panel 1 and Panel 2 with screws (J).

[ES] Fije la pieza (H) al panel 1 y al panel 2 con tornillos (J).

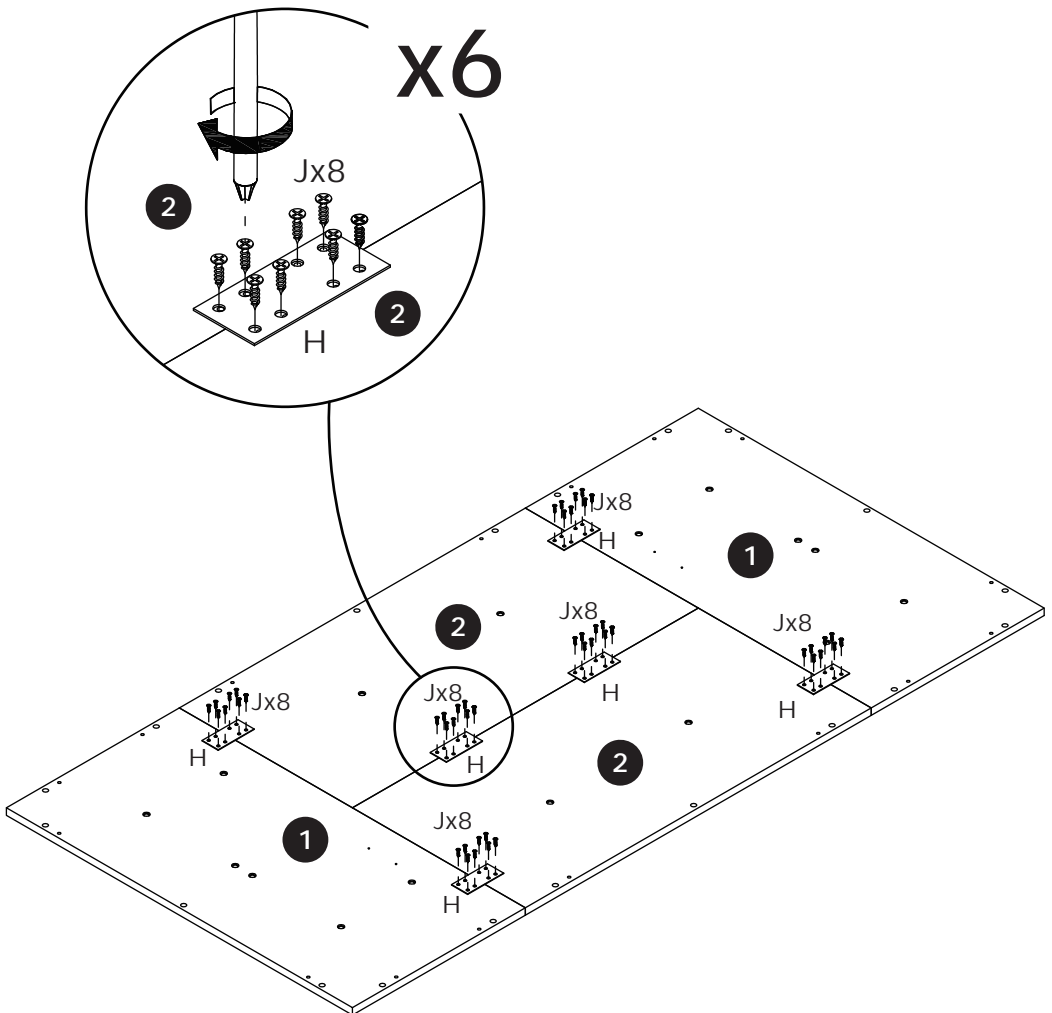

# 22



[EN] Install Part (B) onto Panel 1 and Panel 2, then screw the self-tapping rods (A) into them.

[ES] Instale la pieza (B) en el panel 1 y el panel 2, y luego atornille las varillas auto perforantes (A) en ellos.

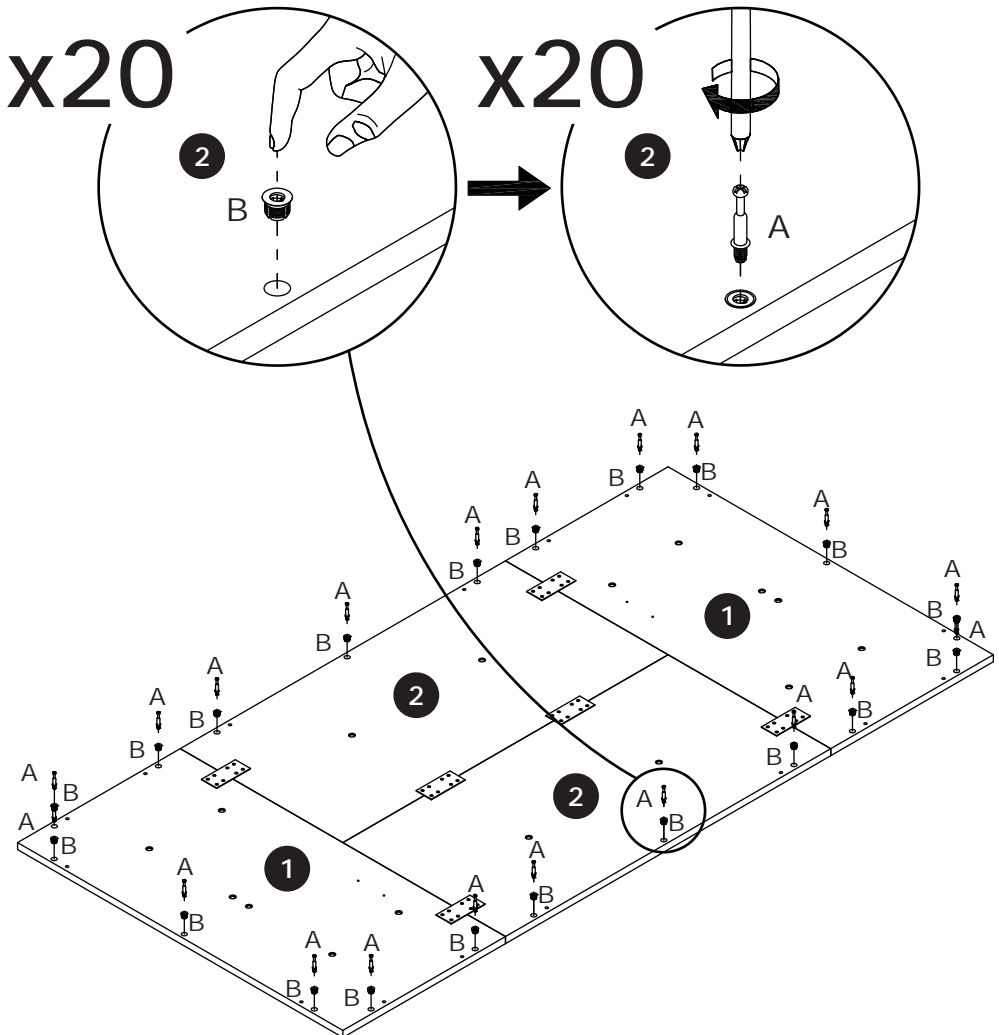

# 23



[EN] Connect Panels 3, 4, and 5, and Panels 7, 8, and 9 with wooden dowels (G).

[ES] Conecte los paneles 3, 4 y 5, y los paneles 7, 8 y 9 con espigas de madera (G).

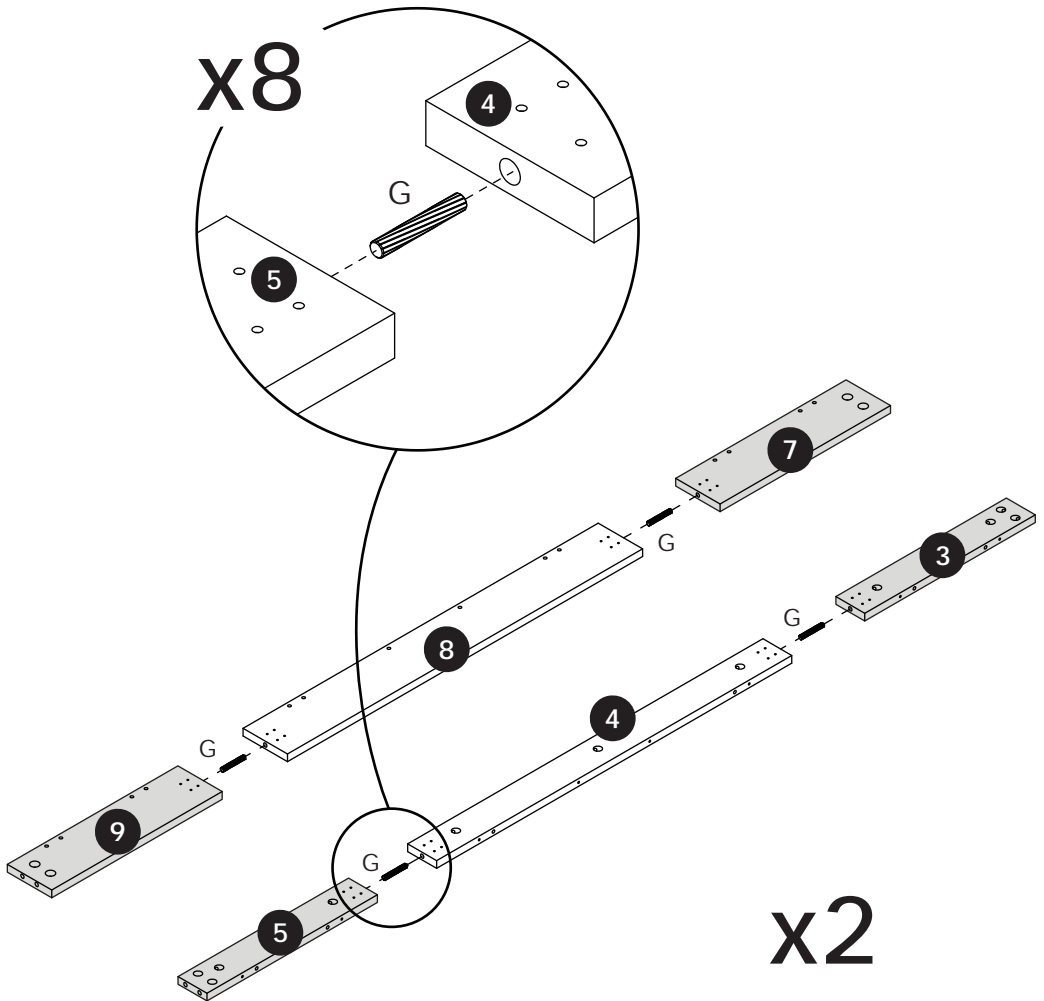

# 24



[EN] Secure Part (H) to Panels 3, 4, 5, 7, 8, and 9 with screws (J).

[ES] Fije la pieza (H) a los paneles 3, 4, 5, 7, 8 y 9 con tornillos (J).

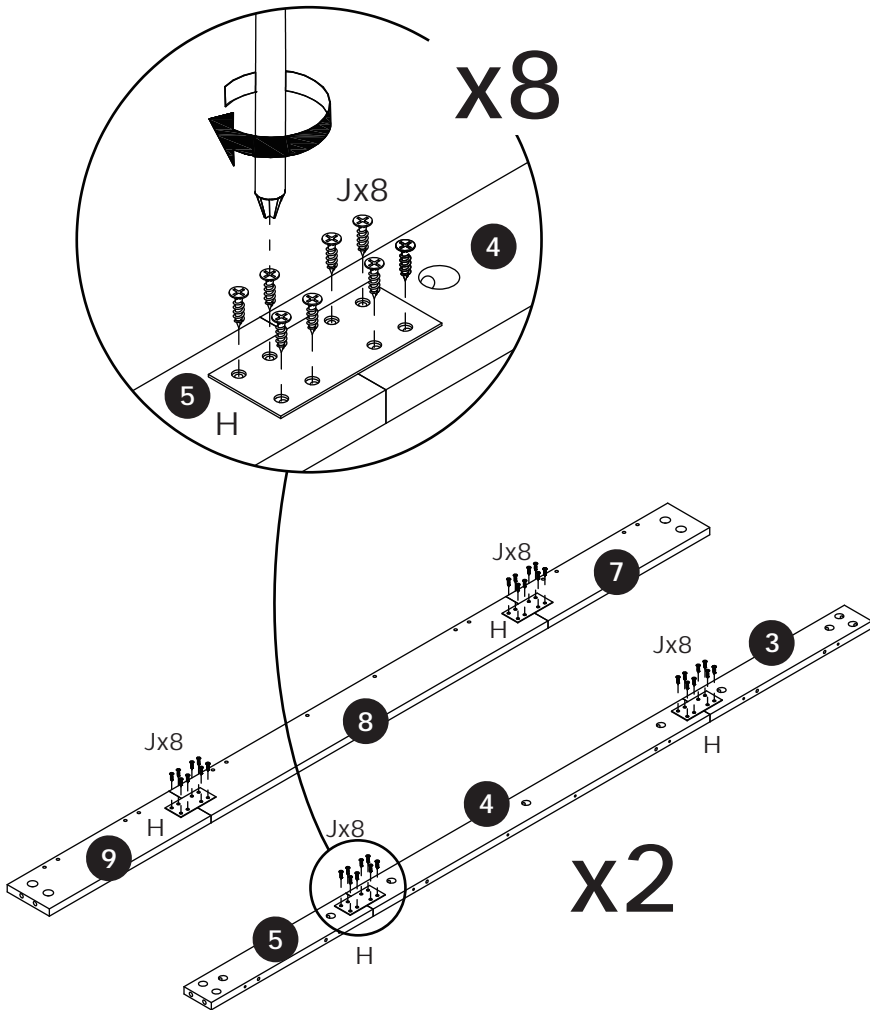

# 25



[EN] Connect Panels 3, 4, and 5 to Panels 7, 8, and 9 using wooden dowels (E), then secure them with screws (F).

[ES] Conecte los paneles 3, 4 y 5 a los paneles 7, 8 y 9 con espigas de madera (E), y luego fíjelos con tornillos (F).

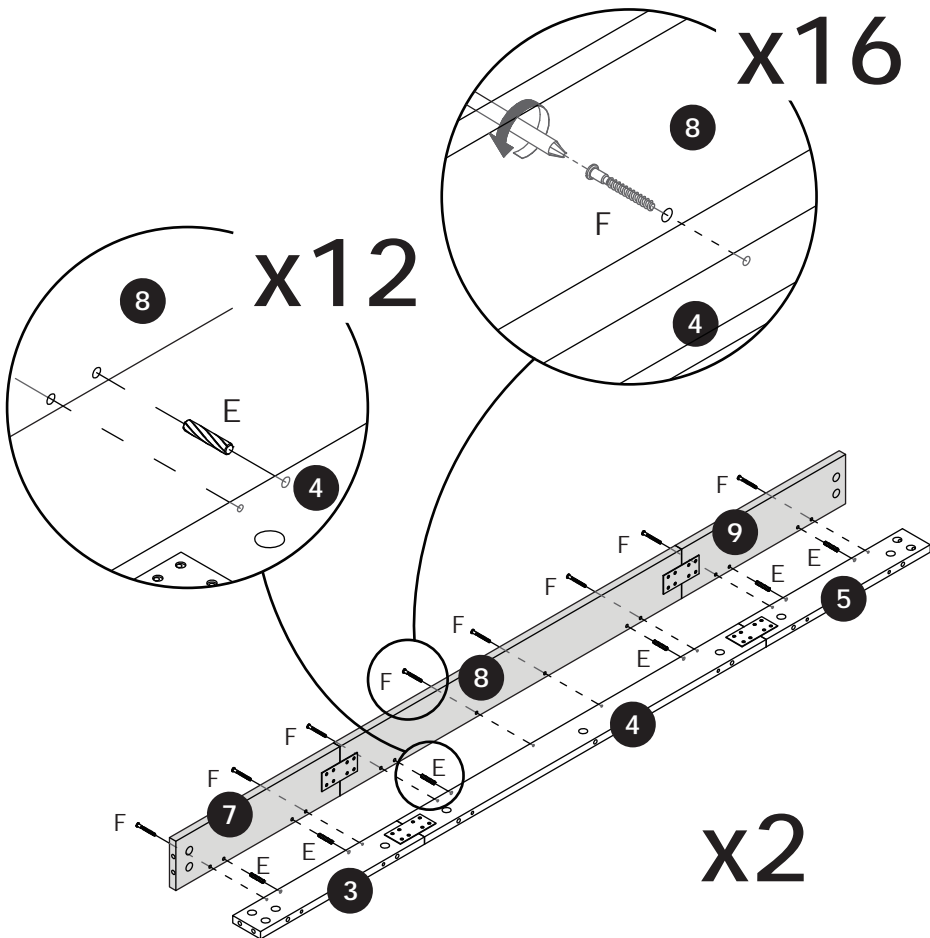

# 26



[EN] Install Part (B) onto Panel 6, then screw the self-tapping rods (A) into it.

[ES] Instale la pieza (B) en el panel 6 y luego atornille las varillas autoperforantes (A) en él.

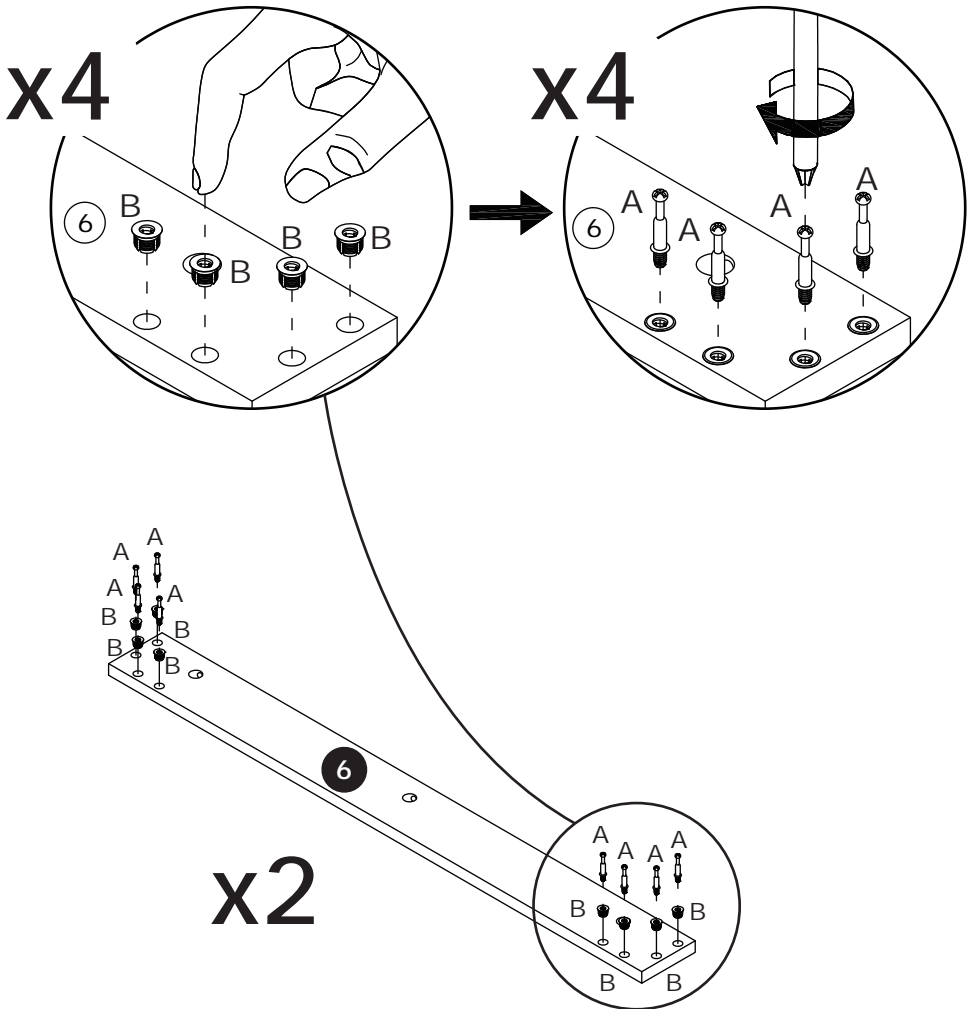

# 27



C x 16

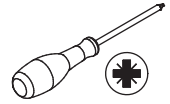

[EN] Connect Panel 6 to Panels 3, 5, 7, and 9, then install the eccentric cams (C) and tighten them clockwise.

[ES] Conecte el panel 6 a los paneles 3, 5, 7 y 9, y luego instale las levas excéntricas (C) y apriételas en el sentido de las agujas del reloj.

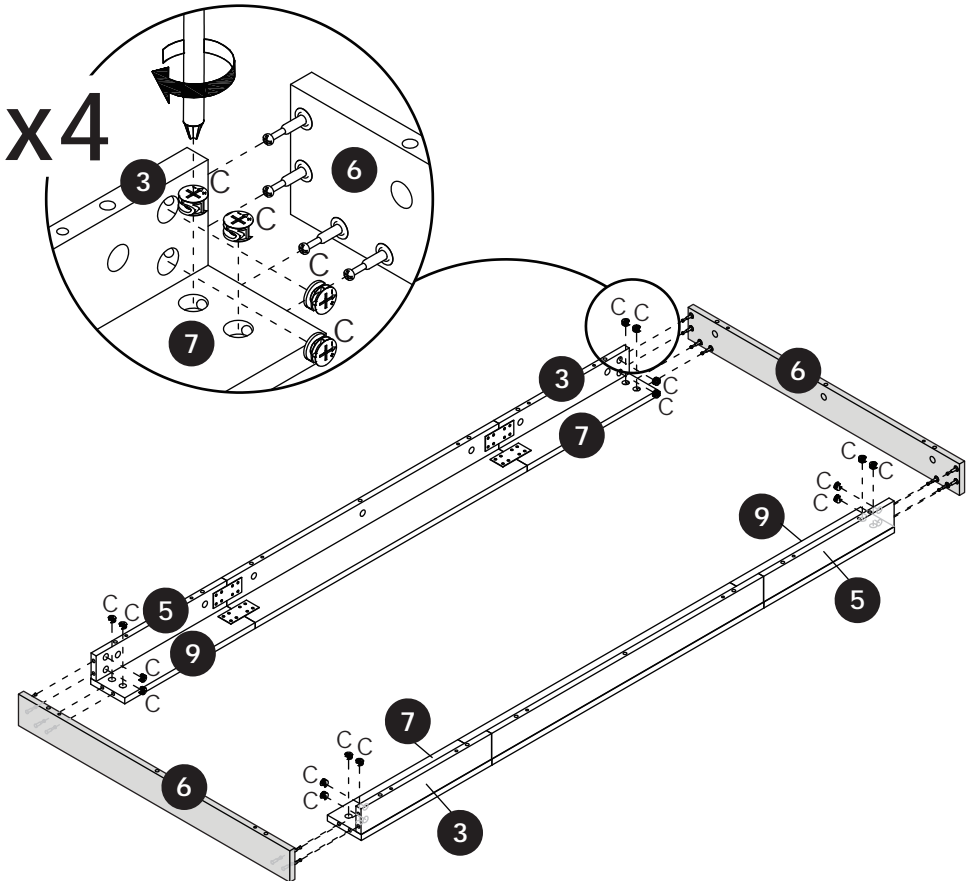

# 28



[EN] Insert wooden dowels (E) into Panels 3, 4, and 5.

[ES] Inserte las espigas de madera (E) en los paneles 3, 4 y 5.

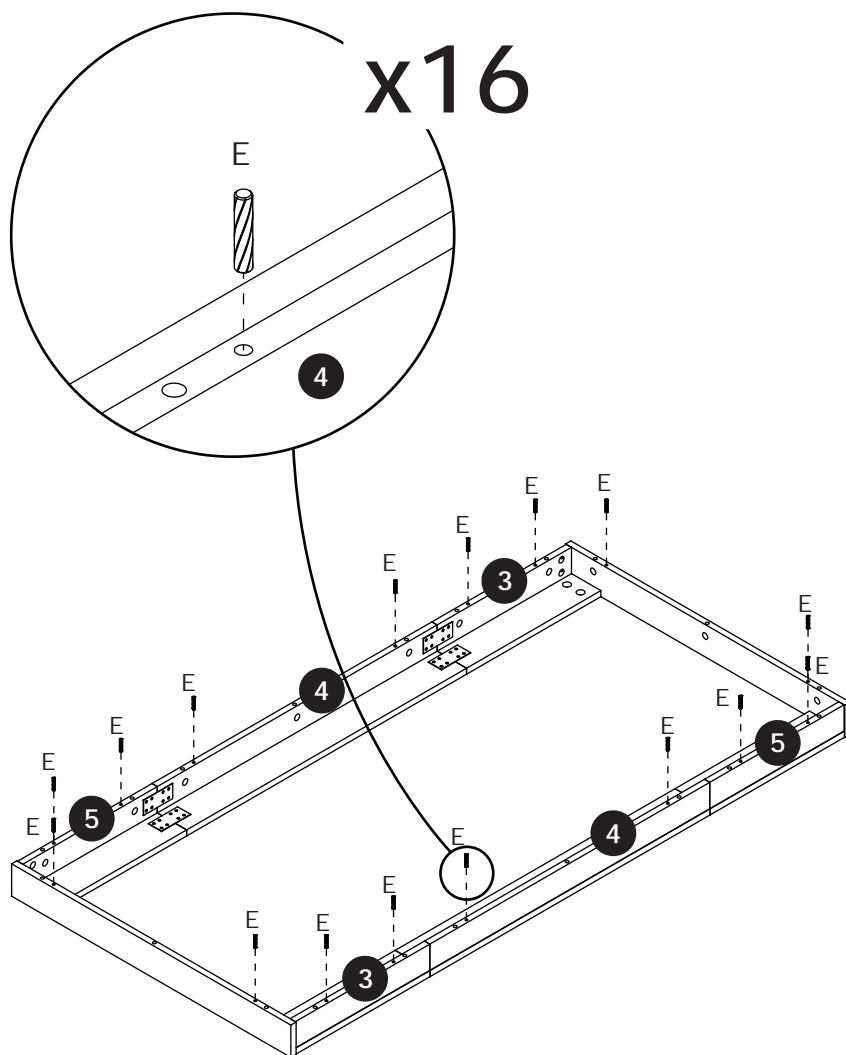

# 29



C x 20

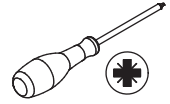

[EN] Connect Panels 3, 4, 5, and 6 to Panels 1 and 2, then install the eccentric cams (C) and tighten them clockwise.

[ES] Conecte los paneles 3, 4, 5 y 6 a los paneles 1 y 2, y luego instale las levas excéntricas (C) y apriételas en el sentido de las agujas del reloj.

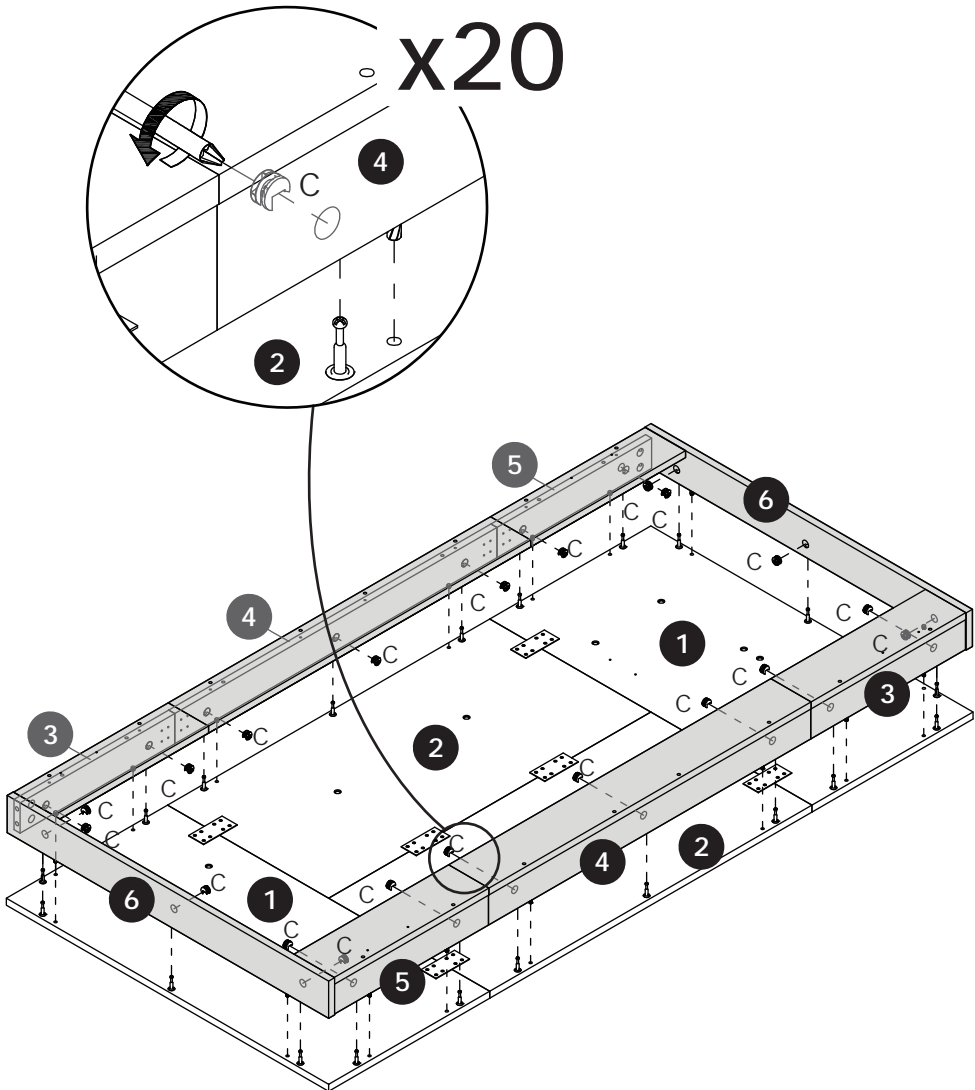





# 32



[EN] Secure the circuit with screws (J) and Part (L).

[ES] Fije el circuito con tornillos (J) y la pieza (L).

