

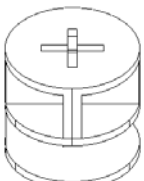





## DOORS 2 DRAWERS WARDROBE

### ASSEMBLY AND INSTALLATION GUIDE

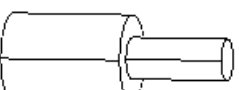
#### A LIST OF MATERIALS

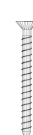
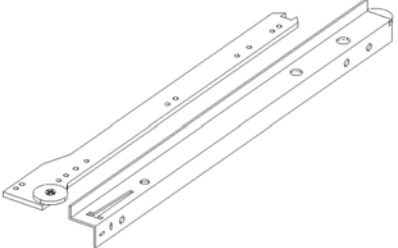
A	B	C	D	E	F	G
						

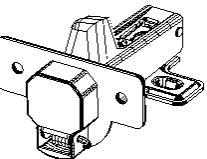
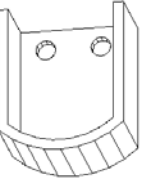
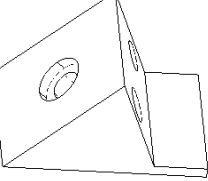
H	I	J	K	L
				

PIECES	QUANTITY
<b>A:MINIFIX BODY</b>	32
<b>B:MINIFIX SHAFT</b>	32
<b>C:DOWEL</b>	32
<b>D:SHELF PIN</b>	36
<b>E:3,5X17 SCREW</b>	70
<b>F:3,5X50 SCREW</b>	8
<b>G:3,5X30 SCREW</b>	7

PIECES	QUANTITY
<b>H:RAIL SET WITH 40</b>	2 SET
<b>I:FLAT HINGE</b>	6
<b>J:HUMP HINGE</b>	4
<b>K:FLANGE</b>	2
<b>L:BACK FIXER</b>	10
<b>M:HANGER PIPE</b>	1

Contact Information; Phone Number: +90 332 502 00 36

E-mail: sales@rabimobilya.com.tr

**NOTE: Please have at least one assistant available during the cabinet installation!**

## 4 DOORS 2 DRAWERS WARDROBE

-Before starting the assembly, take all the parts out of the box and check them according to the assembly manual.

-Before starting the assembly, clean each part with a damp cloth.

-Although the products are carefully checked and packaged, if you encounter a problem during shipping, you can check the necessary parts and send an e-mail to [sales@rabimobilya.com.tr](mailto:sales@rabimobilya.com.tr) or contact us at the contact numbers on our website. The problem will be fixed as soon as possible free of charge.

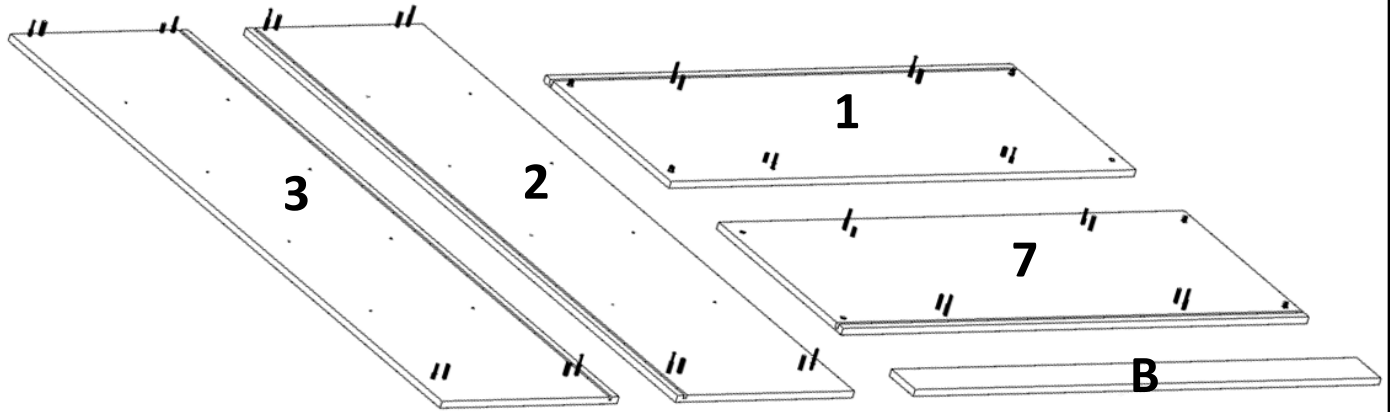

1	2	3	4	5	6	7	B
BOTTOM TABLE	RIGHT SIDE	LEFT SIDE	RIGHT MIDDLE FIXING	LEFT MIDDLE FIXING	FIXED SHELF	UPPER TABLE	BASE
1 PIECE	1 PIECE	1 PIECE	1 PIECE	1 PIECE	1 PIECE	1 PIECE	2 PIECE

S	S1
MOVING SHELF	MOVING SHELF
1 PIECE	8 PIECE

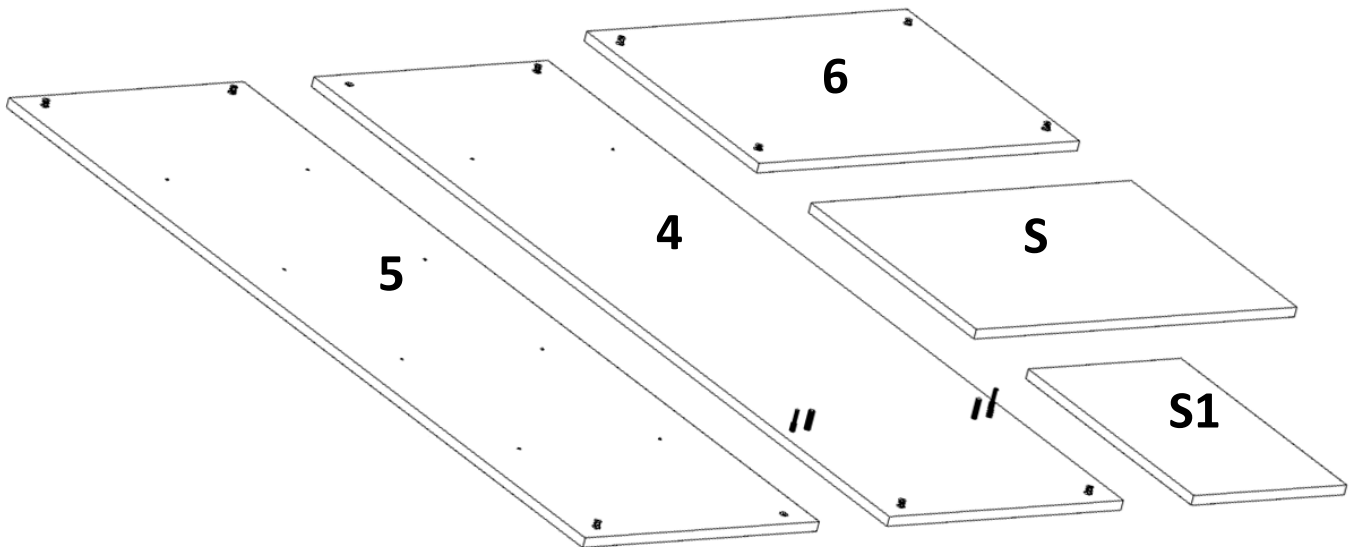

**NOTE: Please have at least one assistant available during the cabinet installation!**

## PIECES DIMENSIONS

LENGTH	WIDTH	QUANTITY	EXPLANATION
1800	520	1	RIGHT SIDE(2)
1800	520	1	LEFT SIDE(3)
1368	520	1	BOTTOM TABLE(1)
1368	520	1	UPPER TABLE(7)
1668	500	1	RIGHT MIDDLE FIXED(4)
1668	500	1	LEFT MIDDLE FIXING(5)
684	500	1	FIXED SHELF(6)
684	480	1	MOVING SHELF
326	480	8	MOVING SHELF
1368	100	2	BASE(B)
627	100	4	DRAWER SPACER
400	100	4	DRAWER SIDE

### DOORS

1698	347	1	RIGHT OUTER DOOR
1698	347	1	LEFT OUTER DOOR
1344	347	1	RIGHT MIDDLE DOOR
1344	347	1	LEFT MIDDLE DOOR
698	174	2	DRAWER FRONT COVER

### BACKREST

1682	461	3	WHITE BACK
641	382	2	WHITE BACK

**NOTE: Please have at least one assistant available during the cabinet installation!**

Start our cabinet by fixing the plinth legs as shown in figure 1. Fix the plinth feet with 3.5\*50 screws with the help of a cordless drill.

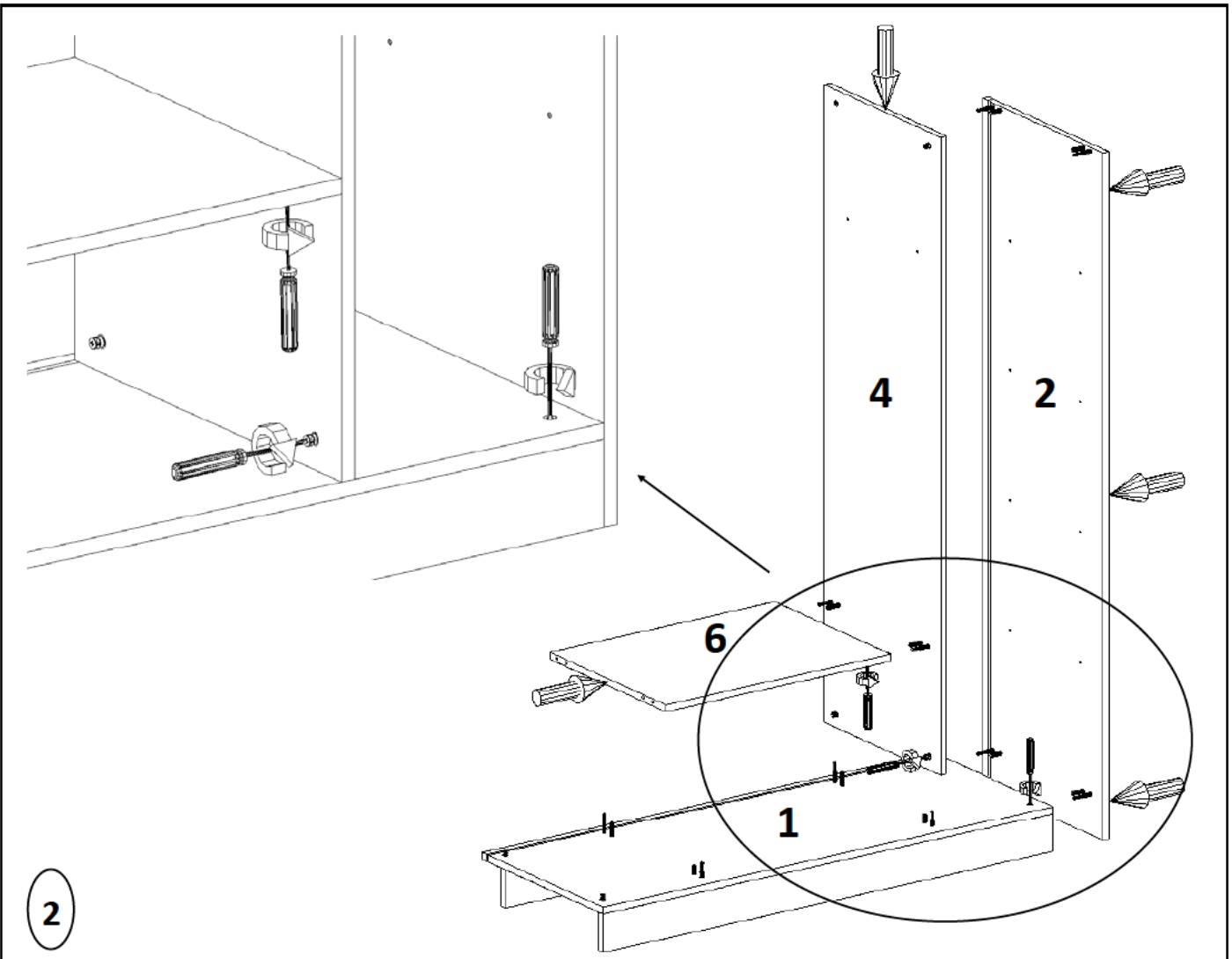
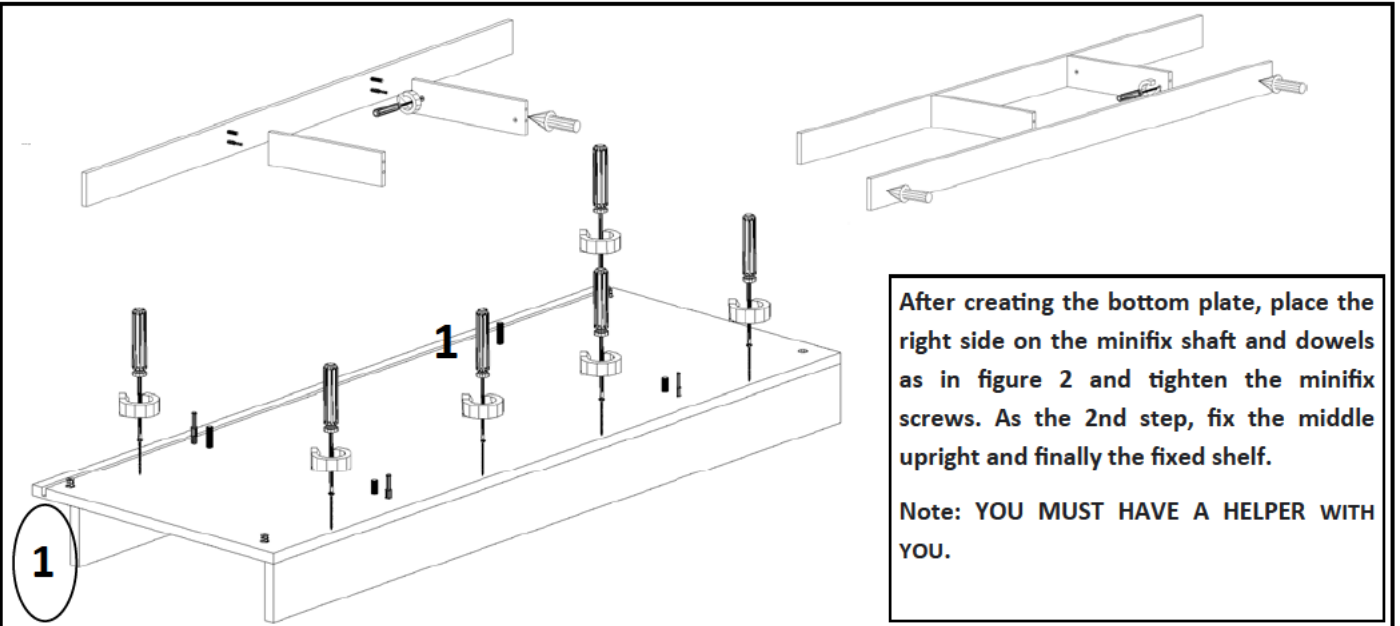

Place the left middle pillar of the cabinet on the minifix shaft and dowels as in figure 3 and tighten the minifix screws. Then place the left side on the minifix shaft and dowels and fix it.

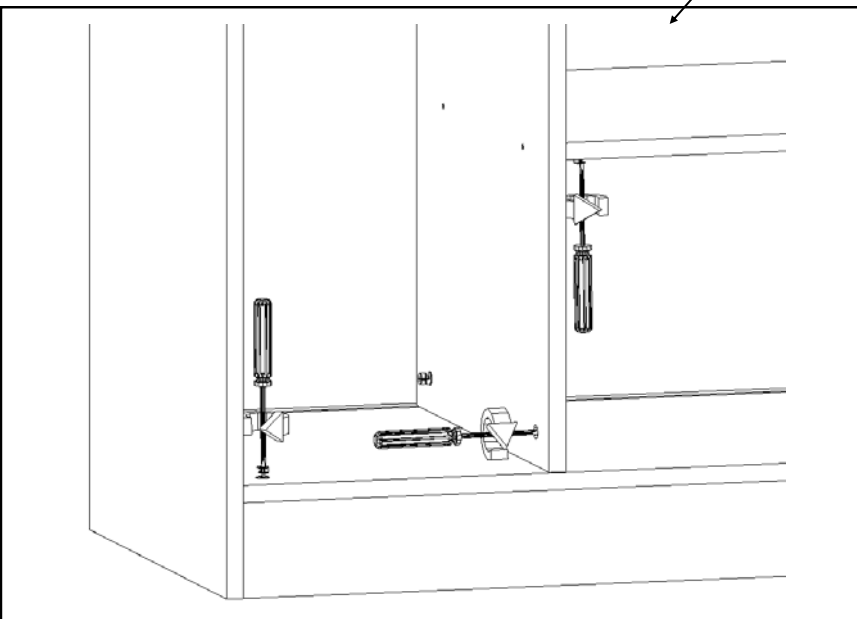
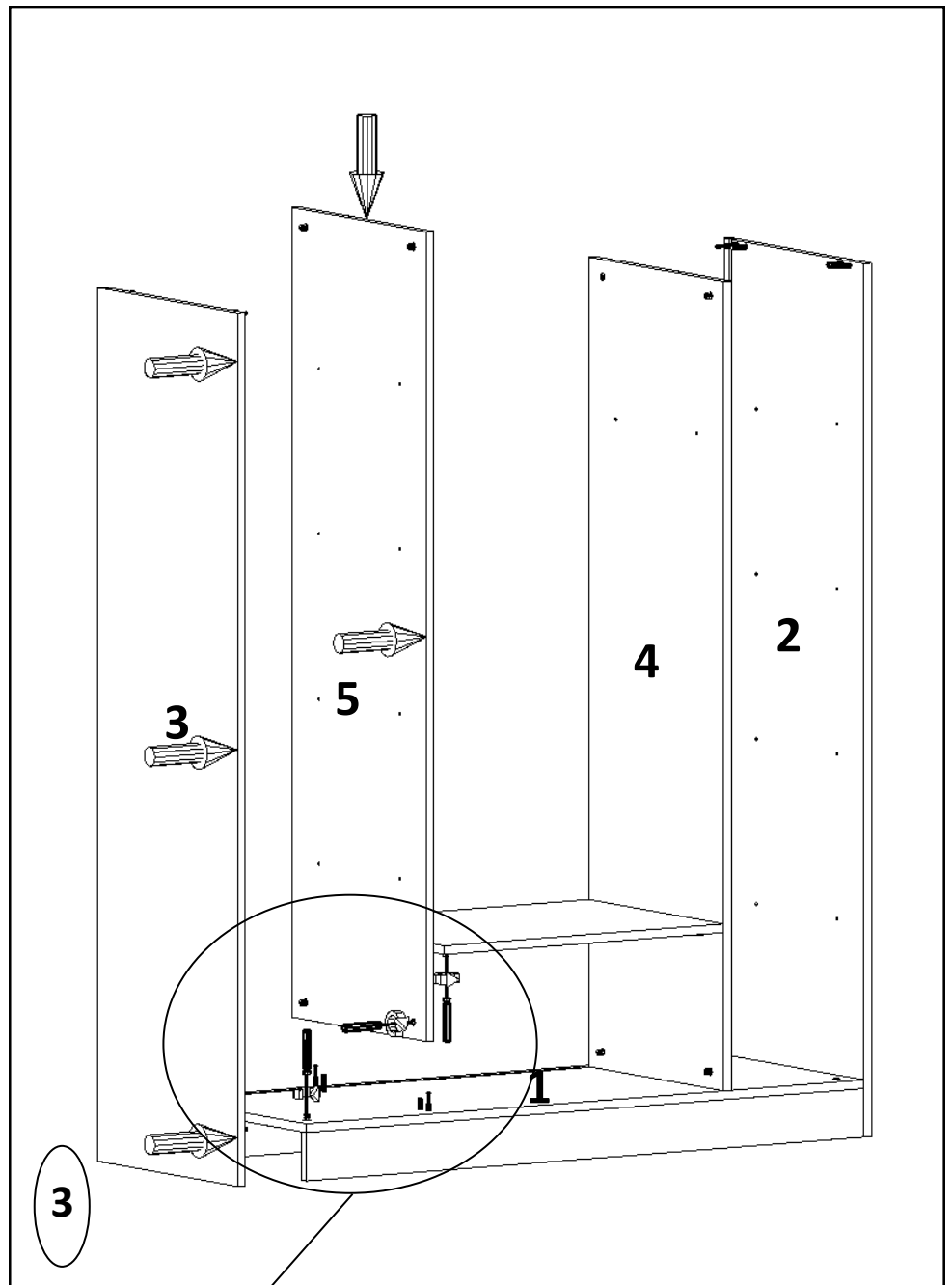

**NOTE: Please have at least one assistant available during the cabinet installation!**

Insert the back of the cabinet into the channel as in Figure 4. After this process, place and fix the top plate of the cabinet as in figure 5. Fix the hanger pipe flanges with 3.5x17 screws from the designated holes.

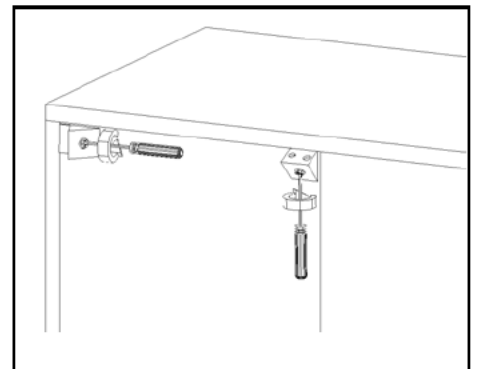
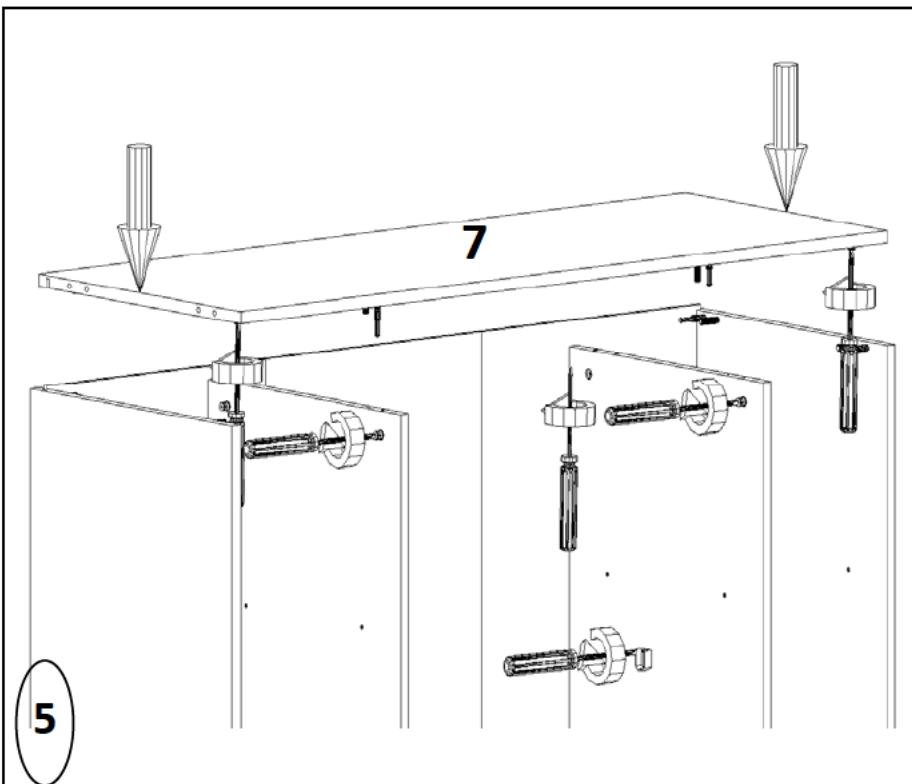
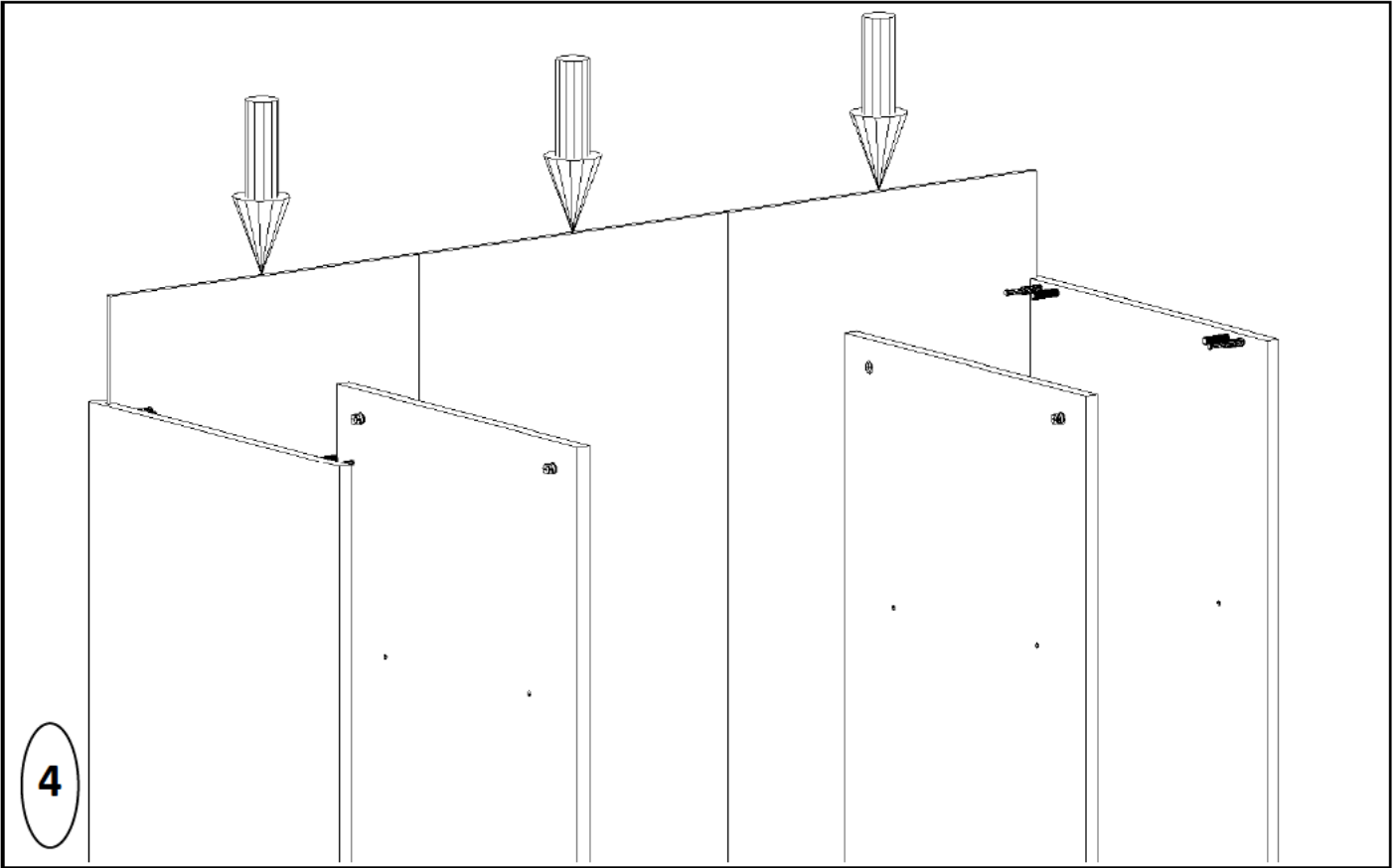

The body of the cabinet is complete. After this process, fix the backrest stabilizers with 3.5x17 screws.

**NOTE: Please have at least one assistant available during the cabinet installation!**

Insert the shelf pins of the cabinet And place the movable shelves. Attach the cabinet door as in figure 6 and fix it through the determined screw holes . There are two types of hinge groups. Attach half camel hinges (bent neck) hinges to the middle doors. Attach flat hinges to other covers. After the cover process, install the handle screws and fix the handles.

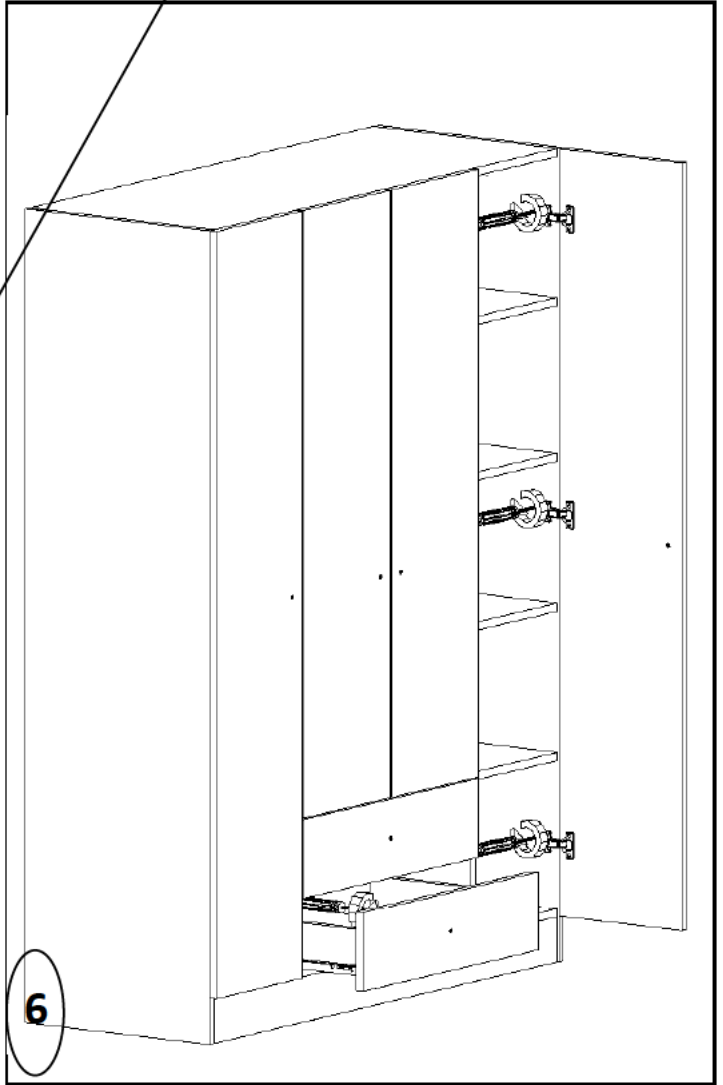
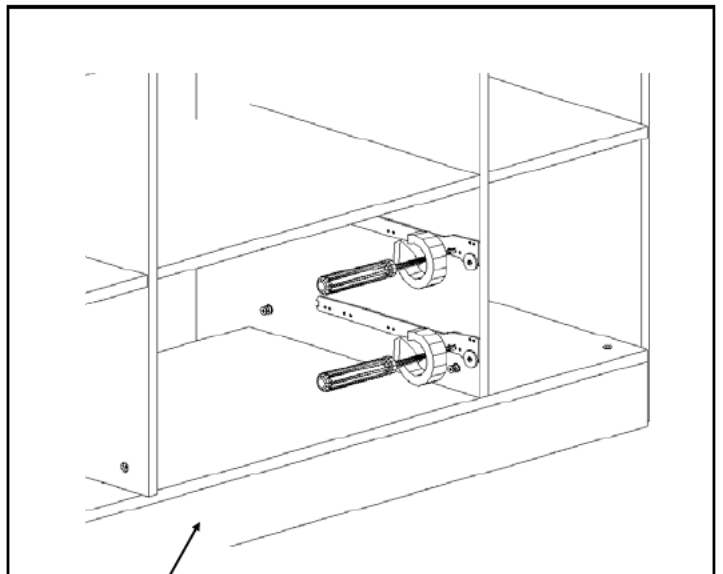
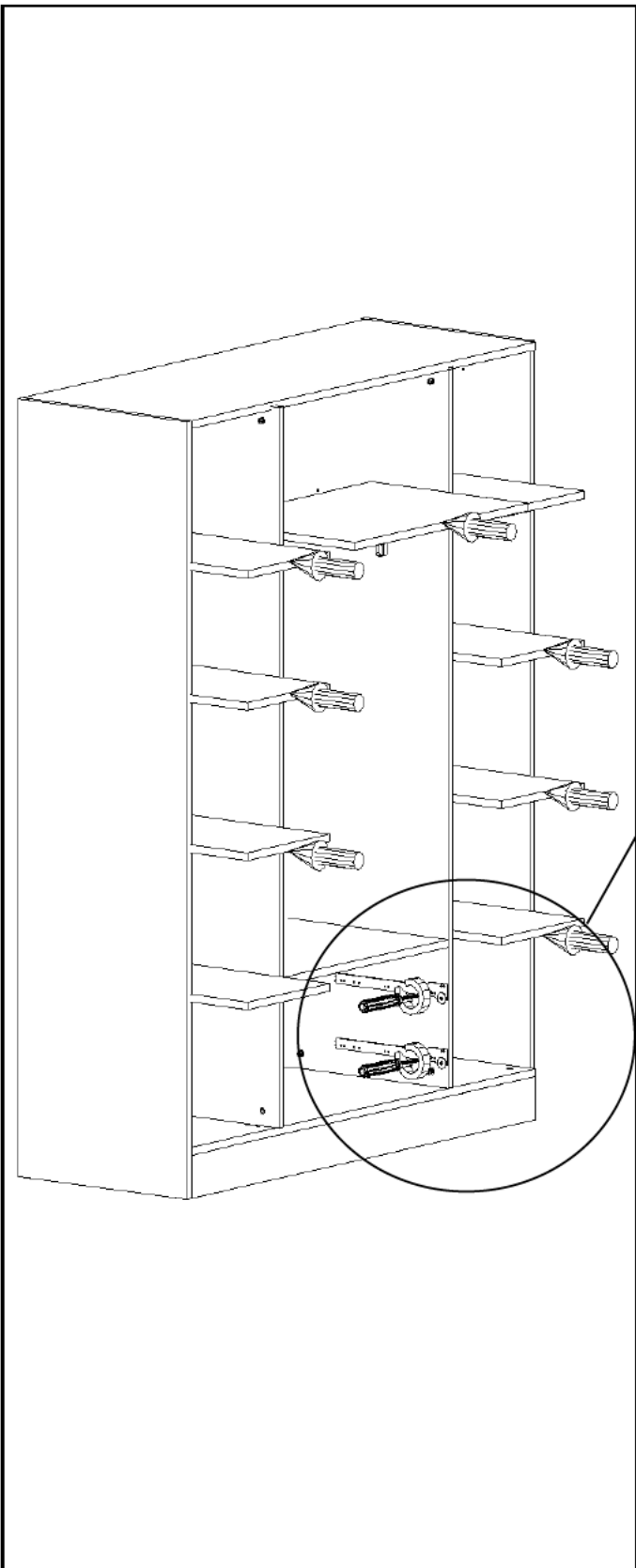

**NOTE: Please have at least one assistant available during the cabinet installation!**

Start the assembly of the cabinet from the left crown first. Reset the crown to the back of the cabinet as shown in Figure 6 and fix the crown from the inside of the cabinet to the crown with a 3.5x30 screw with the help of a cordless drill. Then fix the long crown from the inside of the cabinet by joining them at the 45-degree corner points. Repeat the same process for the last piece.

7

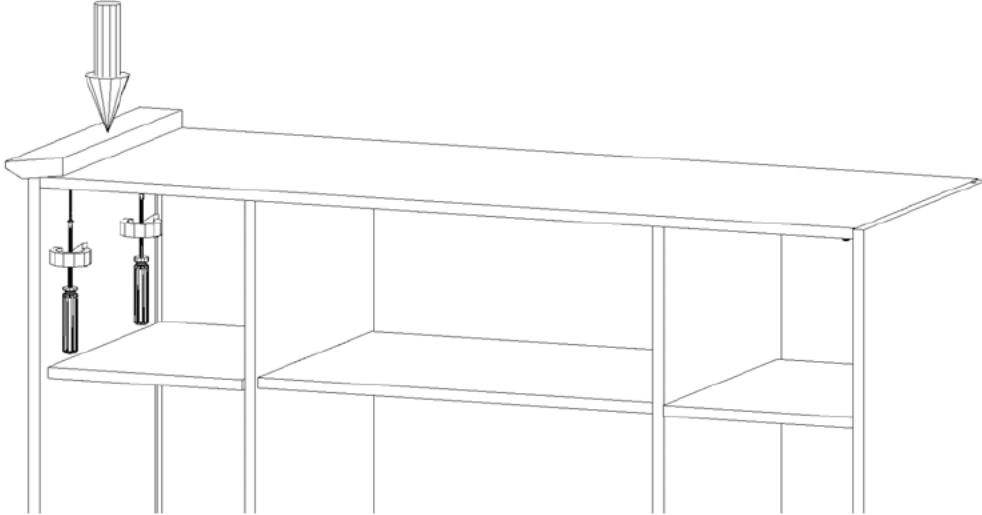

8

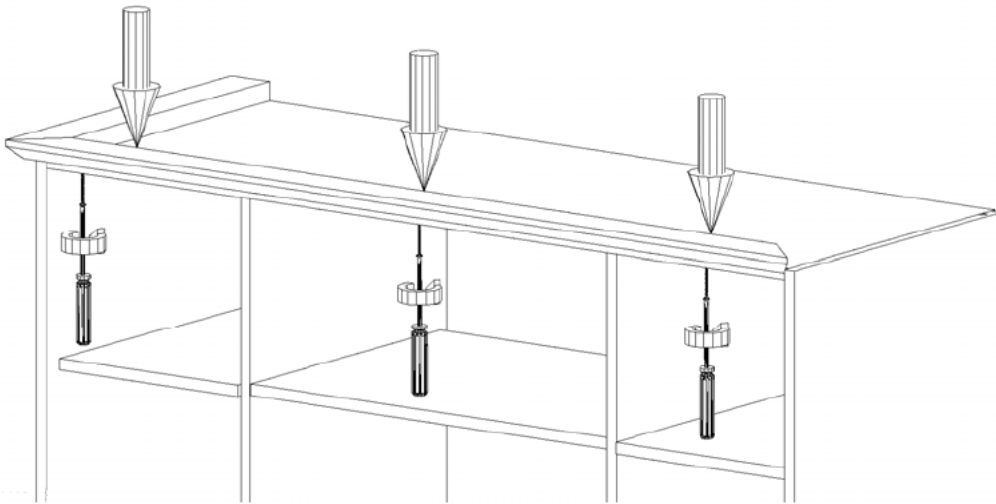

9

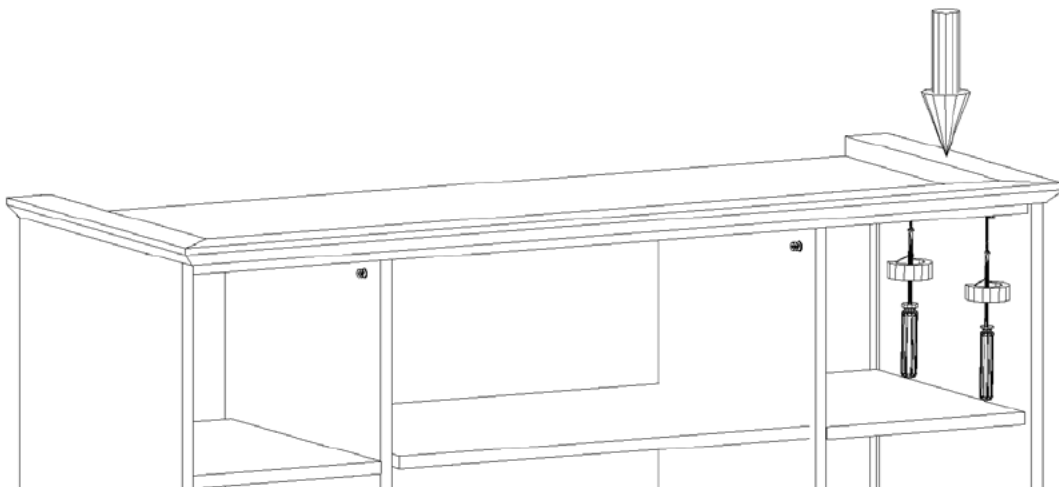

**NOTE: Please have at least one assistant available during the cabinet installation!**

(THE CROWN CONNECTION SHOWN FOR INSTALLATION IN THE IMAGES IS NOT INCLUDED IN OUR GOLD GROUP PRODUCTS THAT WE MANUFACTURED.)

## DRAWER CASE INSTALLATION

Before starting the drawer case, place the furniture materials as in figure 1. Place the chipboard panels on the minifix shaft and dowels as in figure 2 and fix the minifix screws. Insert the backrest into the channel. Then place the drawer front flap on the minifix shaft and dowels as in figure 4 and fix the minifix screws. Turn the safe we created 180 degrees and fix the drawer rail with a 3.5x17 screw with the help of a cordless drill as in the figure.

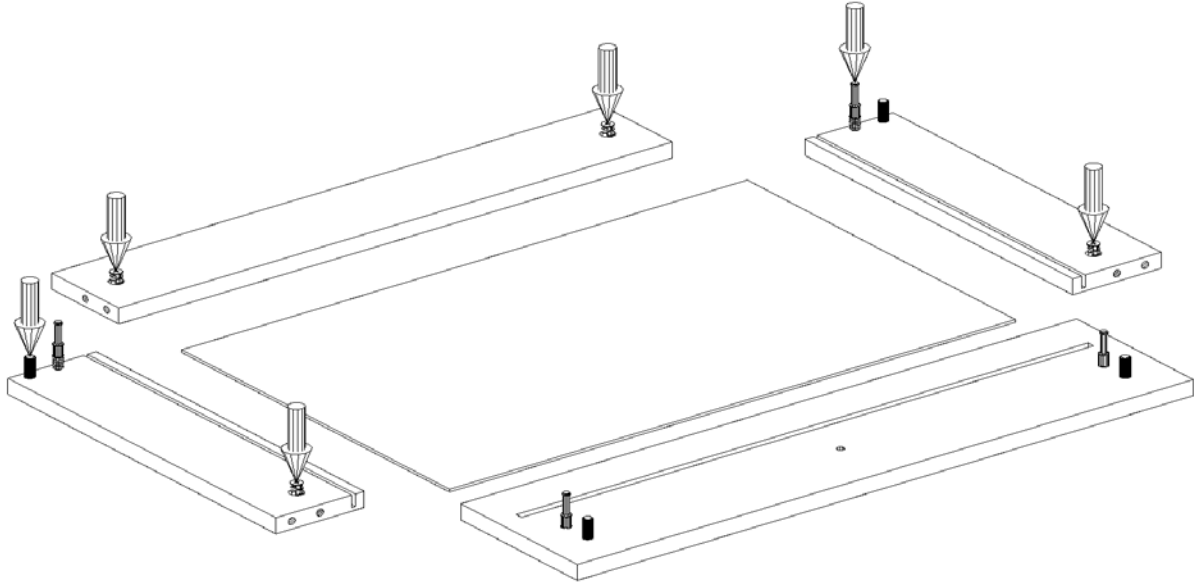
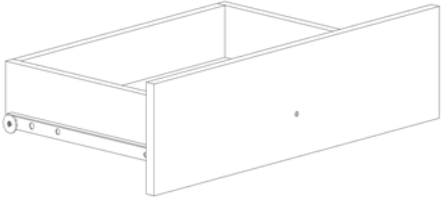

1

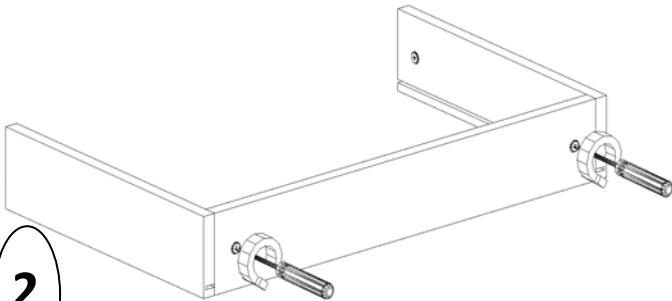

2

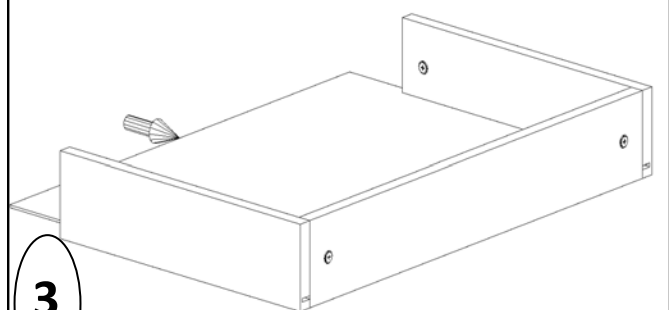

3

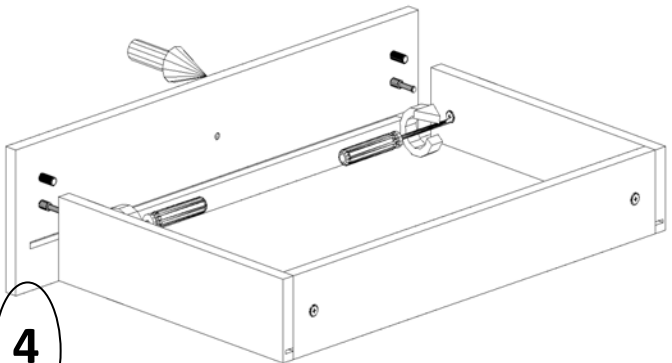

4

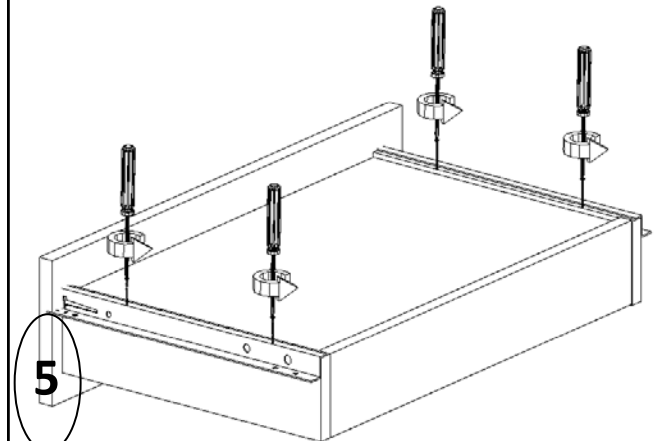

5

**NOTE: Please have at least one assistant available during the cabinet installation!**