



1  Ø15 x 23mm X5	2  M3.5 x 25mm X 30	3  Dia 15mm X45 9mm	4  M6.5 x 32mm X45	5  Dia 6 x 30mm X38
6  M4 x 20mm X8	7  M4 x 10mm X10	8  BACKPLY STOPPER X8	9  M3 x 20mm X8	10  M3.5 x 12mm X10
11  M8 x 38mm X1	12  M3.5 x 12mm X60	13  Glue 10cc X2	14  HANDLE X5	15  PVC H X1
16  M3.5 x 16mm X2	17  ANTI TIP STRAP X2	18  DRAWER RUNNER (RIGHT)-350mm X5	19  DRAWER RUNNER (LEFT)-350mm X5	20  DRAWER RUNNER (RIGHT)-350mm X5
21  DRAWER RUNNER (LEFT)-350mm X5				

PART LIST

- A** X1 **L** X1
- B** X1 **M** X5
- C** X1 **N** X5
- D** X1 **O** X5
- E** X1 **P** X5
- F** X2 **Q** X5
- G** X4 **R** X5
- H** X1 **S** X1
- I** X1
- J** X1
- K** X1

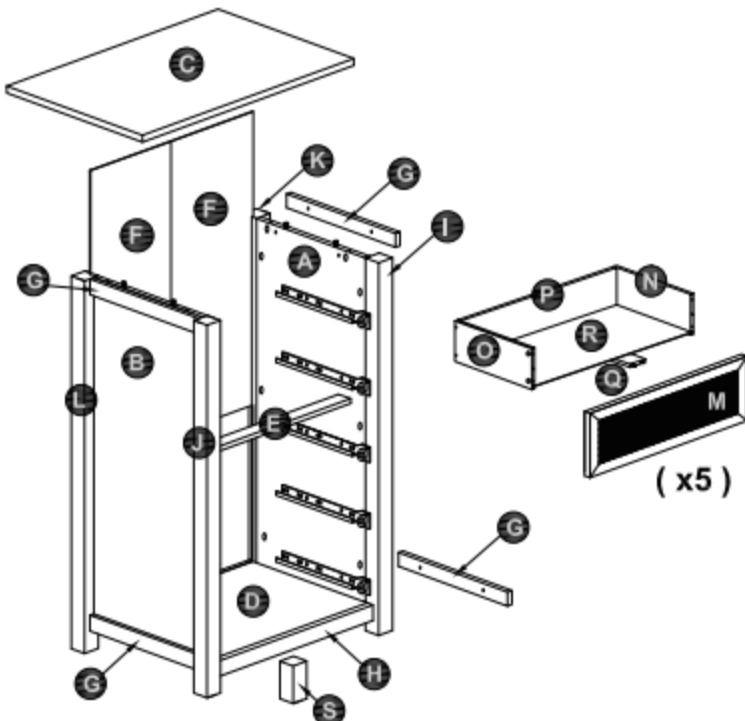
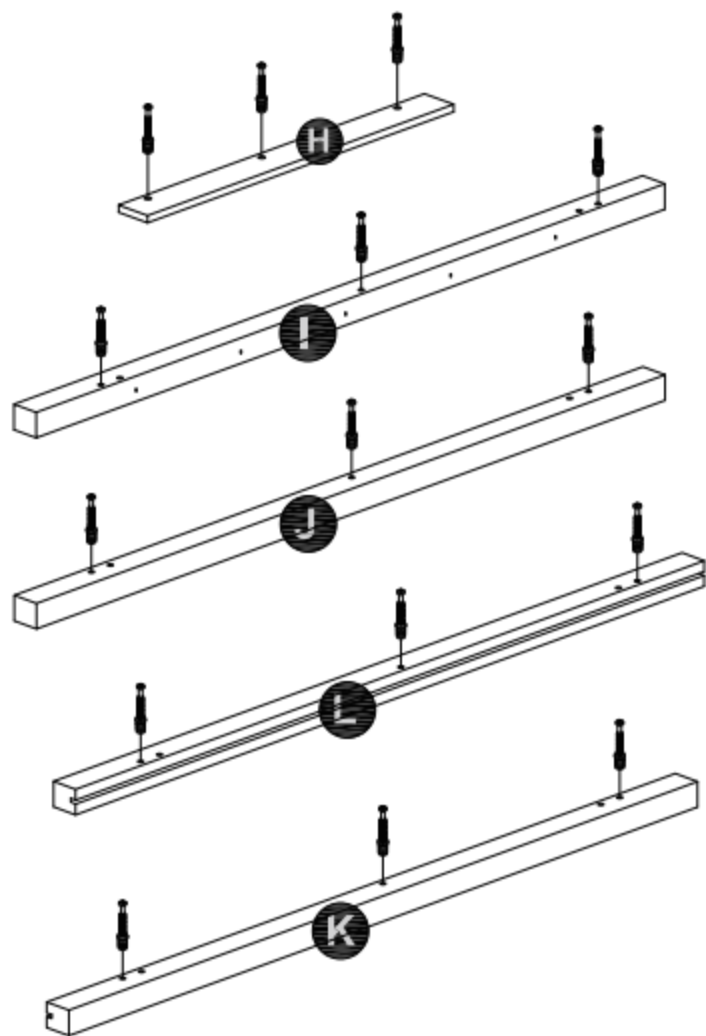
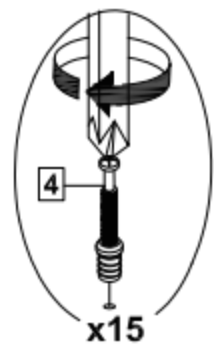

1

4

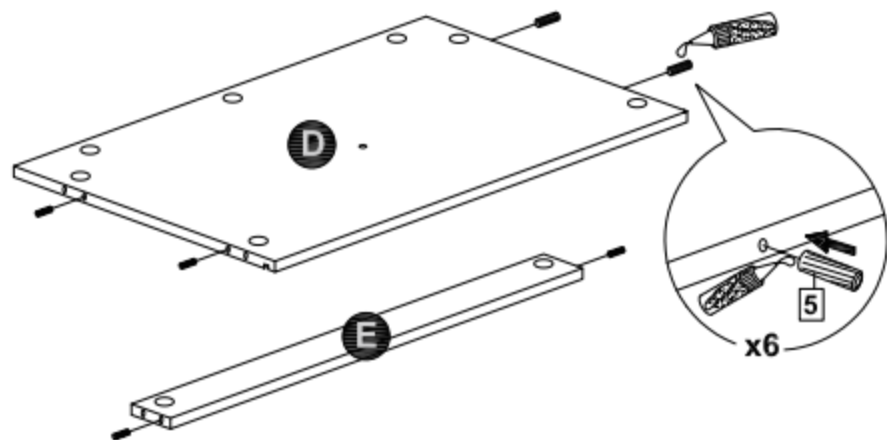
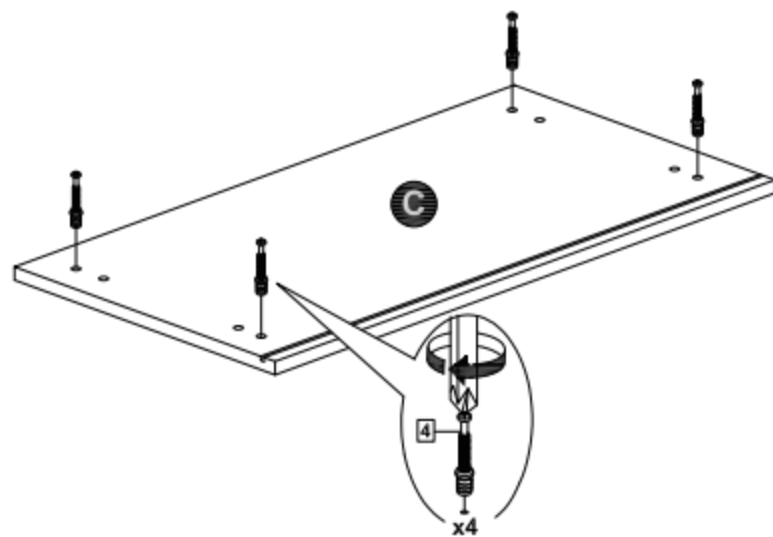
2**3**

5

8

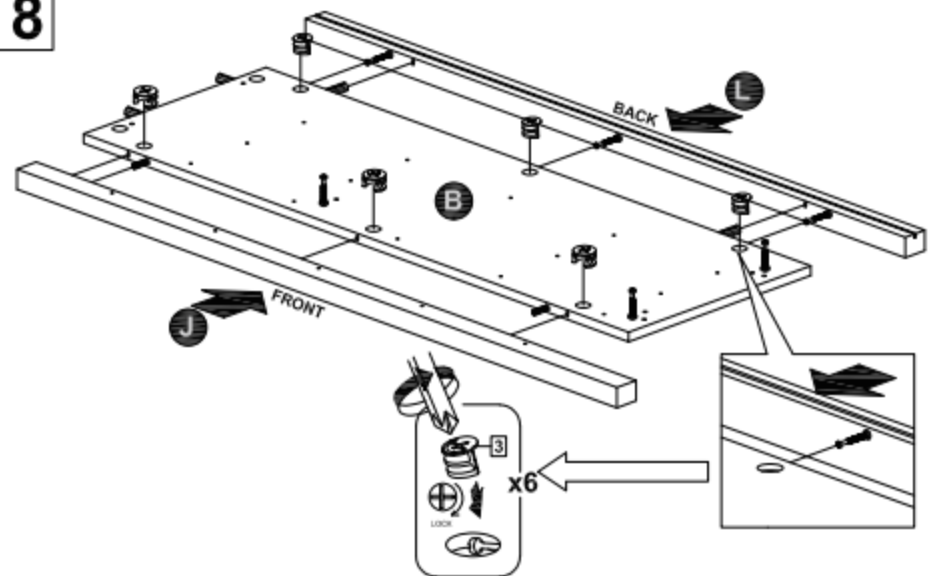

9

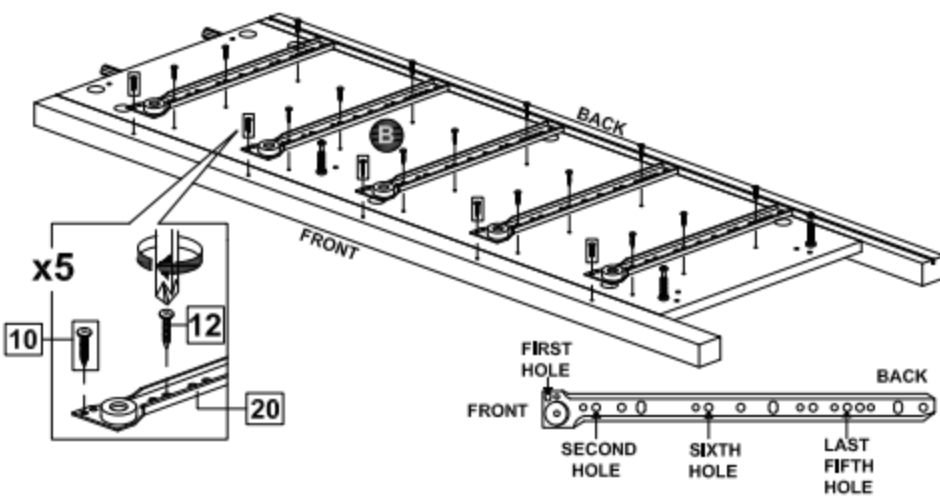

8

10

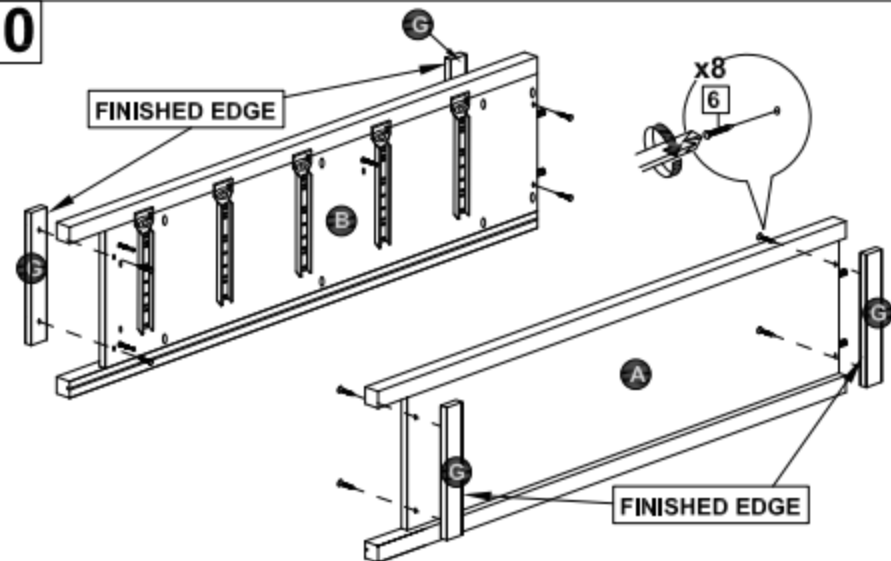

11

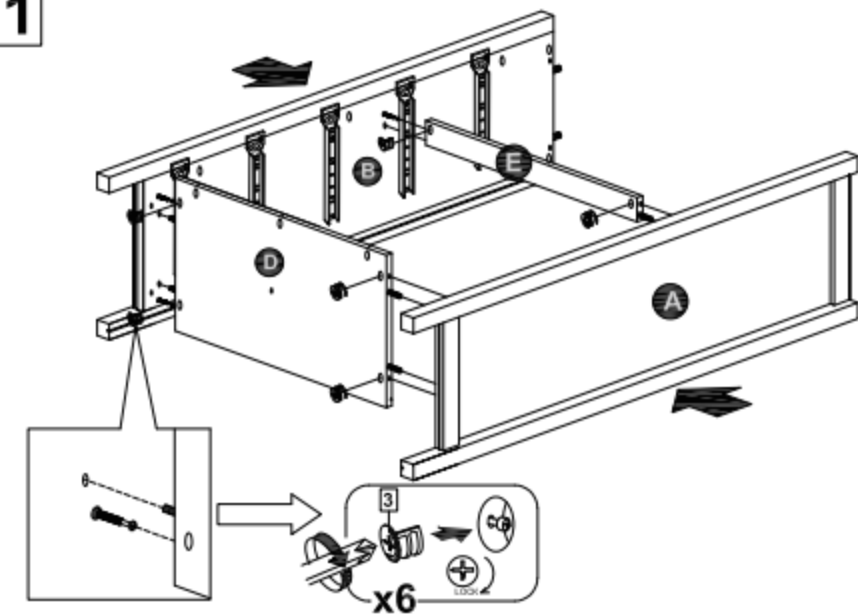

9

12

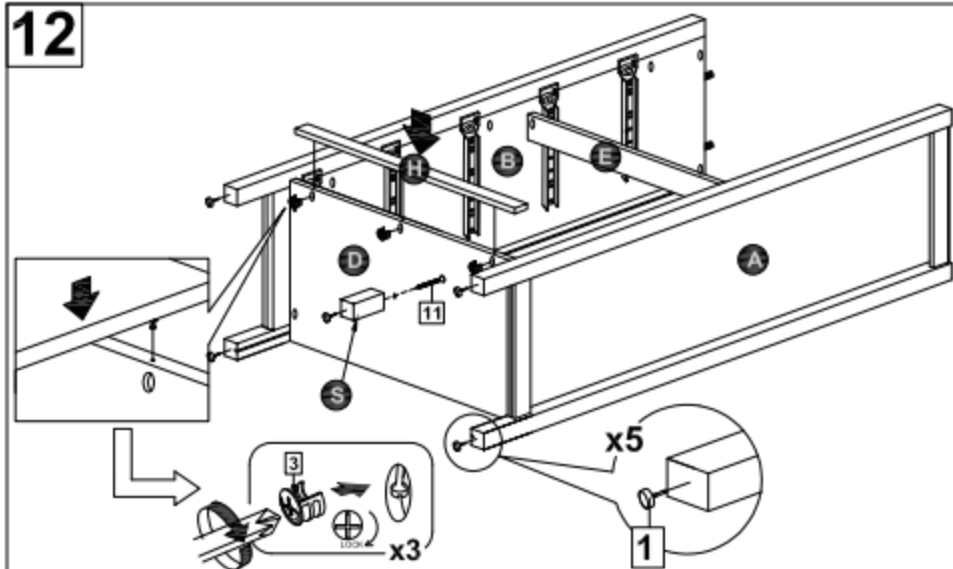

13

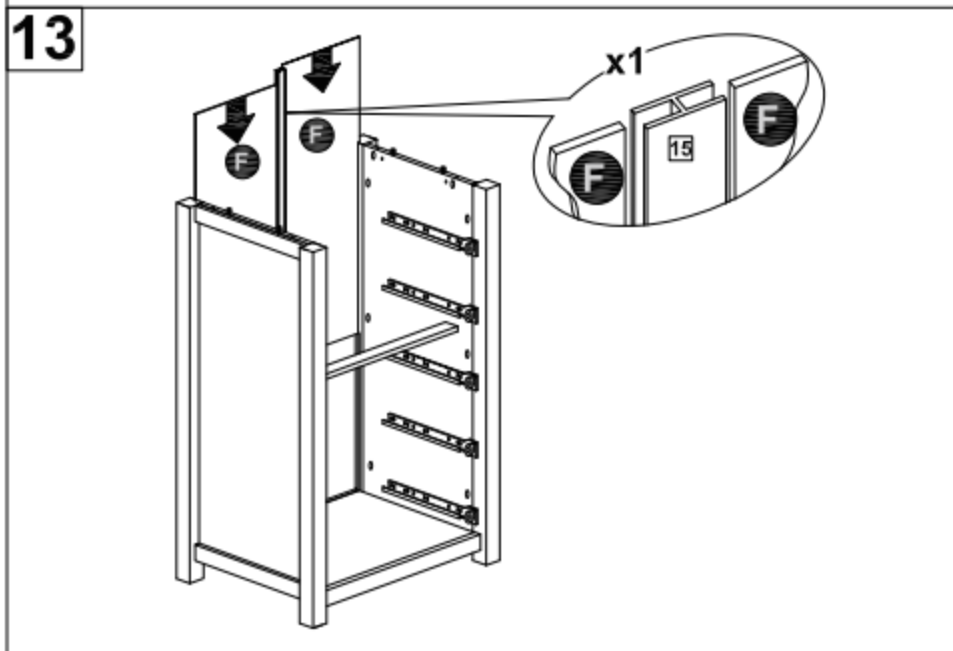

14

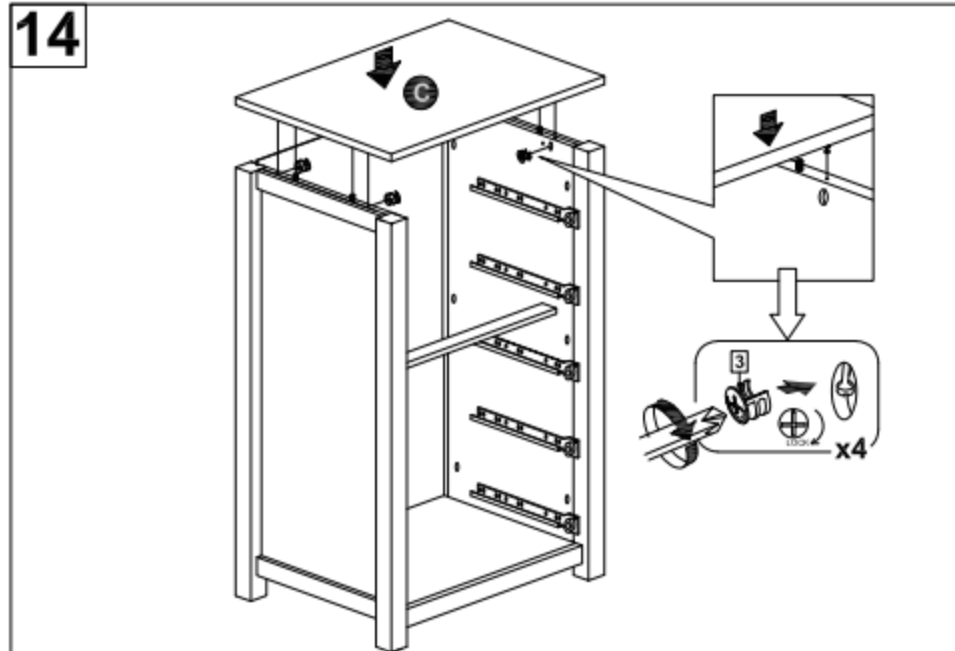

15

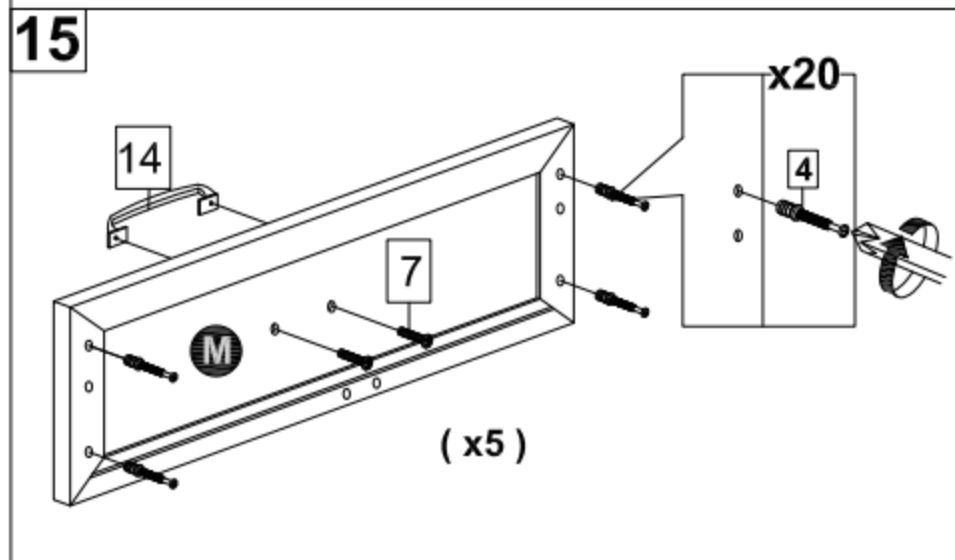

20

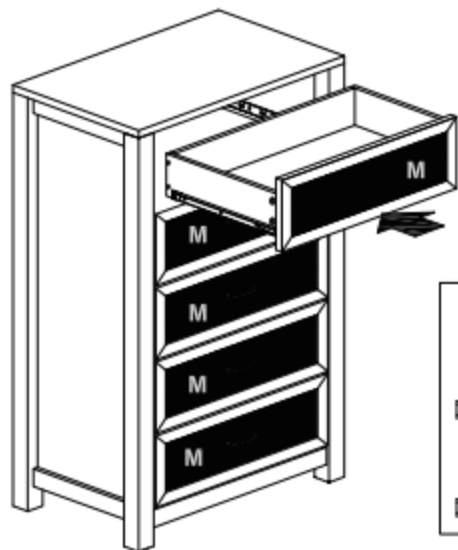

21

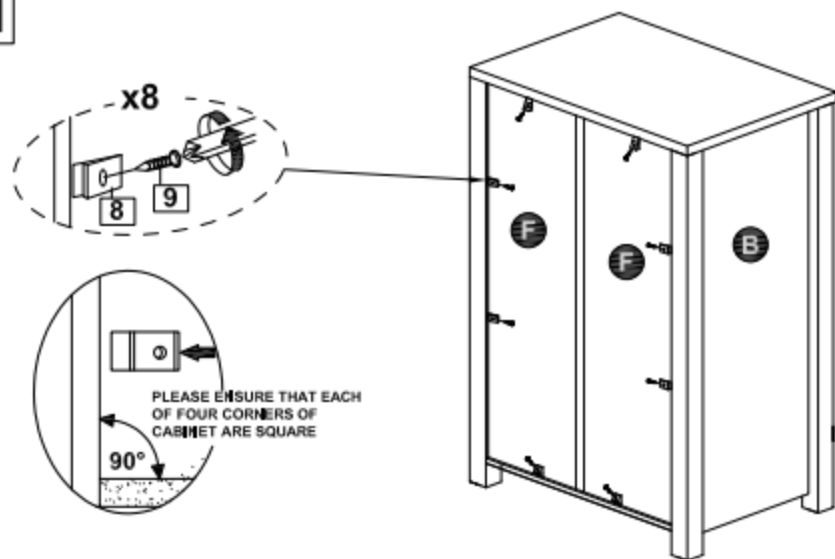

22

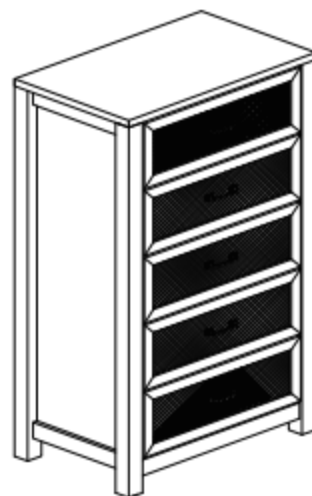

NOTE : THE MAXIMUM WEIGHT ON TOP PANEL UP TO 25KGS / 4KGS MAX WEIGHT FOR EACH DRAWER .

FITTING OF ANTI-TIP BRACKET

Befestigung der Kippschutzhalterung

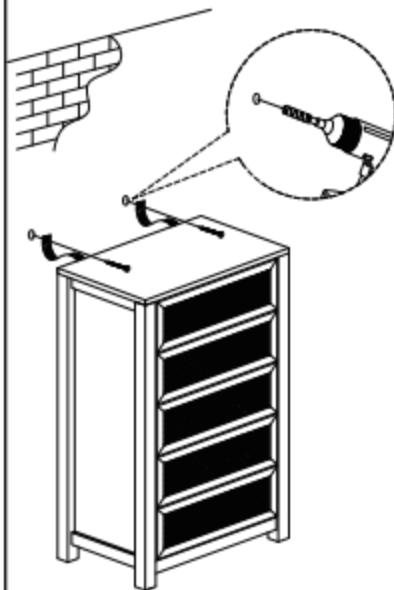
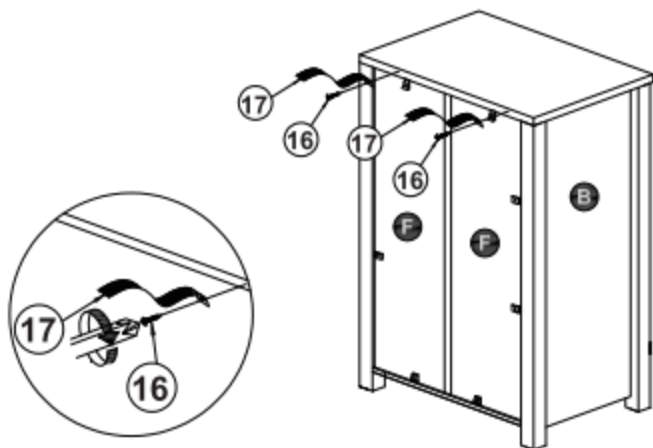

HARDWARE LIST



NOTE : Wall fixings are not supplied with this product as different wall materials require different types of fixing devices (such as Rawl plugs on brick work). You must use fixing devices suitable for the type of wall you intend to mount this product to. Please ensure that the head of any screw used has a diameter greater than the diameter of the mounting hole on the bracket and that the fixing is safe and secure before use.

The screw supplied is to fix the anti-tip strap to the cabinet.