

# ASSEMBLY INSTRUCTIONS

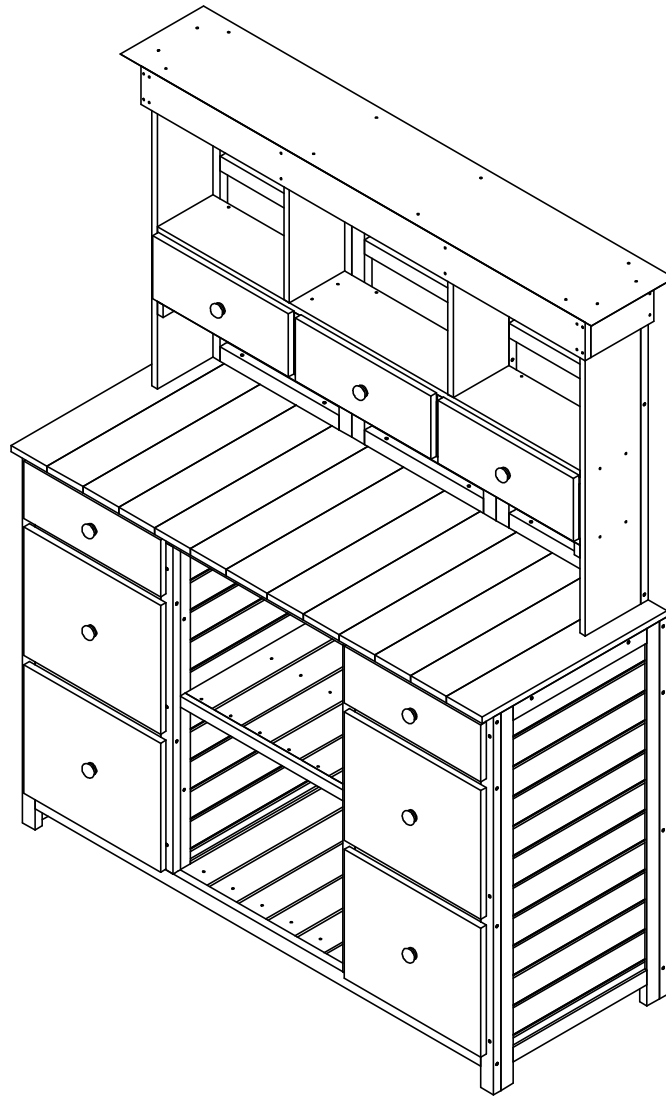





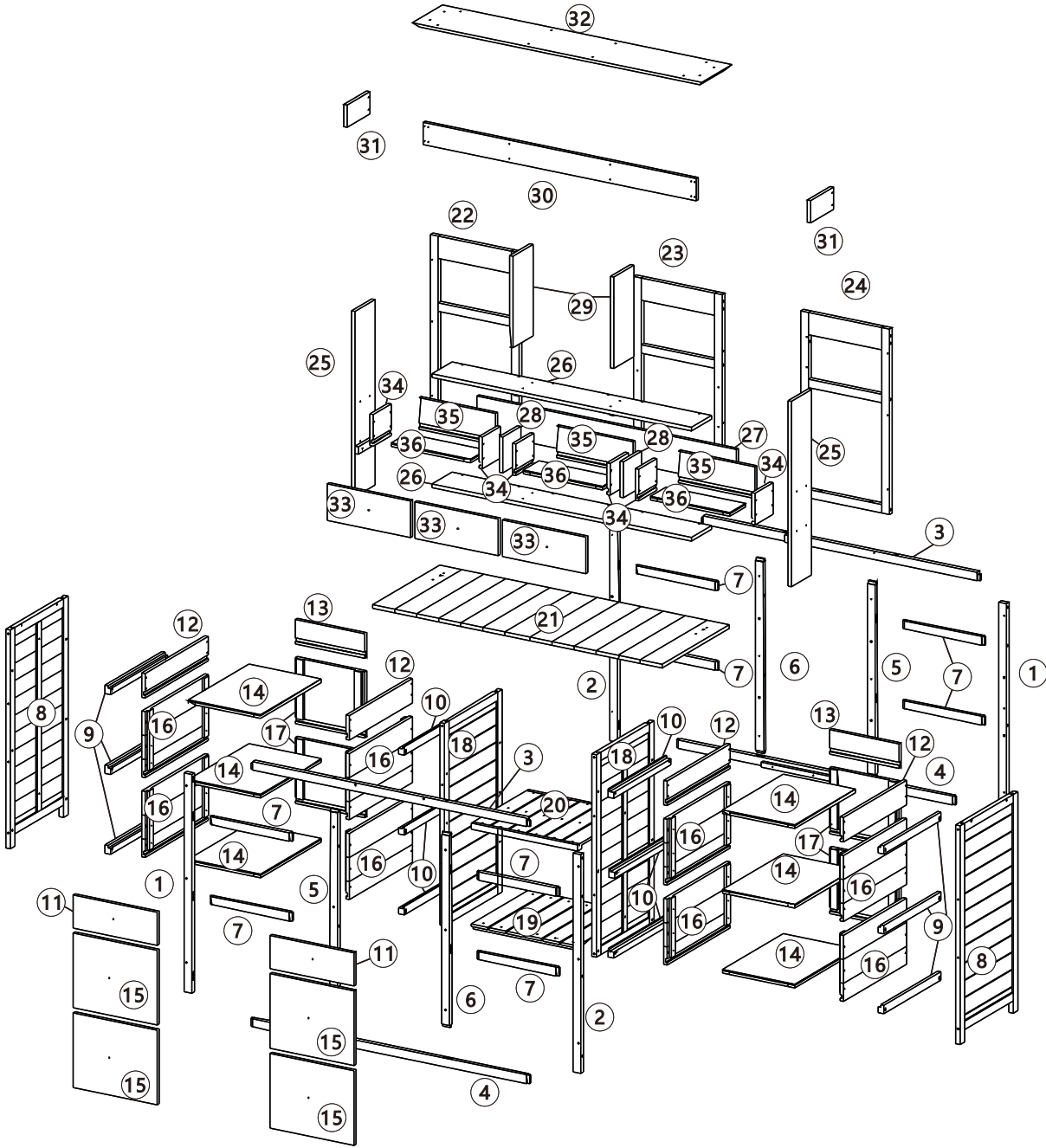

## IMPORTANT NOTE :

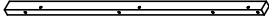
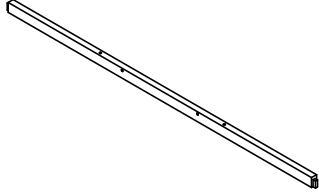
- ① PLACE ALL PARTS ON A CLEAN AND SMOOTH SURFACE SUCH AS A RUG OR CARPET TO AVOID THE PARTS FROM BEING SCRATCHED.
- ② BEFORE YOU BEGIN, KINDLY FOLLOW THE ASSEMBLY INSTRUCTIONS STEP BY STEP.
- ③ DO NOT TIGHTEN ALL SCREWS AND BOLTS UNTIL THIS ITEM IS FULLY SET-UP.

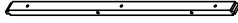
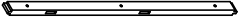
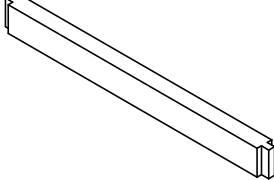
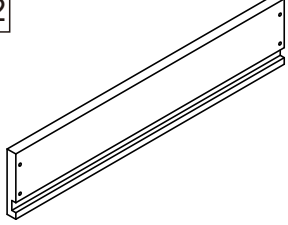
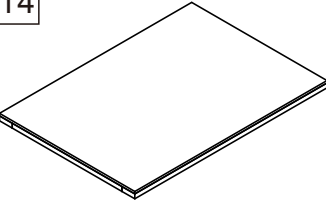
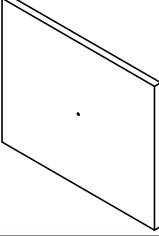
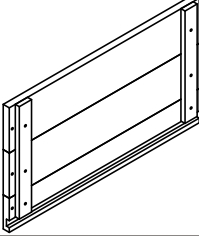
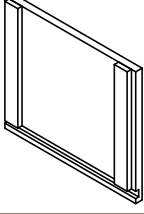
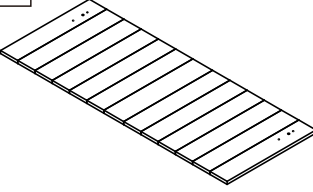
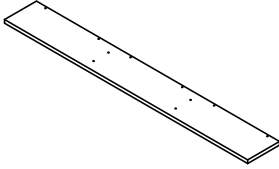
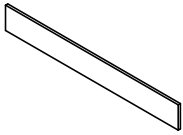
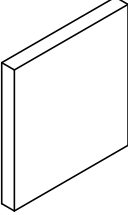
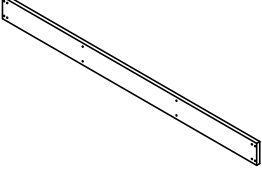
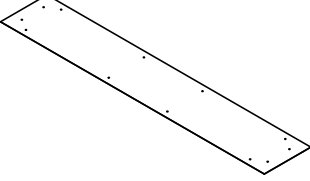



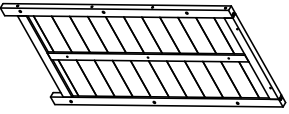
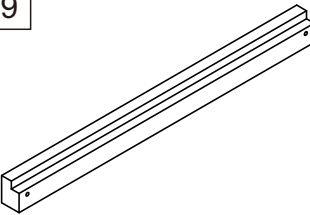
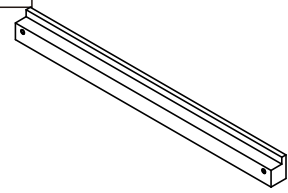
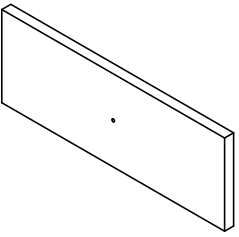
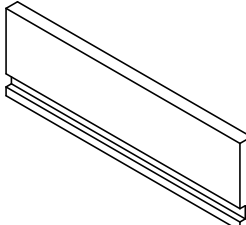
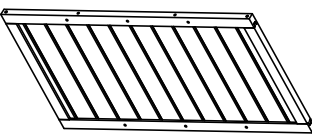
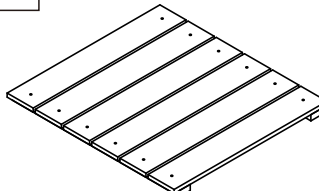
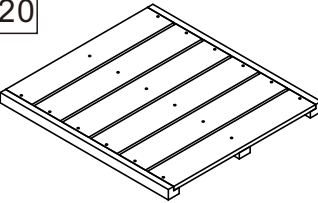
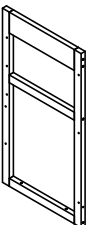
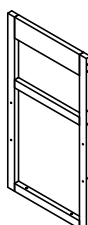
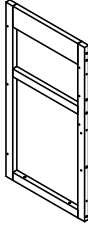

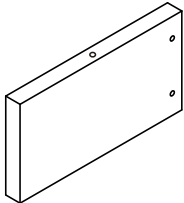
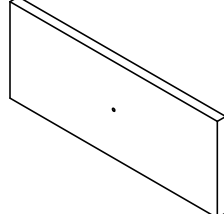
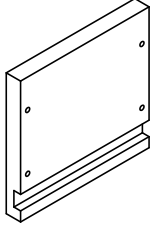
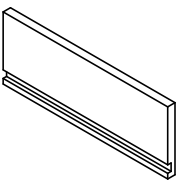
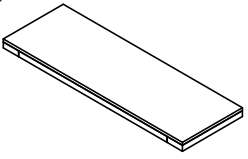



# Detail View



1	2	3	4
			
Left pillar of front&back frame 2pcs	Right pillar of front&back frame 2pcs	Upper slat of front&back frame 2pcs	Lower slat of front&back frame 2pcs
5	6	7	12
			
Middle left pillar of front&back frame 2pcs	Middle right pillar of front&back frame 2pcs	Horizontal slat of front frame 8pcs	Side panel of drawer ①4pcs
14	15	16	17
			
Bottom of drawer ①&②6pcs	Front of drawer ② 4pcs	Side panel of drawer ②8pcs	Back of drawer ②4pcs
21	26	27	28
			
Table top 1pc	Support of drawer ③2pcs	Back panel of drawer ③1pc	Divider of drawer ③2pcs
30	32		
			
Upper front 1pc	Top 1pc	Hardware kit	

<p>8</p> 	<p>9</p> 	<p>10</p> 	<p>11</p> 
<p>Side panel of frame 2pc</p>	<p>Support①of drawer①&amp;②6pcs</p>	<p>Support②of drawer①&amp;②6pcs</p>	<p>Front of drawer① 2pcs</p>
<p>13</p> 	<p>18</p> 	<p>19</p> 	<p>20</p> 
<p>Back of drawer①2pcs</p>	<p>Under side panel 2pc</p>	<p>Shelves①1pc</p>	<p>Shelves②1pc</p>
<p>22</p> 	<p>23</p> 	<p>24</p> 	<p>25</p> 
<p>Left part of back panel 1pc</p>	<p>Middle part of back panel 1pc</p>	<p>Right part of back panel 1pc</p>	<p>Side parts of storage rack 2pcs</p>
<p>29</p> 	<p>31</p> 	<p>33</p> 	<p>34</p> 
<p>Divider of storage rack 2pcs</p>	<p>Upper side panel 2pc</p>	<p>Front of drawer③ 3pcs</p>	<p>Side panel of drawer③6pcs</p>
<p>35</p> 	<p>36</p> 		
<p>Back panel of drawer③3pcs</p>	<p>Bottom of drawer③ 3pcs</p>		

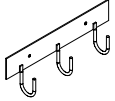
Hardware List

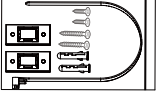
<p>A</p>  <p>3.5*40</p> <p>Ph zinc screws-56+1pcs</p>	<p>B</p>  <p>3.5*60</p> <p>Ph zinc screws-44+1pcs</p>	<p>C</p>  <p>3.0*38</p> <p>Ph zinc screws-32+1pcs</p>	<p>D</p>  <p>3.0*30</p> <p>Ph zinc screws-136+1pcs</p>
<p>E</p>  <p>3.0*18</p> <p>Black screws-2+1pcs</p>	<p>F</p>  <p>M4*30</p> <p>Ph zinc bolt-9+1pcs</p>	<p>G</p>  <p>Door knob-9pcs</p>	<p>H</p>  <p>Dowel-56pcs</p>
<p>I</p>  <p>Black Hook-1pc</p>	<p>J</p>  <p>LAMINATED NAIL 4pcs</p>	<p>Anti-topple over sets-2pcs</p> 	

ASSEMBLY TOOLS REQUIRED( NOT INCLUDED)



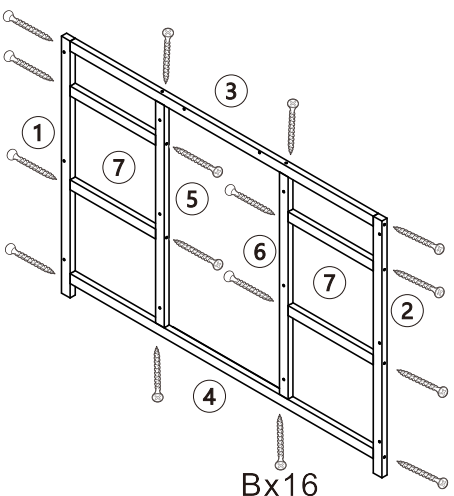

PLEASE BE CAREFUL DO NOT DAMAGE THE HOLE POSITION WHEN YOU USE POWERTOOLS !



Repeat this step two times

step 1

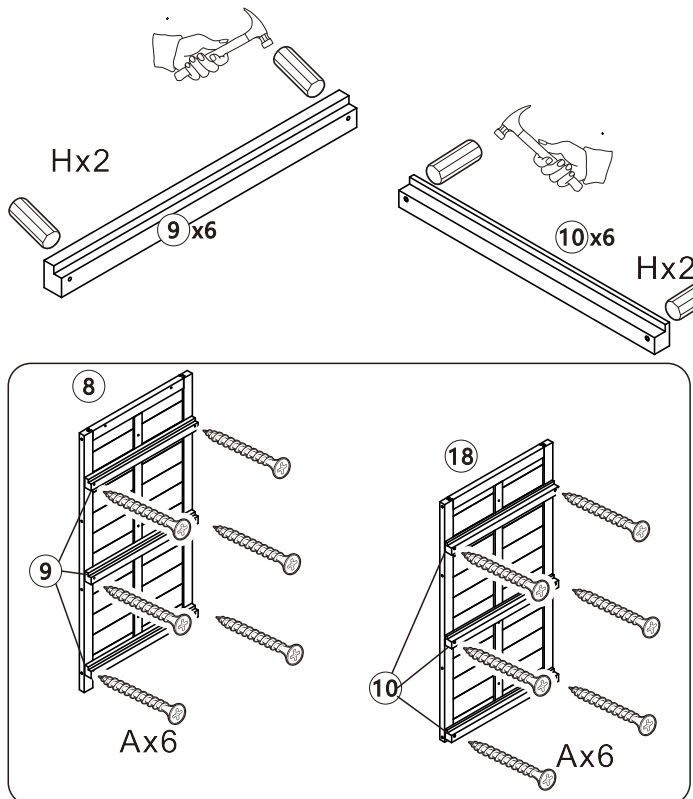
①x2 ②x2 ③x2 ④x2 ⑤x2 ⑥x2 ⑦x8  
Bx32



x2

step 2

⑨x6 ⑩x6 ⑧x2 ⑱x2  
Ax24 Hx24

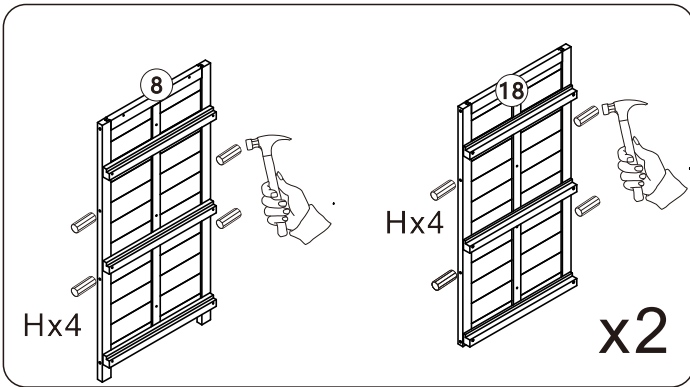

Hx4

Hx4

x2

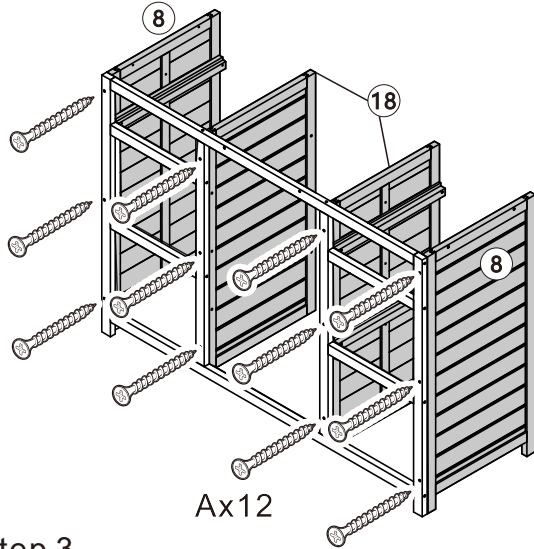

Ax12

step 3

Ax12 Hx16

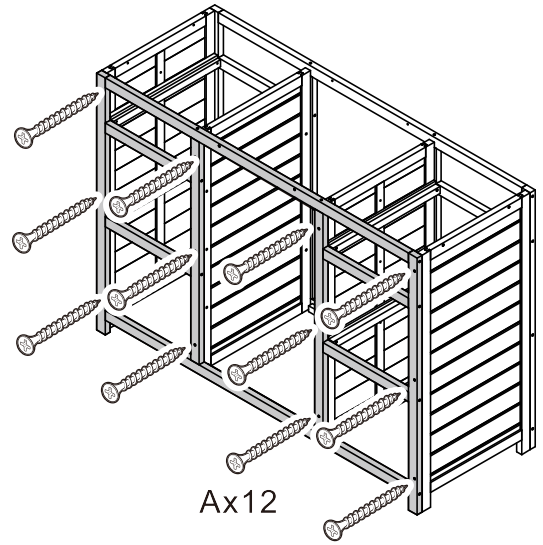

Ax12

step 4

Ax12

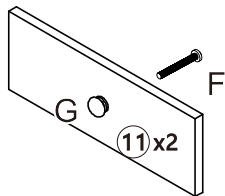

11x2

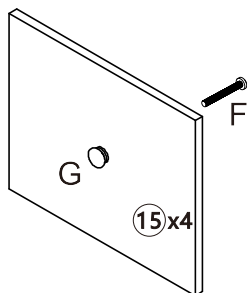

15x4

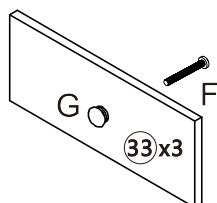

33x3

step 5

11x2 15x4 33x3

Fx9 Gx9

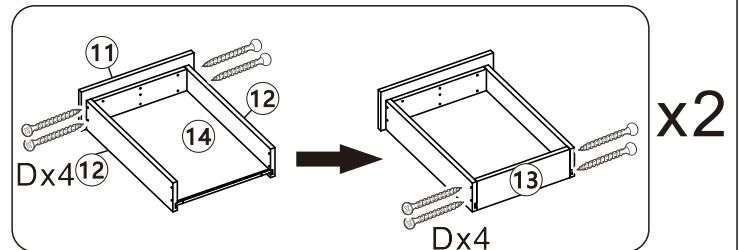

Dx4

Dx4

x2

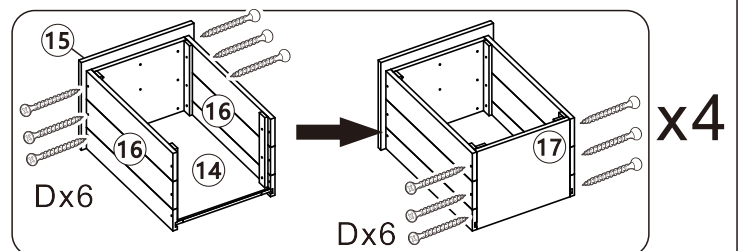

Dx6

Dx6

x4

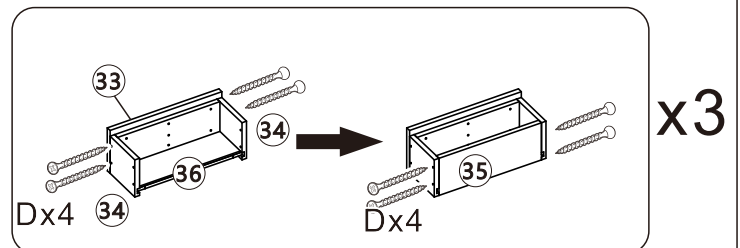

Dx4

Dx4

x3

step 6

11x2 12x4 13x2 14x6 15x4  
16x8 17x4 34x6 33x3 35x3 36x3

Dx88

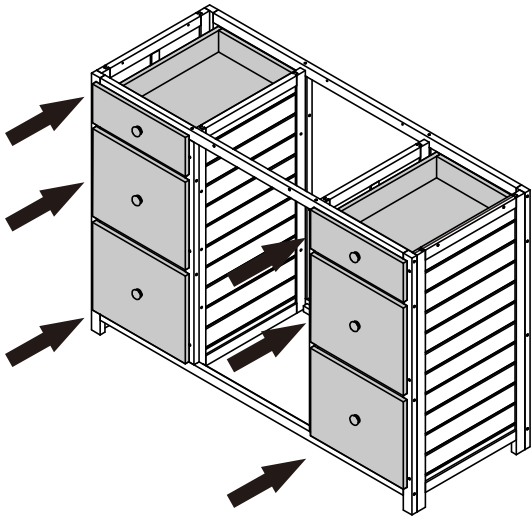

step 7

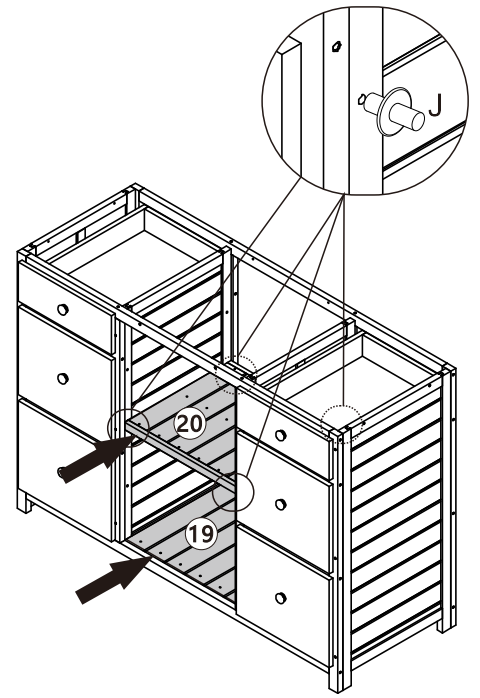

step 8

19x1 20x1

Jx4

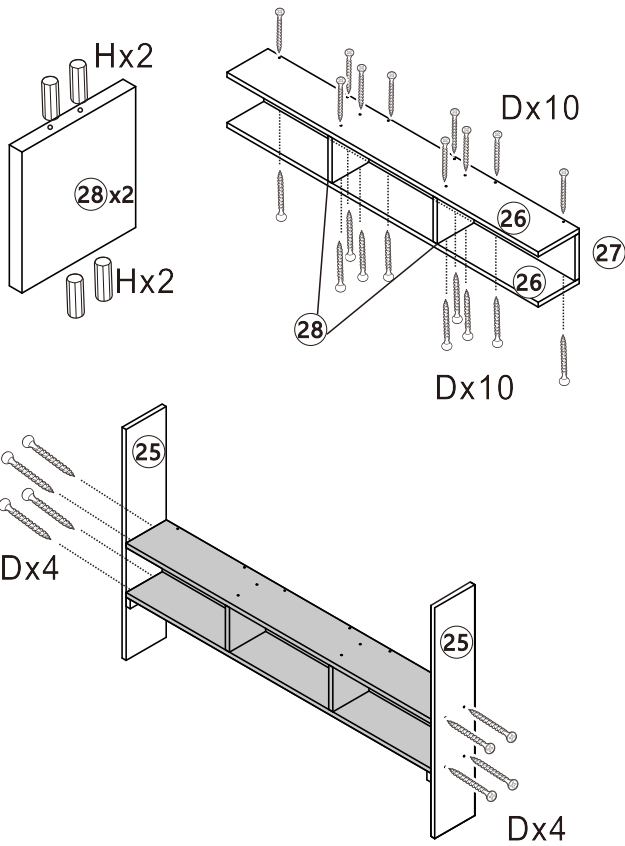

step 9

25x2 26x2 27x1 28x2

Dx28 Hx8

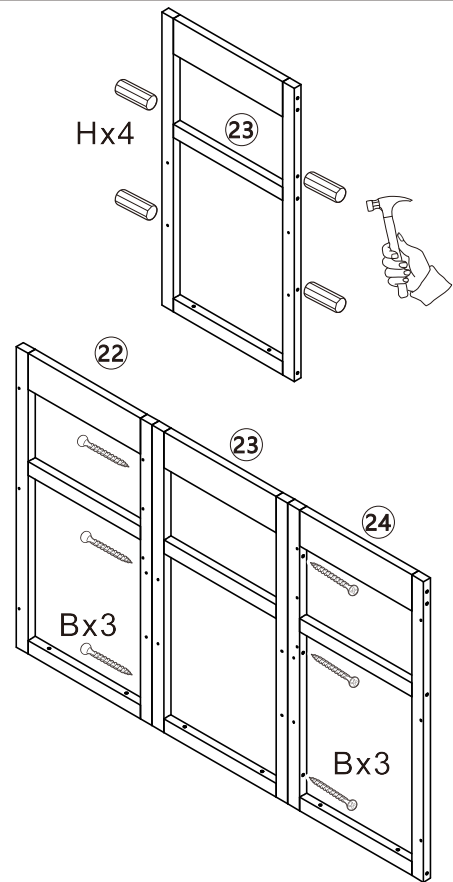

step 10

22x1 23x1 24x1

Bx6 Hx4

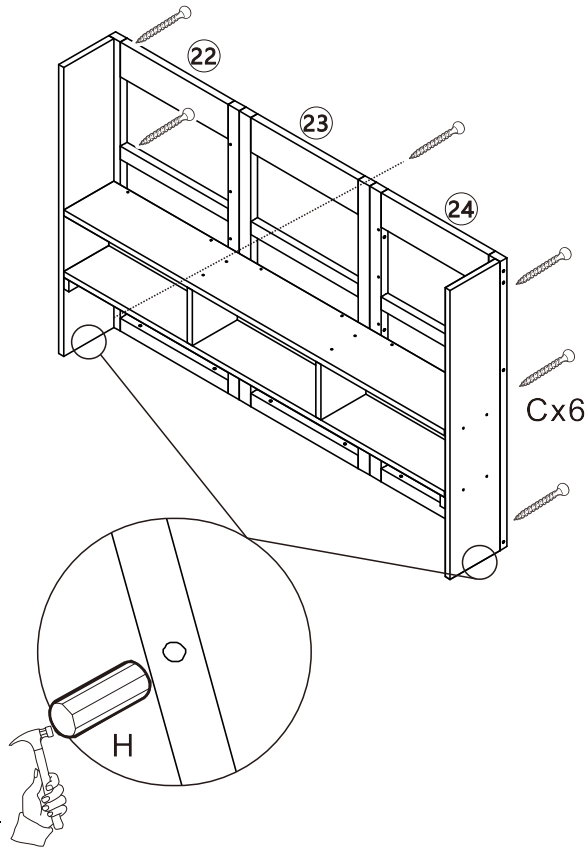

step 11

Cx6 Hx2

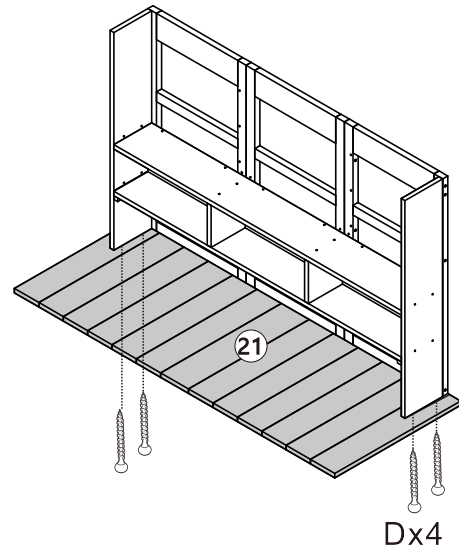

step 12

21x1  
Dx4

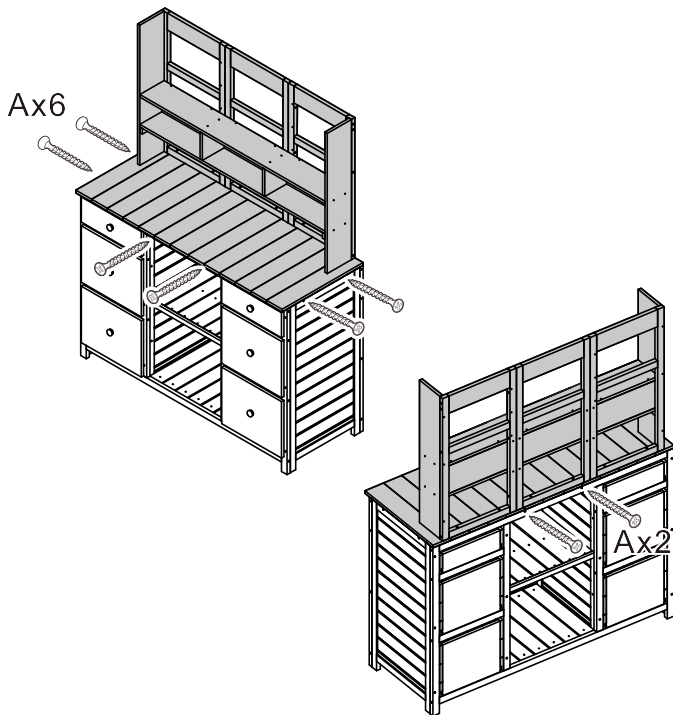

step 13

Ax8

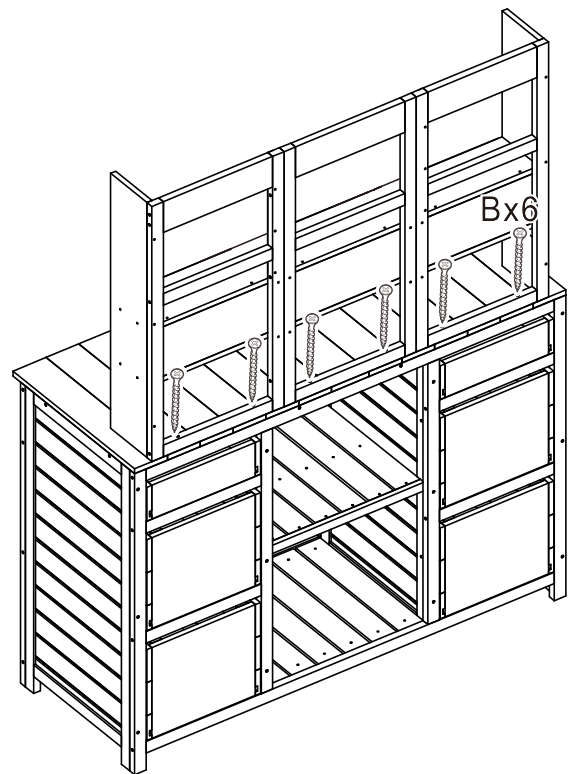

step 14

Bx6

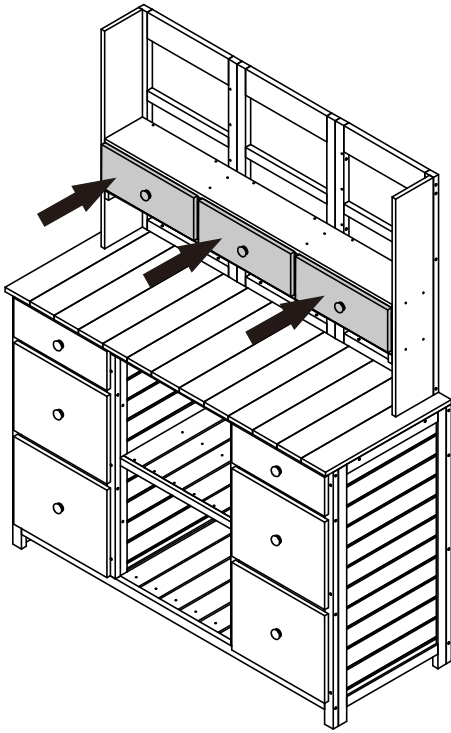

step 15

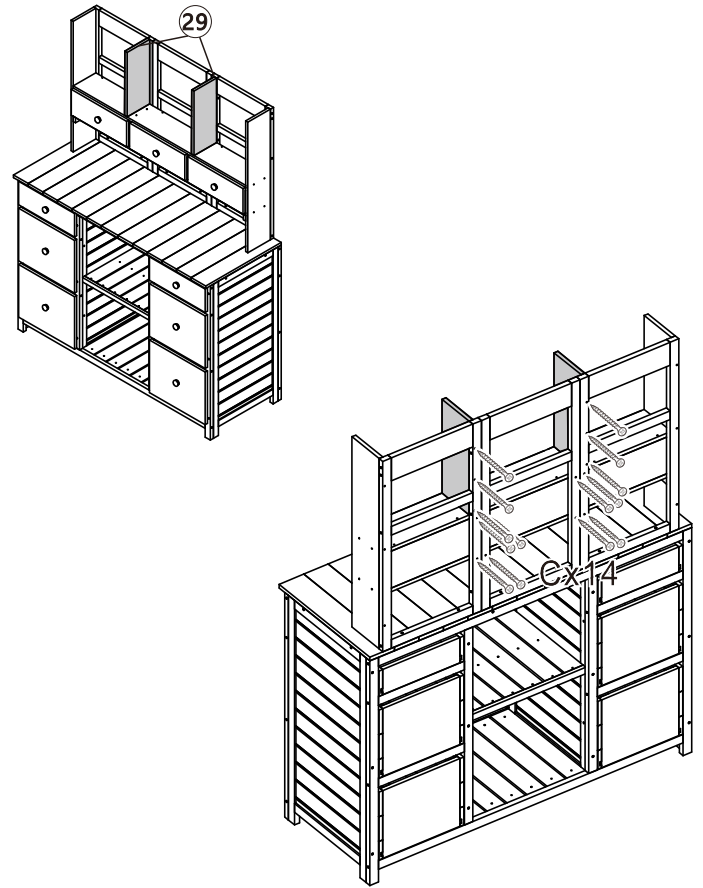

step 16

29x2

Cx14

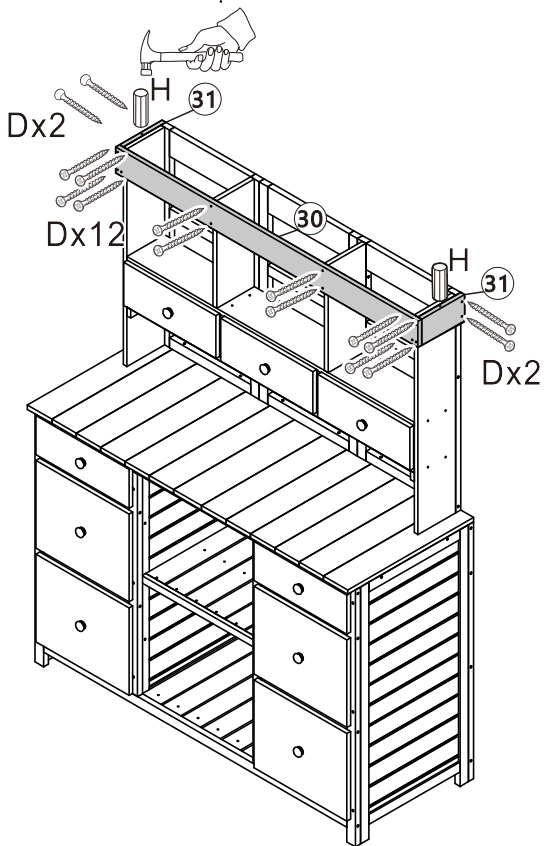

step 17

30x1 31x2  
Dx16 Hx2

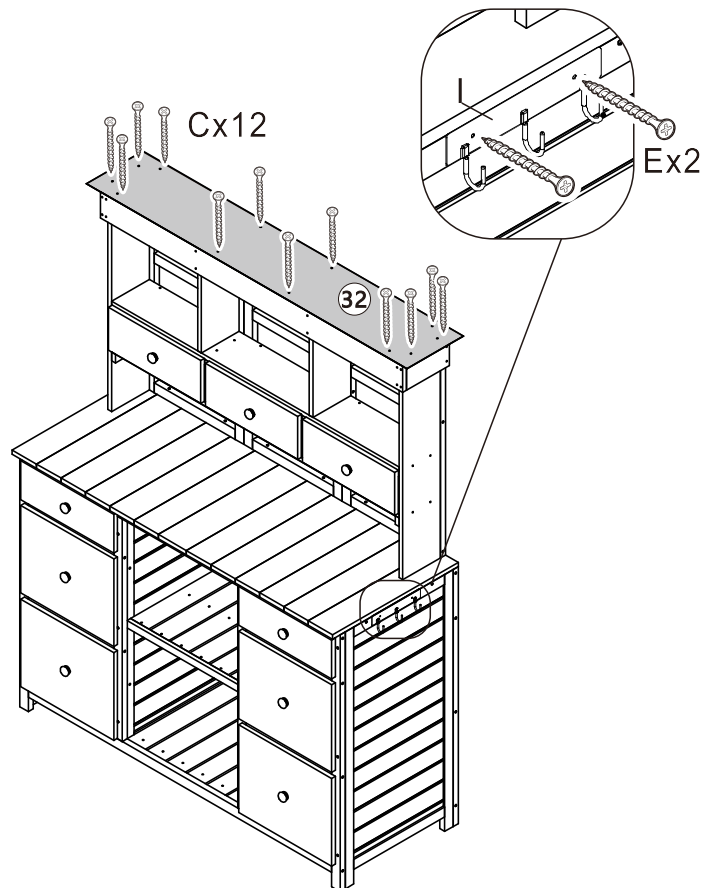

step 18

32x1

Cx12 Ex2 lx1

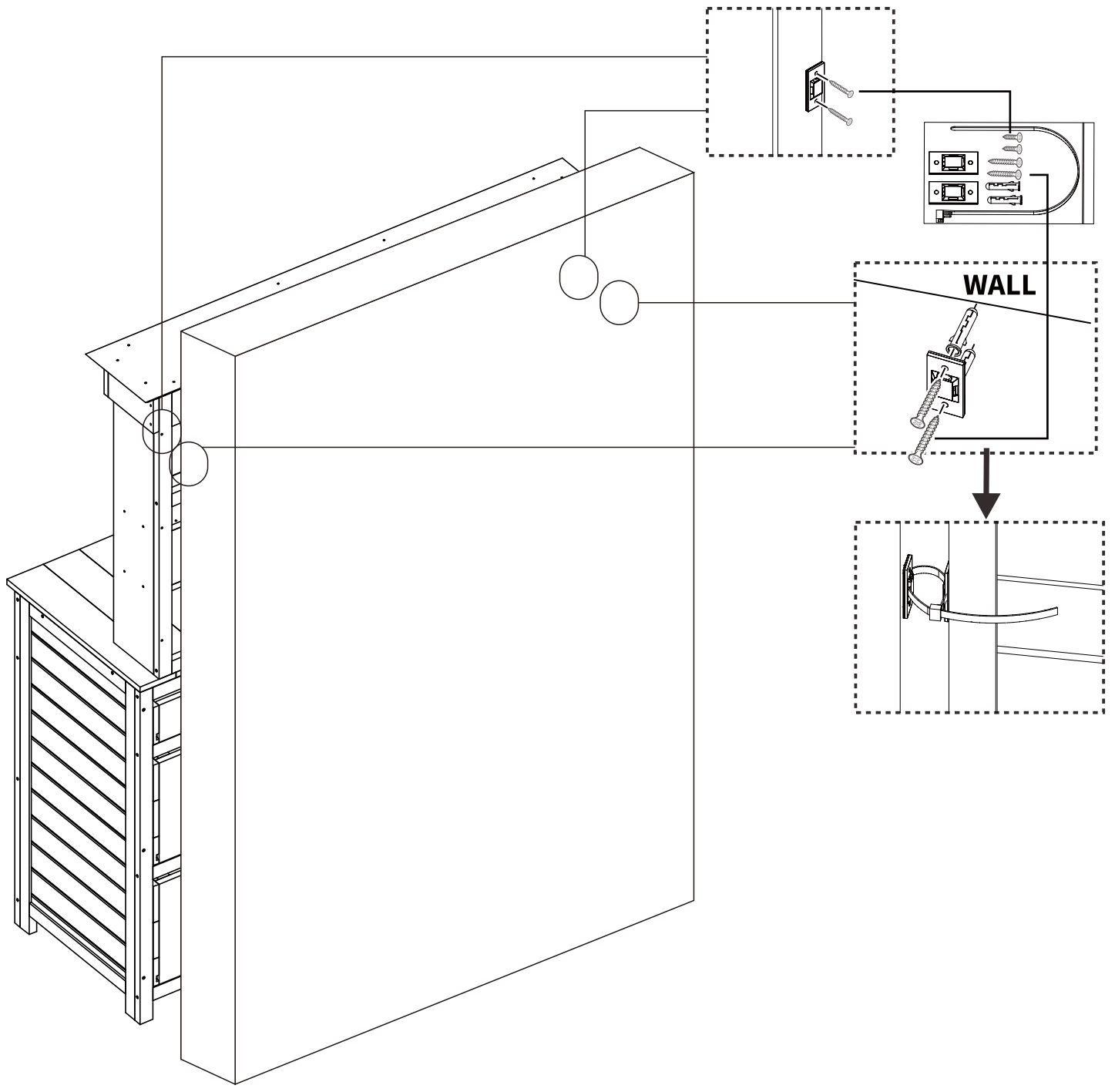

step 19

