

# EGG CHAIR

## ASSEMBLY GUIDE

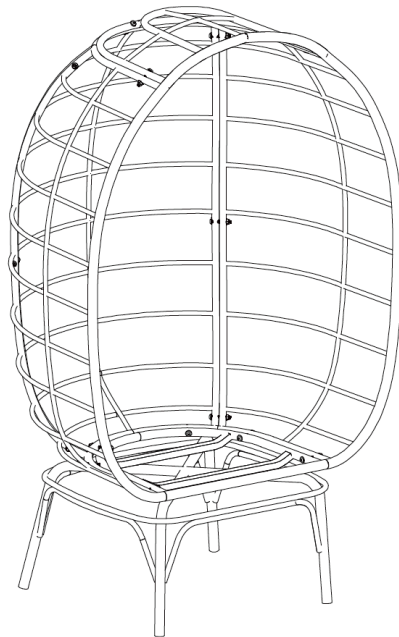

**Important - Please read these instructions fully before starting assembly**



**SAFETY AND  
CARE ADVICE**



**NO POWER TOOLS**

### **SAFETY AND CARE ADVICE**

- Check you have all the components and tools listed.
- Remove all fittings from the plastic bags and separate them into their groups.
- We do not recommend the use of power drills/drivers for inserting screws, as this could damage the unit. Only use hand screwdrivers and Allen keys.
- Keep children and animals away from the work area, small parts could cause choking if swallowed.
- Make sure you have enough space to layout the parts before starting.
- Assemble the item as close to its final position (in the same room) as possible.
- Do not overtighten the nuts to avoid causing damage to the threads.
- Only clean using a damp cloth and mild detergent, do not use bleach or abrasive cleaners.
- From time to time check that there are no loose screws on this unit
- This product should not be discarded with household waste. Take to your local authority waste disposal centre

## IMPORTANT INFORMATION



45 MINUTE  
BUILD













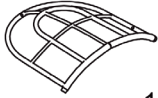
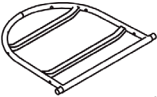



TWO  
PERSON

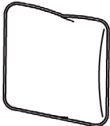

MAXIMUM  
CAPACITY 100Kg

PLEASE CHECK CAREFULLY AND MAKE SURE YOU HAVE ALL FITTINGS AND TOOLS LISTED BELOW BEFORE YOU START.

<p><b>A</b></p>  <p>1PC</p>	<p><b>B</b></p>  <p>1PC</p>	<p><b>C</b></p>  <p>1PC</p>	<p><b>D</b></p>  <p>1PC</p>
<p><b>E</b></p>  <p>1PC</p>	<p><b>F</b></p>  <p>1PC</p>	<p><b>G</b></p>  <p>M6*35mm 4PCS</p>	<p><b>H</b></p>  <p>M6*50mm 6PCS</p>
<p><b>I</b></p>  <p>M6*55mm 9PCS</p>	<p><b>J</b></p>  <p>34PCS</p>	<p><b>K</b></p>  <p>9PCS</p>	<p><b>L</b></p>  <p>6PCS</p>
<p><b>M</b></p>  <p>1PC</p>	<p><b>N</b></p>  <p>1PC</p>	<p><b>O</b></p>  <p>1PC</p>	<p><b>P</b></p>  <p>2PCS</p>
<p><b>Q</b></p>  <p>1PC</p>			

**NOTE:** The quantities above are the correct amount to complete the assembly. In some cases more fittings may be supplied than are required.

Construct your furniture on a nice flat, soft surface like a carpet, rug, or the lawn, to avoid any bumps and scratches. First, lay out all your pieces and check you have all the items listed on the inventory.

## STEP 1

Don't fully tighten any of the bolts until all of the components are in place.

Connect the side pieces [A] and [B] to the centre piece [C] using 6x bolts [H] and 12x washers [J] with 6x nuts [K]. Double check you're using the correct bolts here. Thread the bolts from the centre panel facing outwards, and secure with the washer and nuts from the side-panel side of the holes, as illustrated in the zoomed-in segment.

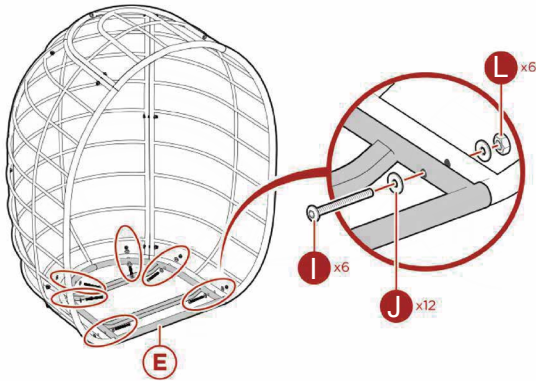
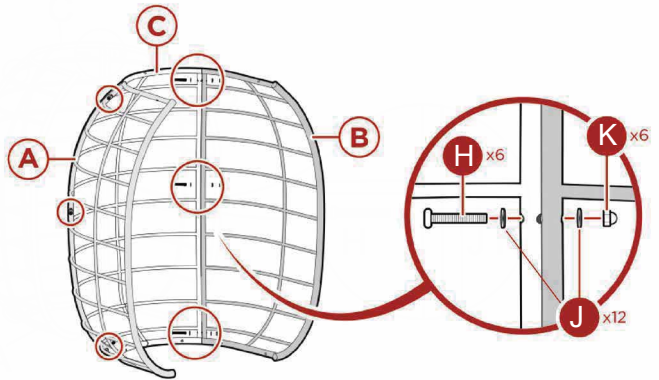

## STEP 2

Connect the bottom piece [E] using 6x bolts [I] and 6x washers [J] with 6x nuts [L] and 6x washers [J]. Thread the bolts through the bottom piece, facing outwards, and secure with washers and nuts on the other side of the holes, as illustrated in the zoomed-in segment.

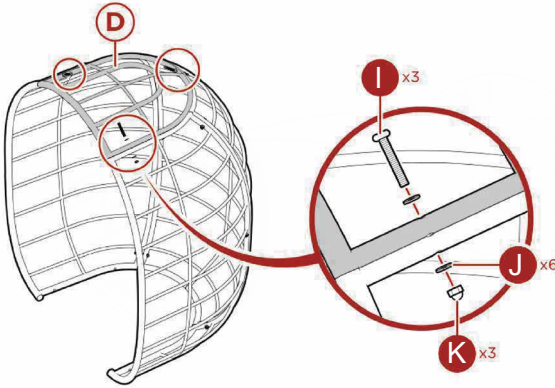

### STEP 3

Attach the top piece [D] using 3x bolts [I] and 3x washers [J] with 3x nuts [K]. Check you're using the correct bolts here. Thread the bolts through from the top piece facing in towards the side/back pieces, and secure with washers and nuts on the other side of the holes, as illustrated in the zoomed-in segment.

### STEP 4

Carefully lay your seat face-down on the flat surface to attach the legs piece [F]. Use 4x bolts [G] and washers [J]. Thread bolts through from outside of piece [F] towards the inside of the seat.

Once everything is in place, go ahead and tighten all of the bolts, but take care not to over-tighten.

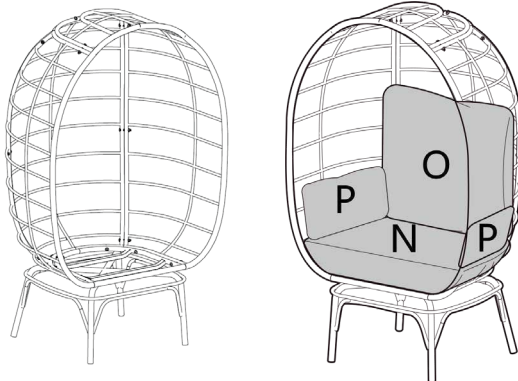
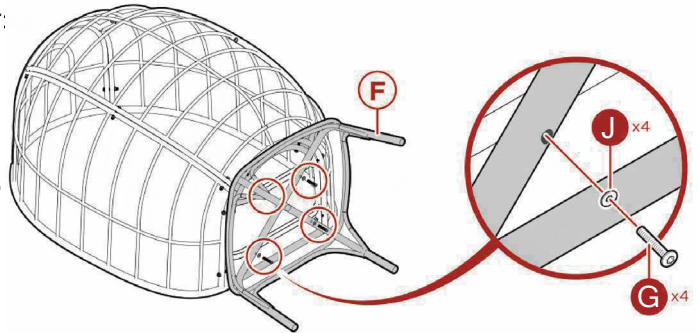

### STEP 5

Carefully, and with help, stand your egg chair on its feet and check stability. Add cushions [N, O and 2x P]. Your egg chair is now complete!