

---

## TWIN FULL BUNK BED



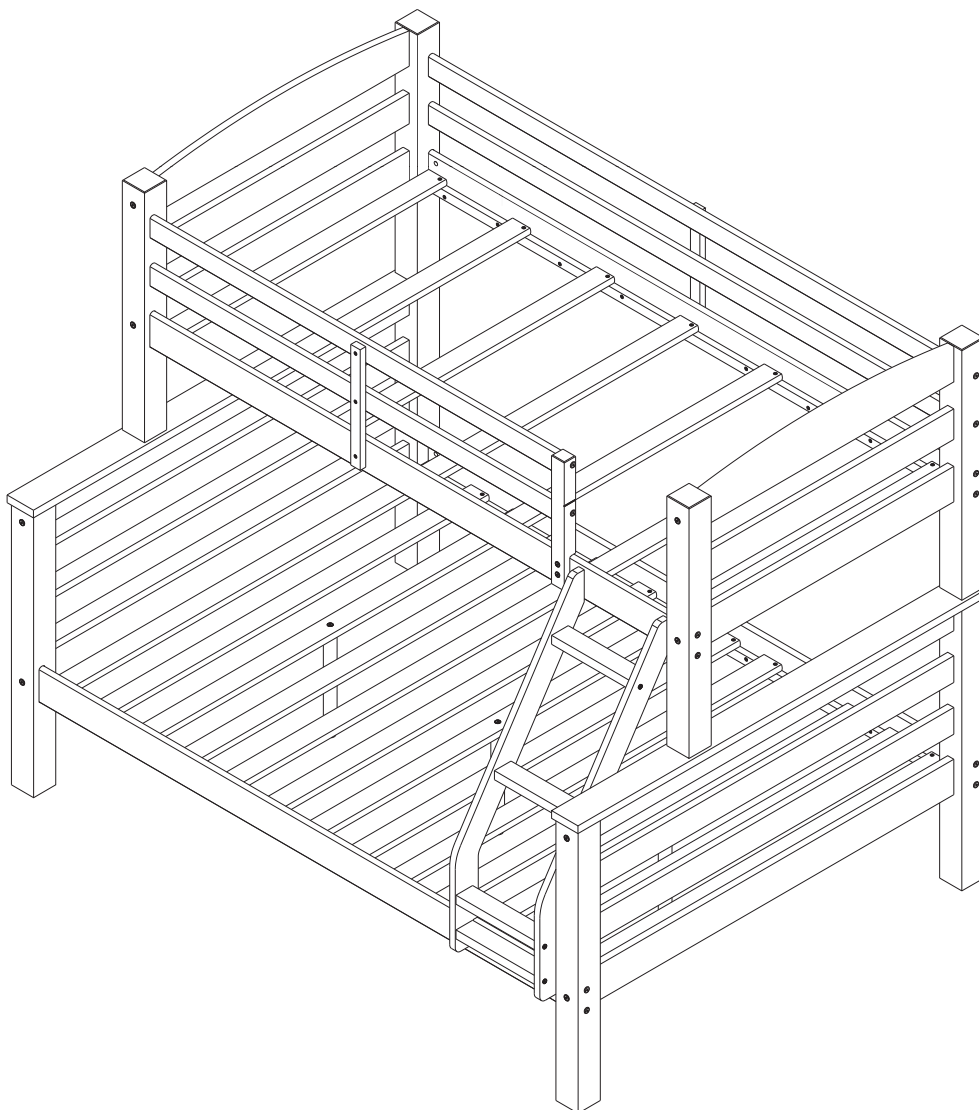

This bed is designed to use only a mattress which is 74"-75" long and 37-1/2" - 38-1/2" wide on upper bunk and Full mattress which is 74"-75" long and 53"-54" wide on lower bunk.

Ensure thickness of mattress does not exceed 8" and surface of mattress is at least 5" below upper edge of guardrail

Replacement parts, including additional guardrails, may be obtained from Powell Company

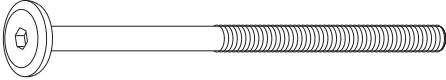
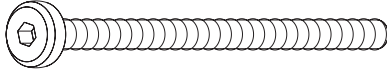
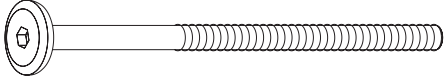

## HARDWARE LIST

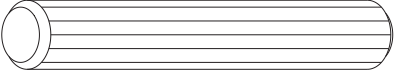
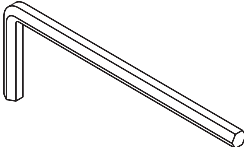
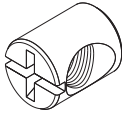
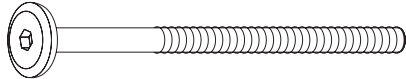
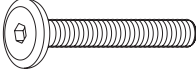
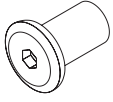
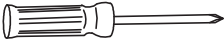

<p><b>1</b></p>  <p>Φ 1/4" x 130mm</p>	<p><b>2</b></p>  <p>Φ 6.5mm x 48mm</p>	
<p>JOINT CONNECTOR (4mm HEX HEAD) 16 PCS</p>	<p>WOOD JOINT CONNECTOR (4mm HEX HEAD) 20 PCS</p>	
<p><b>3</b></p>  <p>Φ 6.5mm x 120mm</p>	<p><b>4</b></p>  <p>Φ 4mm x 35mm</p>	
<p>WOOD JOINT CONNECTOR (4mm HEX HEAD) 22 PCS</p>	<p>FLAT HEAD SCREW 40 PCS</p>	
<p><b>5</b></p>  <p>Φ 10mm x 100mm</p>	<p><b>6</b></p>  <p>Φ 4mm x 30mm</p>	
<p>METAL DOWEL 4 PCS</p>	<p>FLAT HEAD SCREW 6 PCS</p>	
<p><b>7</b></p>  <p>Φ 10mm x 50mm</p>	<p><b>8</b></p> 	
<p>WOOD DOWEL 76 PCS</p>	<p>ALLEN KEY 1 PC</p>	
<p><b>9</b></p>  <p>Φ 11.8mm x 15mm</p>	<p><b>10</b></p>  <p>Φ 6.5mm x 80mm</p>	
<p>BARREL NUT 16 PCS</p>	<p>WOOD JOINT CONNECTOR (4mm HEX HEAD) 2 PCS</p>	
<p><b>11</b></p>  <p>Φ 1/4" x 32mm</p>	<p><b>12</b></p>  <p>Φ 9mm x 17mm</p>	
<p>JOINT CONNECTOR (4mm HEX HEAD) 5 PCS</p>	<p>HEX CAP 2 PCS</p>	<p>Screwdriver (not provided)</p>

\*\*\* **Note:** Find the label of "Hardware Enclosed" on one of the carton corner then follow the red ribbon to get the hardware bag.

\*\*\* **Remarque:** Repérez l'étiquette «Quincaillerie Incluse» sur le coin de la boîte, puis suivez le ruban rouge pour récupérer le sac contenant la quincaillerie.

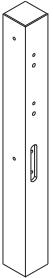
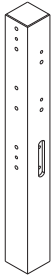

\*\*\* **Nota:** Busque la etiqueta "Ferretería Incluida" en una de las esquinas de la caja, luego siga la cinta roja para recuperar la bolsa que contiene la tornillería.

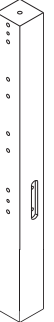
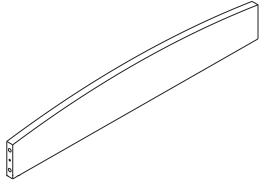
# PARTS LIST

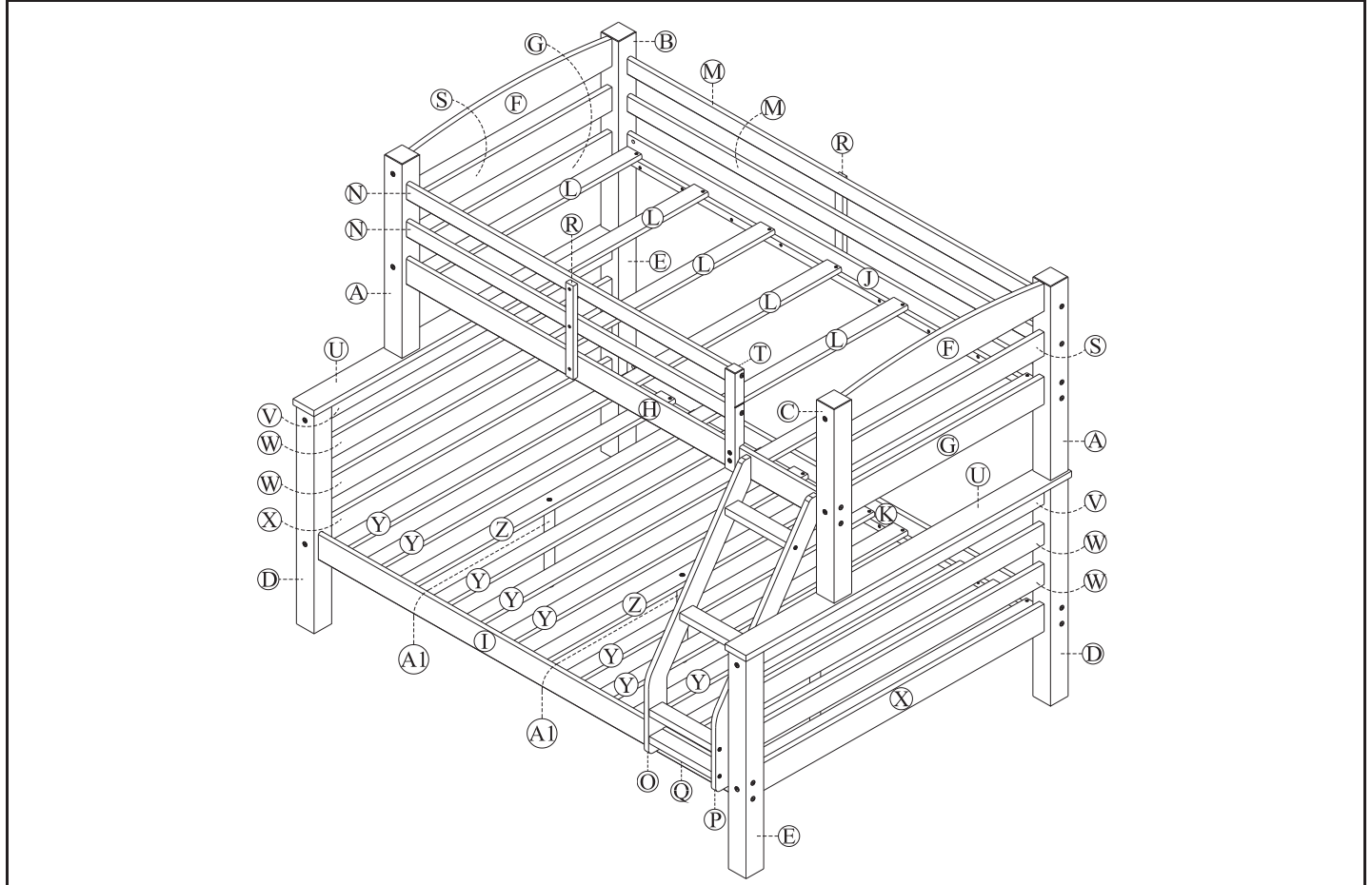



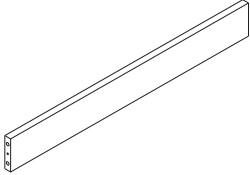
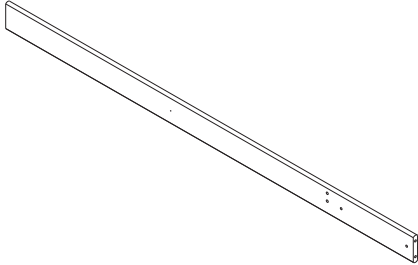
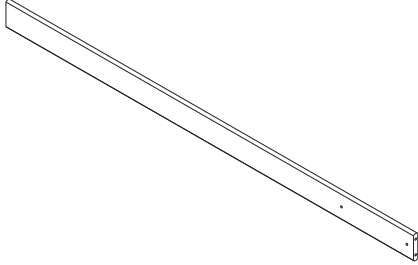
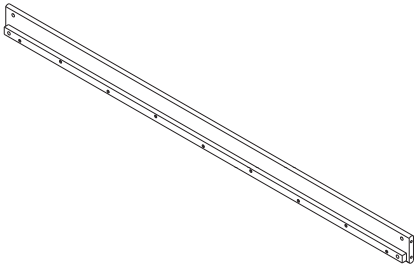
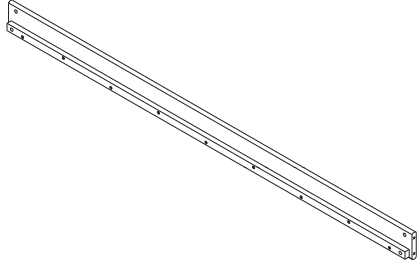
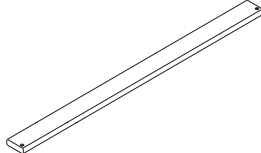
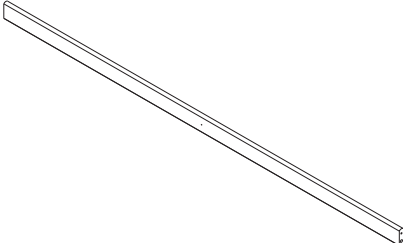
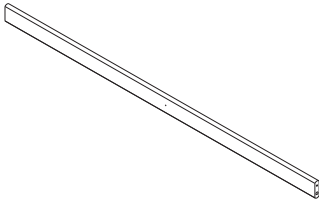
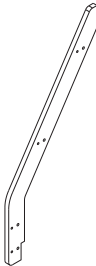
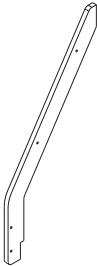
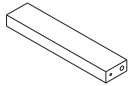

<p><b>A</b></p> 	<p><b>B</b></p> 	<p><b>C</b></p> 
<p>TOP POST 2 PCS</p>	<p>TOP POST 1 PC</p>	<p>TOP POST 1 PC</p>
<p><b>D</b></p> 	<p><b>E</b></p> 	<p><b>F</b></p> 
<p>BOTTOM POST 2 PCS</p>	<p>BOTTOM POST 2 PCS</p>	<p>TOP HEADBOARD TOP CROSS 2 PCS</p>

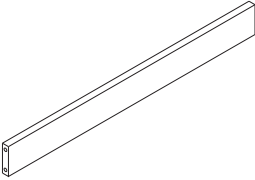

# PARTS LIST

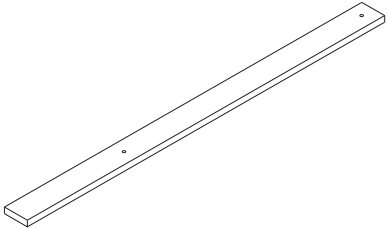
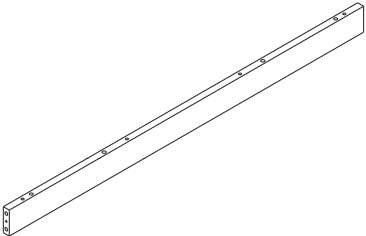
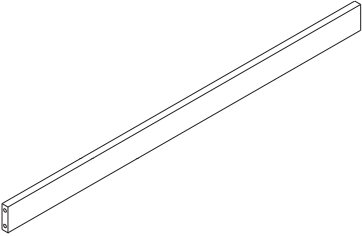
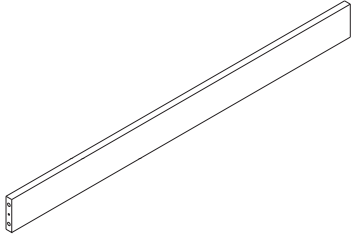
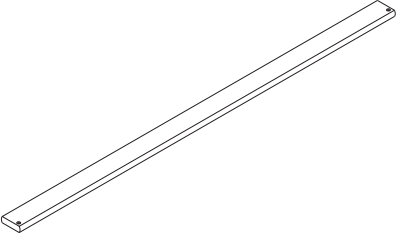
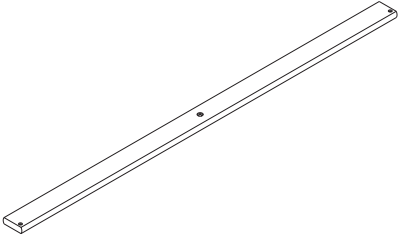
<p><b>G</b></p> 	<p><b>H</b></p> 	<p><b>I</b></p> 
<p>TOP HEADBOARD BOTTOM CROSS 2 PCS</p>	<p>TOP FRONT SIDE RAIL 1 PC</p>	<p>BOTTOM FRONT SIDE RAIL 1 PC</p>
<p><b>J</b></p> 	<p><b>K</b></p> 	<p><b>L</b></p> 
<p>TOP BACK SIDE RAIL 1 PC</p>	<p>BOTTOM BACK SIDE RAIL 1 PC</p>	<p>TOP SLAT 7 PCS</p>
<p><b>M</b></p> 	<p><b>N</b></p> 	<p><b>O</b></p> 
<p>LONG GUARDRAIL 2 PCS</p>	<p>SHORT GUARDRAIL 2 PCS</p>	<p>LEFT LADDER END 1 PC</p>
<p><b>P</b></p> 	<p><b>Q</b></p> 	<p><b>R</b></p> 
<p>RIGHT LADDER END 1 PC</p>	<p>LADDER STEP 4 PCS</p>	<p>GUARDRAIL LEG 2 PCS</p>

# PARTS LIST

<p><b>S</b></p> 	<p><b>T</b></p> 	<p><b>U</b></p> 
<p>TOP HEADBOARD CENTER CROSS 2 PCS</p>	<p>SHORT GUARDRAIL POST 1 PC</p>	<p>BOTTOM HEADBOARD TOP CAP 2 PCS</p>
<p><b>V</b></p> 	<p><b>W</b></p> 	<p><b>X</b></p> 
<p>BOTTOM HEADBOARD TOP CROSS 2 PCS</p>	<p>BOTTOM HEADBOARD CENTER CROSS 4 PCS</p>	<p>BOTTOM HEADBOARD BOTTOM CROSS 2 PCS</p>
<p><b>Y</b></p> 	<p><b>Z</b></p> 	<p><b>A1</b></p> 
<p>BOTTOM SLAT CENTER WITHOUT HOLE 10 PCS</p>	<p>BOTTOM SLAT CENTER WITH HOLE 3 PCS</p>	<p>SUPPORT POST WITH LEVELER 3 PCS</p>
<p><b>B1</b></p> 	<p><b>C1</b></p> 	
<p>UPPER BED SLAT SPACE BLOCK 2 PCS</p>	<p>LOWER BED SLAT SPACE BLOCK 2 PCS</p>	

### IMPORTANT:

1. Do not tighten bolts completely until all bolts are completely lined up and inserted into holes / nuts.
2. Do not over tighten screws and bolts to avoid stripping.
3. Please use hand tools to assemble this product. Do not use power tools.
4. For ease of assembly, two adults are recommended.

### IMPORTANT:

1. Ne serrez pas complètement les boulons jusqu'à ce que tous les boulons soient complètement alignés et insérés dans les trous / écrous.
2. Ne pas trop serrer les vis et les boulons pour éviter d'endommager les filets.
3. Utilisez des outils à main pour assembler ce produit. N'utilisez pas d'outils électriques.
4. L'assemblage par deux adultes est recommandé.

### IMPORTANTE:

1. No apriete completamente los pernos hasta que todos los tornillos estén alineados completamente y se inserten en los agujeros / tuercas.
2. No apriete demasiado los tornillos y los pernos para evitar dañar los filetes.
3. Utilice herramientas de mano para montar este producto. No utilice herramientas eléctricas.
4. Se recomienda el montaje por dos adultos.

## STEP 1

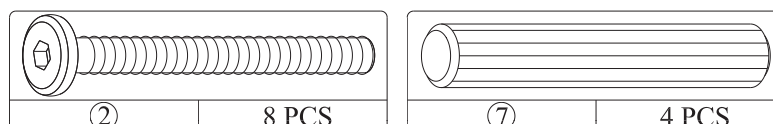
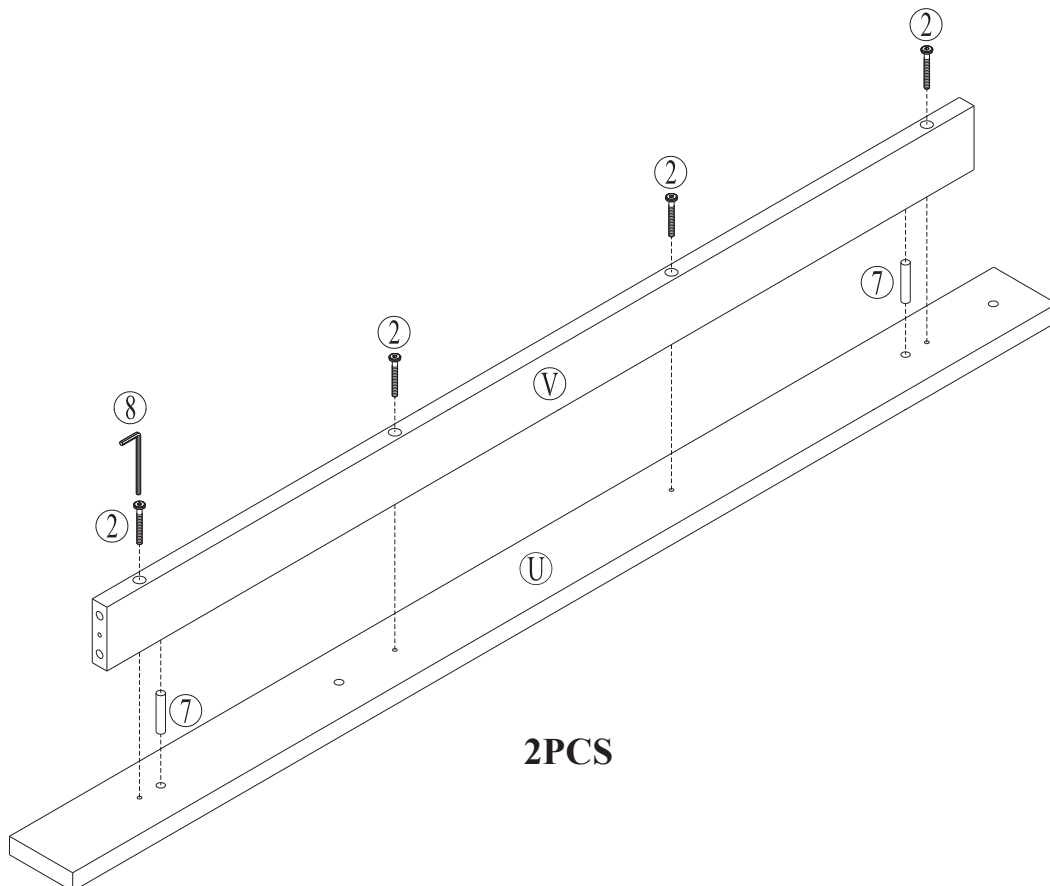

## STEP 2

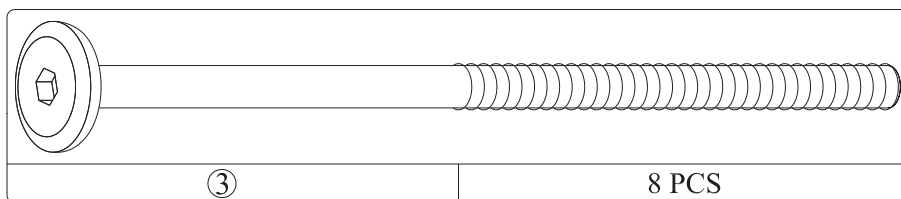
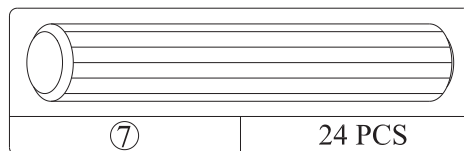
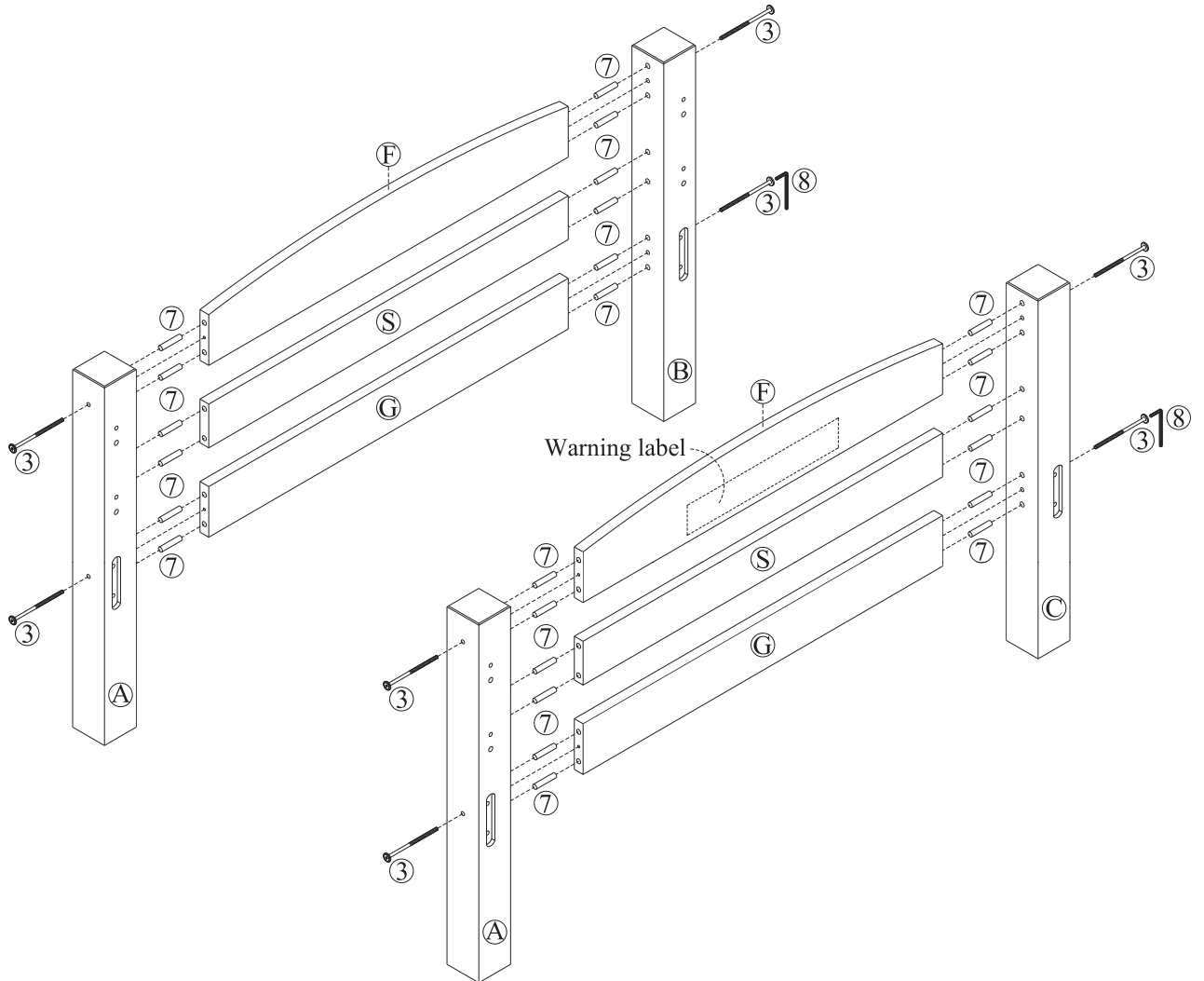

# STEP 3

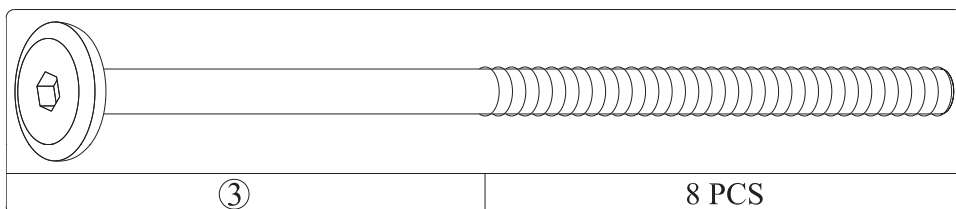
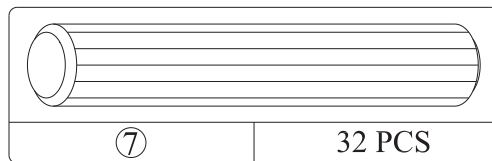
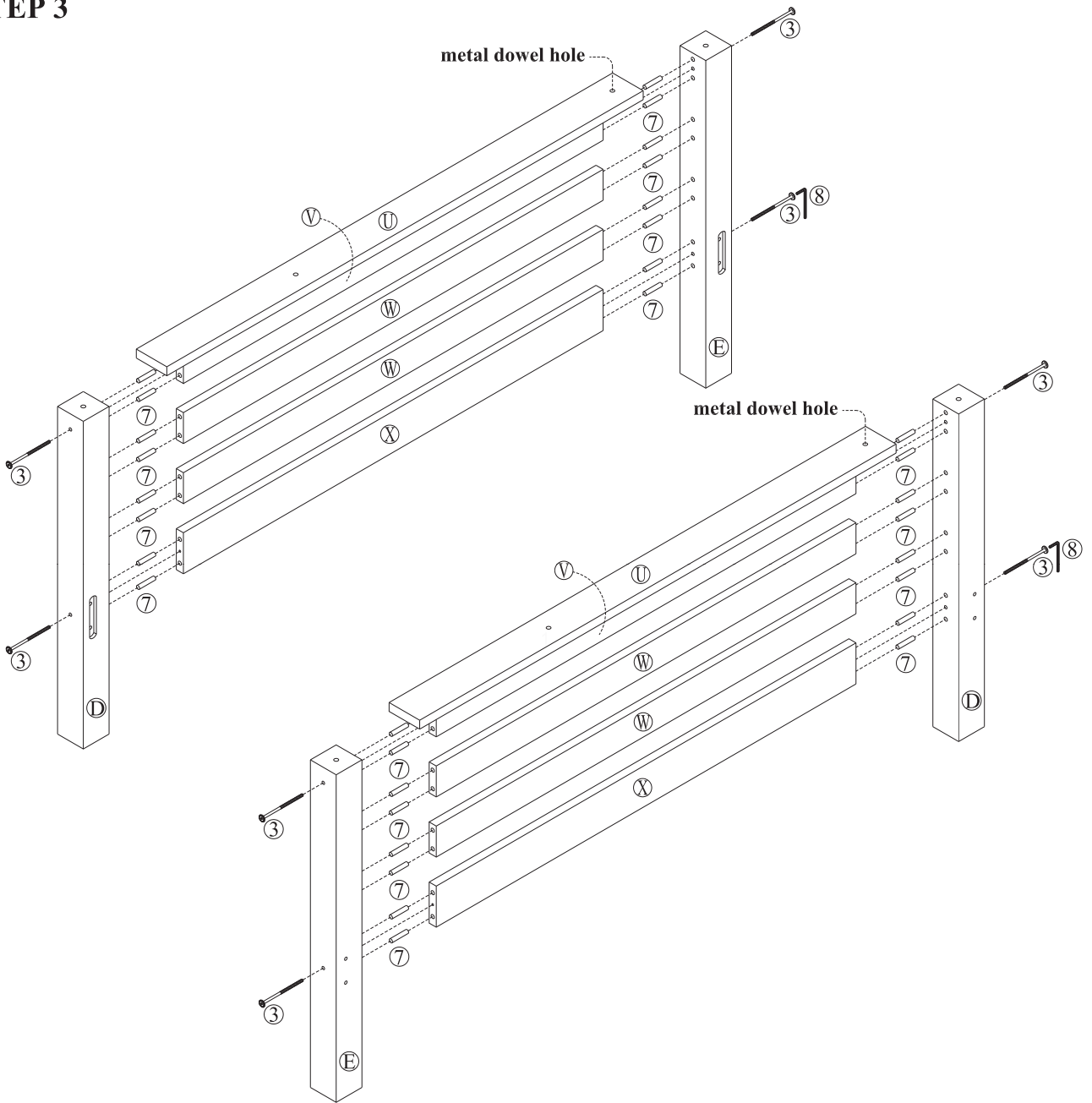

# STEP 4

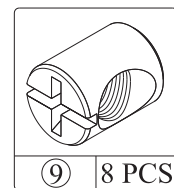
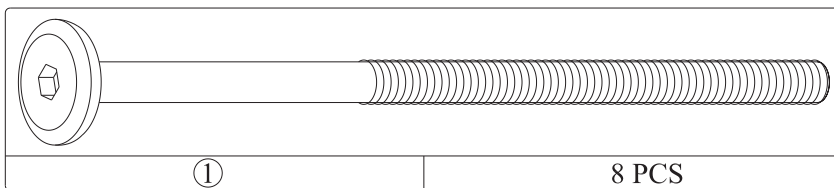
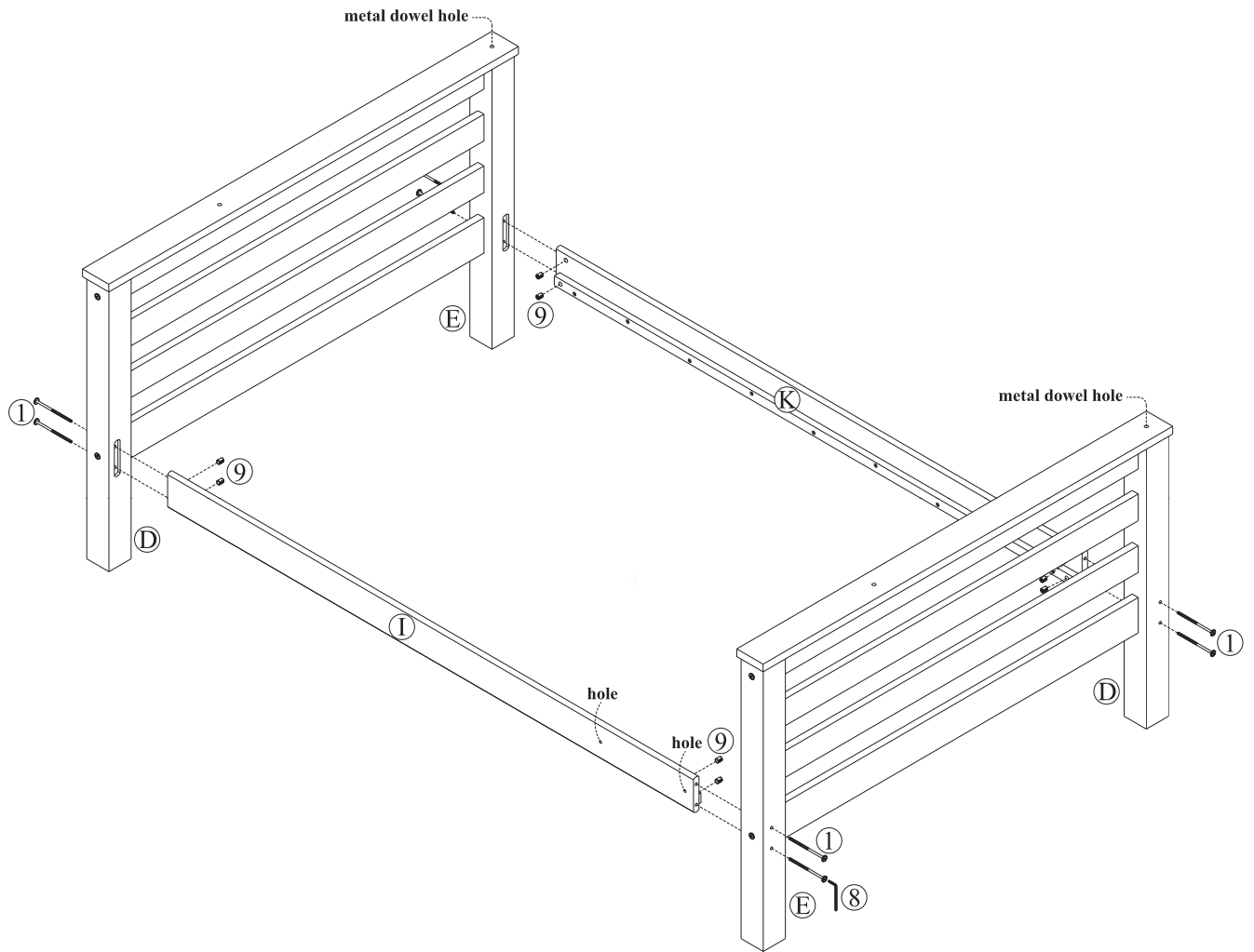

# STEP 5

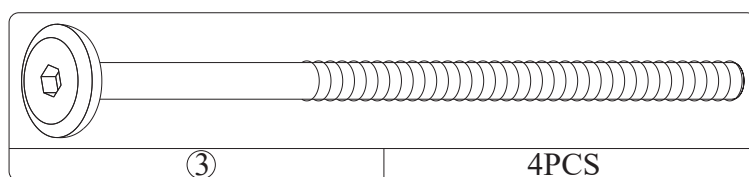
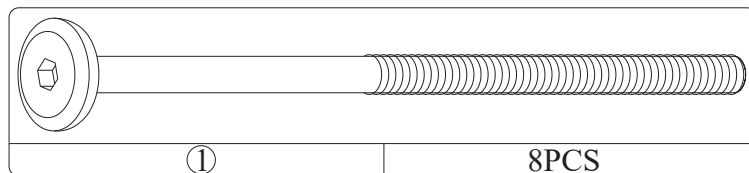
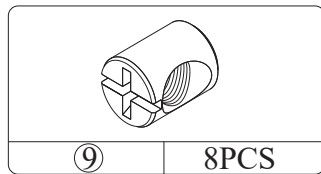
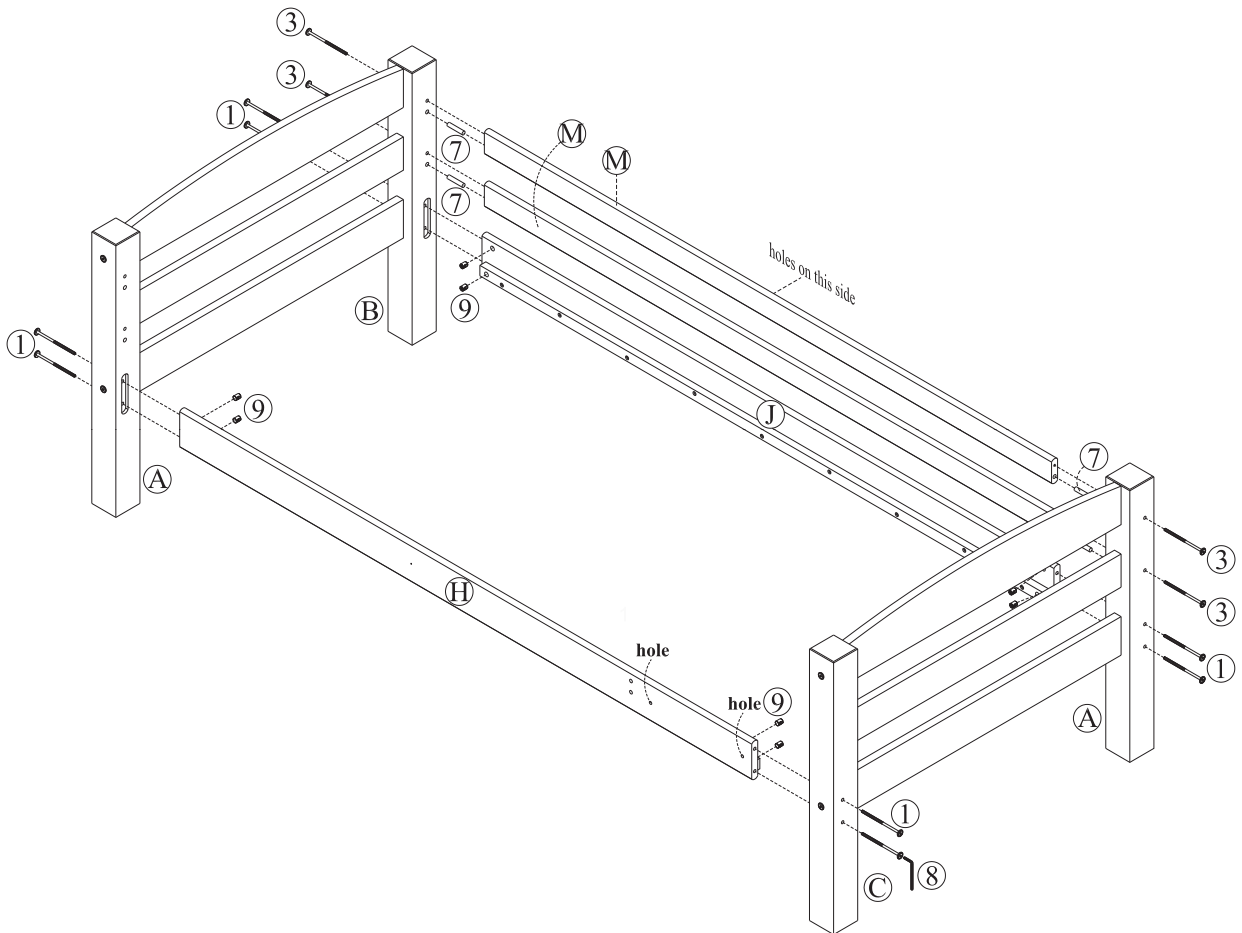

# STEP 6

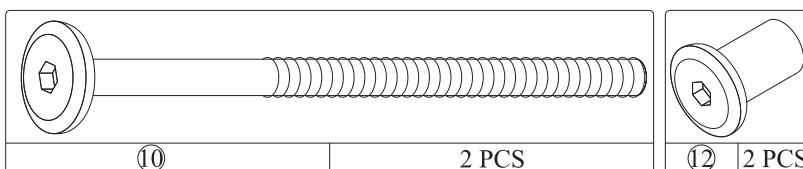
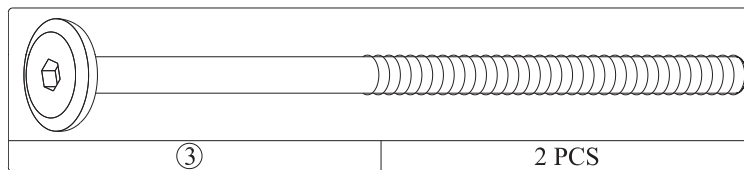
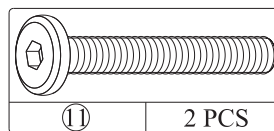
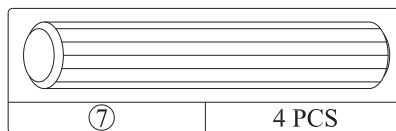
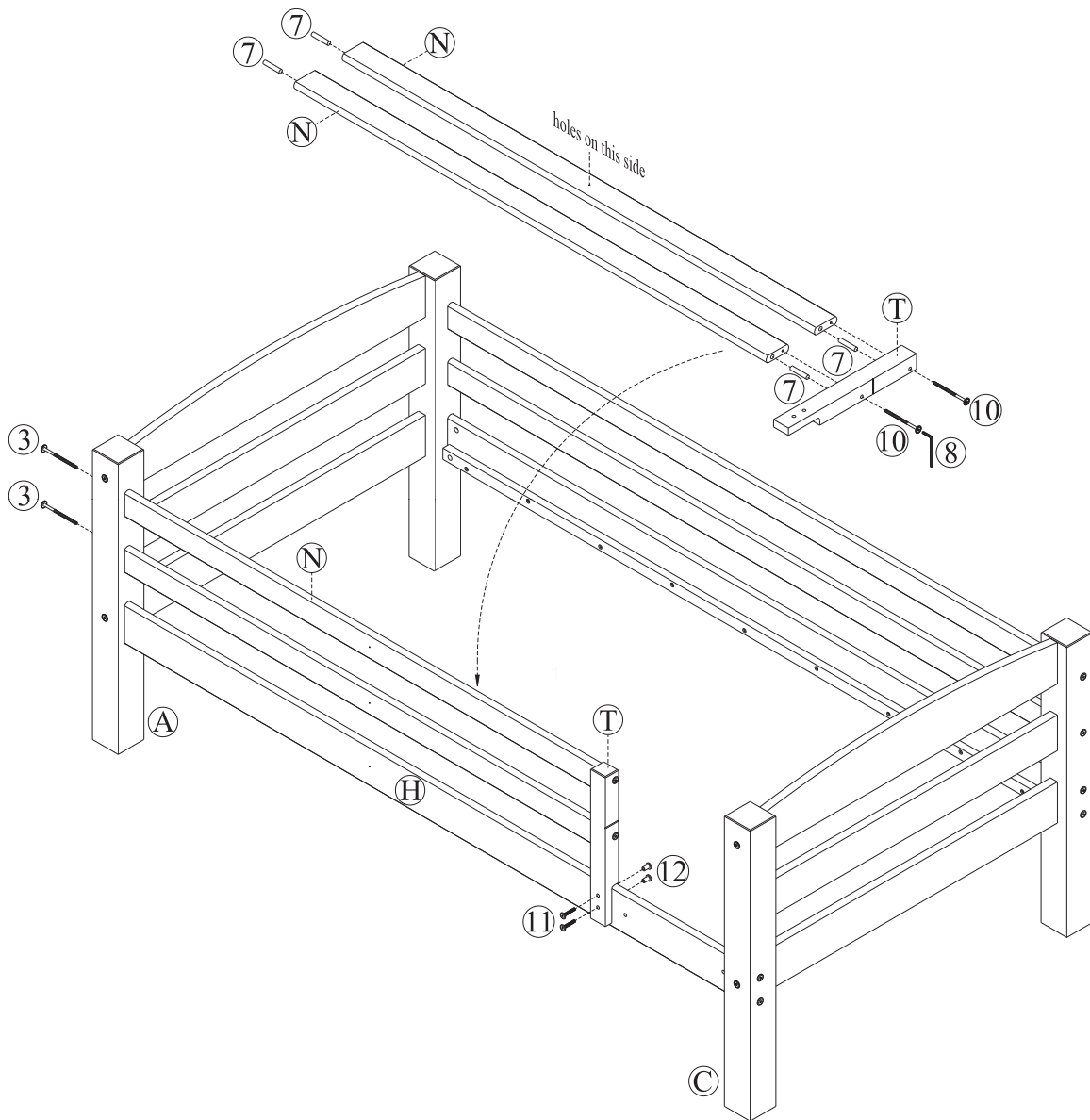

**STEP 7**

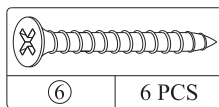
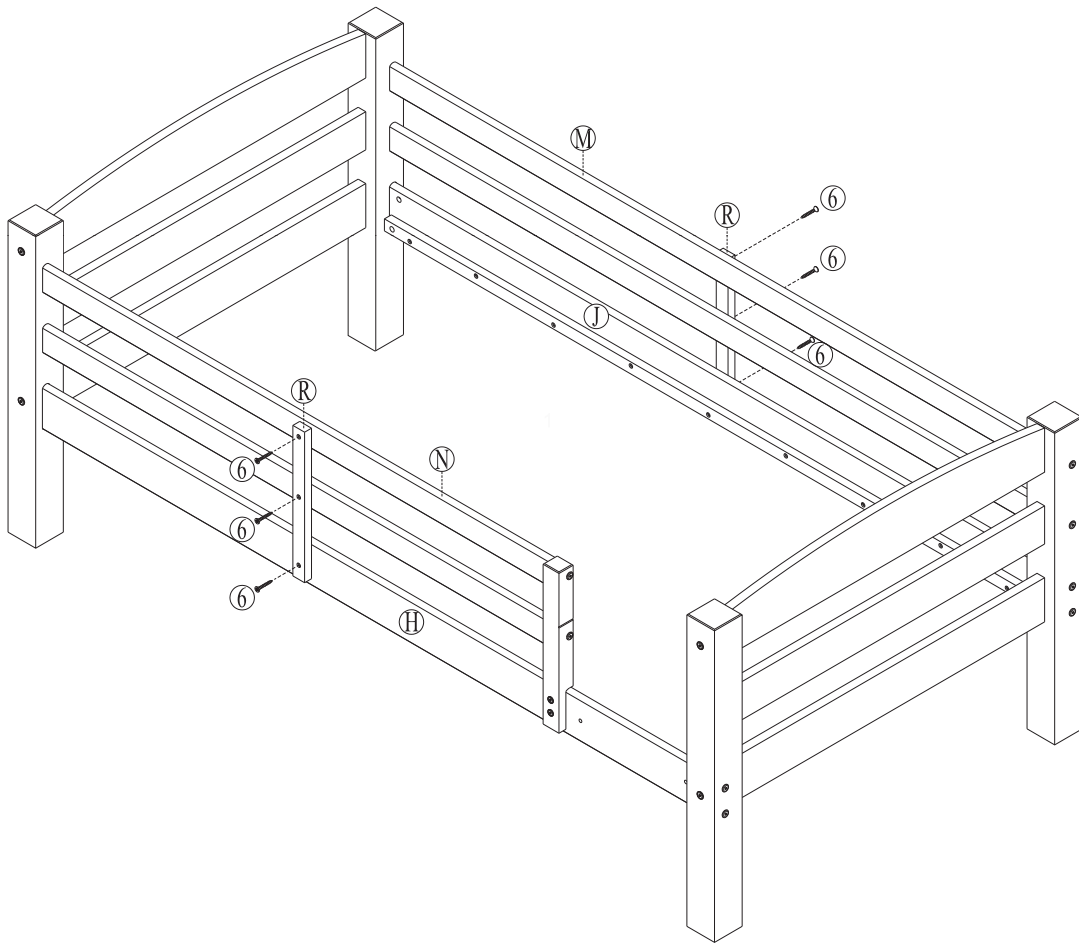

# STEP 8

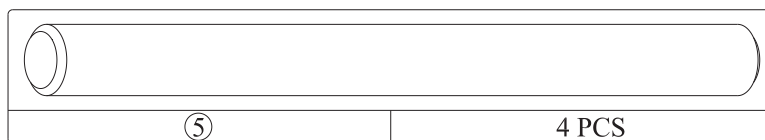
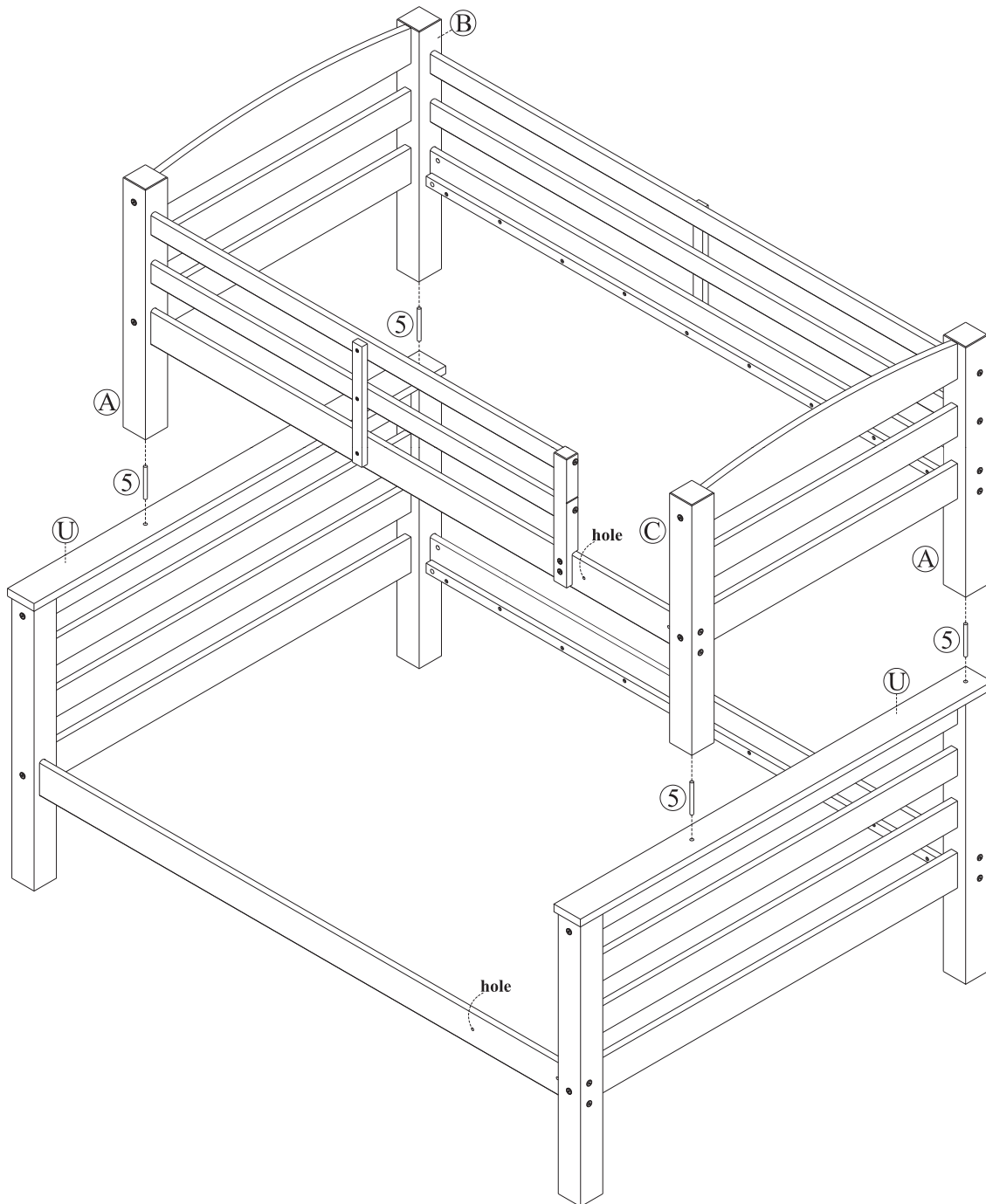

**STEP 9**

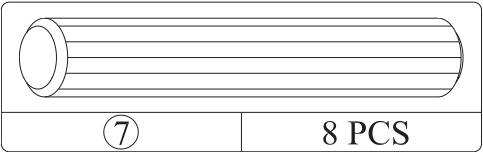
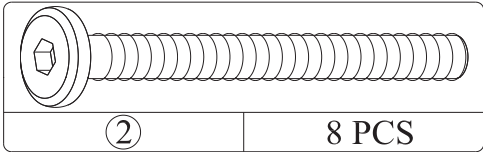
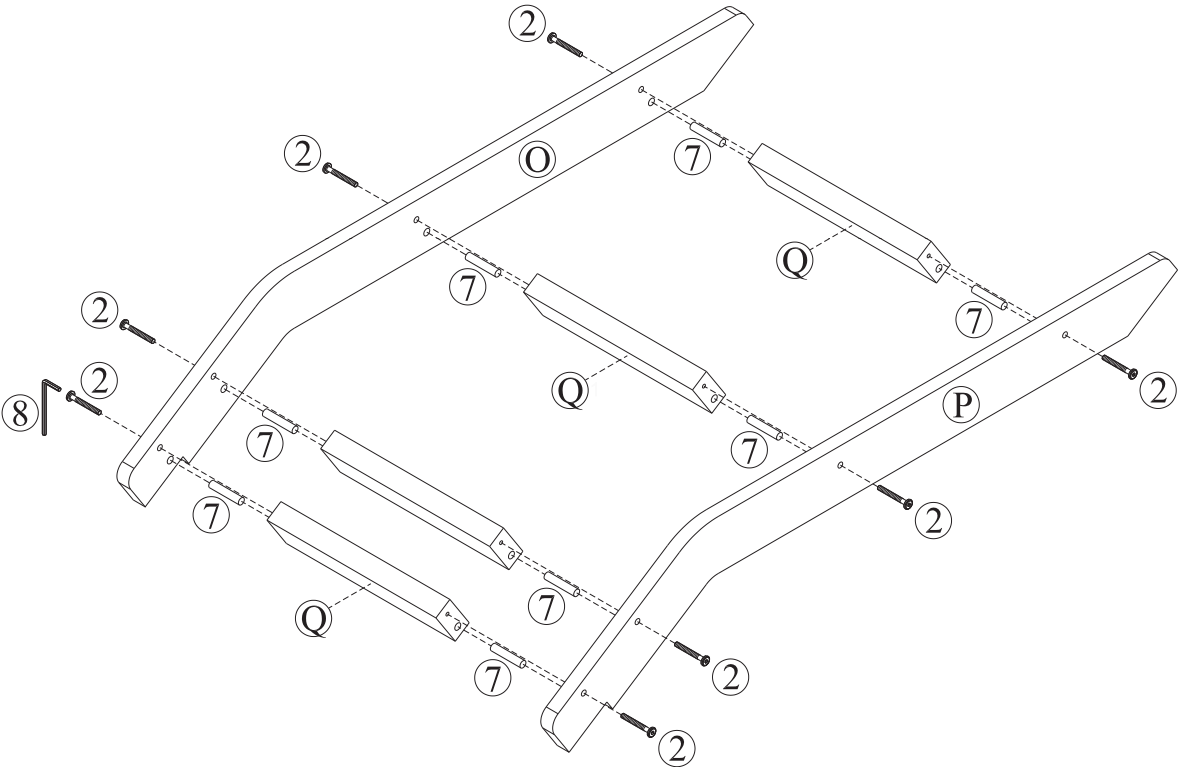

# STEP 10

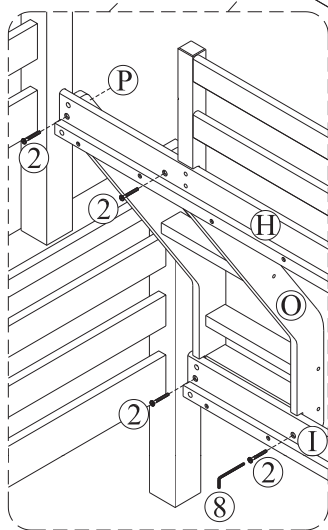
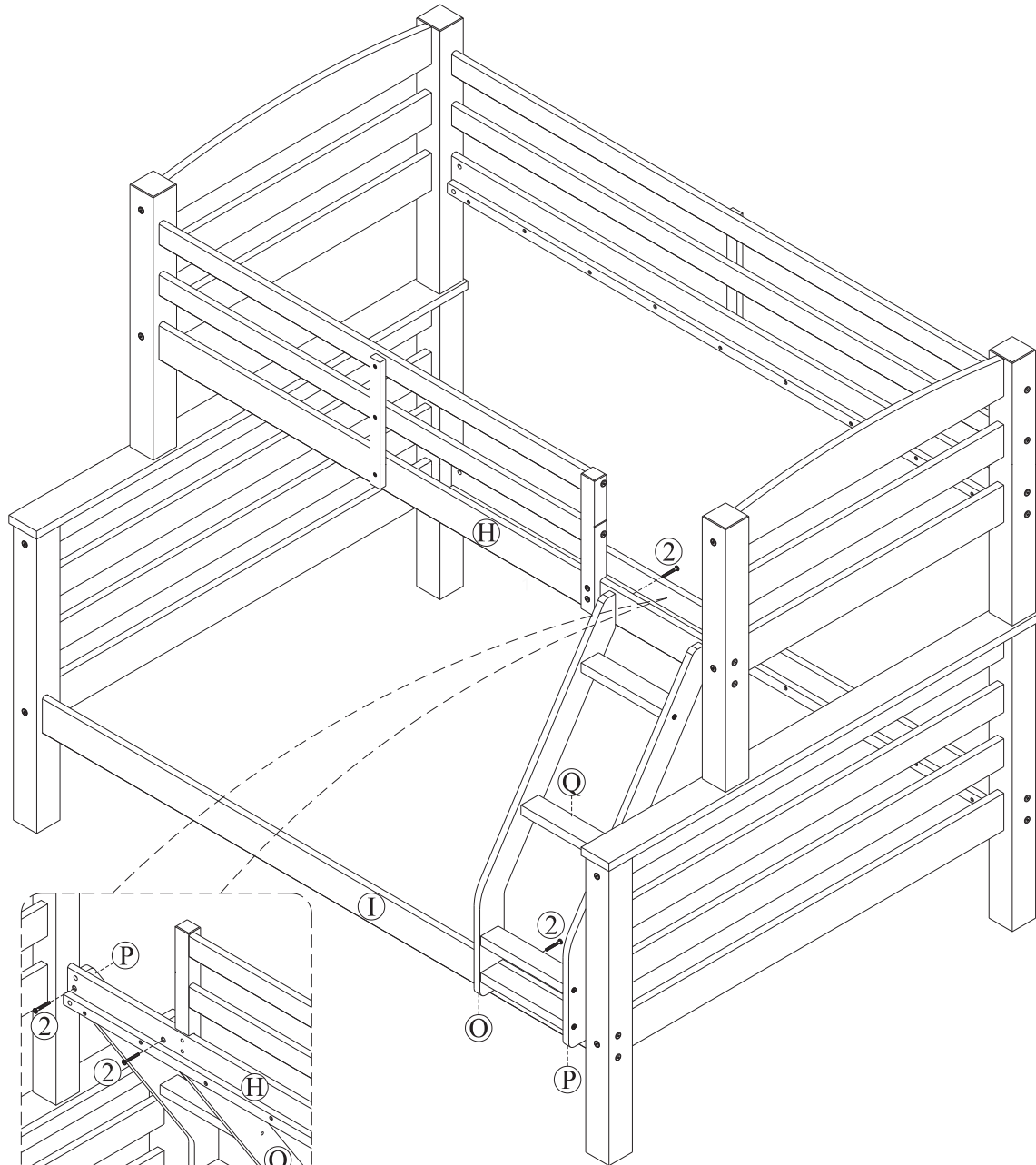

back view

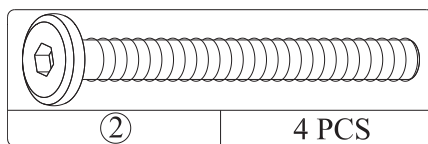

# STEP 11

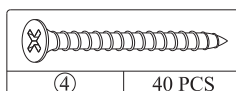
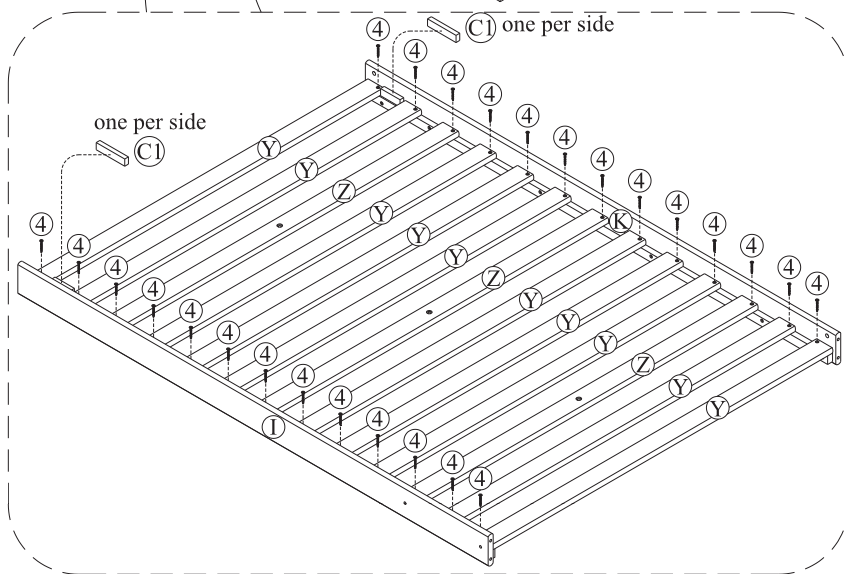
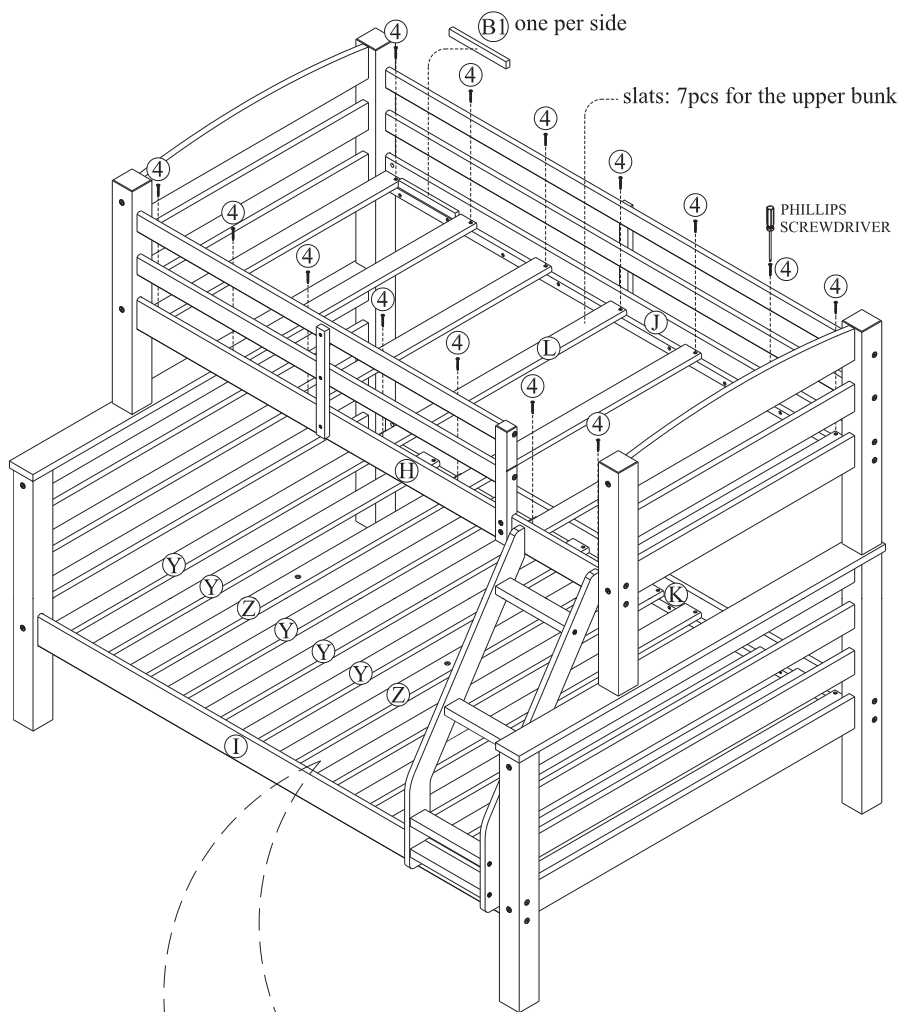

**STEP 12**

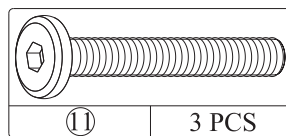
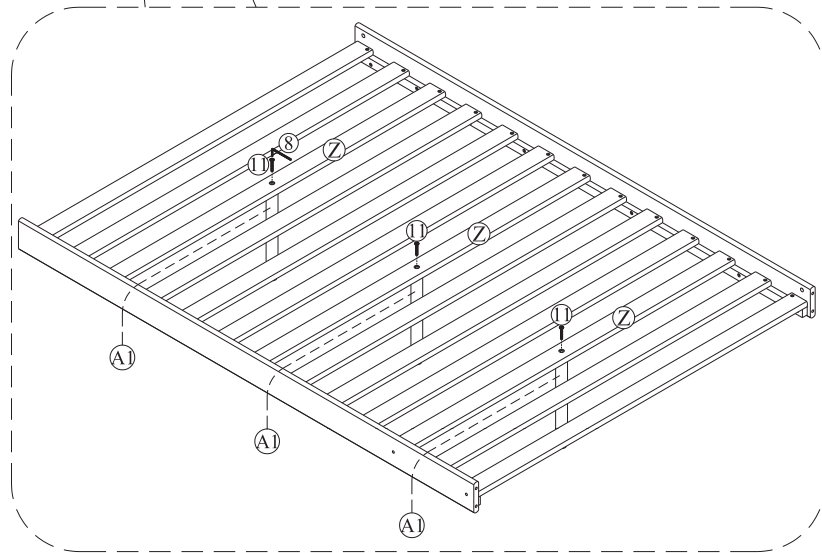
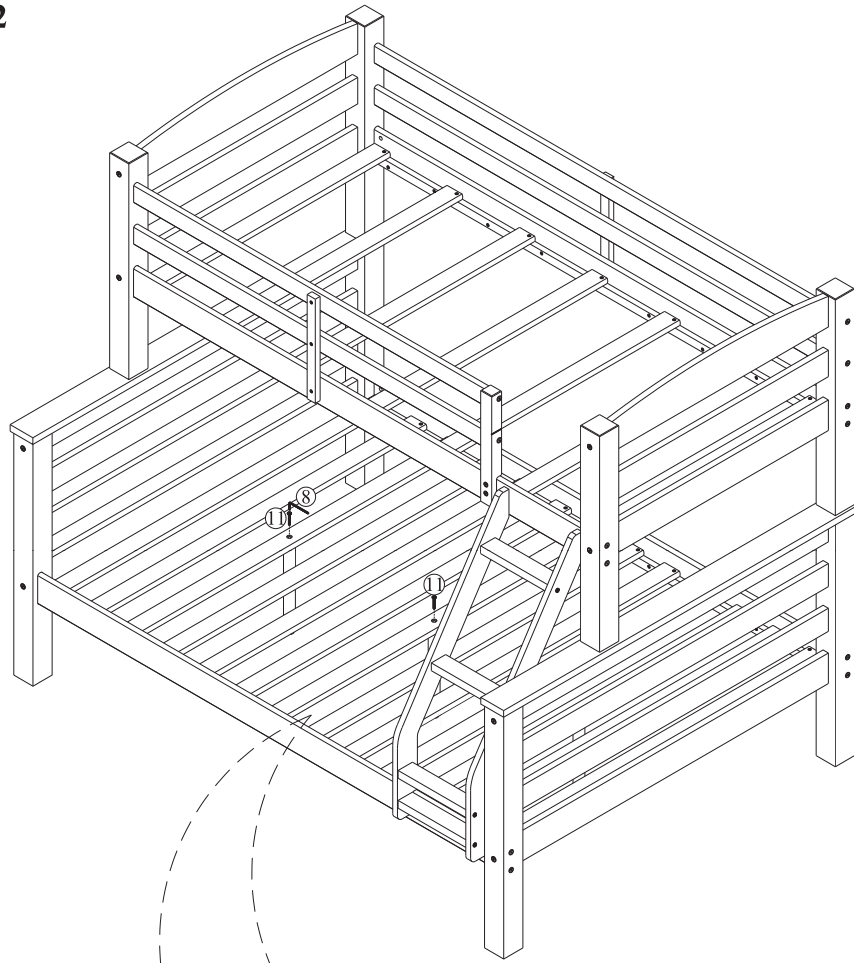

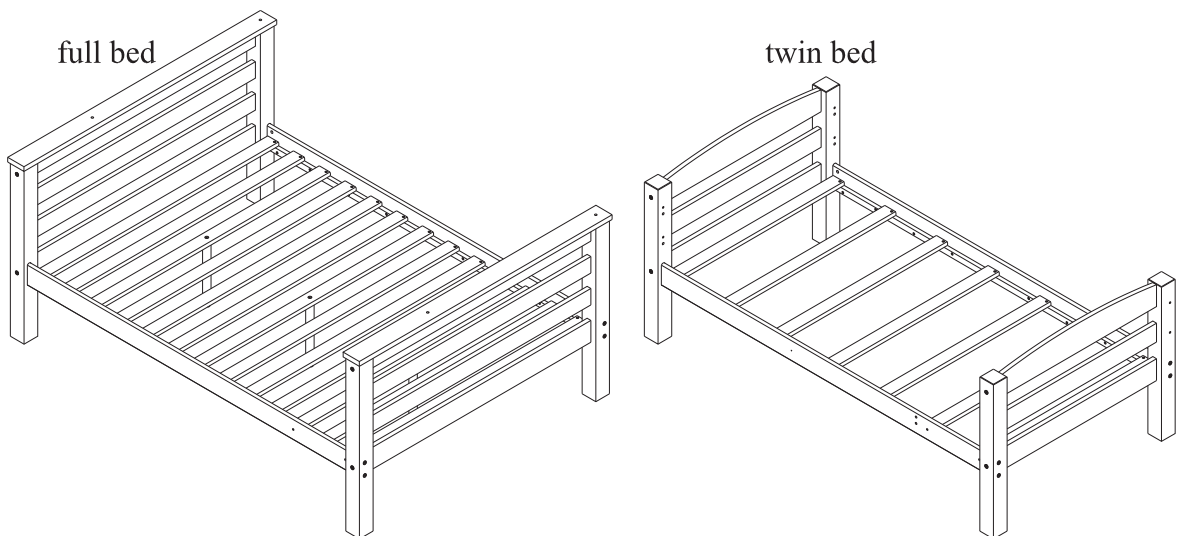
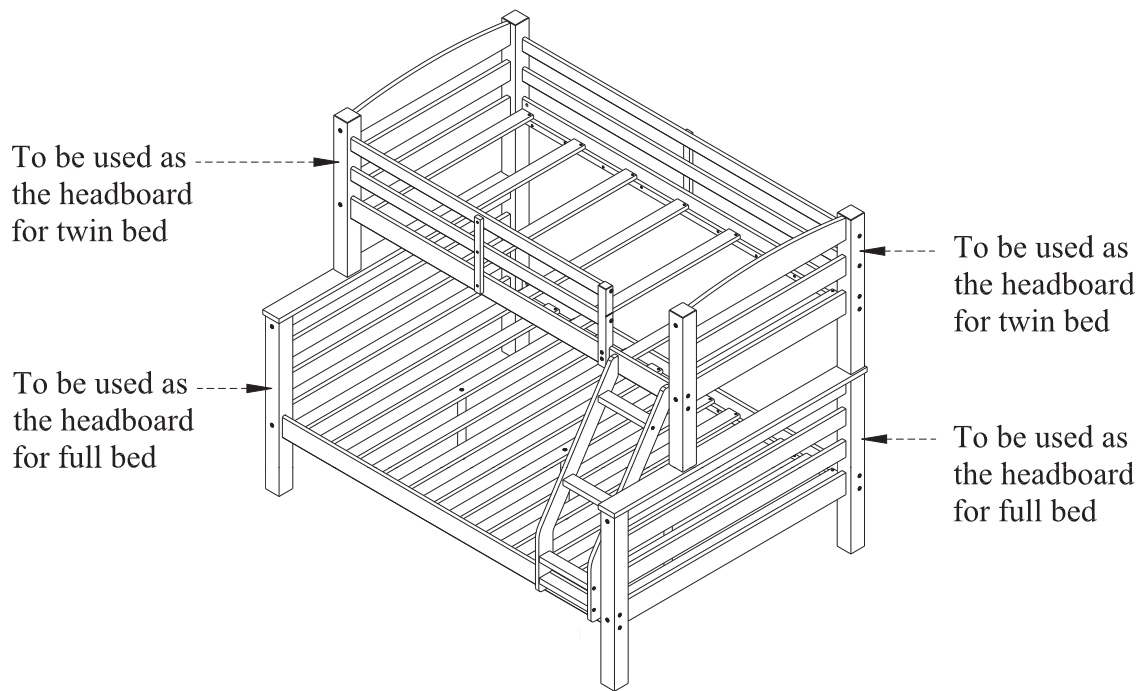

To convert the bunk bed into a full size bed and a twin bed, remove the ladder and all the guardrails. With the help of another person, remove the top bunk from the lower bunk.



**CAUTION:** This unit is intended for use only with the products and/or maximum weights indicated. Use with other products and/or products heavier than the maximum weights indicated may result in instability or cause possible injury.

**DO NOT ALLOW HORSEPLAY ON OR UNDER THE BED AND PROHIBIT JUMPING ON THE BED.**

**DO NOT ALLOW CHILDREN UNDER 6 YEARS OF AGE TO USE THE UPPER BUNK. BED IS DESIGNED FOR CHILDREN RANGING FROM 6 YEARS OF AGE TO YOUNG TEENAGERS.**

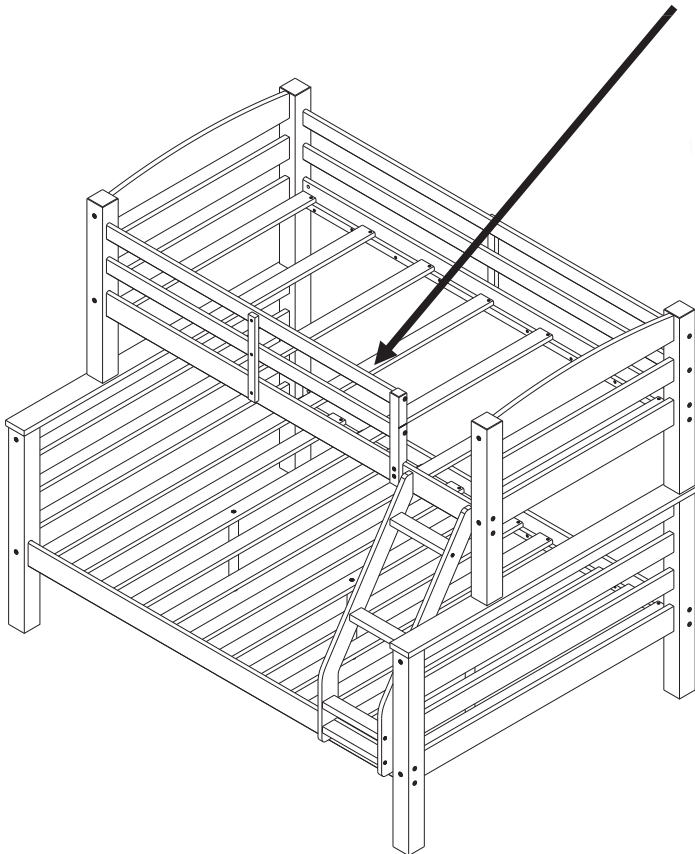

**USE ONLY COIL SPRING MATTRESSES ON BOTH THE UPPER AND LOWER BUNKS. FAILURE TO DO SO CAN RESULT IN INJURY.**

**USE ONLY MATTRESSES WHICH ARE 74"-75" LONG AND 37 1/2" - 38 1/2" WIDE ON UPPER BUNK AND FULL MATTRESSES WHICH ARE 74"-75" LONG AND 53"-54" WIDE ON LOWER BUNK. ENSURE THICKNESS OF MATTRESS DOES NOT EXCEED 8".**

That's it! You've finished assembling your bunk bed.

---

 **WARNING TO HELP PREVENT SERIOUS OR FATAL INJURIES FROM ENTRAPMENT OR FALLS:**

---

- Never allow a child under 6 years old on the upper bunk.
- Always use the recommended size mattress or mattress support, or both, to help prevent the likelihood of entrapment or falls.
- Use only mattresses which are 74"-75" long and 37 1/2"-38 1/2" wide on upper bunk and full mattresses which are 74"-75" long and 53"-54" wide on lower bunk.
- Ensure thickness of mattress does not exceed 8" and surface of mattress is at least 5" below upper edge of guardrails.
- Always use guardrails on both long sides of the upper bunk.
- If bunk bed will be placed next to a wall, the guardrail that runs the full length of the bed should be placed against the wall to prevent entrapment between the bed and the wall.
- Prohibit horseplay on or under bed(s) and prohibit jumping on the bed.
- Prohibit more than one person on upper bunk.
- Use ladder for entering and leaving upper bunk.
- Maximum total weight is not to exceed 300 lbs. on the upper bunk.
- Periodically check and ensure that the guardrail, ladder, and other components are in their proper position, free from damage, and that all connectors are tight.
- Do not use substitute parts. Replacement parts, including additional guardrails, may be obtained from our customer service department.
- Use of water or sleep flotation mattresses is prohibited.
- Use of a night light may provide added safety precaution for a child using the upper bunk.
- Follow the information on the warnings appearing on the upper bunk end structure and on the carton
- Keep these instructions for future reference.

**STRANGULATION HAZARD** Never attach or hang items to any part of the bunk bed that are not designed for use with the bed; for example, but not limited to, hooks, belts and jump ropes.

**DO NOT REMOVE WARNING LABEL FROM BED. KEEP THESE INSTRUCTIONS FOR FUTURE REFERENCE.**

---

## LIMITED 6 MONTHS WARRANTY

## GARANTIE LIMITÉE DE 6 MOIS

## GARANTÍA LIMITADA DE 6 MESES

### WHAT IS COVERED

This product is covered under our manufacturer's 6 months limited warranty. To ensure your complete satisfaction, this warrants to the original purchaser that the Powell supplied item is free from defects in material and workmanship, as of the date of purchase, and that it will, under normal use and proper care, remain so for six months after the date of purchase.

Replacement of missing or initially defective parts will be sent, at no charge, for a period of 30 days from the date of purchase with valid proof of purchase providing the parts are available in our warehouse and the item purchased is part of our current inventory.

### WHAT IS NOT COVERED

It remains the customer's responsibility for freight and packaging charges to and from the customer service center. Labor and material charges to remove or replace parts under this warranty are not covered.

This warranty does not cover: Furniture used for commercial purposes, failures caused by improper installation assembly or by improper care, unreasonable or abusive use, freeze damage, acts of God, rust, purchased parts or return freight and packaging charges. Proof of purchase (dated register receipt) is required for warranty claims.

### QU'EST-CE QUI EST COUVERT

Ce produit est couvert sous une garantie limitée de 6 mois offerte par le fabricant. Afin d'assurer votre entière satisfaction, cela garantit à l'acheteur original que le produit fourni est exempt de défauts de matériaux et de fabrication à compter de la date d'achat, et ce, sous des conditions d'utilisation normales et de soins adéquats, valide pendant six mois après la date d'achat.

Le remplacement de pièces manquantes ou défectueuses dès le départ sera envoyé, sans frais, pour une période de 30 jours suivant la date d'achat avec une preuve d'achat valide pourvu que les pièces soient disponibles dans notre entrepôt et que l'article acheté fait partie de notre inventaire actuel.

### QU'EST-CE QUI N'EST PAS COUVERT

Il y va de la responsabilité du client de couvrir les frais de transport et d'emballage vers et à partir du centre de service après-vente. Les frais de la main-d'œuvre et des matériaux pour retirer les pièces ou les remplacer sous cette garantie ne sont pas couverts.

Cette garantie ne couvre pas : les meubles utilisés à des fins commerciales, les défaillances causées par un mauvais assemblage ou entretien (sans dépasser les limites de poids), l'utilisation déraisonnable ou abusive, les dommages causés par le gel, la rouille, les frais de transport et d'emballage pour des pièces achetées ou retournées. Une preuve d'achat (reçu de caisse daté) est requise pour les réclamations sous garantie.

### QUÉ ESTÁ CUBIERTO

Este producto está cubierto por la garantía limitada de 6 meses de nuestro fabricante. Para asegurar su total satisfacción, ésta garantiza al comprador original que el artículo proporcionado se encuentra libre de defectos materiales y de fabricación, a partir de la fecha de compra, y que permanecerá en tal estado, sometido a un uso normal y cuidados adecuados, durante los seis meses posteriores a la fecha de la compra.

Las partes faltantes o que presenten defectos al inicio de ese período de tiempo serán enviadas sin cargo, durante un lapso de 30 días a partir de la fecha de compra, mediante la presentación de un comprobante de compra válido, siempre que las partes estén disponibles en nuestro almacén y el artículo adquirido sea parte de nuestro inventario actual.

### QUÉ NO ESTÁ CUBIERTO

El cliente asumirá los costos de flete y empaque hacia y desde el centro de servicio de cliente. Los cargos de material y mano de obra para extraer o reemplazar partes en el marco de la garantía no están cubiertos.

Esta garantía no cubre: muebles utilizados con fines comerciales, fallas causadas por montaje de instalación inadecuados o uso indebido (se recomienda no exceder los límites de peso), uso no razonable o abusivo, daños por congelación, oxidación, partes compradas, flete de devolución y cargos de empaque. Se exigirá el comprobante de compra (la factura de registro con fecha) para hacer valer la garantía.