

COFFEE TABLE

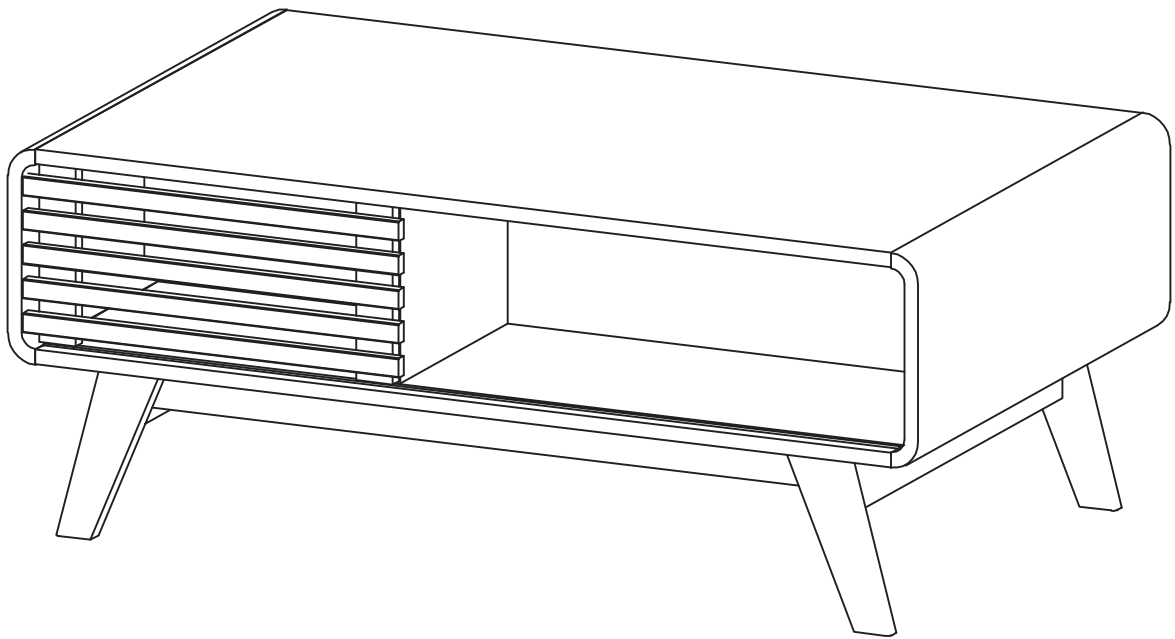

ASSEMBLY INSTRUCTIONS

Enjoy your 1-Year Warranty

We've got more for you. Be part of and enjoy:

- Privileged Customer Care
- 10% Off Your Next Purchase (no min spend)
- 1-Year Free Warranty
- Early Access To Upcoming Launches

Before you start...

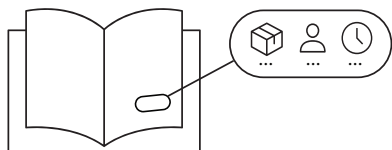

Ensure you have received all cartons and familiarize yourself with the workload. Make sure there are enough helping hands to assist you, and that you have allocated the time required to assemble your new product.

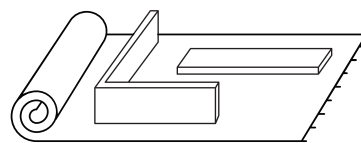

Make sure you have cleared enough space in your home for the assembly. We recommend protecting your floor with a mat or cardboard to avoid scratches during the assembly process.

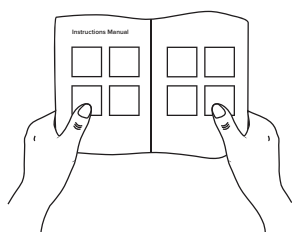

Read instructions carefully and check no parts are missing.

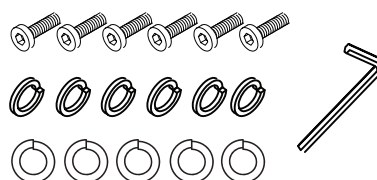

Lay out all hardware on a soft surface so you can easily identify them.

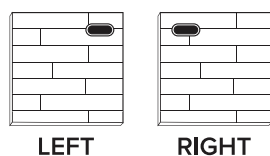

Carefully identify all components in order to differentiate which pieces are left and right.

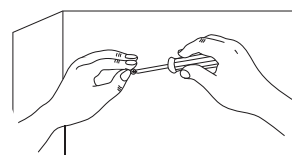

Install your new product carefully following the instructions. Don't skip ahead!

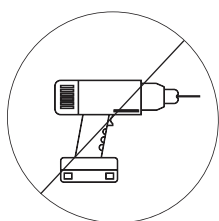







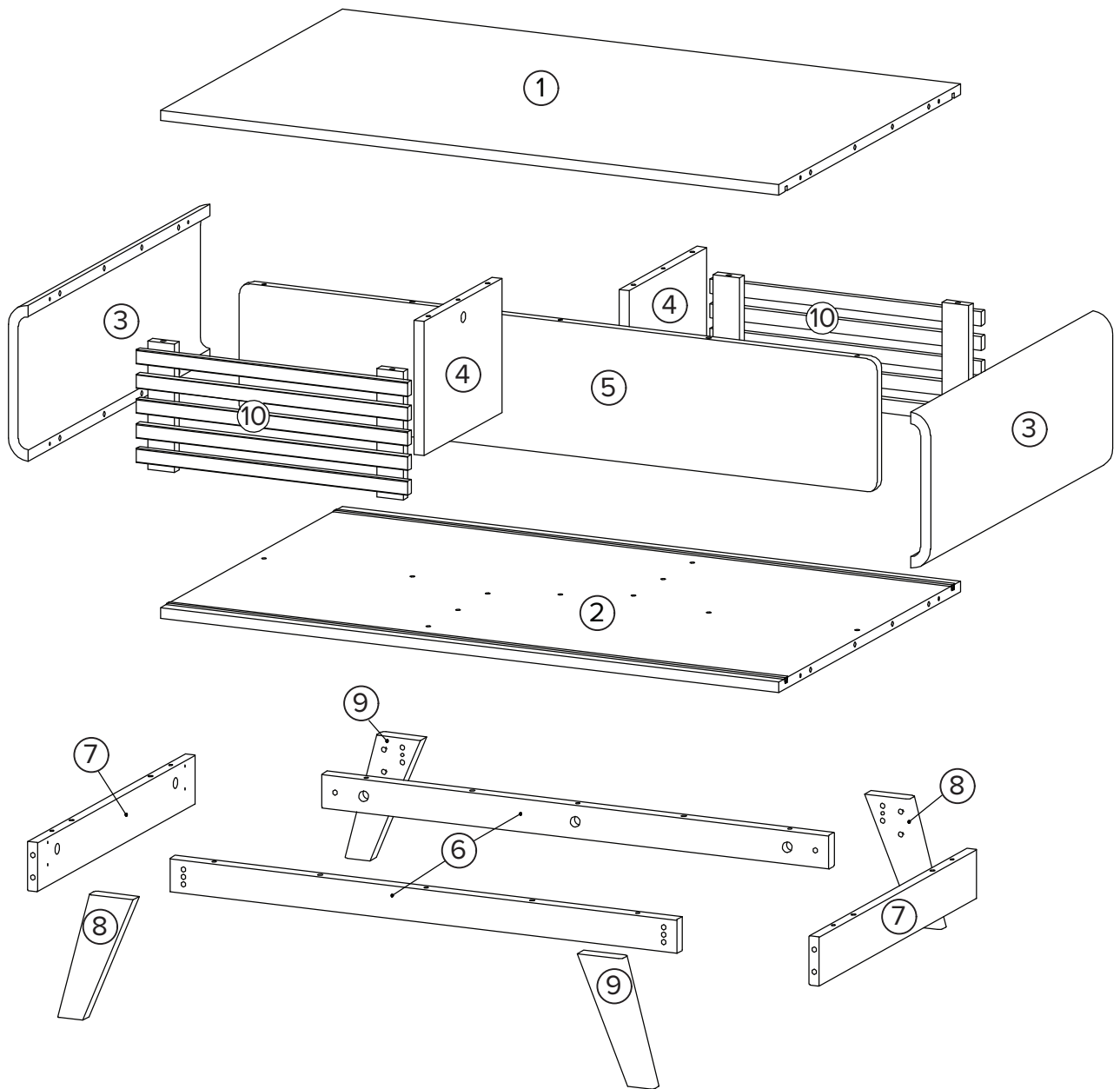

DO NOT over tighten screws or use a drill. It will damage the product.

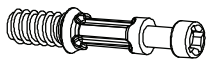
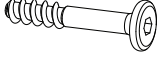

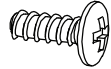
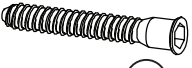

Parts

- ① x1
- ② x1
- ③ x2
- ④ x2
- ⑤ x1
- ⑥ x2
- ⑦ x2
- ⑧ x2
- ⑨ x2
- ⑩ x2

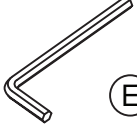
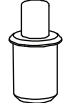

Hardware

<input type="checkbox"/>		Cambolt Ø 6 x 35 mm x23	<input type="checkbox"/>		Screw M 6.4 x 35 mm x4	<input type="checkbox"/>		Pin Sliding Bottom x4
<input type="checkbox"/>		Camlock Ø 15 mm x23	<input type="checkbox"/>		Bracket x4	<input type="checkbox"/>		Floor Protector x4
<input type="checkbox"/>		Dowel Ø 8 x 30 mm x52	<input type="checkbox"/>		Screw M 4.5 x 12.5 mm x8			
<input type="checkbox"/>		Screw M 7 x 50 mm x5	<input type="checkbox"/>		Buffer Ø 8 mm x4			
<input type="checkbox"/>		Allen Key L 4 x1	<input type="checkbox"/>		Pin Sliding Top x4			

-  There are inner box(es) that include components required to complete this assembly.
-  Please do not completely tighten all the hardware, until each assembly step is complete.
-  Before discarding the packaging, please use the checklist to ensure that you have all the parts required to assemble your product. Please kindly note you will need the original package if you want to return the product later.
-  If parts are missing or damaged, we will gladly ship your replacements parts free of charge.



x1



x2



60 mins

Pre-Assembly

Panels and boards are not packed in accordance to assembly step. Suggestion to unpack everything before starting.

A string is attached to hardware box for easy access.

Step 1

Ensure your floor is properly protected, then take out board No.1, No.2 and 2 pieces of No.4. Screw cambolt A to board No. 1 (don't over screw). Plug in dowel C into side holes of board No.1, 2 and 4.

Please ensure you screw or plug into the correct hole according to the illustration.

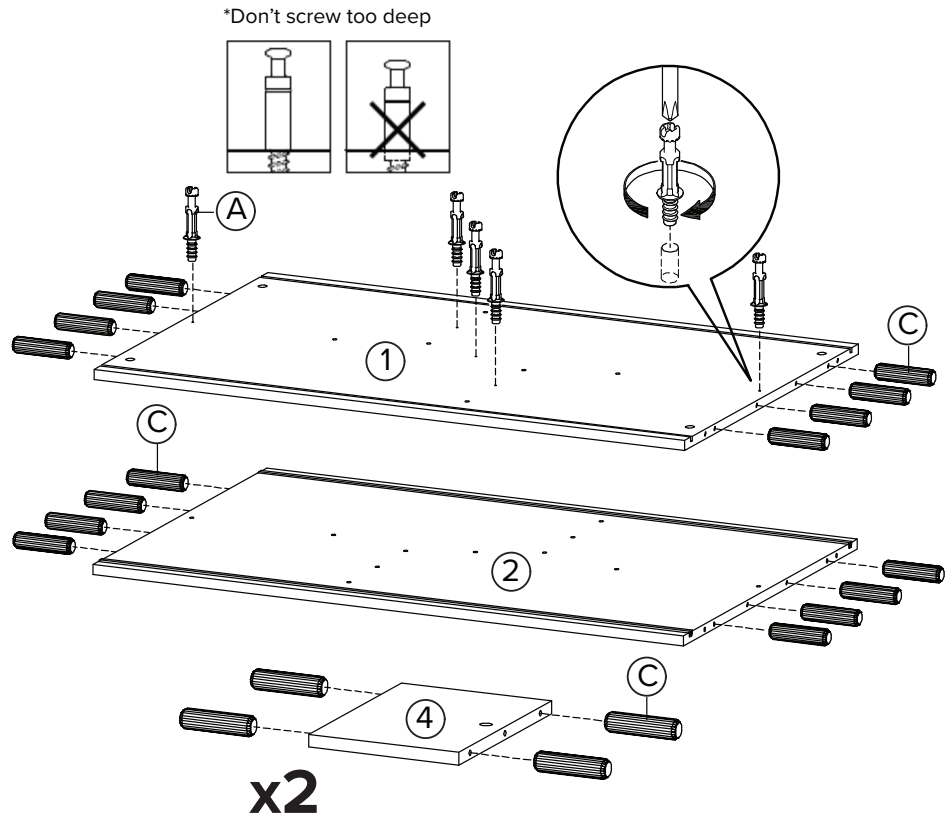
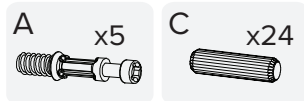

Step 2

Take out board No.3 and screw cambolt A into the indicated position. Take out board No.5 and plug in dowel C to the side holes.

Please ensure you screw or plug into the correct position according to the illustration. Don't over screw.

*Don't screw too deep

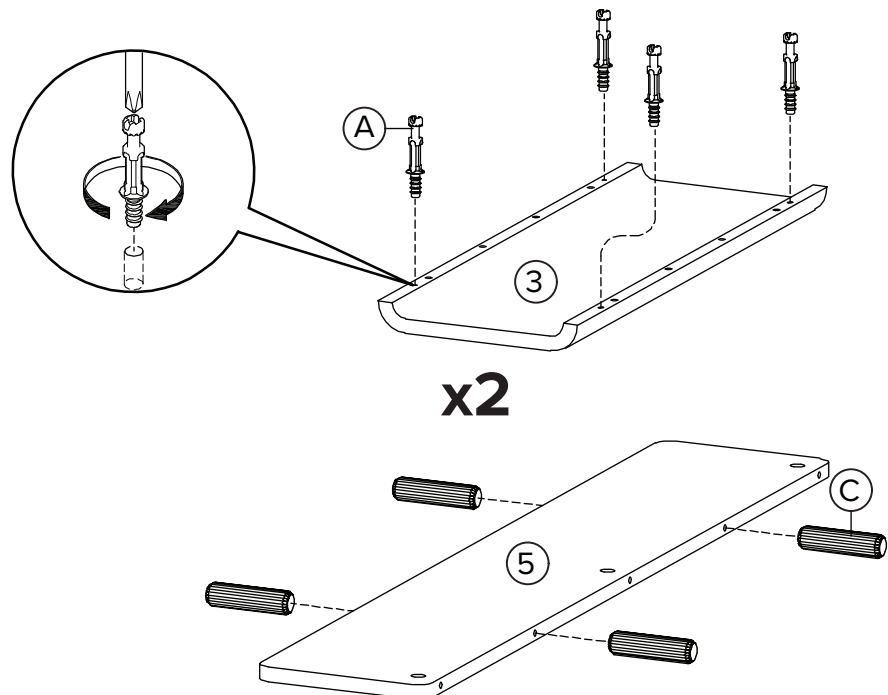
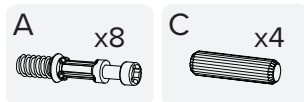
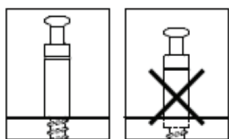

Step 3

Install board No.5 onto board No.1 by inserting camlock B to indicated holes, engaging cambolt A installed on board No.1 in previous step, and then tightening camlock B with Allen key provided or a screw driver.

We recommend using cardboard or foam to lift up board No.1 to finish this step to avoid scratch due to screwing action.

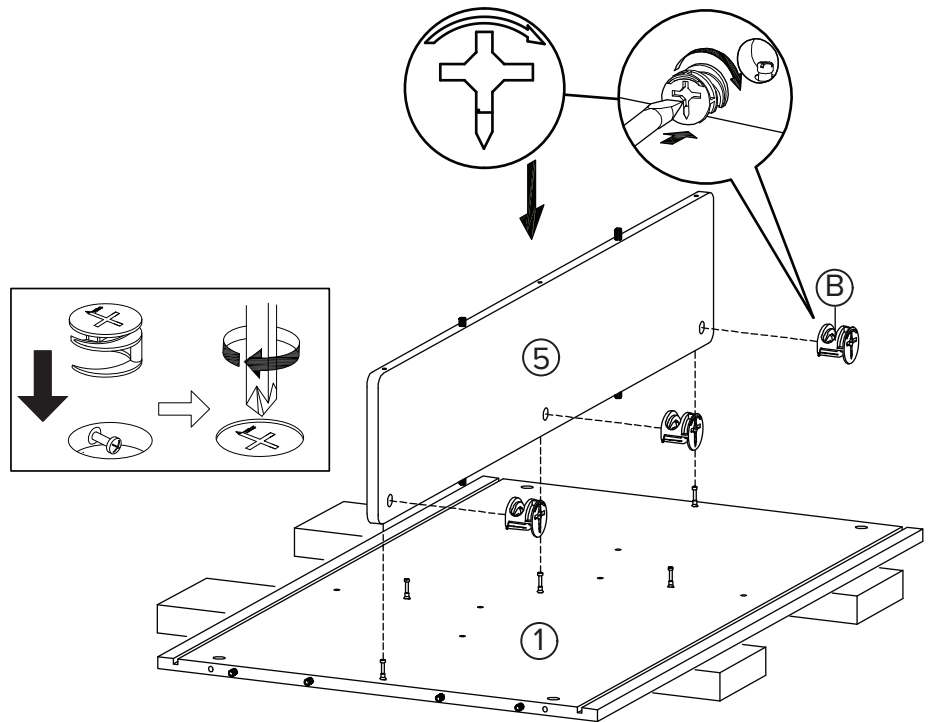

Step 4

Install 2 pieces of board No.4 onto board No.1 by inserting camlock B and tightening it with Allen key provided or a screw driver.

Please ensure the correct orientation for individual board No.4 and the camlock placing orientation. Check the illustration carefully.

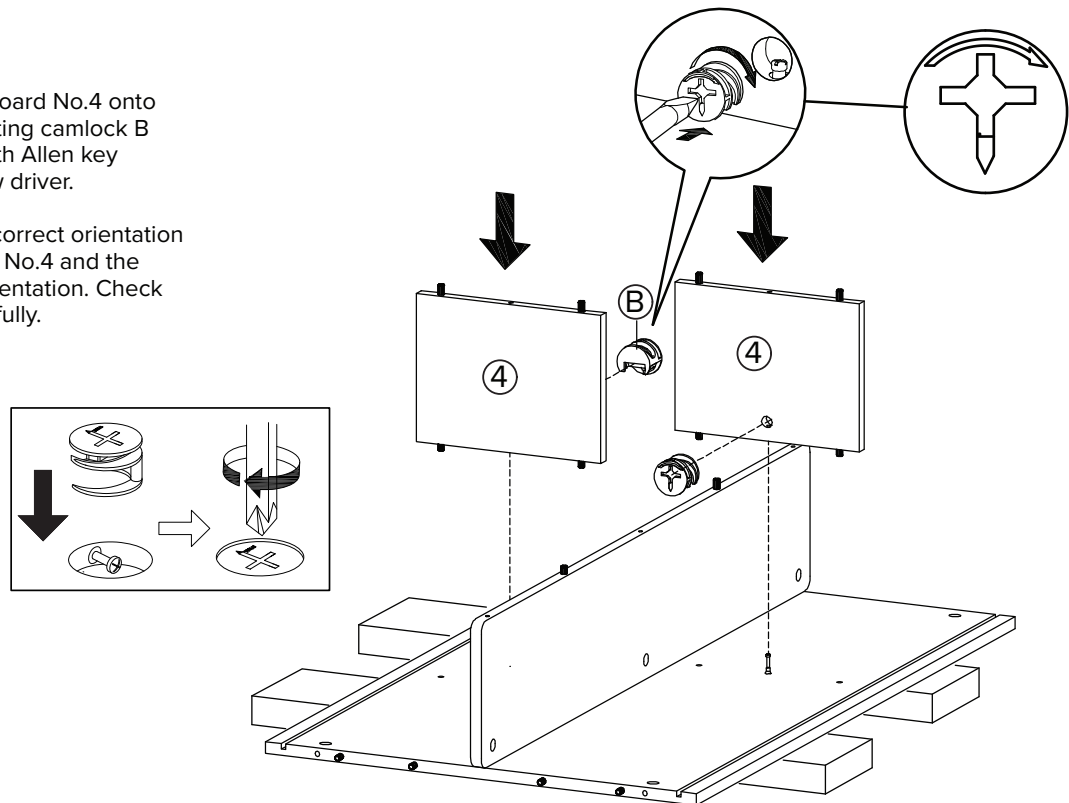

Step 5

Put board No.2 on top.
Insert screw D into holes
indicated and screw in with
Allen key E.

Please don't fully tighten
until all screws are engaged
and screwed in properly.

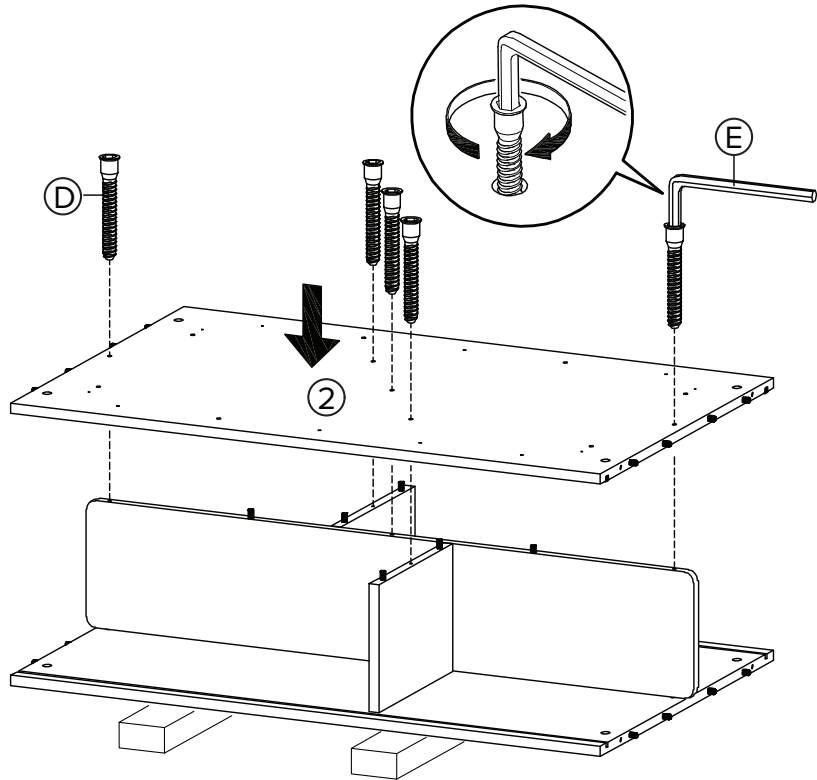

Step 6

Install 2 pieces of board No.3
to the side by inserting
camlock B into indicated holes
and tightening with Allen Key
E or a screw driver.

Please check the camlock B
placing orientation carefully in
the illustration.

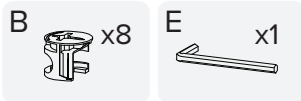
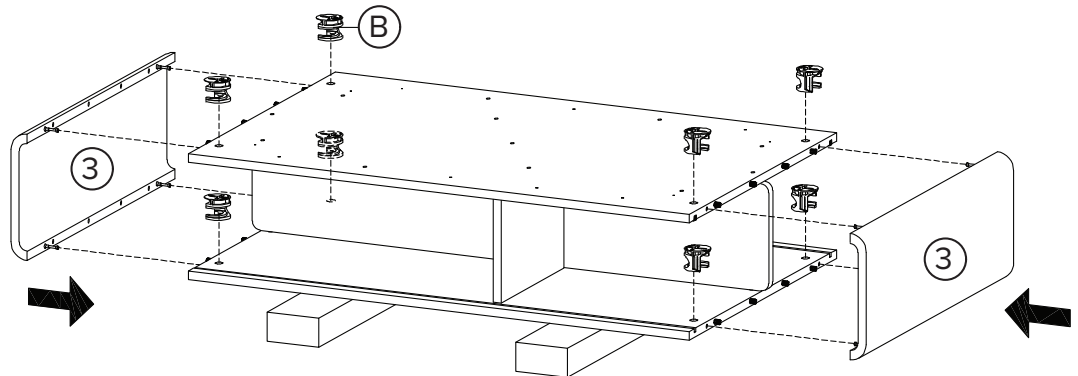
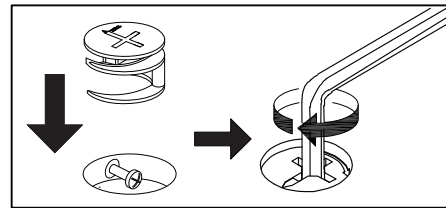

Step 7

Screw cambolt A into board No.2's indicated holes and tighten them with Allen key provided or a screw driver.

Please don't over screw or screw too deep.

*Don't screw too deep

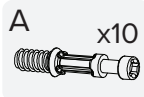
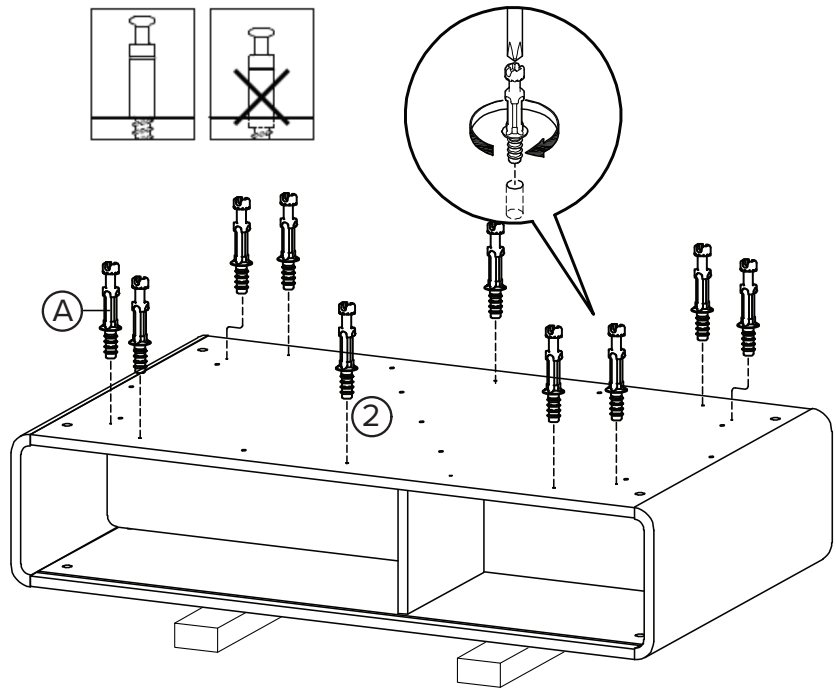

Step 8

Leg 8 and 9 are packed and connected together. Detach leg 8 and 9 by pulling the leg lightly, rotate it slightly if necessary.

Prepare leg No.8 (2pcs) and leg No.9 (2pcs) and plug in dowel C as indicated. Peel floor protector L and stick it to the tip of leg No.8 and No.9 as illustrated.

Prepare leg frame No.7 (2pcs) and install bracket G with screw H. Please check the illustration carefully for the bracket placing orientation.

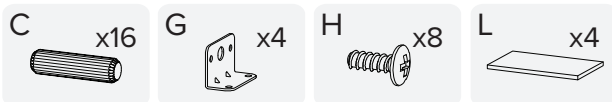
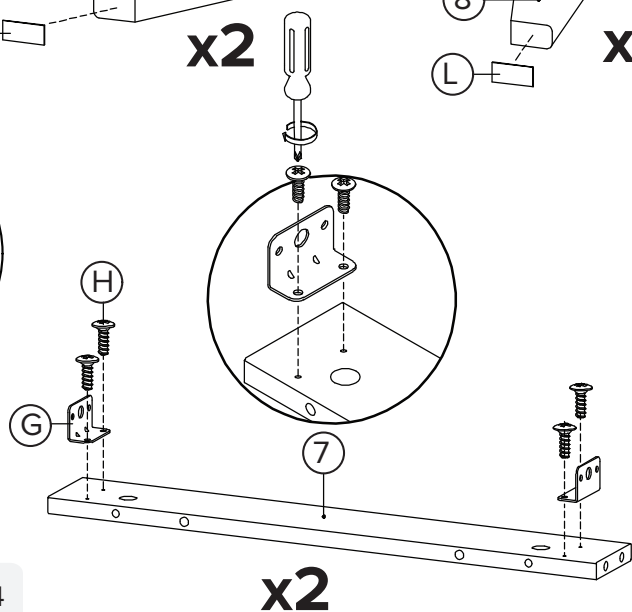
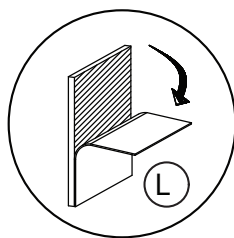
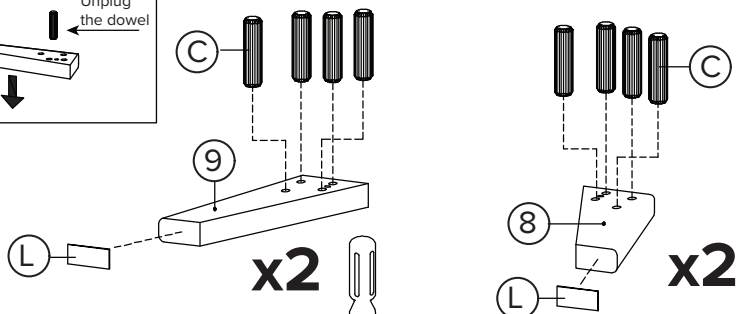
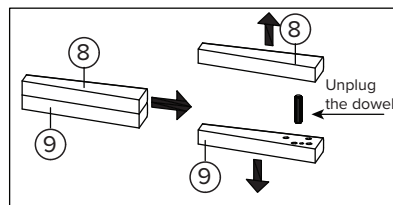

Step 9

Prepare leg frame No.6 and connect with 2 pieces of leg frame No.7 according to the position illustrated.

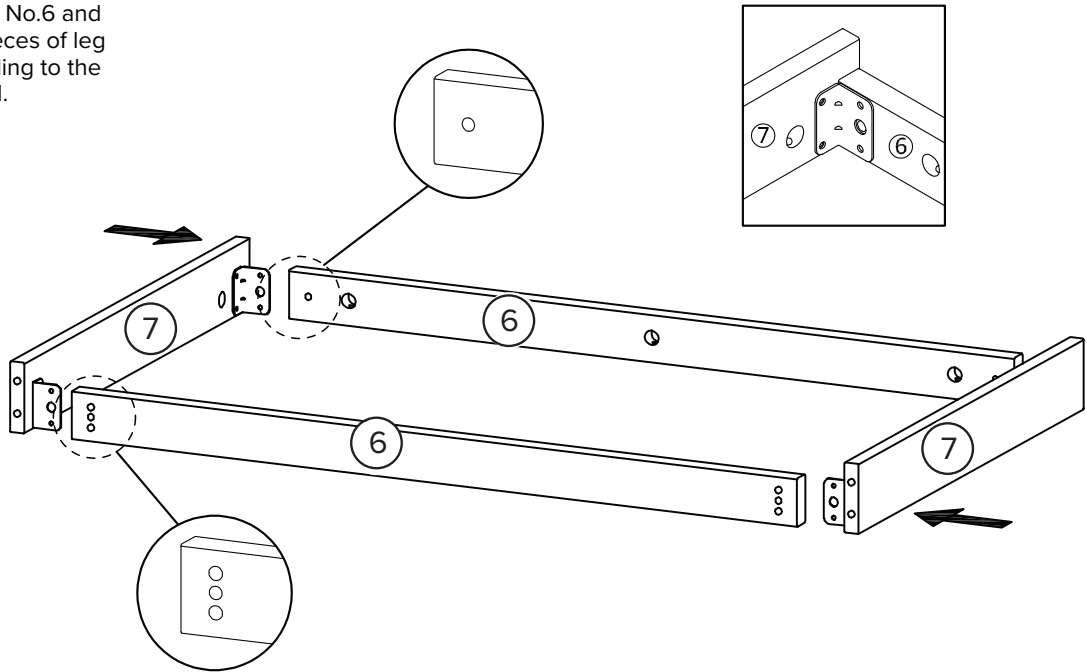

Step 10

Slot in leg No.8 (2pcs) and leg No.9 (2pcs) by matching the dowel position and inserting fully.

Please check carefully on leg No.8 and No.9's placement in the illustration.

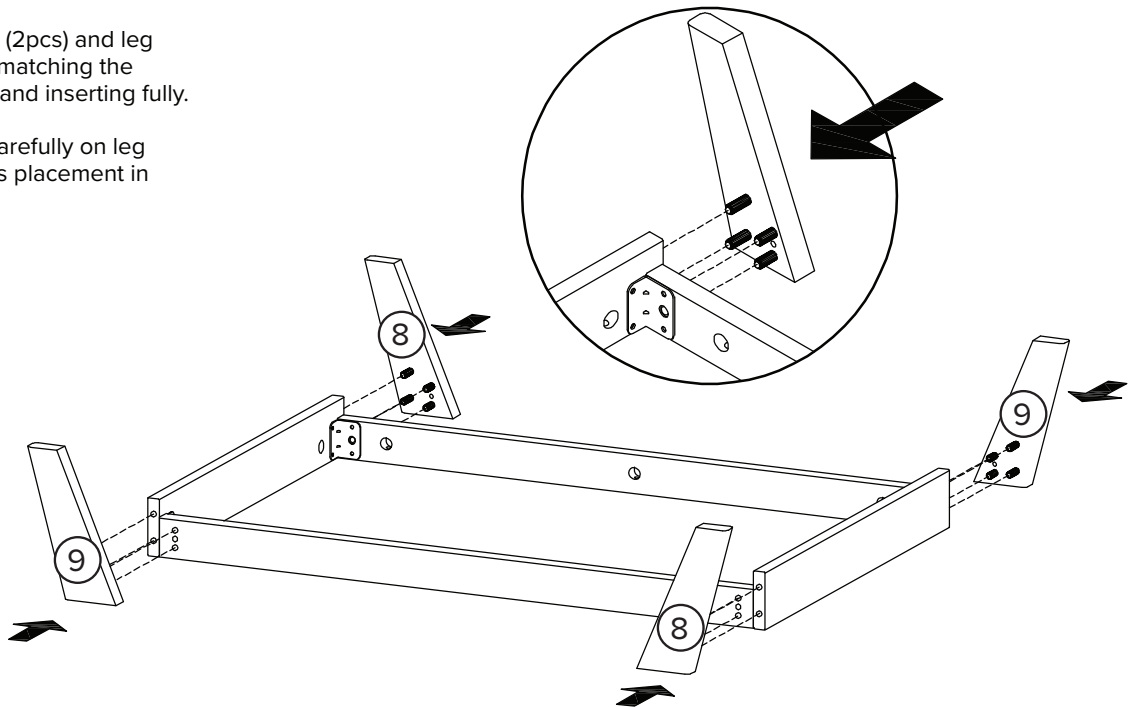

Step 11

Turn leg frame around carefully and let it stand on floor. You may require an extra pair of hands to complete this step.

Plug in dowel C into holes indicated in the illustration.

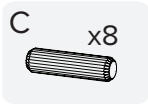
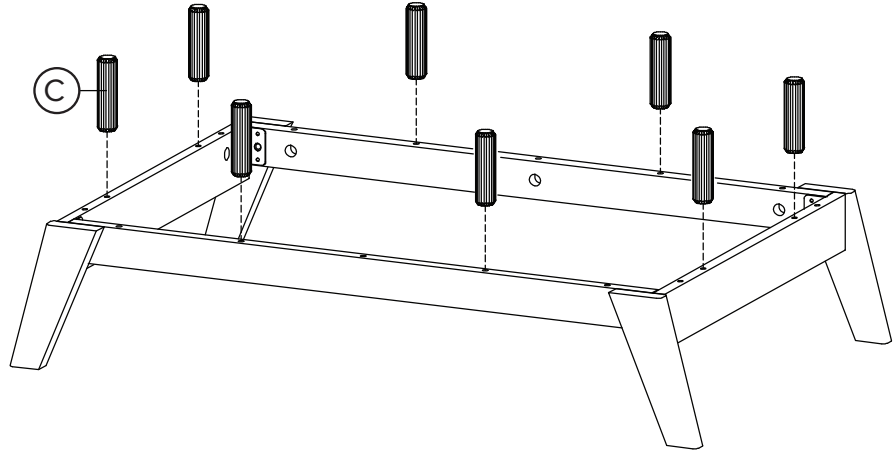

Step 12

With the extra hands, move leg frame upside down and install it to the table body board No.2. Engage all existing cambolt A on board No.2 and insert camlock B then tighten it. Please don't fully tighten until all cambolt and camlock are engaged.

Insert screw F into the bracket on leg frame and tighten the screw with Allen key to fix the leg.

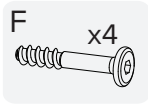
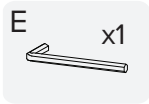
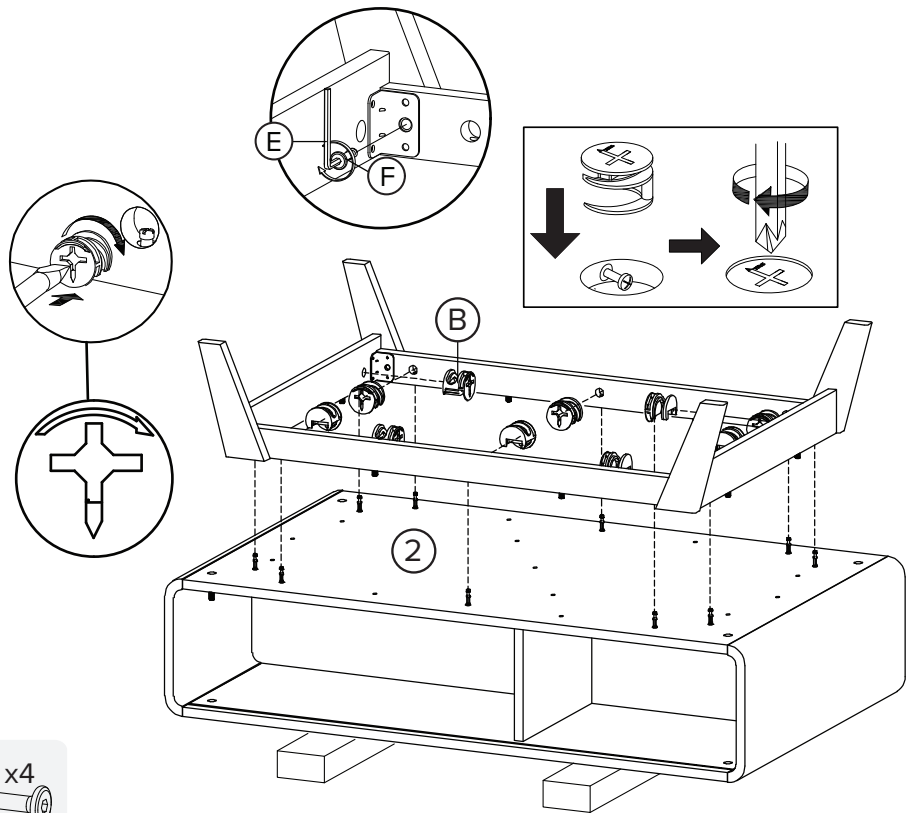

Step 13

Please check the illustration and identify the correct position of pin sliding. Pin sliding top J has a round shape pin, while pin sliding bottom K has a stripe shape pin.

Insert the pin and ensure pin sliding bottom K's stripe is aligned and parallel with the panel.

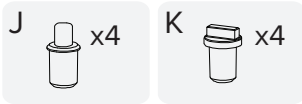
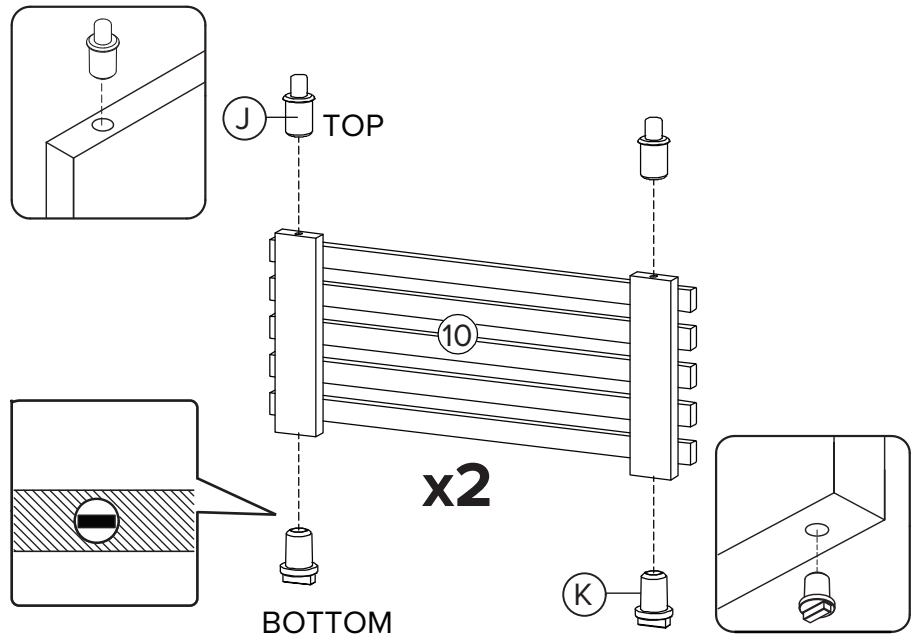

Step 14

Reverse the table body and let it stand upwards to install the sliding door.

Insert the door panel's top sliding pin to the groove underneath the top table board. While holding its position, insert the bottom sliding pin to the groove at the bottom board. When all pins are in the right position completely, release the door.

Peel buffer sticker and stick 1 piece to each side of the door panel, at the tip of the middle slat.

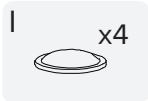
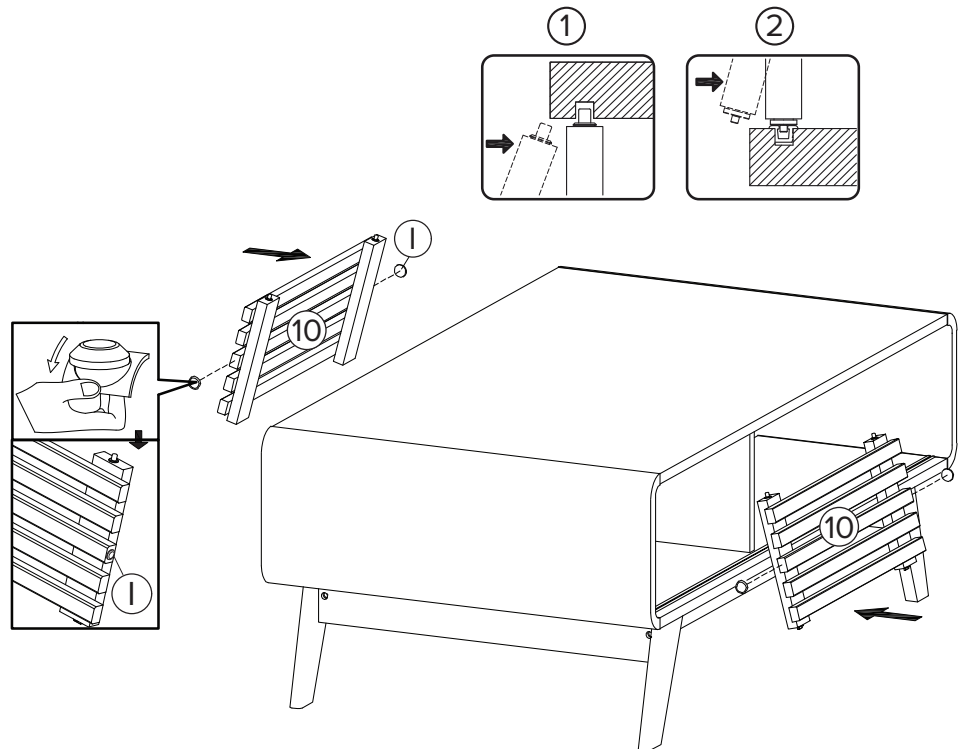

Finished!

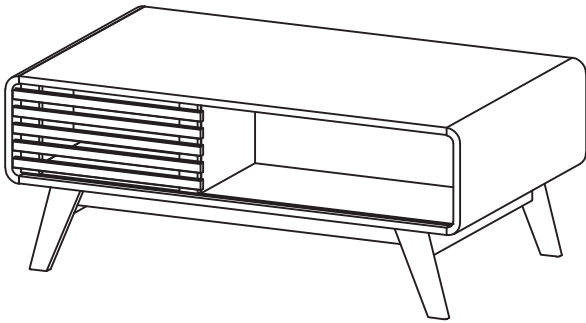

Congratulations! We're almost there! Please perform following checks to ensure assembly is properly done.

- Ensure there is no loose camlock or screw.
- Ensure the sliding door pin are properly engaged to the groove. Slide the door few times to ensure smooth sliding.
- Ensure all legs are fully tightened and floor protectors are attached to the leg ends.

Move your product carefully, with 2 people lifting it to the preferred location. Clean the product with a dry cloth. You are all set!

Enjoy your fresh and updated living space thanks to the addition of your new product!

Care

Instructions

Your furniture, if treated with respect and love, will last you a long time. Each piece requires light maintenance to maximize its longevity.

Few quick tips before using this product:

1. Recommended weight limit for the table top is 50lbs and 15lbs for each storage compartment.
2. Avoid uneven weight distribution for long time as it may cause damage to the product shape.
3. Sliding door might not slide smoothly when table is overloaded by weight.
4. Check and tighten the camlock and screw periodically as it may loose over the time.

How to take care of it?

1. Avoid direct sunlight or use curtains or blinds to limit the sun exposure to the product.
2. Clean the product regularly with a dry, soft cloth.
3. Avoid using abrasive or liquid cleanser.
4. We recommend always attaching the provided floor protector to the leg ends to protect your floor.
5. Avoid placing hot objects onto the table top surface.
6. Spillage may damage the surface. Clean immediately with a dry cloth.
7. We recommend using placemats or coasters underneath glasses, cups, bowls or plates to prevent scratches to the table surface.

Follow the care instructions and look after your furniture, in return, your furniture will look after you.

We hope to see you soon!

Frequently Asked Questions

1. What should I do if my product received is incomplete?

We are flat packed and come in separate boxes. Once your order has dispatched and been sent with Fedex, you will receive an email with tracking information. Please note that Fedex may deliver your boxes in separate deliveries. Kindly follow the tracking information, allowing all boxes to be received before starting assembly. If you need further assistance on deliveries tracking, feel free to reach out to us

2. What should I do if my shipment is damaged or products received are defective?

We're sorry to hear that! Please email us or chat with us and provide a detailed description of the damage, as well as photos (or videos, where appropriate) showing the damage. We will do our best to resolve the issue as soon as possible.

3. Who do I contact for repair queries?

You may write to us specifying your queries and we will be able to assist you further.

4. What warranty do you offer for your products?

You'll just need to submit your warranty registration upon receiving product. You can print a copy of your order from Order Details and upload it as your proof of purchase. More details can be found in **Warranty section**.

5. How do I claim my warranty?

Easy! Just email us and provide a detailed description of the fault as well as photos.

6. What should I do if I want to return the product?

We offer 30-day return policy upon product received. To initiate a return request, please message us through or contact our customer service team or with your reason of returning so we can facilitate the request and assist you further. For more details on the return policy, please refer to **Return section**.

1-Year Limited Warranty Information

Please read this limited warranty carefully. To ensure your warranty remains valid, you must comply with the following conditions. This warranty covers only manufacturing defects and does not include damages caused by misuse of the product.

Activate within 30 Days

Activate your warranty within 30 days of receiving the product

Warranty against manufacturing defects, starts from the date of receipt. A valid proof of purchase is required for warranty claims. The manufacturer's warranty and financial responsibility are applicable only to the products.

Proper Use Definition

Proper use means that the product was not abused by the User, according to the manufacturer's definition.

Inspection and Costs

The manufacturer requires inspection of the product to determine the warranty claim. Transportation or removal costs are the responsibility of the consumer.

Usage Conditions

The product should be used on a level surface where all legs touch the floor evenly, allowing even weight distribution. This warranty only covers replacement of legs and not any other parts.

Resolution of Claims

If a manufacturing defect occurs, the manufacturer will repair or replace the product at its discretion. The manufacturer reserves the right to substitute materials or models and cannot guarantee that replacement parts will match existing ones.