

1. Place the table top on top of the frame, place the Allen machine screws where the tabs are, and tighten with a wrench.

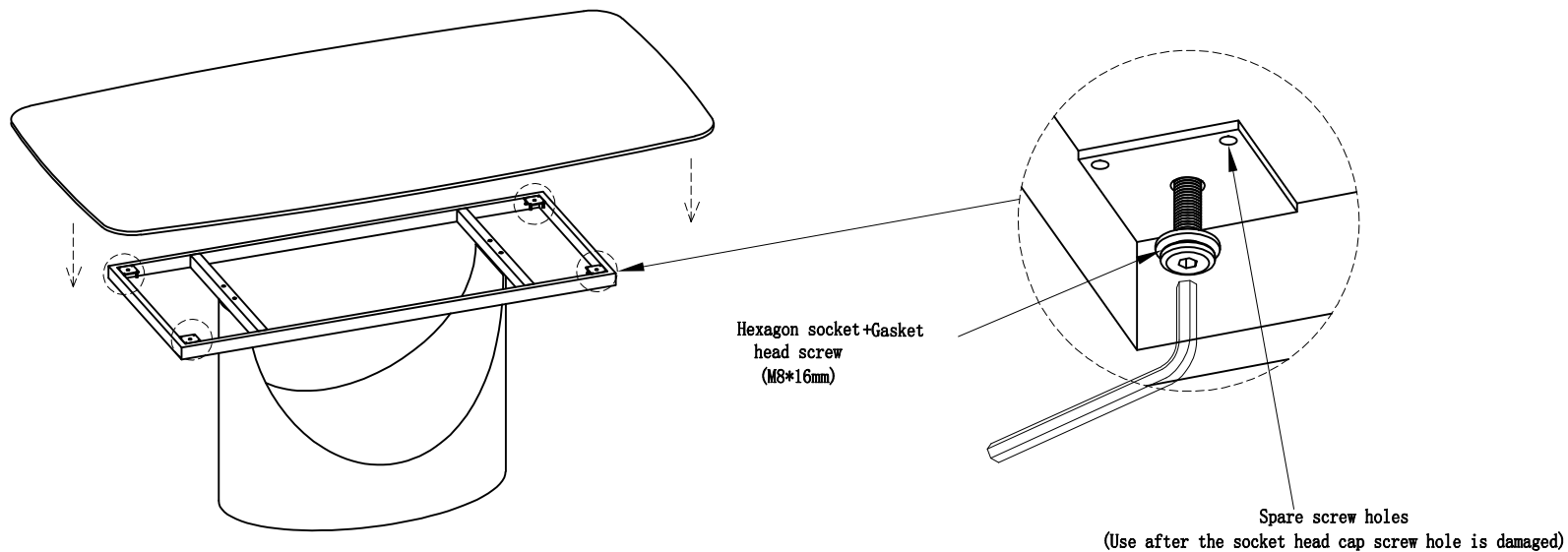

2. Installation finish.

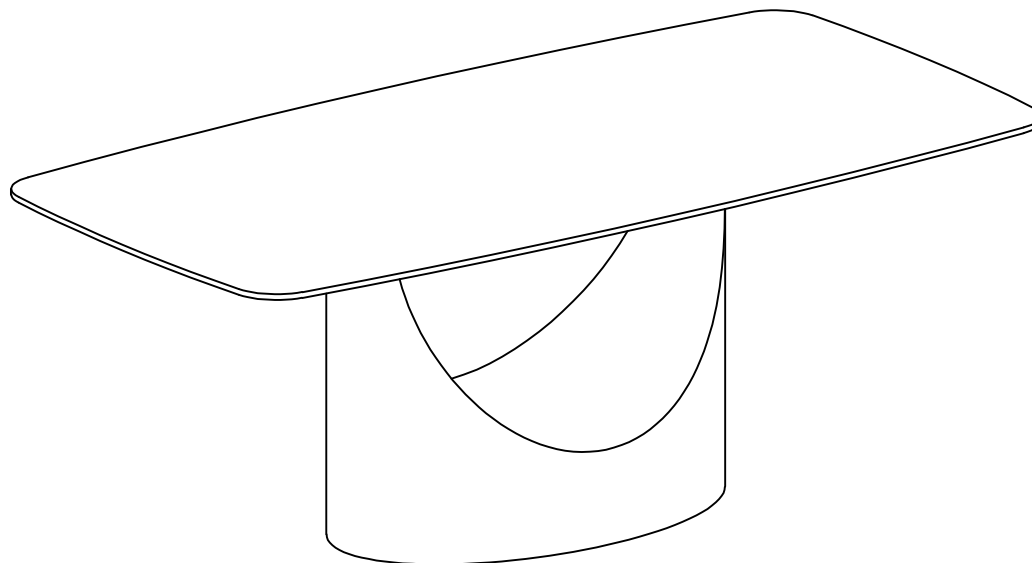

## Installation instruction

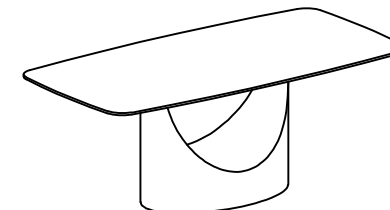

Installation  
Installation number: 2

- ① Please read the manual carefully before installing this product. And strictly follow the installation process
- ② Please take good care of this manual for your next installation

## Parts list

Serial number	Shape	Name	Quantity
A		Hexagon socket head screw (M8*16mm)	4
B		Gasket	4
C		Self-tapping screws (spare) (M4*16)	8