

Installation & Assembly

Cross-legged chairs

Chaises à pieds croisés

Stühle mit gekreuzten Beinen

Sedie a gambe incrociate

Sillas con patas cruzadas

あぐらをかいた椅子

盘腿椅

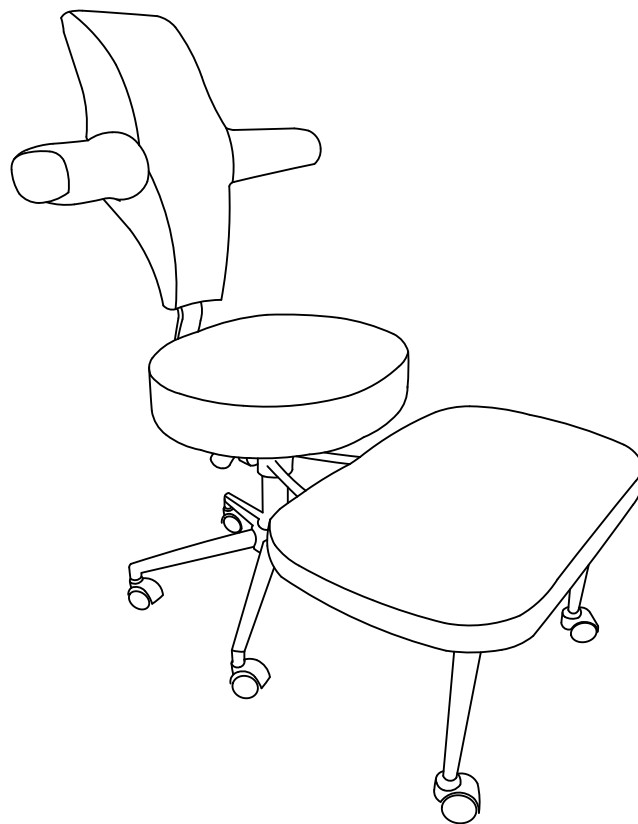

ASSEMBLY INSTRUCTION

Montageanleitung
Instructions De Montage
Istruzioni Per L'assemblaggio
Instrucciones De Montaje
組立説明書
安装说明书



HELPFUL HINTS

⚠ BEFORE YOU START

- Inspect product packaging to ensure the appearance is good.
- Read the assembly instruction carefully and follow it step by step.
- To avoid any scratching, putting a soft blanket on the floor is suggested.
- Identify, sort and count all the parts with tags.
- Find out installation position according to the drawing and install it in correct steps.



OTHER

- 1-2 people are required for assembly
- Estimated assembly time 3-5 minutes

⚠ CAUTION

- Be cautious when using a power drill or power screwdriver.
- Please be aware to slow down and stop when screw is nearly tight.
- Do Not use any harsh chemicals or abrasive cleaners for this item.
- Push, pull or drag this item carefully.

ASTUCES UTILES

⚠ AVANT DE COMMENCER

- Inspectez l'emballage du produit pour vous assurer que l'apparence est bonne.
- Lisez attentivement les instructions de montage et suivez-les étape par étape.
- Pour éviter toute rayure, posez une couverture douce sur le sol est suggéré.
- Identifiez, trie et comptez toutes les pièces avec des étiquettes.
- Trouver la position d'installation selon le dessin et l'installer dans les étapes correctes.



AUTRE

- Für die Montage werden 1-2 Personen benötigt
- Geschätzte Montagezeit 3-5 Minuten

⚠ AVERTIR

- Soyez prudent lorsque vous utilisez une perceuse électrique ou un tournevis électrique.
- Veuillez être conscient de ralentir et d'arrêter lorsque la vis est presque serrée.
- N'utilisez pas de produits chimiques corrosifs ou de nettoyeurs abrasifs pour cet article.
- Poussez, tirez ou tirez cet article avec précaution.

CONSEJOS ÚTILES

⚠ ANTES DE EMPEZAR

- Inspeccione el paquete del producto para asegurarse de que la apariencia es buena.
- Lea atentamente las instrucciones de montaje y sígalas paso a paso.
- Para evitar rayas, se sugiere poner una manta suave en el suelo.
- Identifique, clasifique y enumere todas las piezas con etiquetas.
- Averigüe la posición de instalación según el dibujo e instálela en los pasos correctos.



OTROS

- 1 à 2 personnes sont nécessaires pour l'assemblage
- Temps d'assemblage estimé 3 à 5 minutes

⚠ PRECAUCIÓN

- Tenga cuidado al utilizar un taladro eléctrico o un destornillador eléctrico.
- Tenga en cuenta que debe hacerlo más despacio y detenerse cuando el tornillo esté casi apretado.
- No utilice productos químicos agresivos ni limpiadores abrasivos para este artículo.
- Empuje, tire o arrastre este elemento con cuidado.

SUGGERIMENTI UTILI

⚠ PRIMA DI INIZIARE

- Controllare la confezione del prodotto per assicurarsi che sia in buono stato.
- Leggere con attenzione le istruzioni per l'assemblaggio e seguirle passo dopo passo.
- Per evitare graffi al pavimento, suggeriamo di stendervi una coperta morbida.
- Identificare, suddividere e contare tutte le parti con etichetta.
- Trovare la posizione adatta per il montaggio in base al disegno e montare lo scaffale seguendo correttamente i vari passaggi.



ALTRO

- Per il montaggio sono necessarie 1-2 persone
- Tempo stimato di montaggio 3-5 minuti

⚠ ATTENZIONE

- Prestare molta attenzione quando si utilizza un trapano elettrico o un cacciavite elettrico.
- Rallentare con accortezza e fermarsi quando una vite è già sufficientemente serrata.
- Non utilizzare prodotti chimici aggressivi o detergenti abrasivi su questo articolo.
- Spingere, tirare o trascinare questo articolo con cautela.

NÜTZLICHE HINWEISE

⚠ BEVOR SIE BEGINNEN

- Überprüfen Sie die Produktverpackung auf Schäden.
- Lesen Sie sich die Montageanleitung sorgfältig durch und befolgen Sie sie Schritt für Schritt.
- Um etwaiges Zerkratzen zu vermeiden, wird das Auslegen einer weichen Decke auf dem Boden empfohlen.
- Identifizieren, sortieren und zählen Sie alle Teile mit Tags nach.
- Identifizieren Sie die Montageposition gemäß der Zeichnung und bauen Sie das Regal den richtigen Schritten entsprechend auf.



SONSTIGES

- Se requieren 1-2 personas para el montaje.
- Tiempo estimado de montaje 3-5 minutos

⚠ VORSICHT

- Seien Sie bei der Verwendung einer Bohrmaschine oder eines Akkuschraubers vorsichtig.
- Bitte vergessen Sie nicht darauf, langsamer zu werden und zu stoppen, sobald die Schraube fast festgezogen ist.
- Verwenden Sie keinerlei aggressive Chemikalien oder scheuernden Reinigungsmittel für dieses Produkt.
- Schieben oder ziehen Sie dieses Produkt vorsichtig.

温馨提示

⚠ 安装前注意事项

- 检查产品包装，确保外观良好。
- 仔细阅读安装说明，按步骤操作。
- 为了避免刮伤，建议在地板上放一条柔软的毯子。
- 标识、分类和清点所有部件。
- 根据图形找到安装孔位，按正确步骤安装。



其他：

- 组装所需人员1-2人。
- 预计组装时间3-5分钟。

⚠ 注意：

- 小心使用电钻或电动螺丝刀。
- 当螺丝快要拧紧时，请注意减速
- 不要使用任何刺激性化学物质或擦洗涤剂。
- 当推、拉或拖动产品时，注意小心谨慎，防止损坏。

役に立つヒント

⚠ 組立の場所を確保し、順番通りに組み立てる

- 組立場所（充分広くて平たい場 所）を確保してください。
- 床や壁、商品を傷つけないように、商品の下に厚めの布や段ボールなどを敷いてください。
- 組立の順番を守らないと、組立できなくなったり、商品を傷つけたりします。



その他

- 組み立てには1~2人が必要です
- 組み立て時間の目安は3~5分です

⚠ 部品を確認する

- ネジ類などの部品番号、形状を説明書の部品一覧で確認してください。
- 部品をなくさないように纏めて置いてください。
- 部品を取り出すときに使う分だけ取り出してください。

DETAILS

DETAILS
DÉTAILS/POINTS DE MONTAGE
NOTE PARTICOLARI

DETALLES
組み立てのポイント
詳細情報

UNIT:INCH/CM/厘米

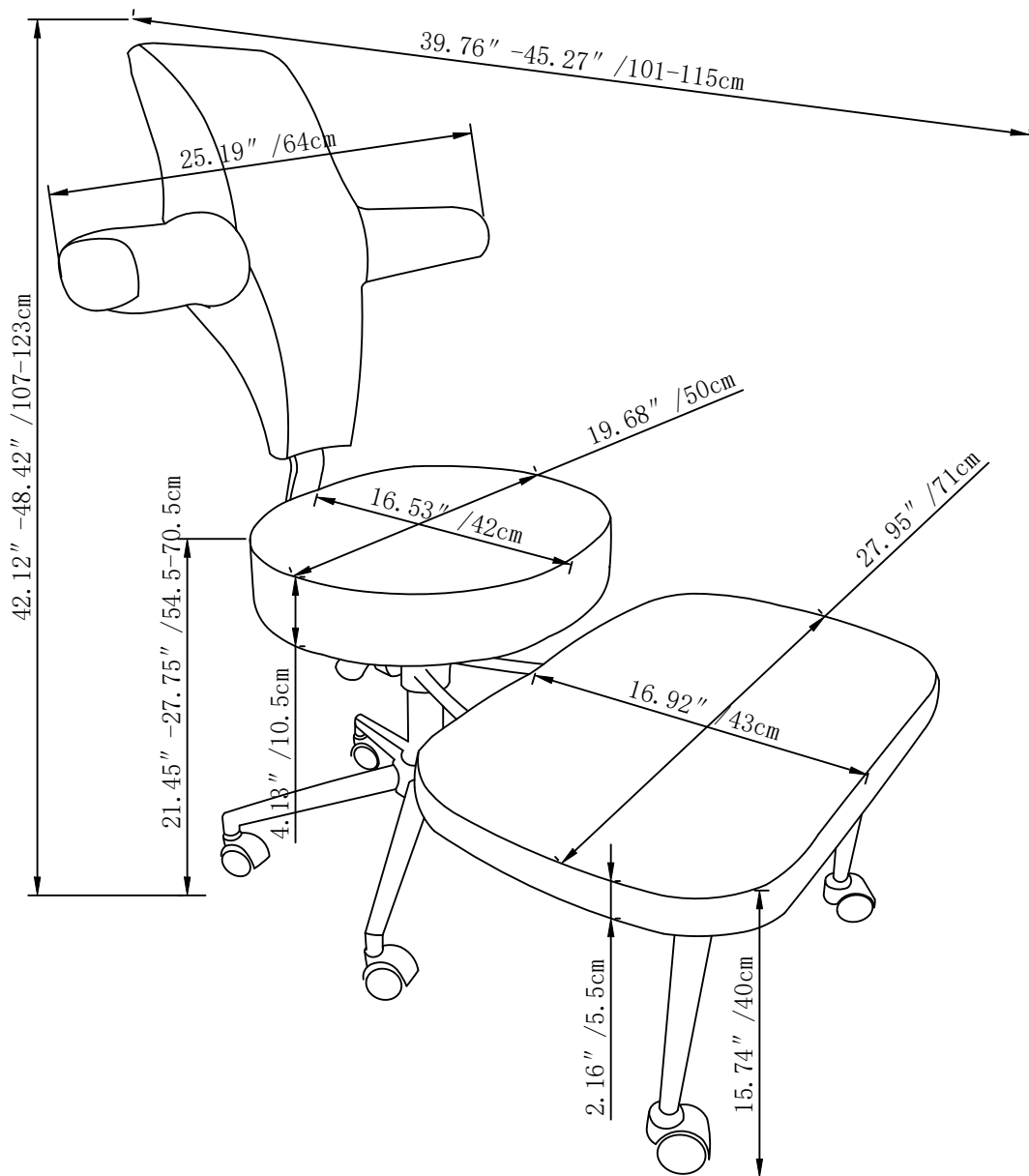

DETAILS

DETAILS
DÉTAILS/POINTS DE MONTAGE
NOTE PARTICOLARI



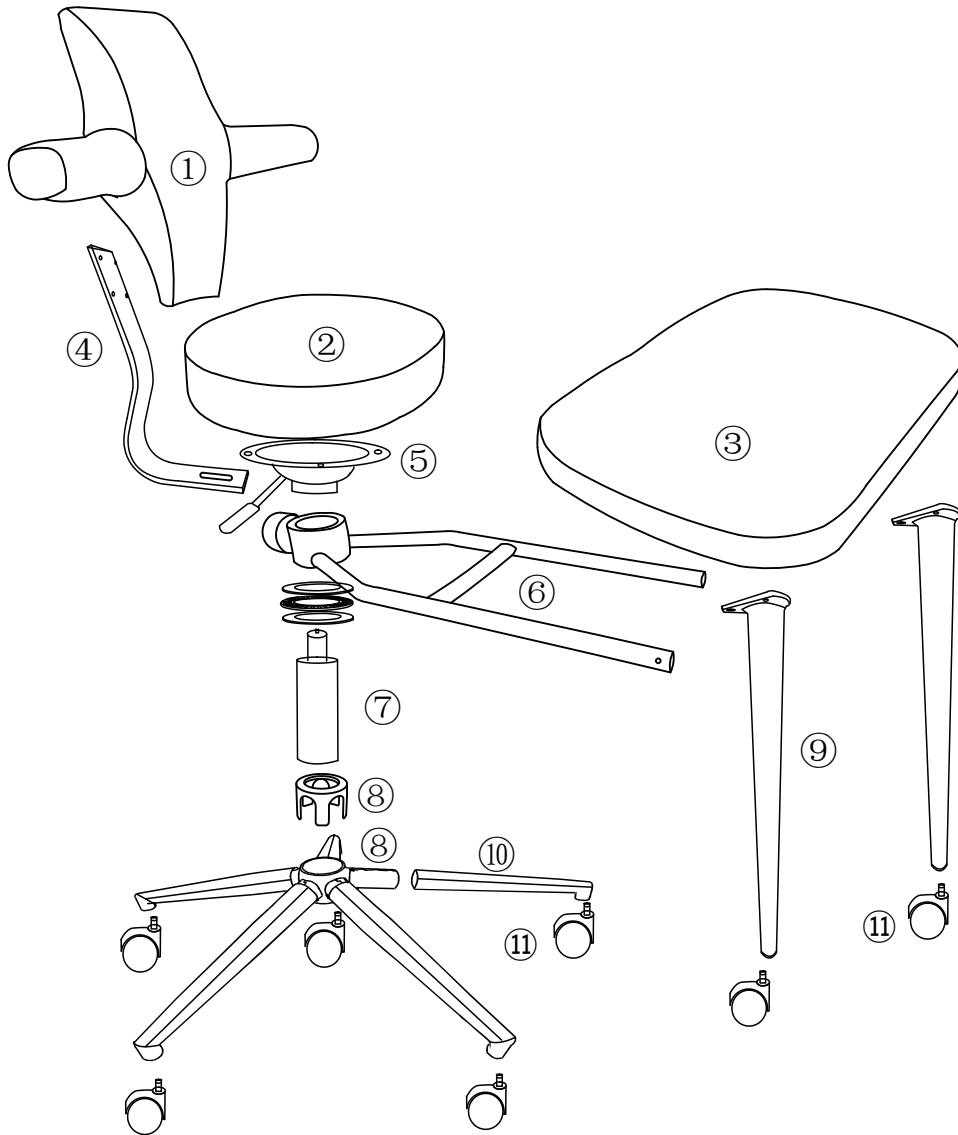



DETALLES
組み立てのポイント
詳細情報



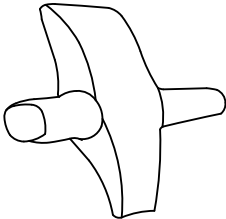
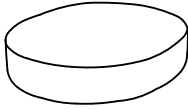
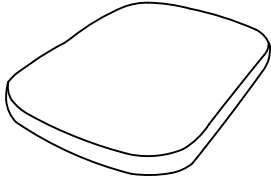
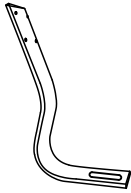
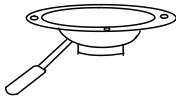
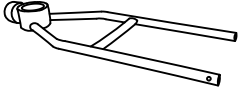

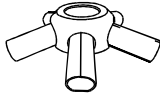
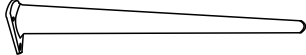
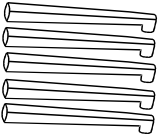

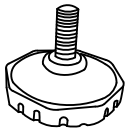

PART LIST

STÜCKLISTE
LISTE DES PIÈCES
ELENCO DEI PEZZI

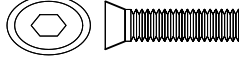
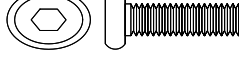
LISTA DE PIEZAS
部品の確認
部件清单

<p>①</p>  <p>X1</p>	<p>②</p>  <p>X1</p>	<p>③</p>  <p>X1</p>
<p>④</p>  <p>X1</p>	<p>⑤</p>  <p>X1</p>	<p>⑥</p>  <p>X1</p>
<p>⑦</p>  <p>PLEASE REMOVE</p> <p>X1</p>	<p>⑧</p>  <p>X1</p>	<p>⑨</p>  <p>X2</p>
<p>⑩</p>  <p>X1</p>	<p>⑪</p>  <p>X7</p>	<p>⑫</p>  <p>X1</p>
<p>⑬</p>  <p>X1</p>	<p>⑭</p>  <p>X2</p>	

ACCESSORY LIST			ZUBEHÖRLISTE LISTE DES ACCESSOIRES ELENCO DEGLI ACCESSORI	LISTA DE ACCESORIOS 付属品部品の確認 配件清單
A	M6*14mm	10+1		
B	M6*18mm	6+1		
C	杯头螺丝M5*8mm	2+1		
D	沉头螺丝M6*25mm	4+1		
E	M6*20mm	4+1		
F	M6*25mm	8+1		
G	M6	1		
H	Ø46	1		

1

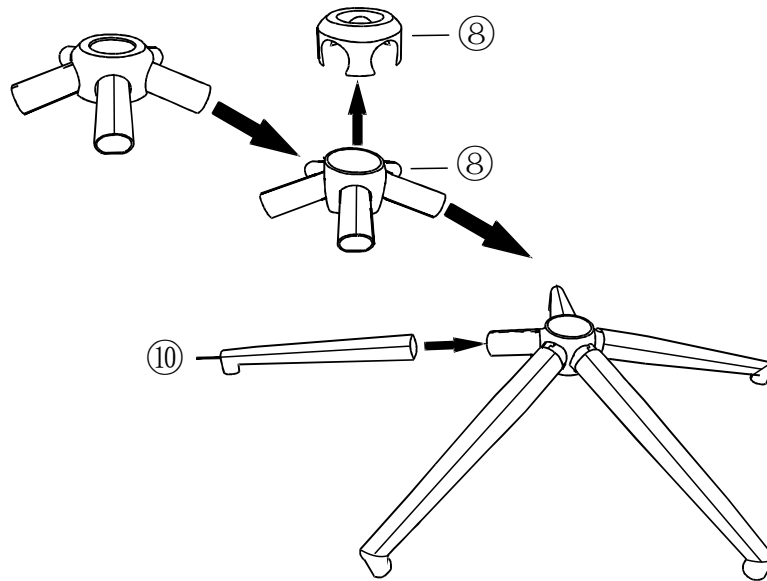

2

- ※Fully tighten all screws.
- ※Serrez complètement toutes les vis.
- ※Ziehen Sie alle Schrauben vollständig an.
- ※Serrare completamente tutte le viti.
- ※Apriete a tope los tornillos.
- ※すべてのネジをしっかり締める。
- ※锁紧全部螺丝

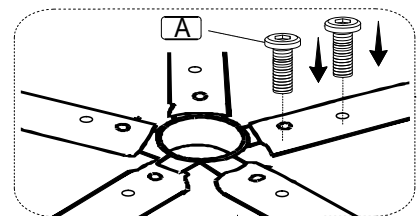
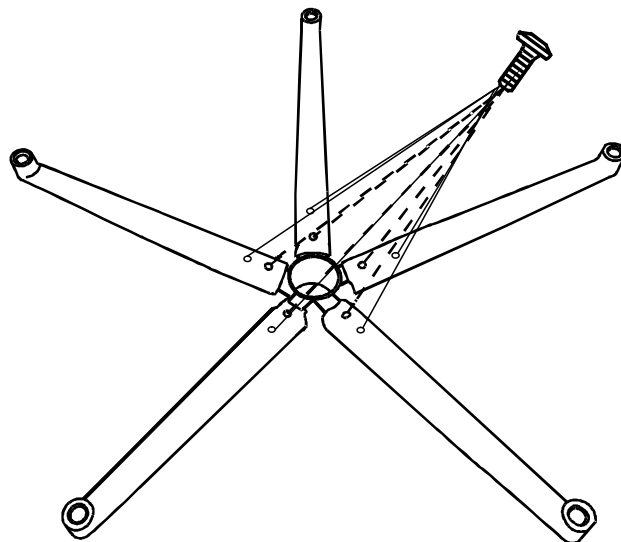

A

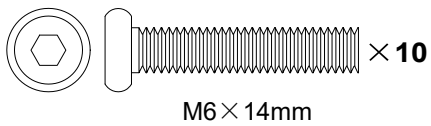

M6 x 14mm

G



3

As shown in the picture: The air rod can be used normally only after the air rod cap is removed.

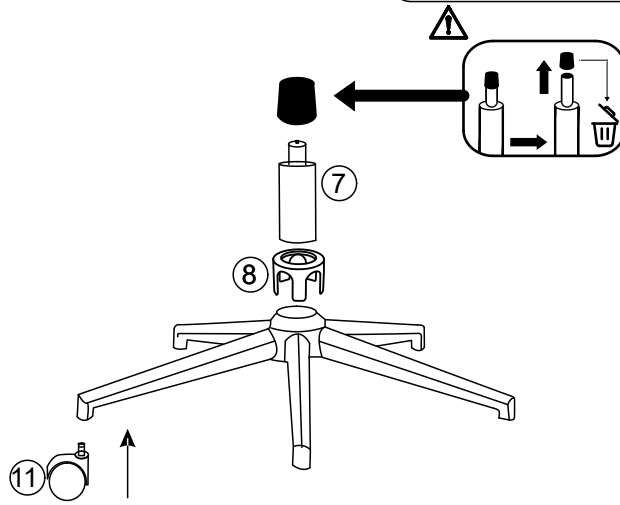

4

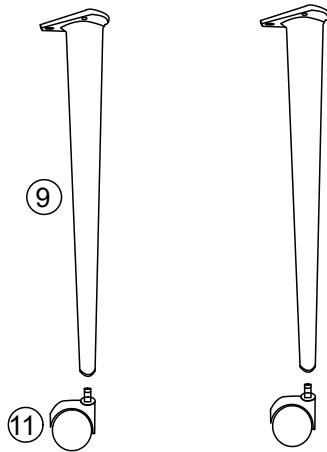

5

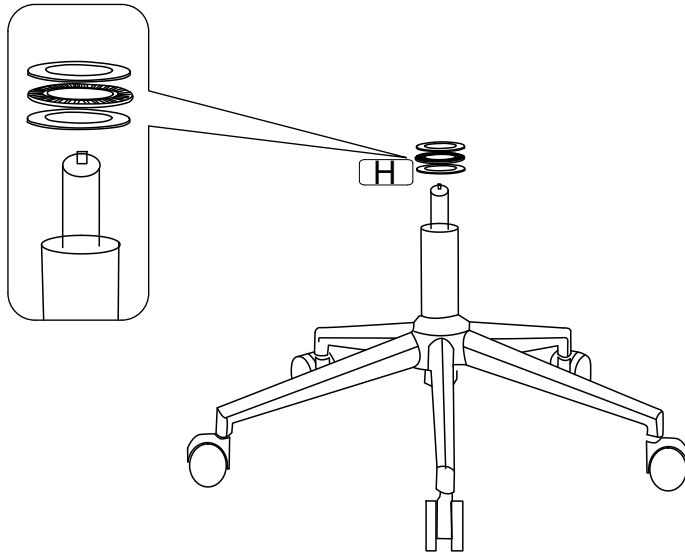

6

※Fully tighten all screws.
 ※Serrez complètement toutes les vis.
 ※Ziehen Sie alle Schrauben vollständig an.
 ※Serrare completamente tutte le viti.
 ※Apriete a tope los tornillos.
 ※すべてのネジをしっかり締める。
 ※锁紧全部螺丝

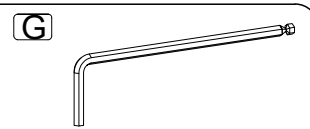
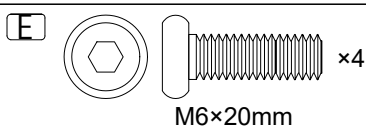
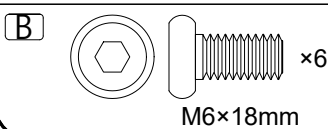
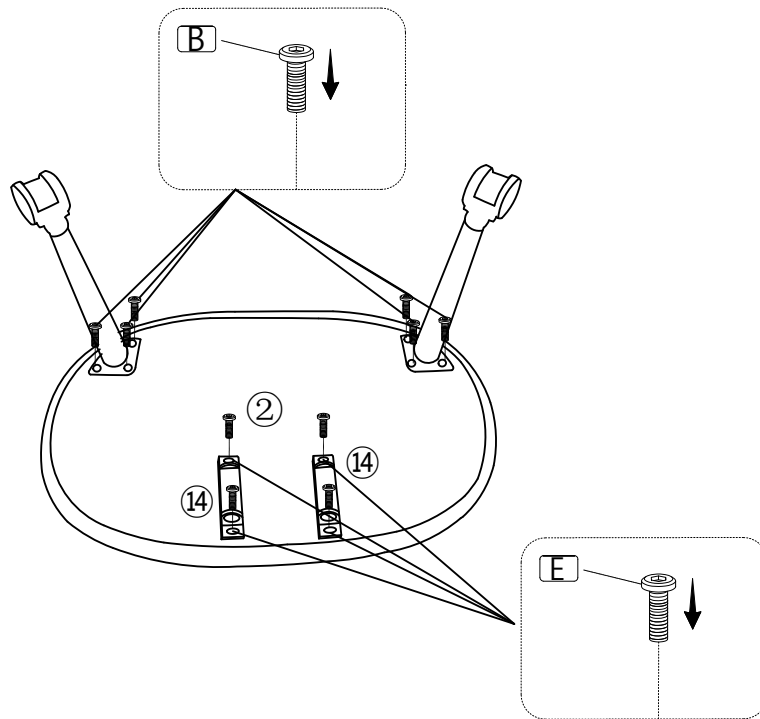

5

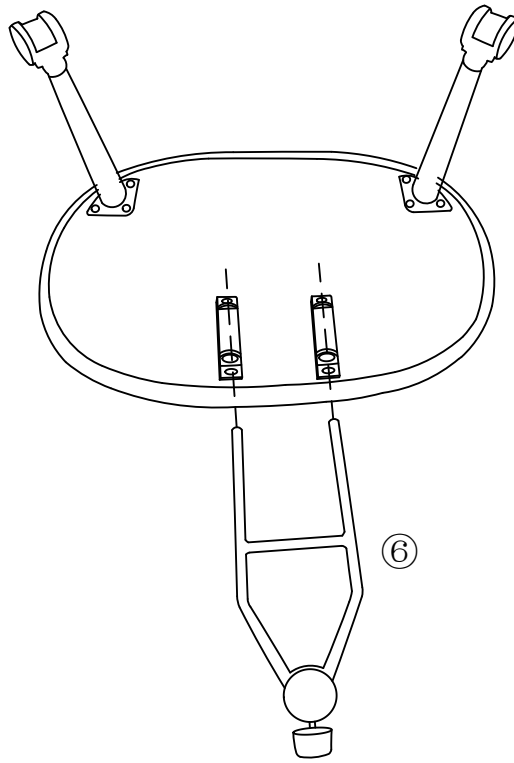

6

※Fully tighten all screws.
 ※Serrez complètement toutes les vis.
 ※Ziehen Sie alle Schrauben vollständig an.
 ※Serrare completamente tutte le viti.
 ※Apriete a tope los tornillos.
 ※すべてのネジをしっかり締める。
 ※锁紧全部螺丝

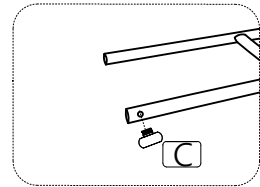
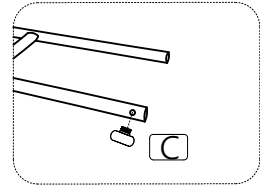
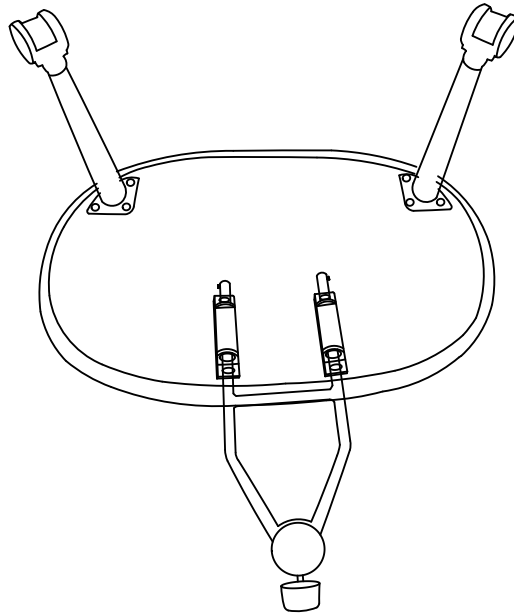

C

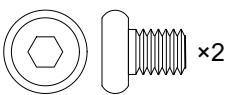

杯头螺丝M5*8mm

G



7

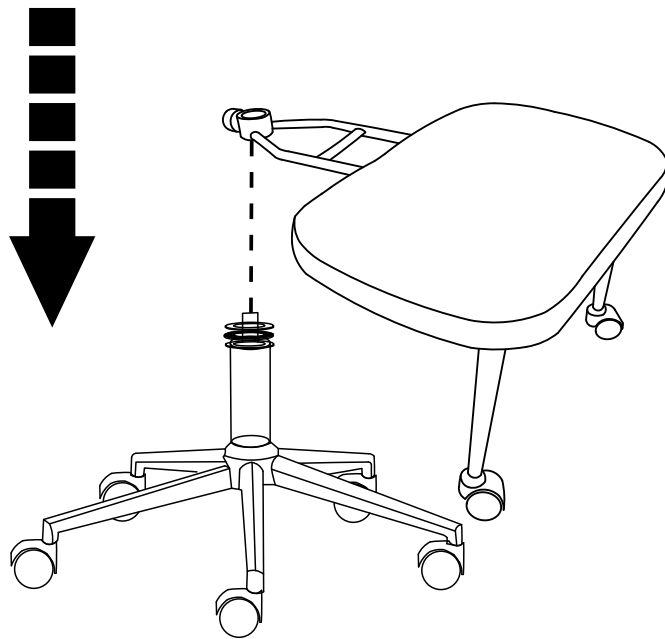

8

- ※Fully tighten all screws
- ※Serrez complètement toutes les vis
- ※Ziehen Sie alle Schrauben vollständig an
- ※Serrare completamente tutte le viti
- ※Apriete a tope los tornillos
- ※すべてのネジをしっかり締める。
- ※锁紧全部螺丝

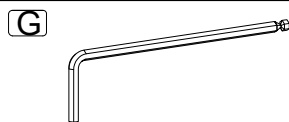
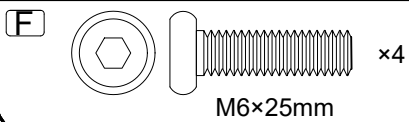
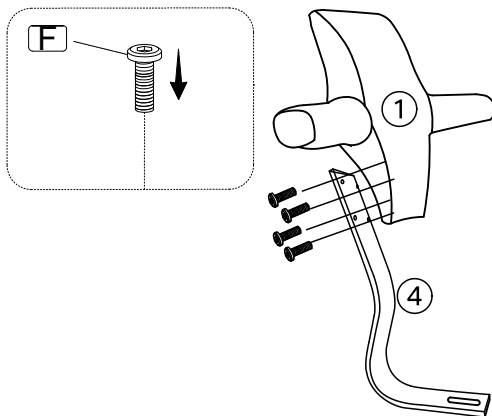

9

80% tighten
 80 % serré
 80% festziehen
 Serraggio al 80%
 80 % reforzado
 80%締め付け
 80%锁紧

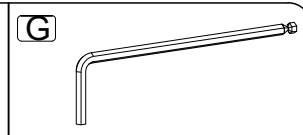
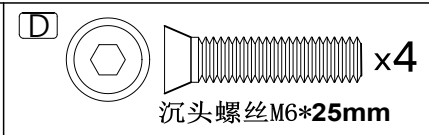
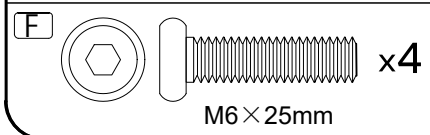
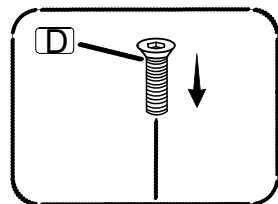
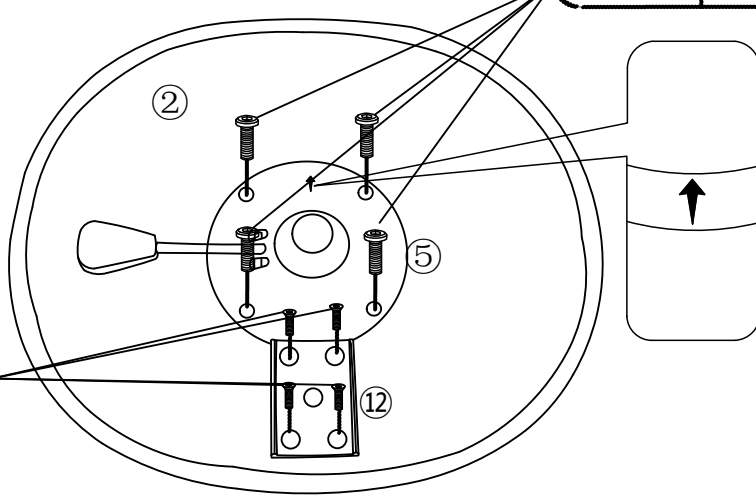
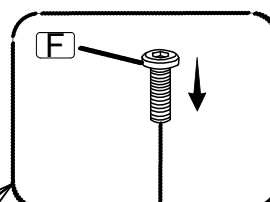

10

※Fully tighten all screws
 ※Serrez complètement toutes les vis
 ※Ziehen Sie alle Schrauben vollständig an
 ※Serrare completamente tutte le viti
 ※Apriete a tope los tornillos
 ※すべてのネジをしっかり締める。
 ※锁紧全部螺丝

✗ **Incorrect installation sequence:**
 Install the back connecting iron first and then the tray,
 resulting in the failure to install the tray.

✓ **Correct installation sequence:**
 Install the tray first and then the back connecting iron.

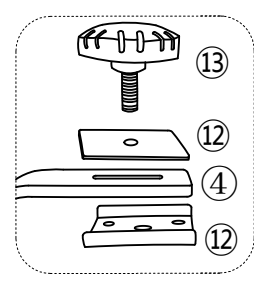
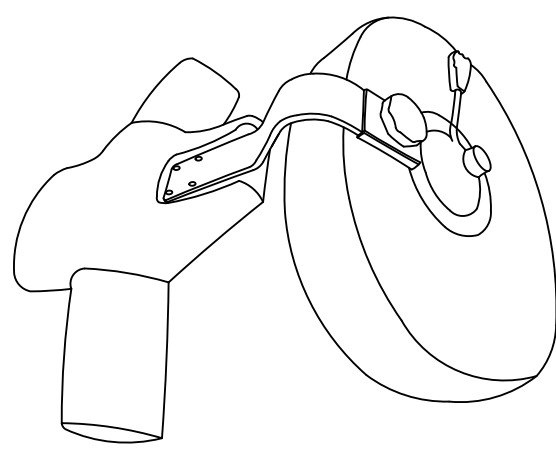

11

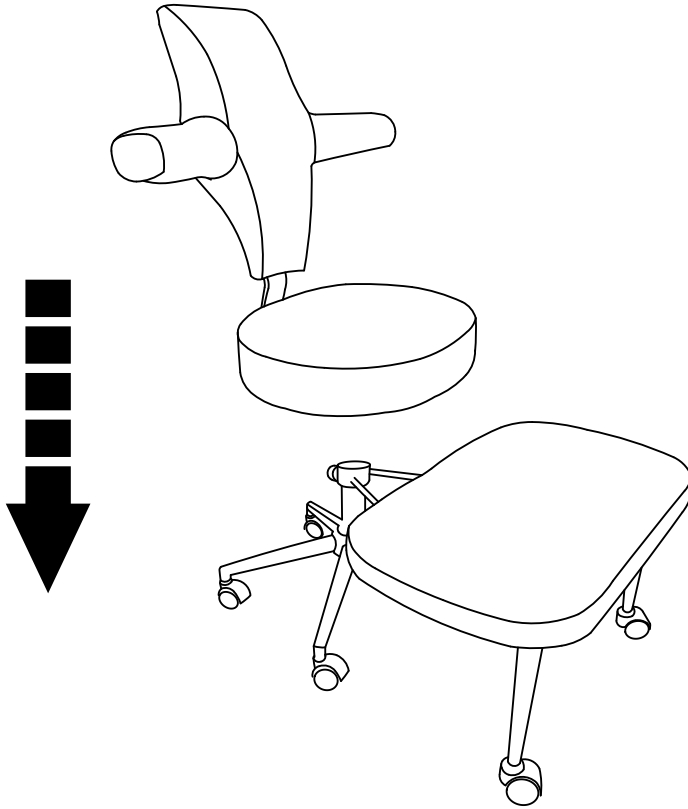

12

