

ASSEMBLY INSTRUCTIONS

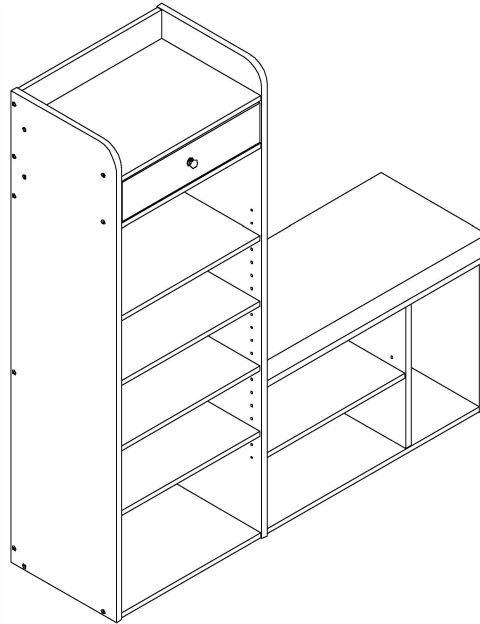









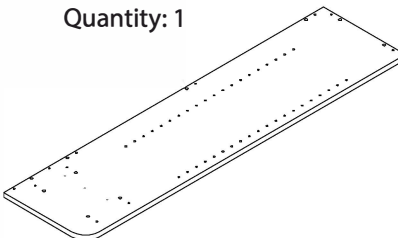
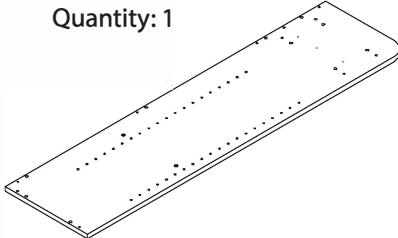
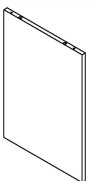
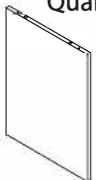





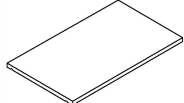
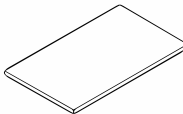
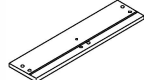



SHOE RACK

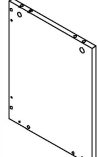

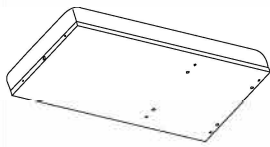
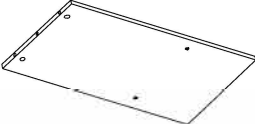



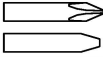





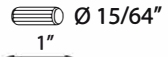

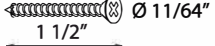

NOTE TO CUSTOMERS:

- For ease and speed of assembly we recommend that before you commence each step of the assembly that you identify all the parts required to complete that step.
- We recommend that where possible you allow sufficient space to assemble the item as close as possible to the place where it will be once assembled.
- For the protection of your furniture we recommend that the product is placed on a dry, soft, smooth and clean surfaces during assembly to prevent any damage. Avoid damp and direct sunlight.
- During assembly do not over tighten the screws or bolts, as this may damage the product.
- Please ensure you retain all the product packaging until the item is completely assembled.
- Periodically check all fitting and re-tighten as necessary.
- Never allow any liquids to remain on your furniture as absorption can cause the wood to warp or finish to de-laminate.
- It is recommended that this item should be assembled by two adults.

PARTS IDENTIFICATION

<p>P1 Quantity: 1</p>  <p>Long Vertical Panel (left)</p>		<p>P2 Quantity: 1</p>  <p>Long Vertical Panel (middle)</p>		<p>P3 Quantity: 1</p>  <p>Top Panel</p>
<p>P4 Quantity: 2</p>  <p>Base panel</p>	<p>P5 Quantity: 1</p>  <p>Upper Back Panel</p>	<p>P6 Quantity: 1</p>  <p>Upper Back Rail</p>	<p>P7 Quantity: 1</p>  <p>Middle Back Rail</p>	<p>P8 Quantity: 1</p>  <p>Lower Back Rail</p>
<p>P9 Quantity: 1</p>  <p>Middle Lower Back Rail</p>	<p>P10 Quantity: 4</p>  <p>Shelf Panel (left)</p>	<p>P11 Quantity: 1</p>  <p>Shelf Panel (center)</p>	<p>P12 Quantity: 1</p>  <p>Drawer Front Panel</p>	<p>P13 Quantity: 1</p>  <p>Drawer Left Panel</p>
<p>P14 Quantity: 1</p>  <p>Drawer Right Panel</p>	<p>P15 Quantity: 1</p>  <p>Drawer Back Panel</p>	<p>P16 Quantity: 1</p>  <p>Drawer Bottom</p>	<p>P17 Quantity: 1</p>  <p>Drawer Support Bar</p>	<p>P18 Quantity: 1</p>  <p>Side Panel (right)</p>
<p>P19 Quantity: 1</p>  <p>Divider Panel</p>	<p>P20 Quantity: 1</p>  <p>Seat Panel with Seat Cushion</p>	<p>P21 Quantity: 1</p>  <p>Base Panel</p>	<p>P22 Quantity: 1</p>  <p>Right Upper Back Rail</p>	<p>P23 Quantity: 1</p>  <p>Right Lower Back Rail</p>
<p>P24 Quantity: 1</p>  <p>Middle Upper Back Rail</p>	<p>Tools required:</p>  Mallet  Household Screwdriver			 <p>This item requires two adult persons to assemble it</p>

HARDWARE LIST

<p>H1 Wooden Dowel M6 x 25 Ø 15/64" 1"</p>  <p>Quantity: 37 pcs</p>	<p>H2 Connecting Bolts</p>  <p>Quantity: 13 pcs</p>	<p>H3 Cam Lock 15 x 9.5mm</p>  <p>Quantity: 10 pcs</p>	<p>H4 Cam Lock 12 x 9.5mm</p>  <p>Quantity: 3 pcs</p>	<p>H5 Screw M4 x 12. 15/32" Ø 5/32"</p>  <p>Quantity: 12 pcs</p>
<p>H6 Drawer slide</p>  <p>Quantity: 1 set</p>	<p>H7 Screw #9 x 1 1/2" Ø 11/64" 1 1/2"</p>  <p>Quantity: 38 pcs</p>	<p>H8 Shelf support pin</p>  <p>Quantity: 20 pcs</p>	<p>H9 Drawer Pull</p>  <p>Quantity: 1 pc</p>	<p>H10 Screw Pan Head for Pull #6 x 16.5 41/64" Ø 9/64"</p>  <p>Quantity: 1 pc</p>
<p>H11 Colored Sticker</p>  <p>Quantity: 25 pcs</p>	<p>H12 Anti-tip web strip</p>  <p>Quantity: 2 pcs</p>	<p>H13 Screw for anti-tip M3.5 x 12 5/32" Ø 9/64"</p>  <p>Quantity: 2 pcs</p>	<p>H14 Screw for mount to wall #6 x 1 1/4" 1 1/4" Ø 9/64"</p>  <p>Quantity: 2 pcs</p>	<p>H15 Wall plug for Screw H14</p>  <p>Quantity: 2 pcs</p>

STEP 1 Insert wooden dowels (H1) into the following parts.

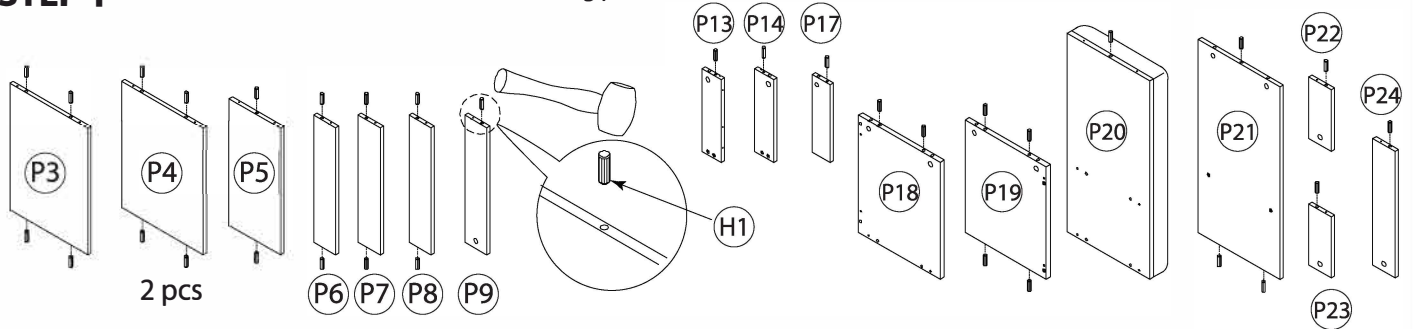

STEP 2 Align the Connecting Bolt (H2), use a household Philip Screwdriver to drive the bolt until it is snug.

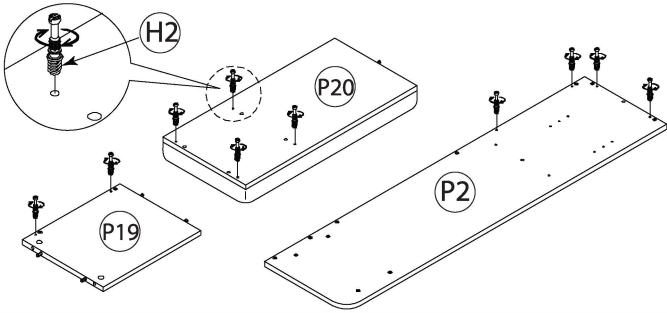

STEP 3 Install a part of the Drawer Slide (H6), to the Long Vertical Panel (P1) & (P2), use a household Philip Screwdriver to drive the bolt until it is snug.

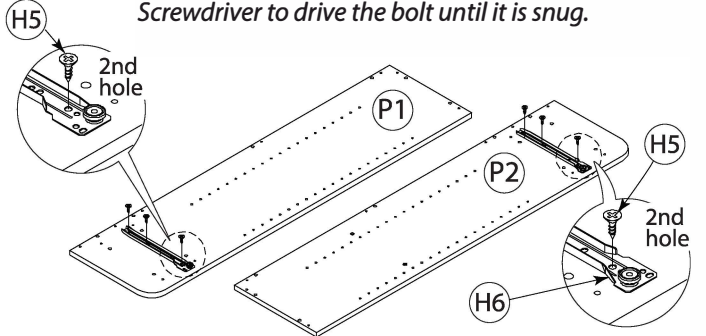

STEP 4

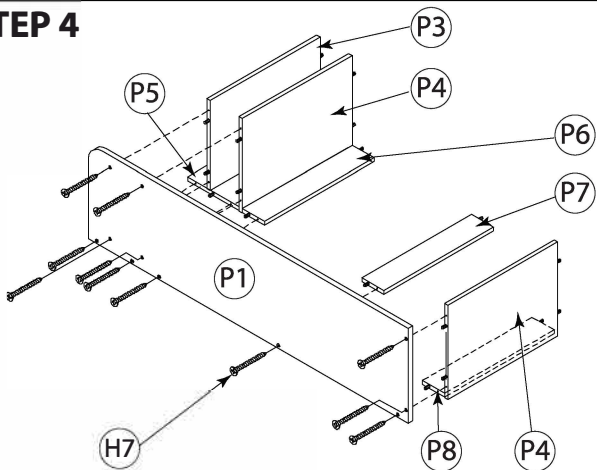

STEP 5

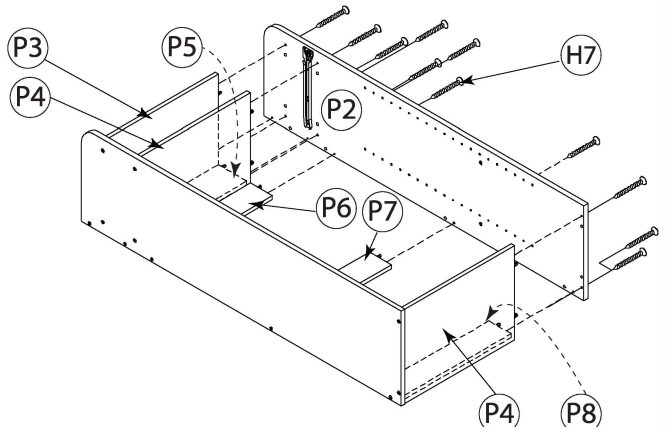

STEP 6

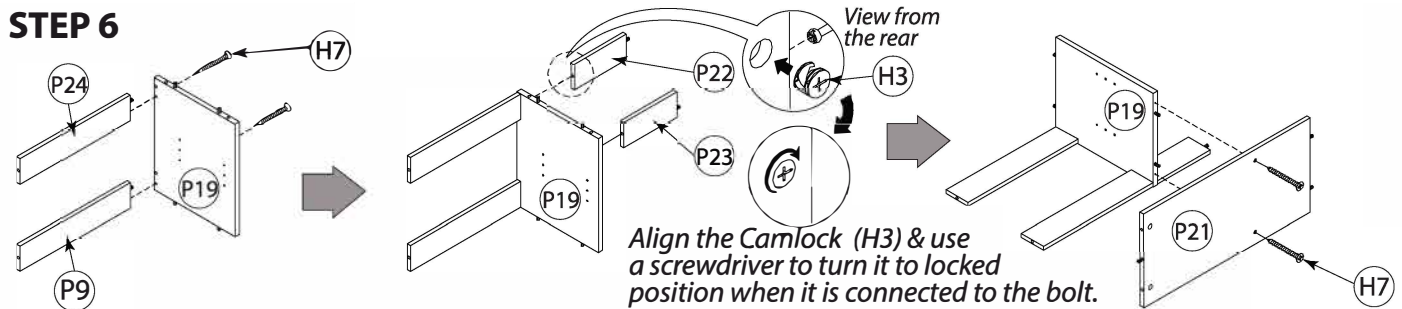

STEP 7

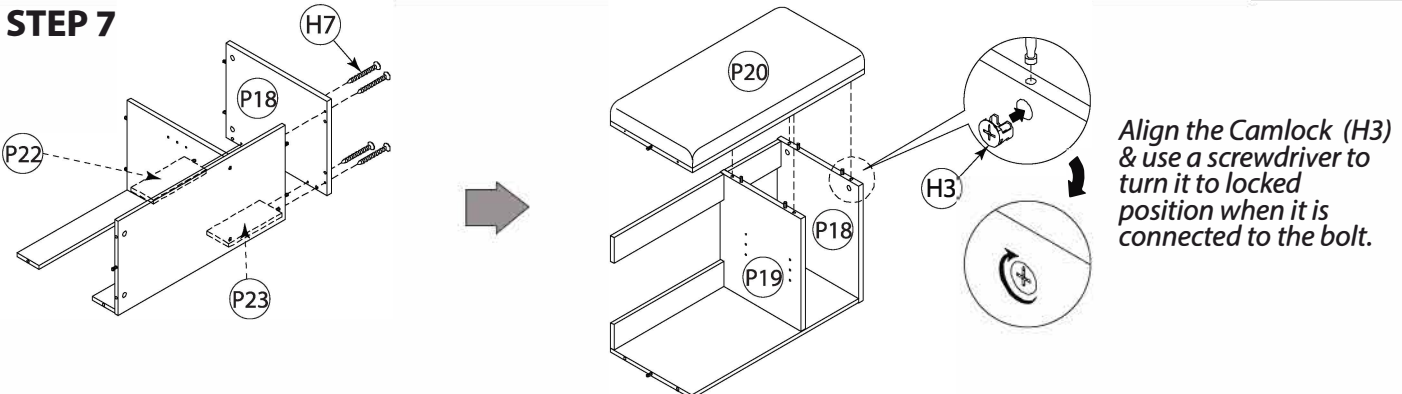

STEP 8

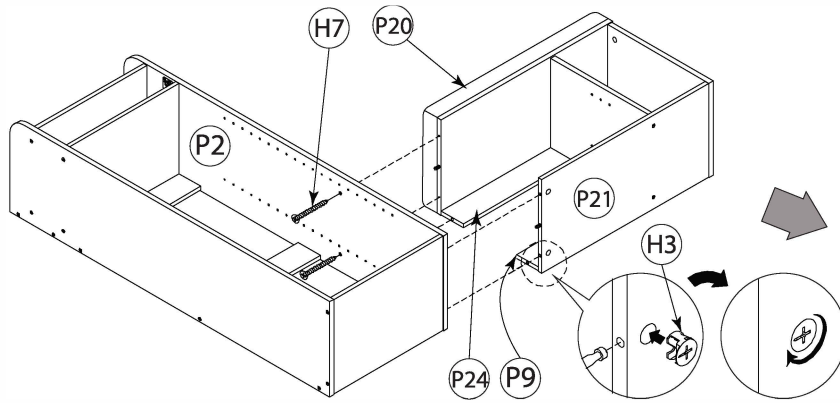

Align the Camlock (H3) & use a screwdriver to turn it to locked position when it is connected to the bolt.

STEP 9

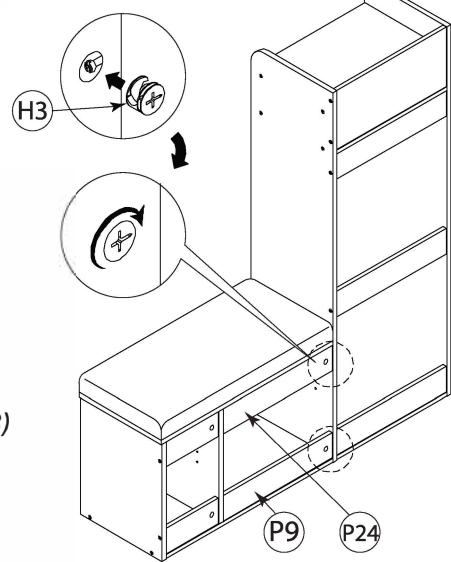

STEP 10 Assemble the Drawer

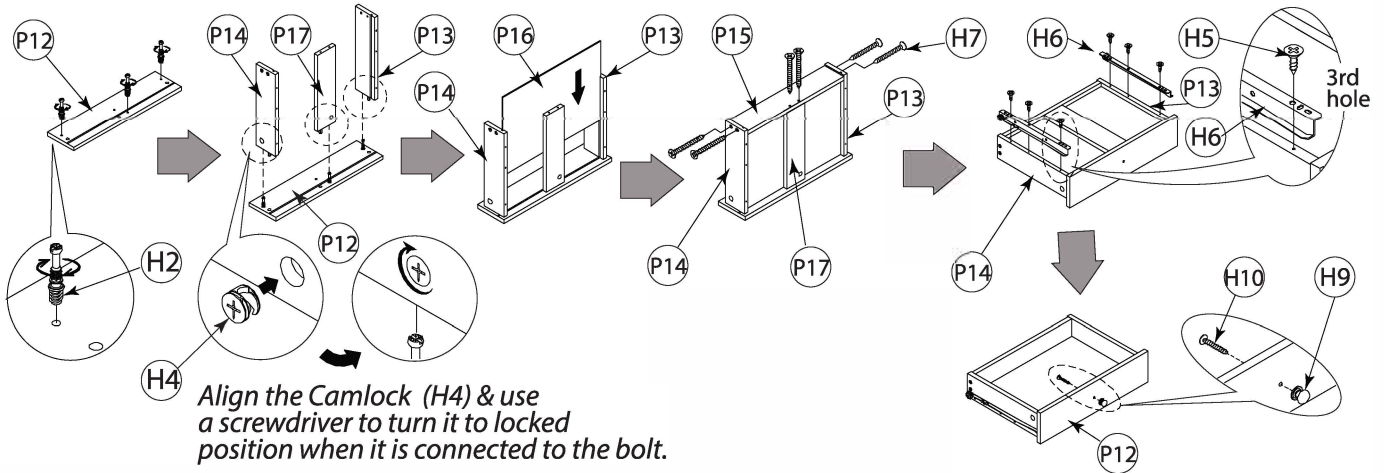

Align the Camlock (H4) & use a screwdriver to turn it to locked position when it is connected to the bolt.

STEP 11

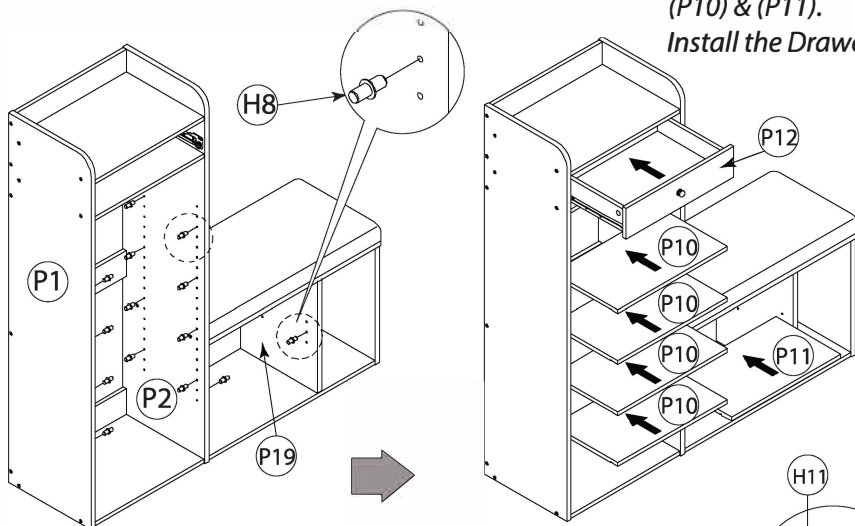

Place all the Shelf Panels (P10) & (P11).
Install the Drawer

STEP 12

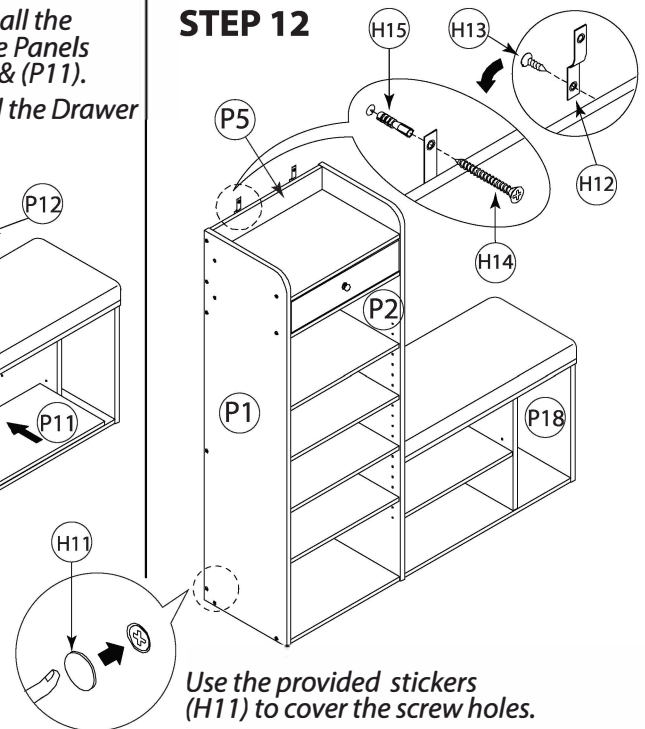

Use the provided stickers (H11) to cover the screw holes.

IMPORTANT!

ANCHOR THE UNIT TO THE WALL TO AVOID TIPPING.
PLACE THE HEAVIEST ITEMS IN THE LOWEST SHELVES.
NEVER ALLOW CHILDREN TO STAND OR CLIMB ON THE UNIT.

THE USE OF TIP-OVER RESTRAINTS MAY ONLY REDUCE, BUT NOT ELIMINATE, THE RISK OF TIP-OVER