

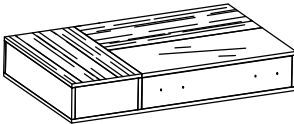
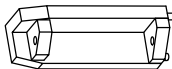

# ASSEMBLY INSTRUCTIONS

## LIFT COFFEE TABLE

Thank you for purchasing the quality product. Be sure to check all packing material carefully for small parts which may have come loose inside the carton during shipment. Separate, identify and count all parts and metal hardware. Compare with all parts list to be sure all parts are present. If any part(s) are missing or damaged, please contact your local furniture dealer. For efficient and speedy service, please indicate the model number and code letter of part(s) needed.

\*\*\* Do not fully tighten screws until fully assembled \*\*

COMPONENT PARTS		
DESCRIPTION	PART NAME	Q'TY (PCS)
①	TOP 	1
②	LEG 	4
③	SHELF 	1

## HARDWARE REQUIRED

(A)		BOLT	Ø1/4" x 1-1/2"	12PCS
(B)		SPRING WASHER	Ø1/4"	12PCS
(C)		FLAT WASHER	Ø1/4" x 16mm	12PCS
(D)		ALLEN KEY	Ø1/4"	1PC
(E)		CASTER		2PCS
(F)		CASTER W/BRAKE		2PCS
(G)		WRENCH		1PC
(H)		FLAT WASHER	Ø5/16"	4PCS

### Attention

\*\*\* Some number parts listed on the Instruction sheet may not be in parts bag as they may already be assembled. Carefully check parts and packing materials prior to ordering replacements.

# How to assemble:

## STEP 1

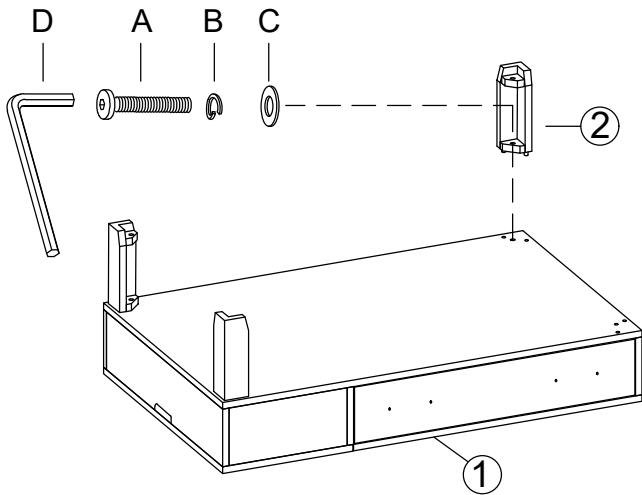

## STEP 2

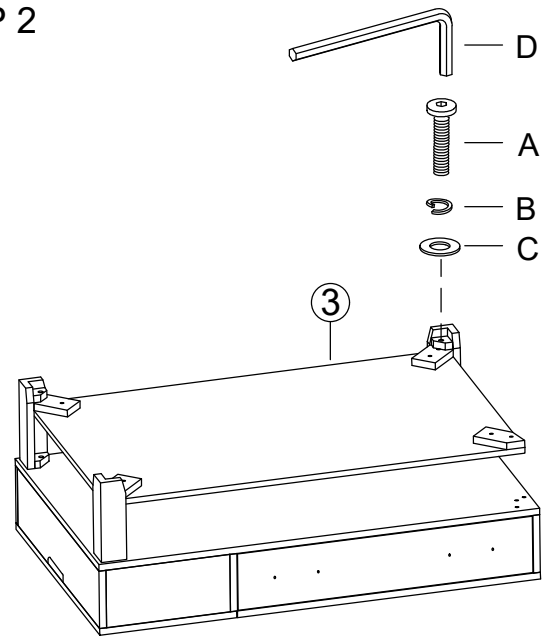

## STEP 3

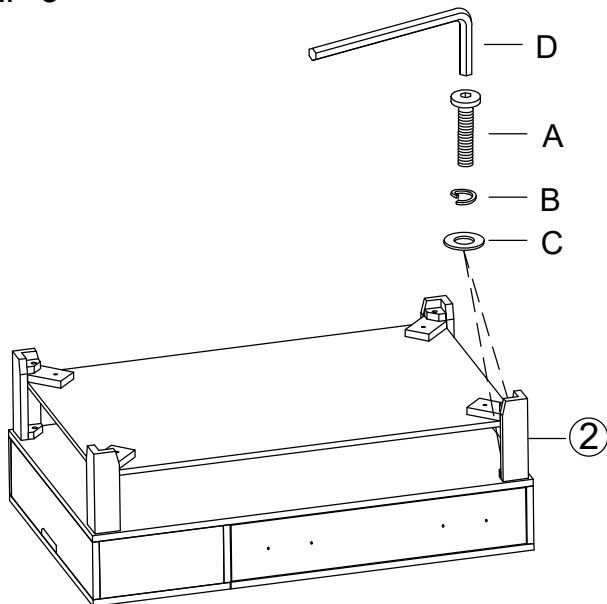

## STEP 4

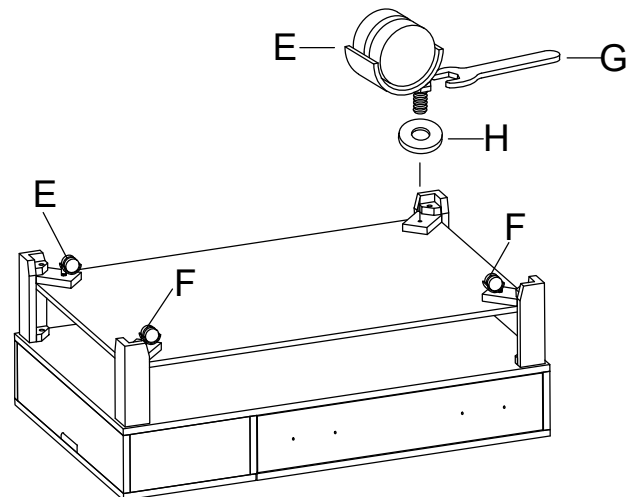

## STEP 5

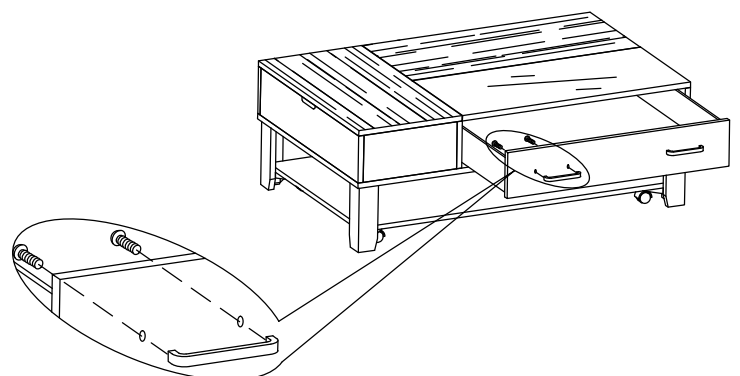
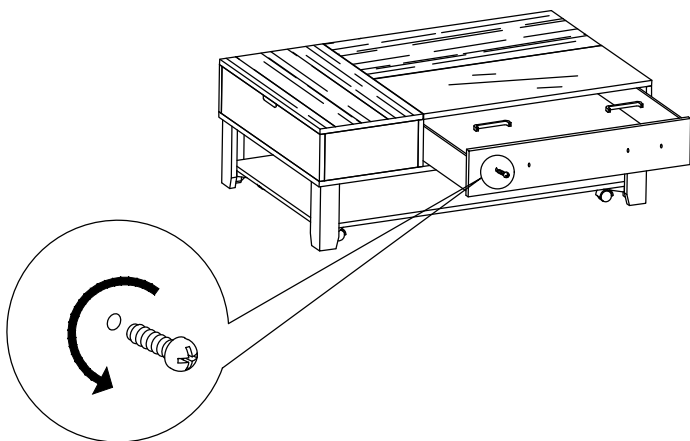



# ASSEMBLY INSTRUCTIONS

## USB END TABLE

Thank you for purchasing the quality product. Be sure to check all packing material carefully for small parts which may have come loose inside the carton during shipment. Separate, identify and count all parts and metal hardware. Compare with all parts list to be sure all parts are present. If any part(s) are missing or damaged, please contact your local furniture dealer. For efficient and speedy service, please indicate the model number and code letter of part(s) needed.

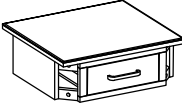
\*\*\* Do not fully tighten screws until fully assembled \*\*

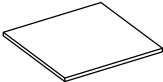
COMPONENT PARTS		
DESCRIPTION	PART NAME	Q'TY (PCS)
①	TOP 	1
②	LEG 	4
③	SHELF 	1

## HARDWARE REQUIRED

Ⓐ		BOLT	Ø1/4" x 2"	8PCS
Ⓑ		SPRING WASHER	Ø1/4"	8PCS
Ⓒ		FLAT WASHER	Ø1/4" x 16mm	8PCS
Ⓓ		ALLEN KEY	Ø1/4"	1PC
Ⓔ		SCREW		8PCS

### Attention

\*\*\* Some number parts listed on the Instruction sheet may not be in parts bag as they may already be assembled. Carefully check parts and packing materials prior to ordering replacements.

# How to assemble:

## STEP 1

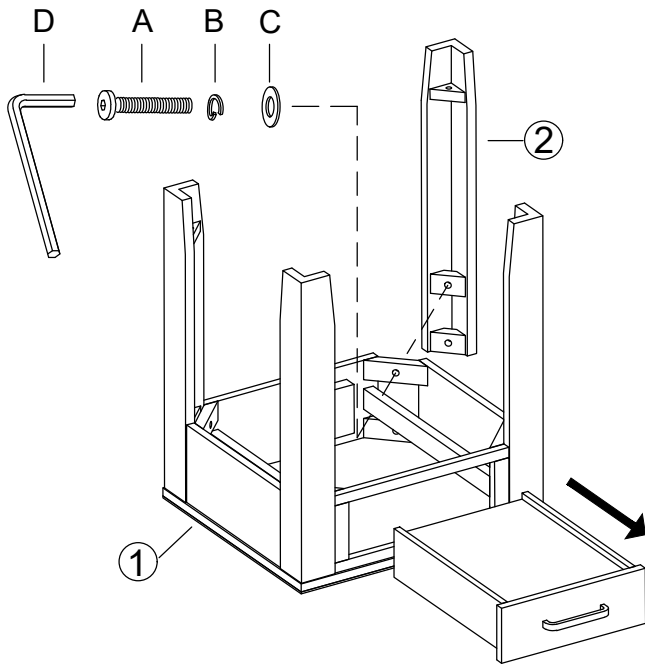

## STEP 2

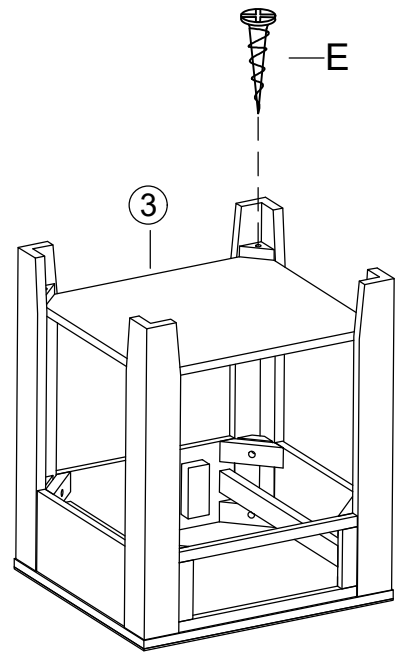

## STEP 3

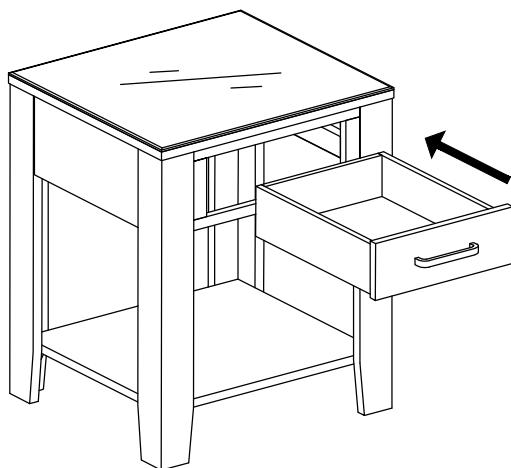

## FINISHED

