

**ZUC017**

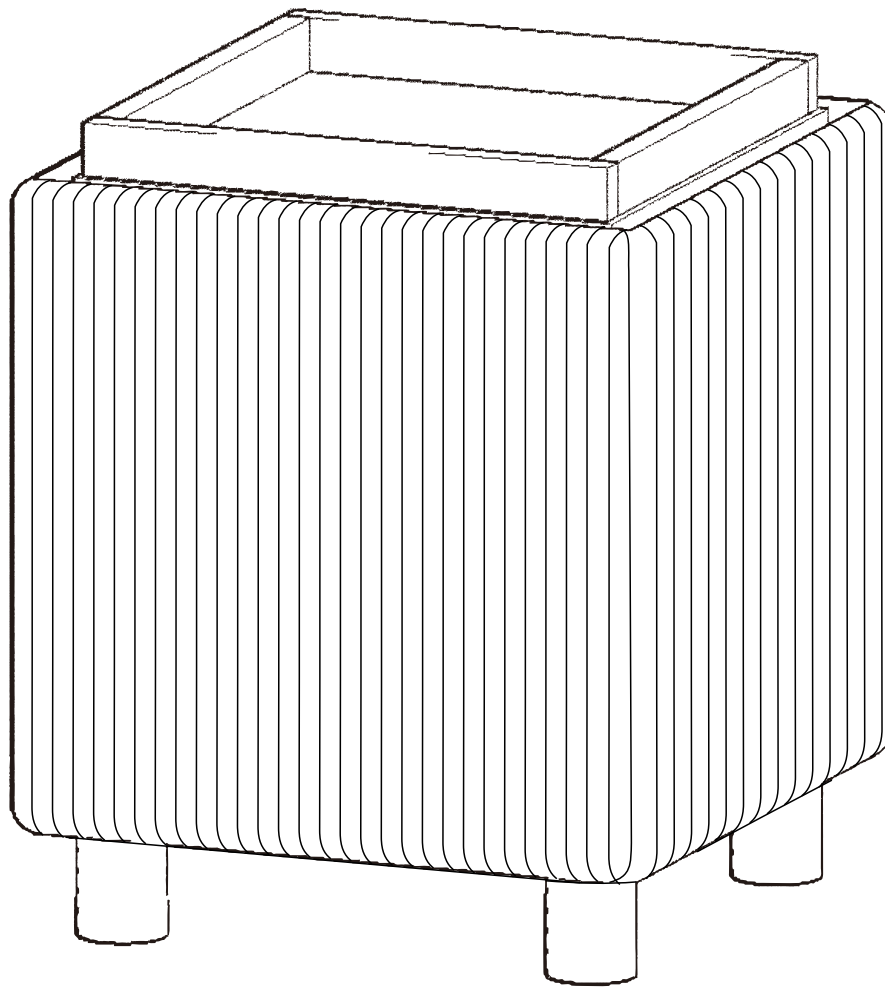

**INSTRUCTION MANUAL**



## ASSEMBLY INSTRUCTIONS

Carefully unpack all the components and verify that all the necessary parts are included as listed in the packaging.



Identify each component and refer to the provided assembly diagram or step-by-step instructions.

Assemble the furniture in the order specified to ensure proper alignment and fit.

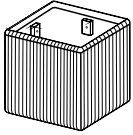
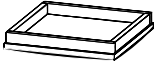

Use the provided tools or recommended tools for assembly. Do not use excessive force when tightening screws or bolts.

If any difficulties arise during assembly, consult the troubleshooting section or contact our customer support.

### Parts List



NO.	PICTURE	QTY
A	 Box	1
B	 Tray cover	1
C	 Plastic feet	4

### Hardware parts List

NO.	PICTURE	QTY
D	 Anti slip gasket	4
E	 White plastic foot nails	4

# :≡ Assembly Method : Option 1

## STEP 1

	Box
<b>A</b>	<b>X1</b>
	Plastic feet
<b>C</b>	<b>X4</b>
	Anti slip gasket
<b>D</b>	<b>X4</b>

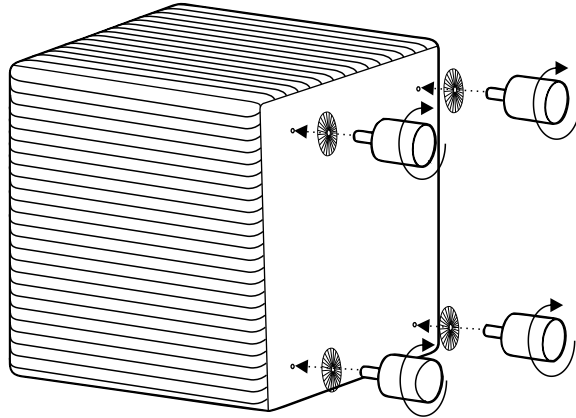

## STEP 2

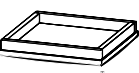
	Tray cover
<b>B</b>	<b>X1</b>

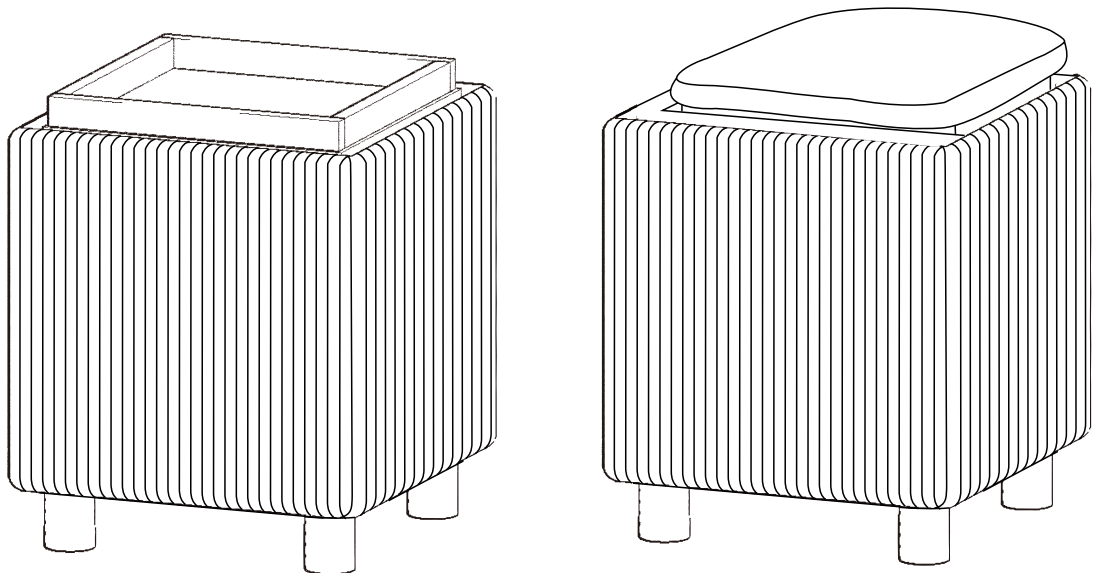

# ☰ Assembly Method : Option 2

## STEP 1

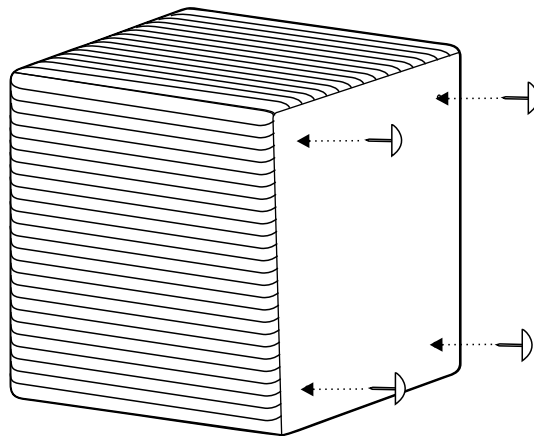
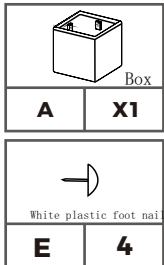

## STEP 2

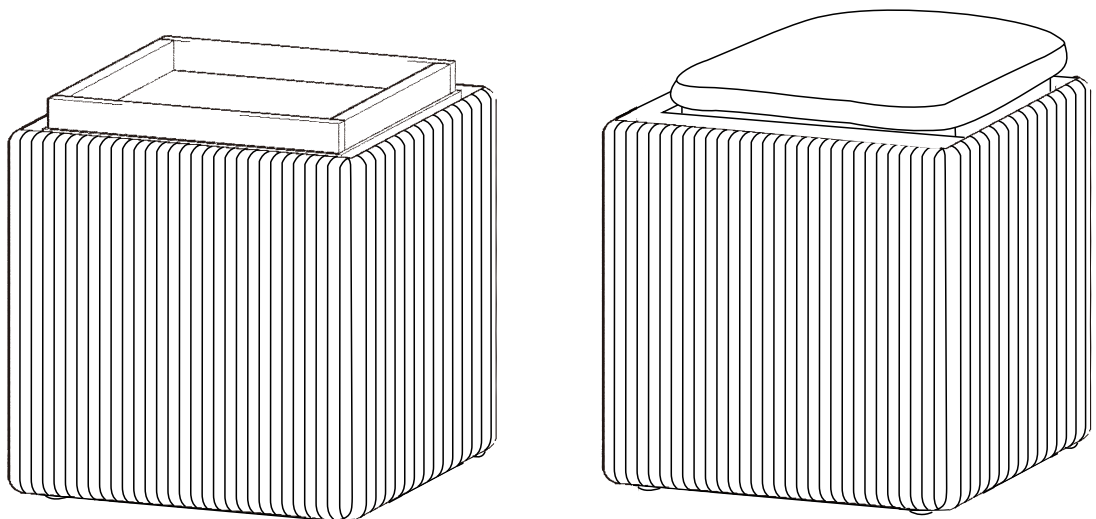
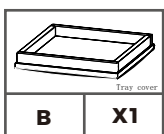



## MAINTENANCE AND CARE

Clean regularly using a soft brush or vacuum with a brush attachment. Avoid harsh chemicals or abrasive cleaners.

Wash with a hose or pressure washer on a low-pressure setting for heavy soiling. Rinse thoroughly afterward.

Ensure proper drying after cleaning or exposure to rain to prevent mold or mildew growth.

Protect from extreme weather by moving furniture to a covered area or using furniture covers or tarps.

Avoid dragging or placing heavy objects on the furniture to prevent damage.

Apply UV protection spray or furniture wax to prevent fading and damage from the sun.

Regularly inspect for wear, loose strands, or damage and address issues promptly.



## WARRANTY INFORMATION

**Warranty Coverage:** Our warranty provides protection against manufacturing defects in materials and workmanship for a specified period from the date of purchase, as outlined in the accompanying warranty documentation.

**Exclusions:** The warranty does not cover damages resulting from misuse, negligence, accidents, normal wear and tear, unauthorized repairs or modifications, improper assembly, or failure to adhere to the care and maintenance guidelines provided.

### Warranty Claim Process

Turn on Amazon, please follow these steps:

- 1 Log into your Amazon account and go to the "Your Orders" section.
- 2 Locate the order containing the item you wish to return.
- 3 Contact our customer service for assistance in obtaining a prepaid return label.
- 4 Once you receive the return label, securely affix it to the package.
- 5 You can then choose to drop off the package at a designated carrier location or arrange for a pickup.
- 6 After we receive and inspect the returned product, we will initiate the refund process.
- 7 The refund will be credited back to the original payment method used during the purchase.
- 8 Typically, refunds are processed within 3-5 business days. To initiate a return



## **Contact Information**

---

**If you have any questions, concerns, or need assistance,  
please reach out to our customer support team using the contact information  
provided below:**

**Customer Support Email**

**[support@sunvivi.com](mailto:support@sunvivi.com)**

---