

# ASSEMBLY INSTRUCTIONS

ASSEMBLY  
REQUIREMENTS

1-Person  
Assembly

Assembly Time 60 minutes  
(Approximate)

Thank you for purchasing our product !

Please refer and use this assembly instruction to assemble the product. Contact our customer service department in case there are any missing or damage parts or hardware. Replacement parts are normally shipped within 2 or 3 days.

We appreciate your business!



## ASSEMBLY PREPARATION

1. Remove all packaging materials, staples and packing straps from the carton .
2. Refer to Parts List and Hardware List, and ensure parts and hardware are correct before assembly. Contact customer service for missing parts.
3. Place all wooden parts on a clean, flat and soft surface (e.g. carpet or rug) to prevent scratch and damage to parts.

## SAFETY PRECAUTION

1. KEEP ALL HARDWARE PARTS OUT OF REACH OF CHILDREN.
2. DISPOSE PLASTIC PACKAGING MATERIAL IMMEDIATELY TO AVOID ANY RISK OF SUFFOCATION TO CHILDREN AND ANIMALS.

## TIPS FOR ASSEMBLY











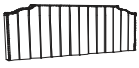

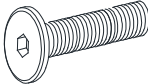



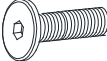

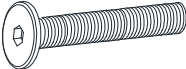
1. Allow ample room for assembly and assemble the product near where the product will be placed.
2. Assemble the product on a surface that does not scratch or damage the exterior gloss and finish of the furniture.
3. Identify all of the parts, hardware and quantities required for each step.
4. During assembly, do not over-tighten any fittings as this may cause damage.
5. DO NOT USE POWER TOOLS TO ASSEMBLE THIS PRODUCT.
6. Always place the product on a flat, level surface.
7. Do not sit or stand on the partially assembled product; only use the product for which it is intended.

## CARE AND MAINTENANCE

Use a slightly damp cloth to clean the product. Do not use bleach or abrasive cleaning material. Check all the fittings periodically and re-tighten as necessary. Do not use the product if any of the parts is damaged or broken. Never allow any kind of liquid to remain on your furniture. Absorption can cause wood to warp or delaminate. Do not place hot items (e.g. hot drinks) directly onto the wood surface. Do not drag and/or pull the furniture.

This product is for indoor and household use only - not for commercial use.

## ASSEMBLY INSTRUCTIONS

NO	PART LIST	QTY	NO	HARDWARE	QTY
1	 HEADBOARD CUSHION	1PC	A	 ALLEN KEY	1PC
2	 HEADBOARD LEGS	2PCS	B	 BOLT 5/16*50	6PCS
3	 SIDE RAILS (L/R)	4PCS	C	 BOLT 5/16*25	8PCS
4	 FOOTBOARDS CUSHION	2PCS	D	 BOLT 1/4*35	8PCS
5	 SLATS	8PCS	E	 BOLT 1/4*60	4PCS
6	 CENTER SUPPORT BAR	2PCS	F	 FLAT WASHER 5/16	14PCS
7	 FOOTBOARD LEGS	2PCS	G	 FLAT WASHER 1/4	12PCS
8	 CENTER SUPPORT LEGS (With adjustable feet)	4PCS	H	 SPRING WASHER 5/16	14PCS
9	 SIDE RAIL LEGS	2PCS	I	 SPRING WASHER 1/4	12PCS
			K	 SCREW F4x30	32PCS

## STEP 1

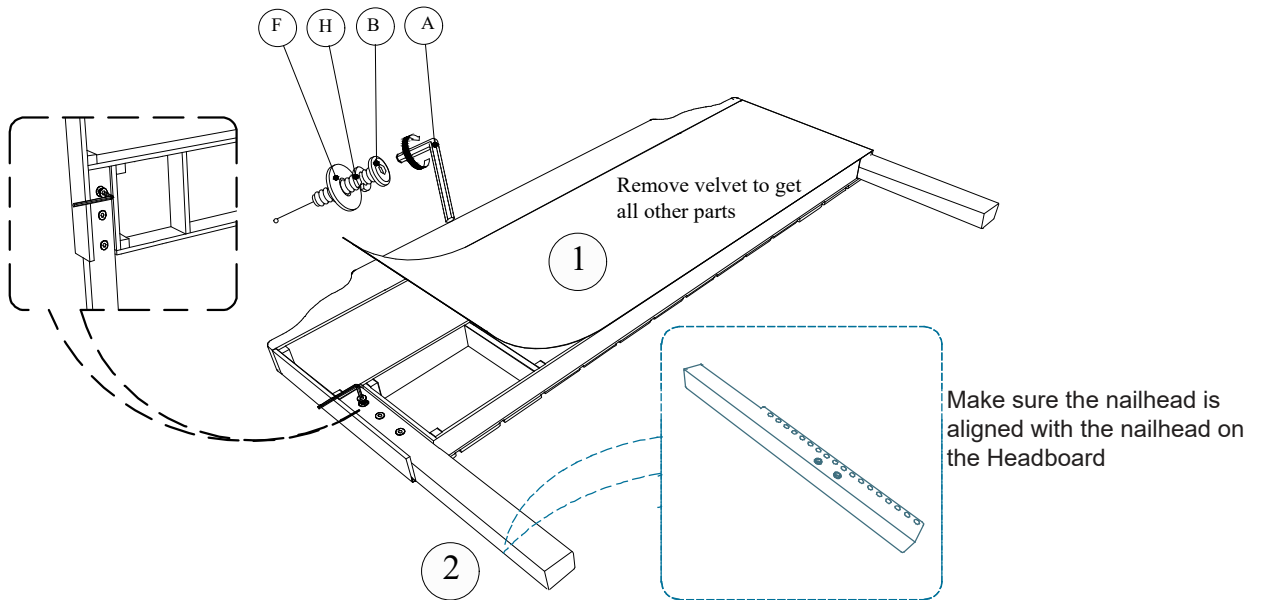

- A. With assistance, lay Headboard (1) flat with the front-side facing down on a material that does not scratch or damage the upholstery and peel back the back cover and remove the other parts stored within the headboard.
- B. Attach Headboard Leg (2) to (1) and fasten with Bolt (B) fitted with Spring Washer (H) and FlatWasher (F)

## STEP 2

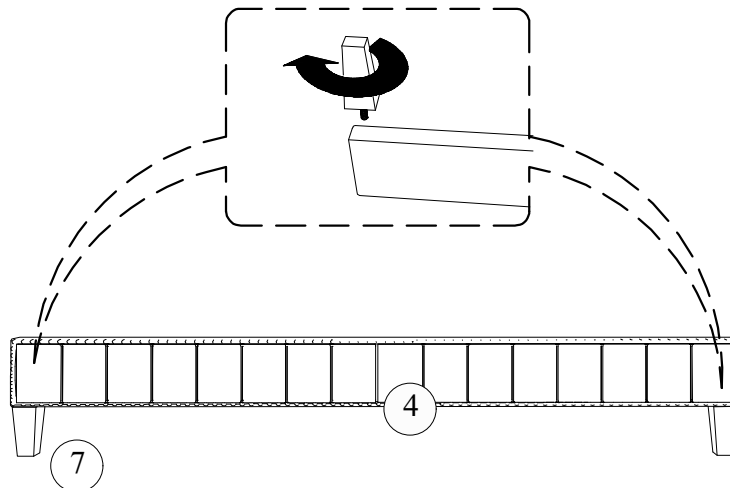

- A. Screw in Footboard Leg (7) to Footboard (4) as shown.

## STEP 3

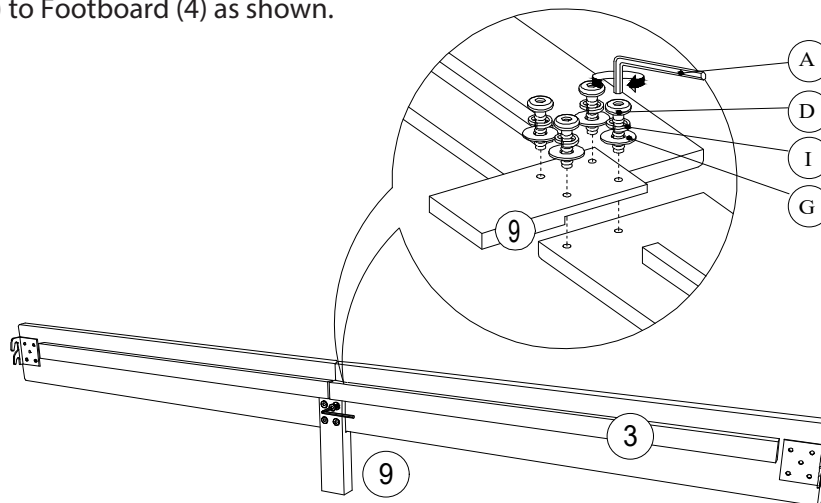

- A. Lay 2 pieces of Side Rail (3) flat with the exterior surface facing down on a material that does not scratch or damage the part.
- B. Use Side Rail Leg (9) to join the 2 pieces of side rail and fasten with Bolt (D) fitted with Washer (I) and Flat Washer (G) . Use Allen Key (A) to drive and tighten (D).

## STEP 4

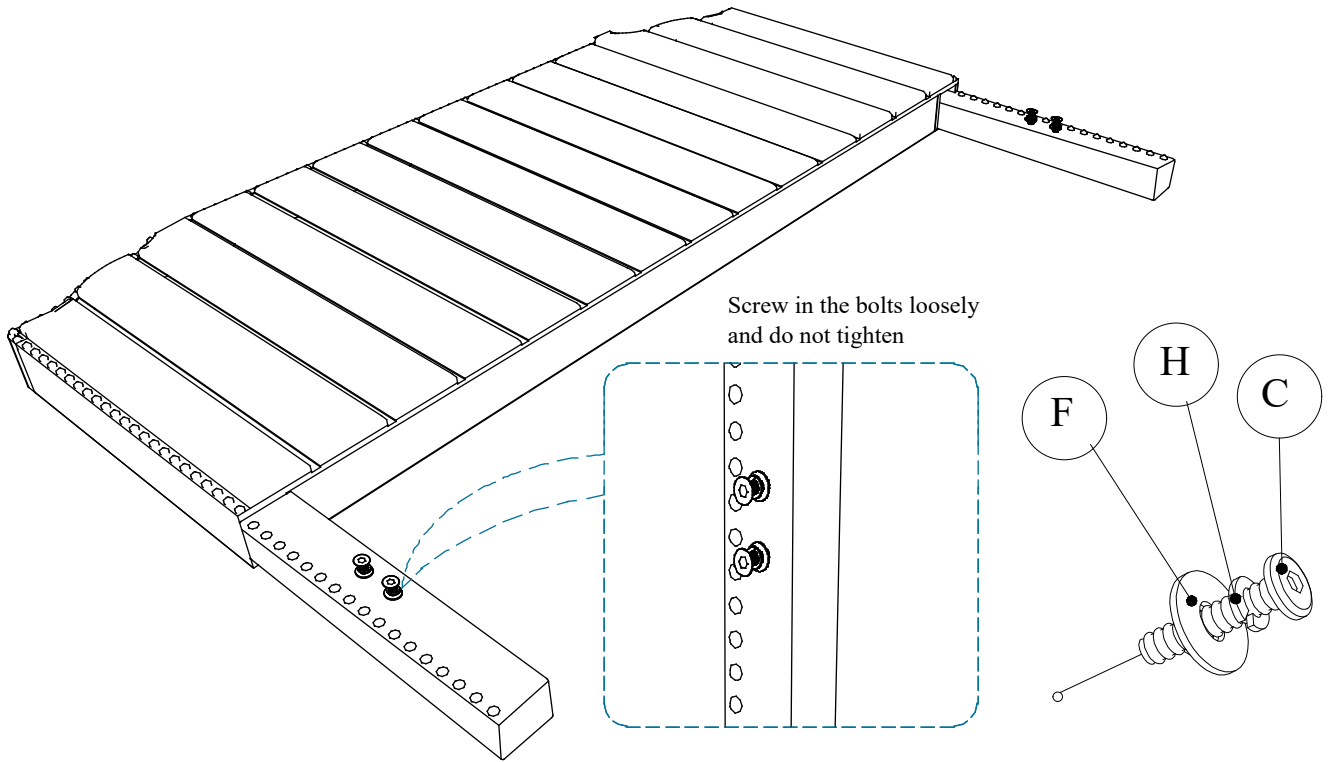

A. Install the Bolts (C) fitted with Spring Washer (H) and Flat Washer (F) into 4 driving nuts on 2 Headboard Leg (2).

## STEP 5

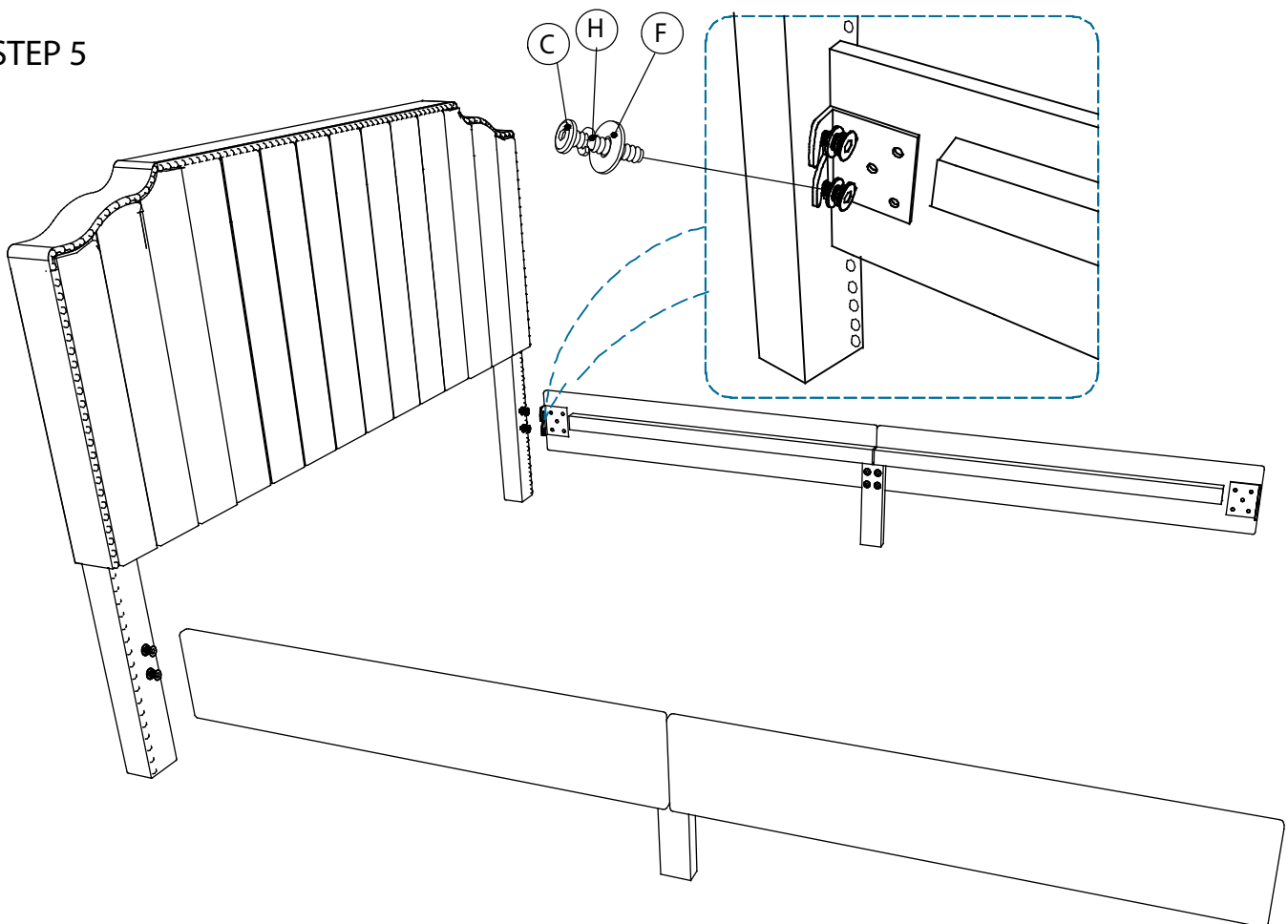

A. Put the metal Hooks of the Side Rails (3) so that the metal Hooks fit onto the Bolts (C) on Headboard Legs (2).

## STEP 6

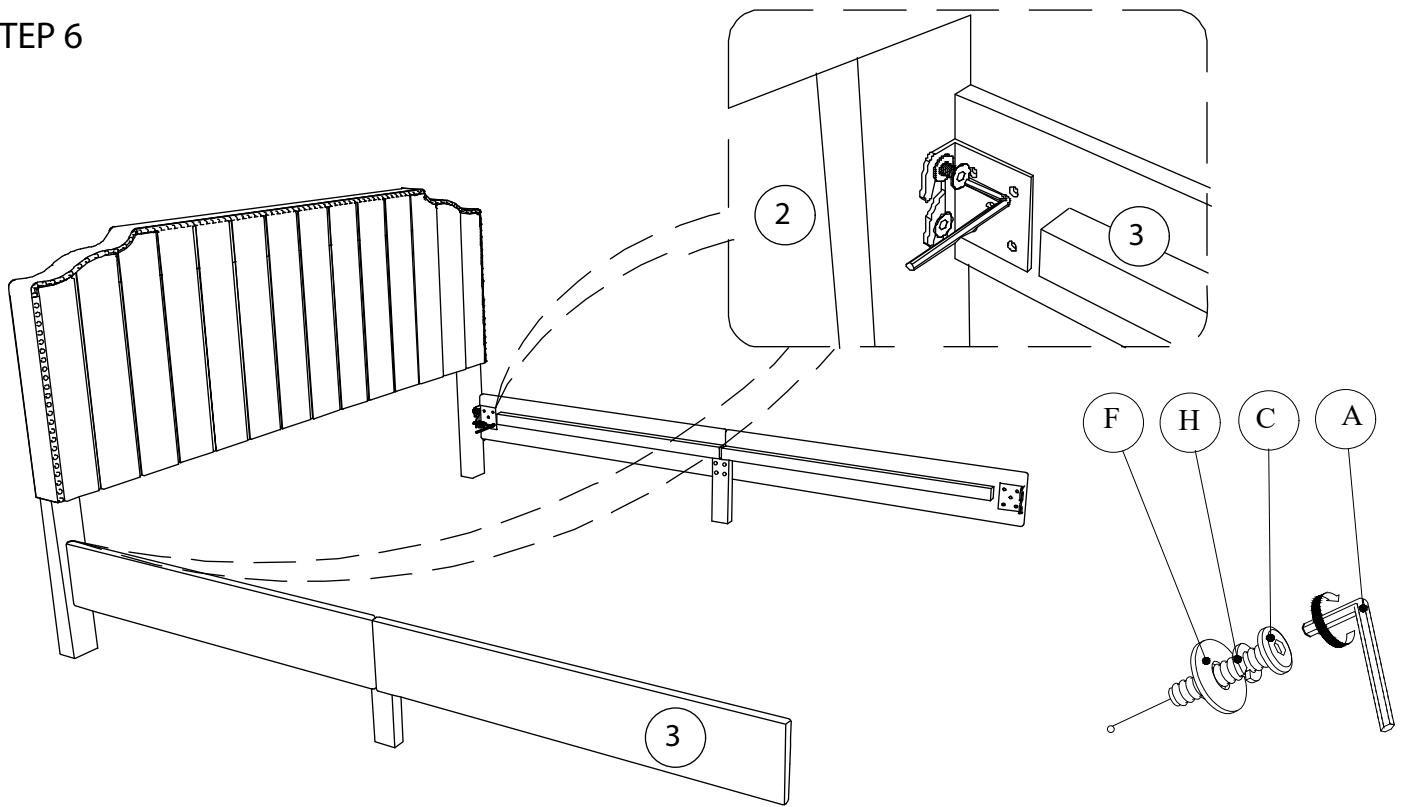

A. Tighten the bolts after hooks are placed on Headboard(1).

## STEP 7

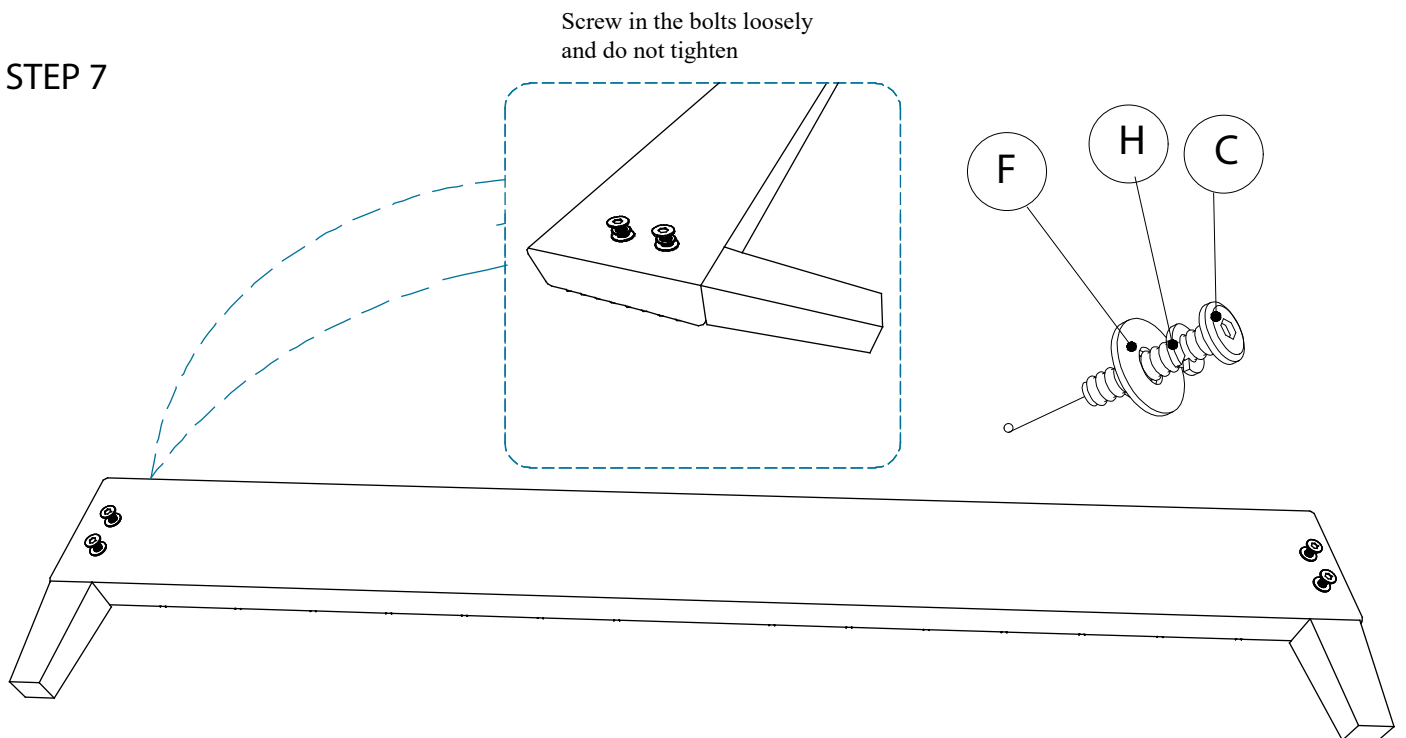

A. Install the Bolts (C) fitted Spring Washer (H) and Flat Washer (F) into 4 driving nuts on Footboard (4)

## STEP 8

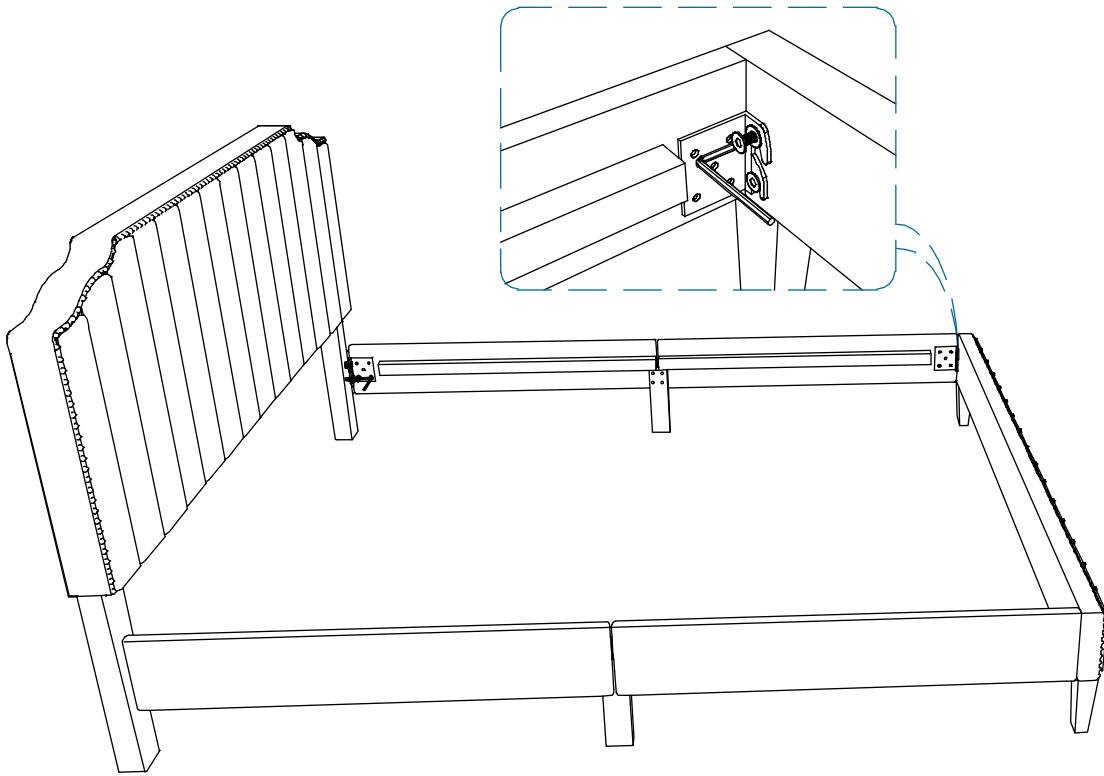

- A. With assistance, attach each side rail(3) from Step 3 to Footboard(4) by fitting the hook plate to the Bolts(C).
- B. Tighten the bolts(C) after the hooks are placed on the Footboard(4).

## STEP 9

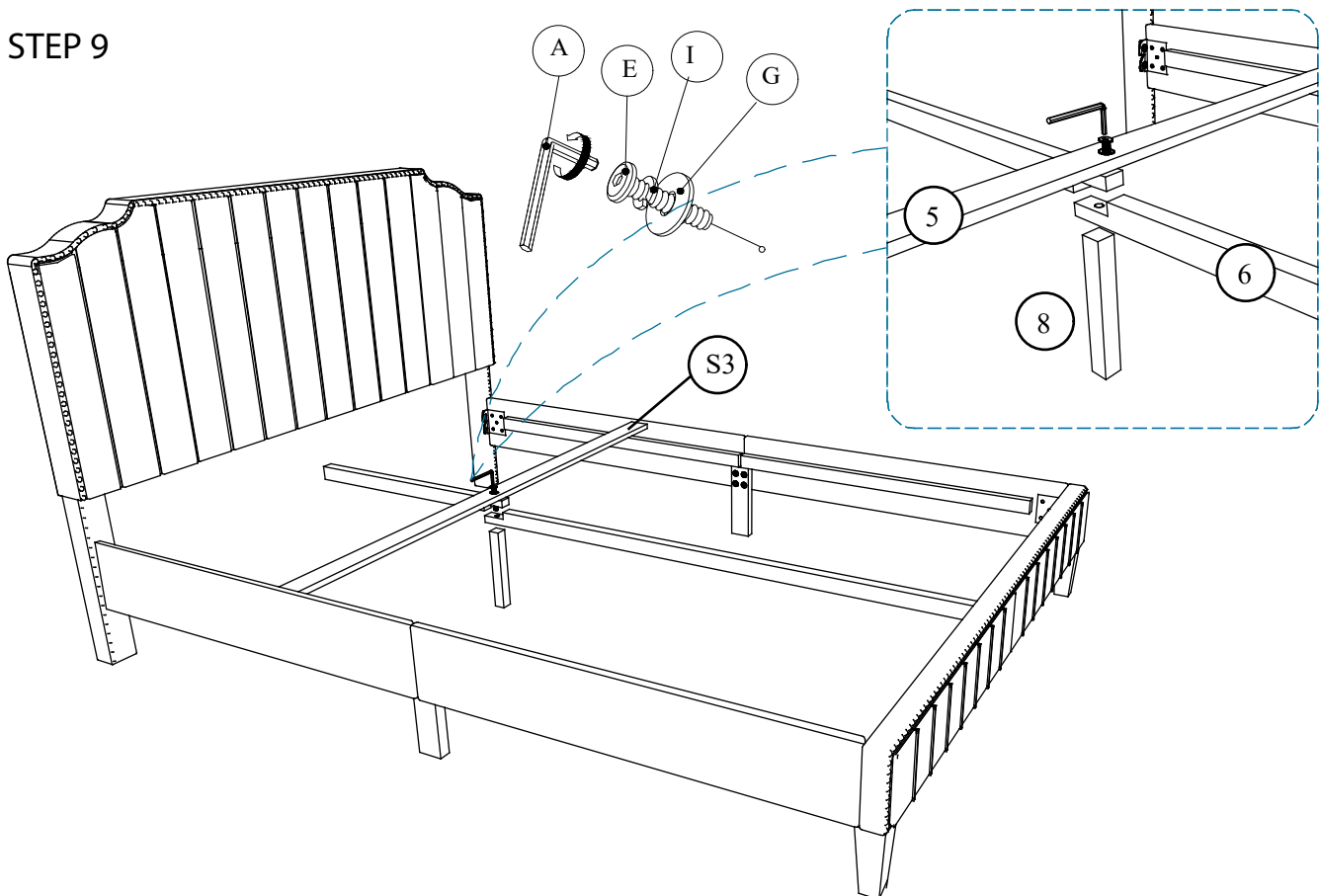

- A. Put the Slat (S3) on the connect joint of 2 Center Support Bars (6) with the Center Support Legs (8). Then use the Allen Key (A) to tighten the Bolt (E) accompanied with the Spring Washer (I) and Flat Washer (G).

## STEP 10

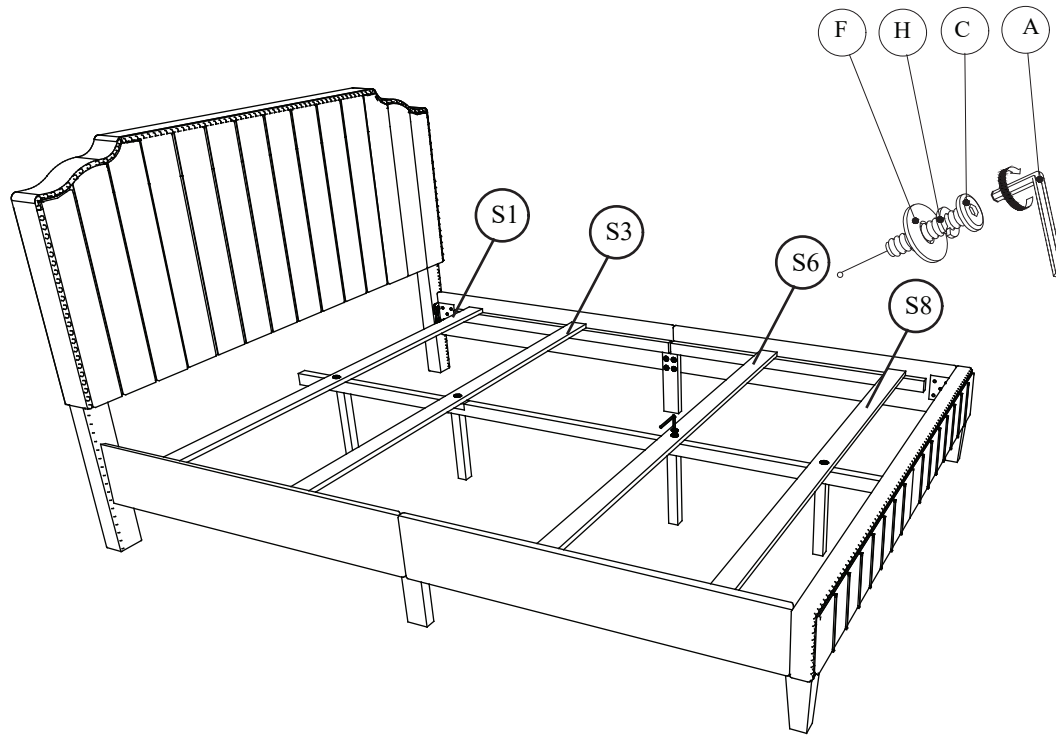

- A. Put Slat ( S1 ) , (S6), (S8) respectively on the Center Support Bar (6) so that the Slats (5) are right at the drilled holes on the Center Support Bar accompanied with Center Support Legs (8).  
B. Use the Allen Key (A) to tighten the Bolt (E) accompanied with the Spring Washer (I) and Flat Washer (G) for (S1), (S6) & (S8).

## STEP 11

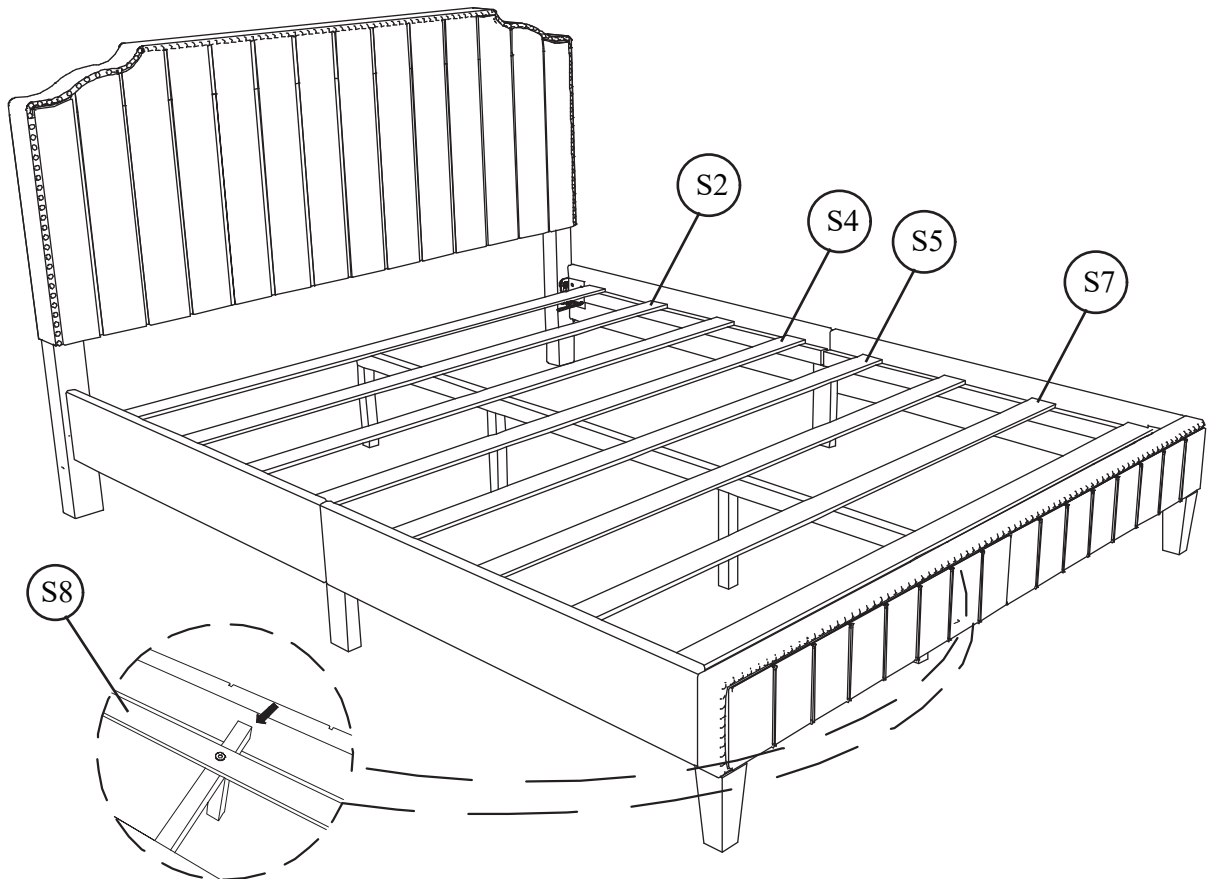

- A. Put (S2) , (S4) , (S5), (S7) into the empty space left on the Center Support Bar (6) so that their distance is equal.  
B. The center Support Bar (6) has to be up against the Footboard Cushion (4).

## STEP 12

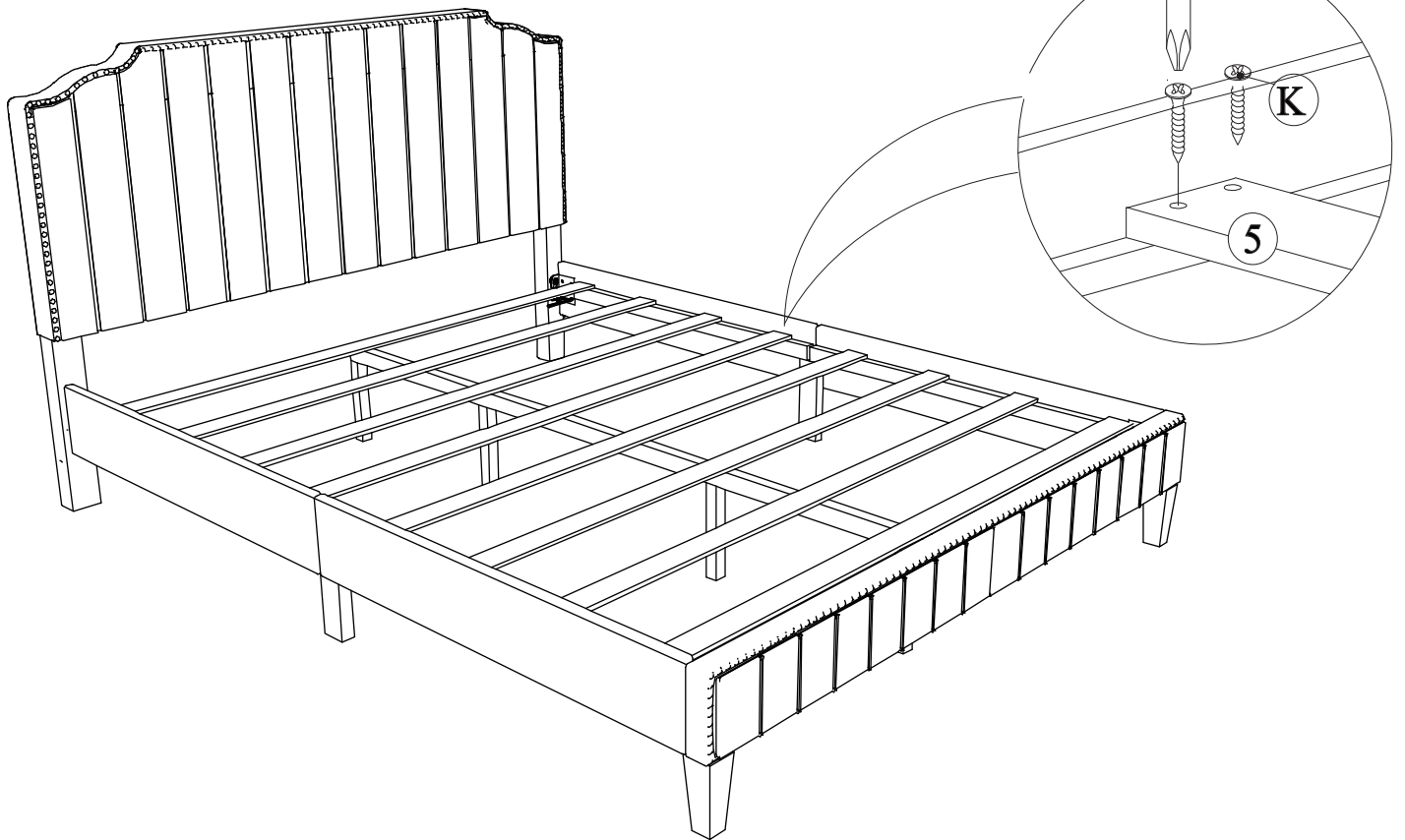

A. Use the Screw driver to tighten 4 Screw (K) onto both end of all Slats (5).

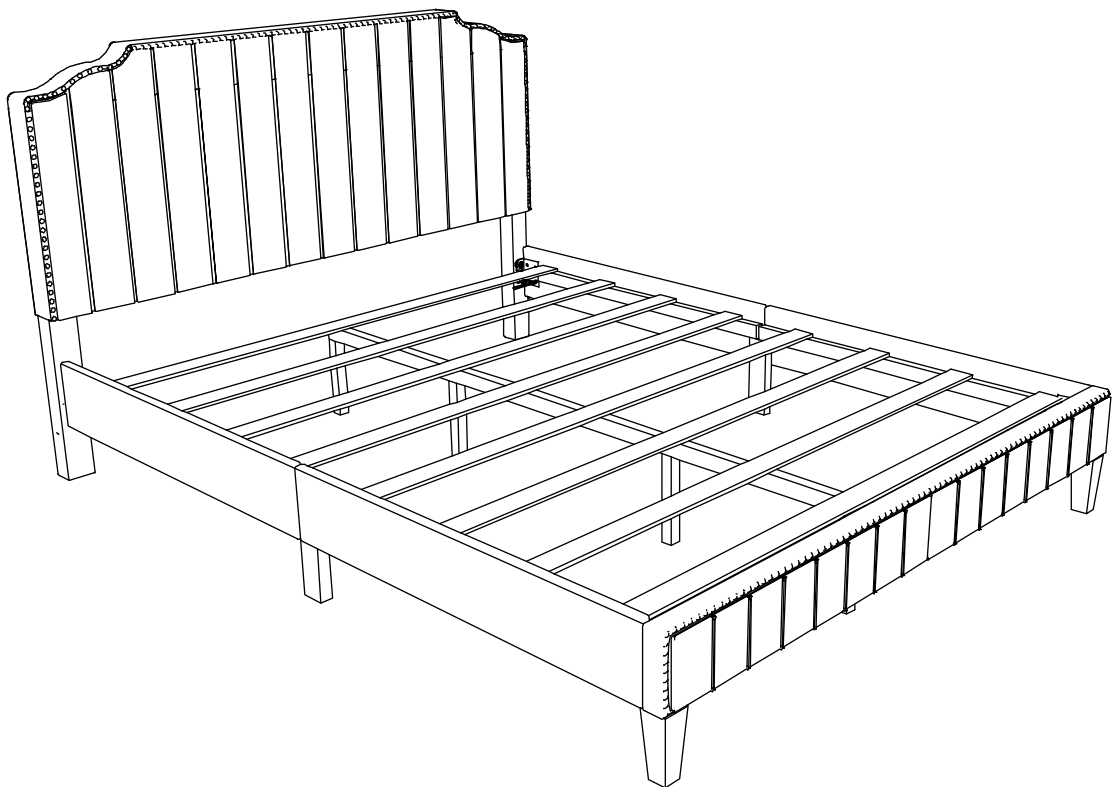

The assembly of the bed is complete.