

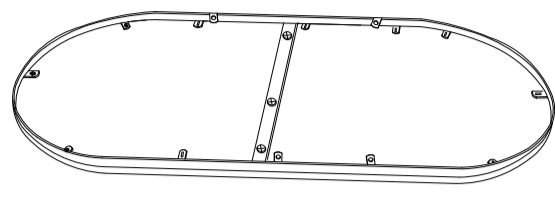
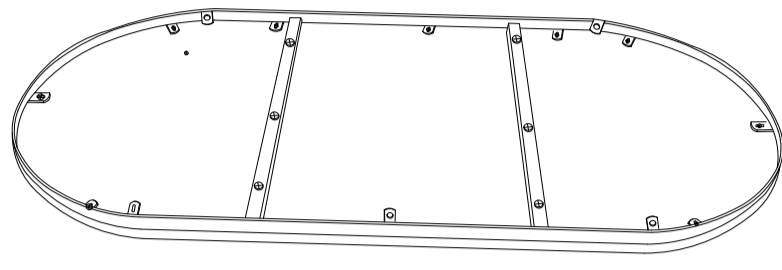

ASSEMBLY INSTRUCTIONS

CVFNR4216

PARTS

S.NO.	DESCRIPTION	QTY.
P	 TOP	1 Pc
Q	 BOTTOM	1 Pc
R	 LEGS(BIG) R1,R2,R3,R4	4 Pcs
S	 LEGS(SMALL) S1,S2	2 Pcs

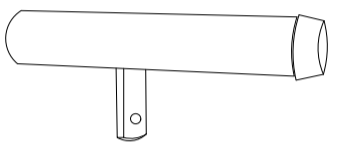
HARDWARE

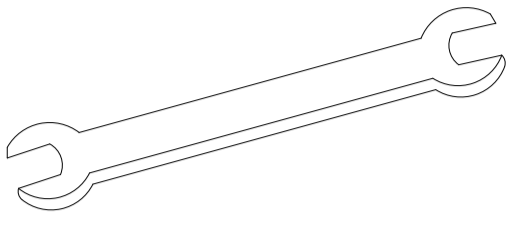
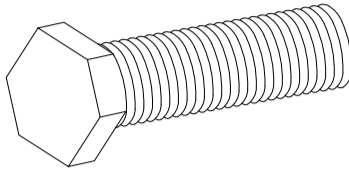
S.NO.	DESCRIPTION	QTY.
A	 Spanner Wrench	1Pc
B	 Bolt	10 Pcs

STEP-1

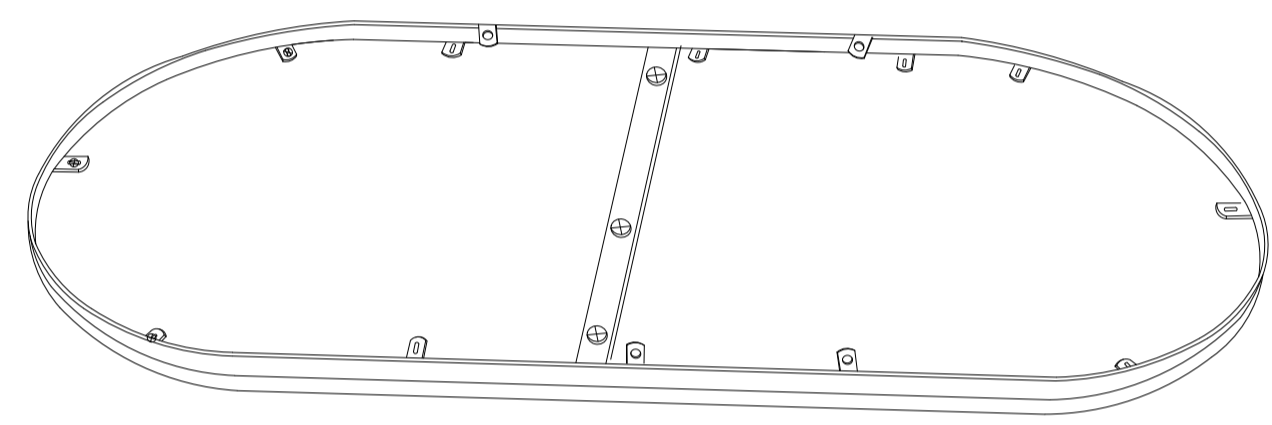

P

STEP-2

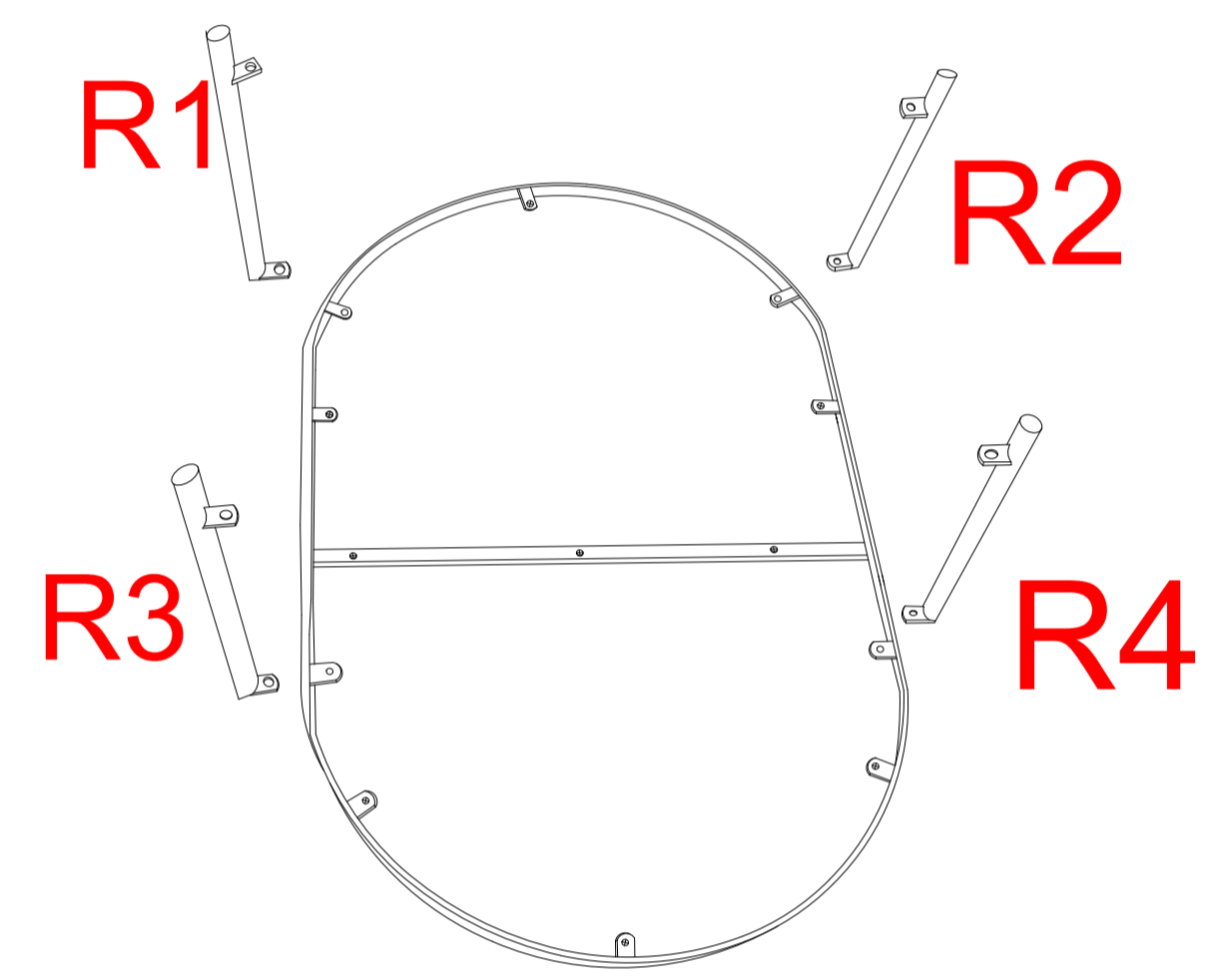

P

STEP-3

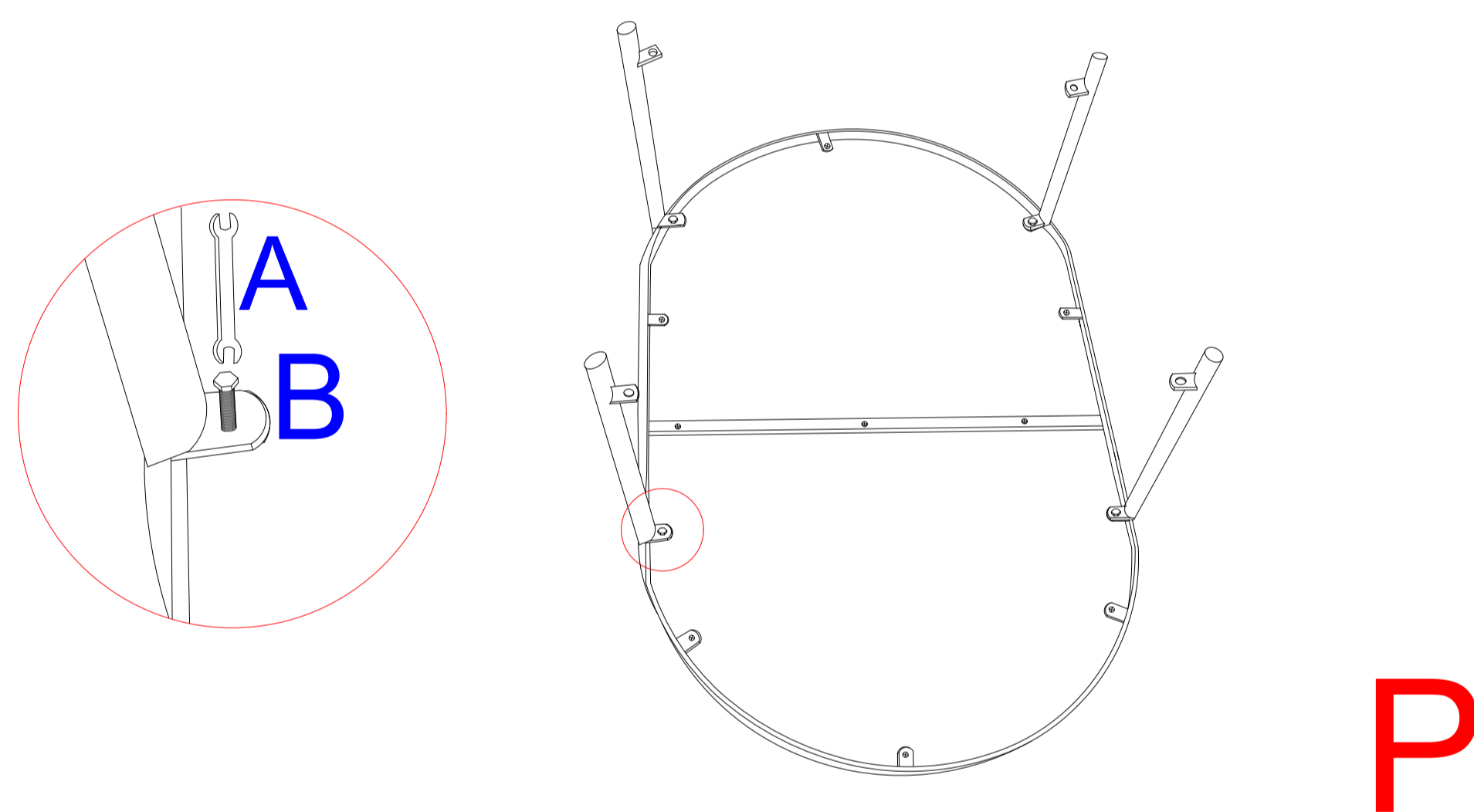

P

STEP-4

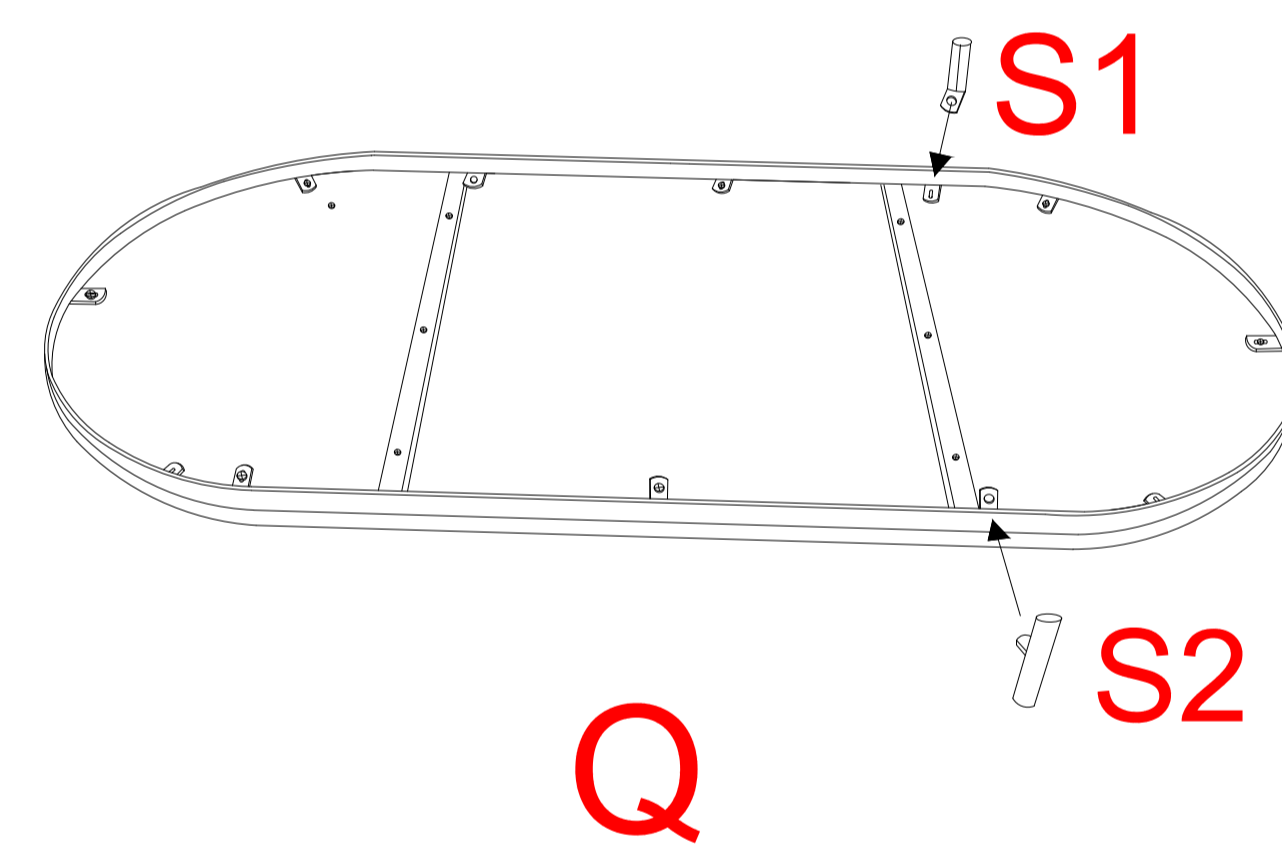

Q

STEP-5

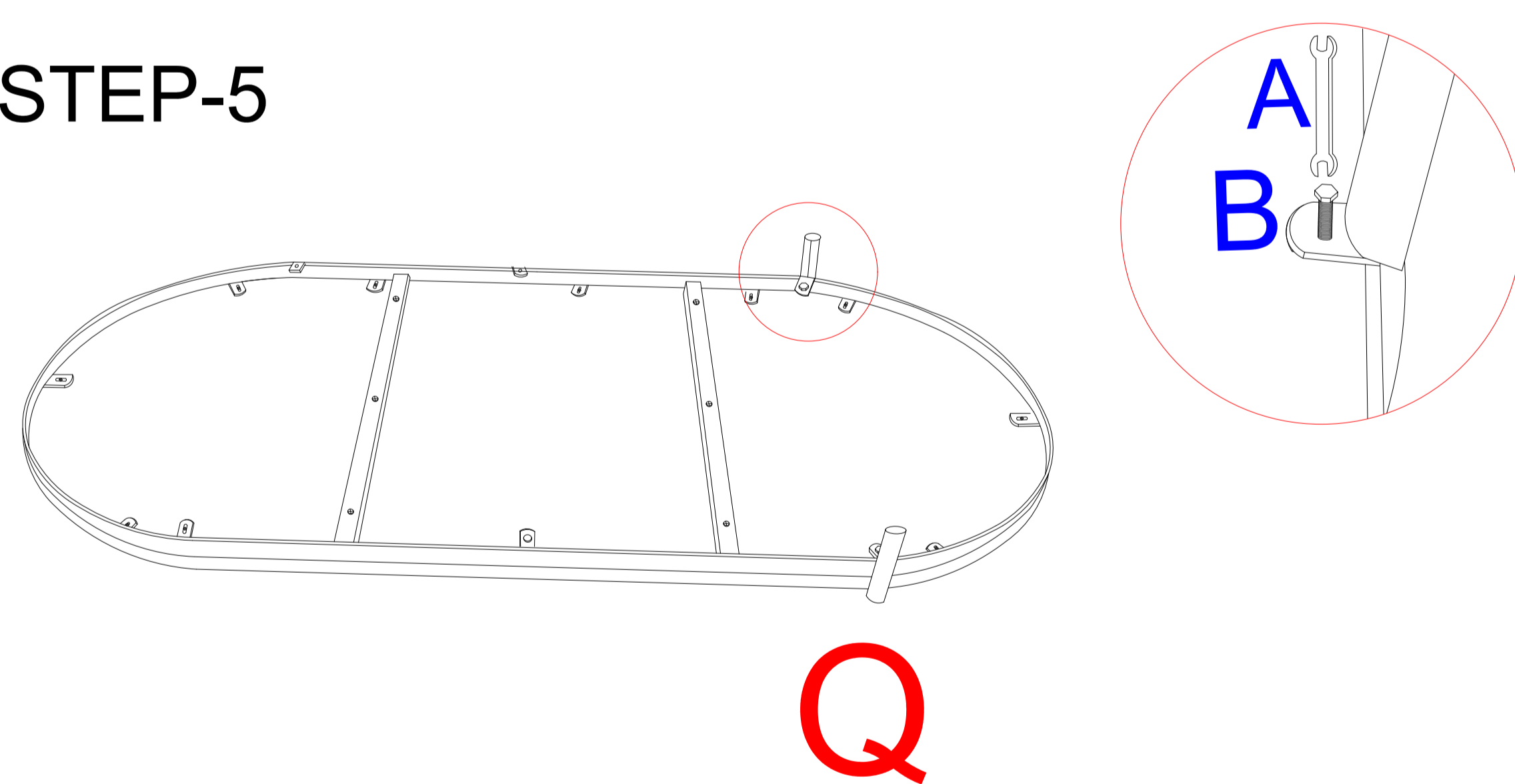

Q

STEP-6

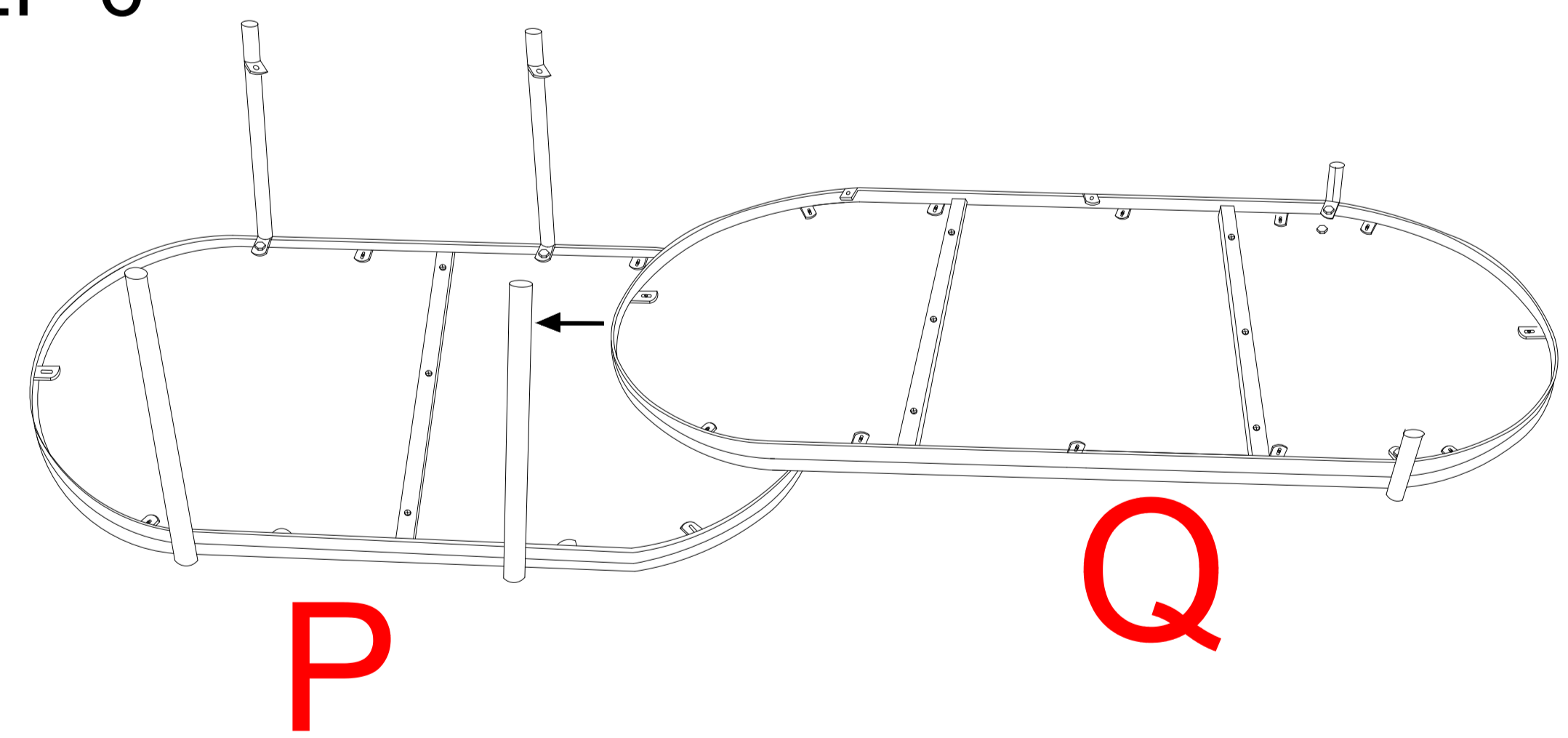

P

Q

STEP-7

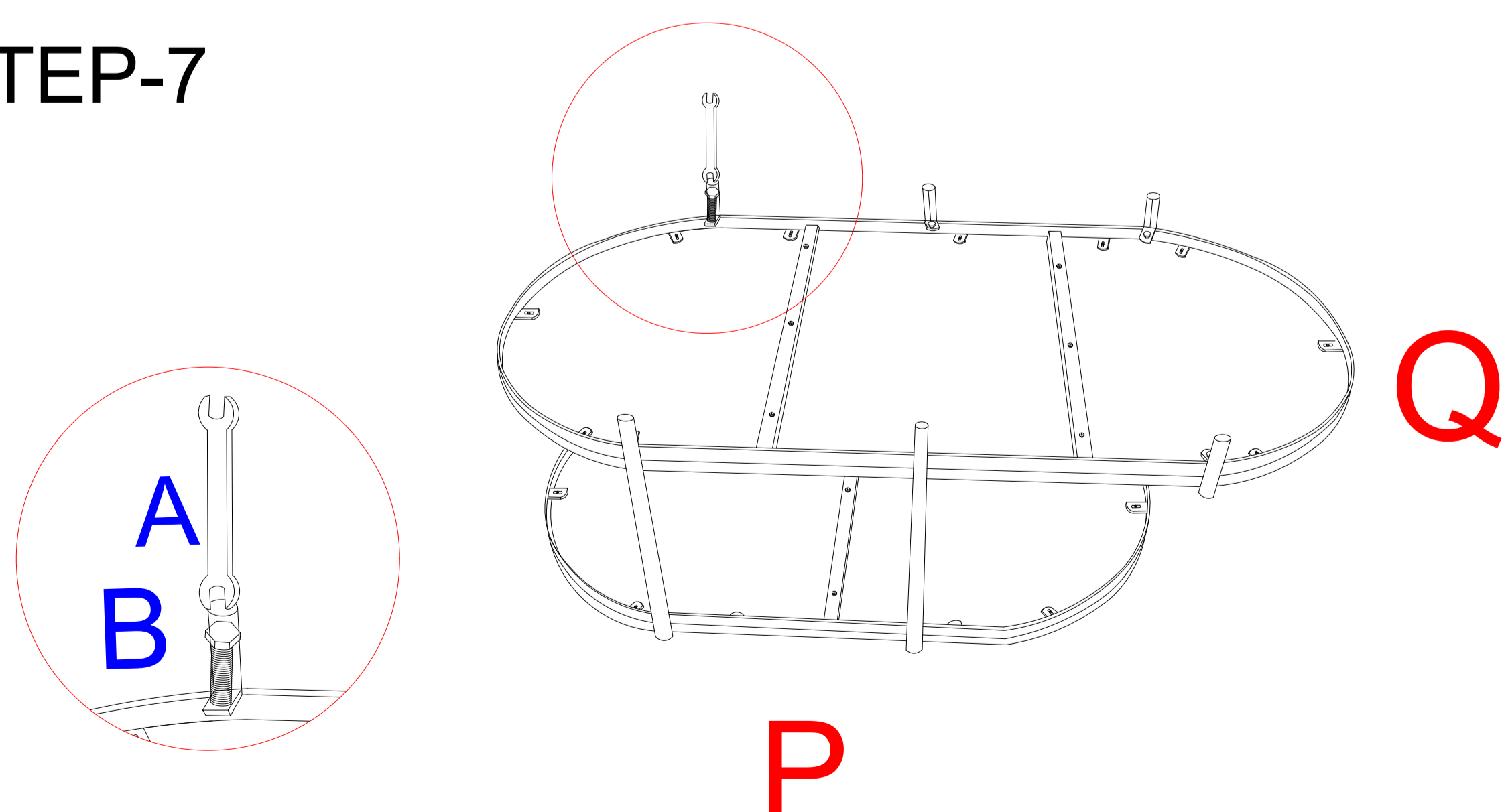

Q

P

STEP-7

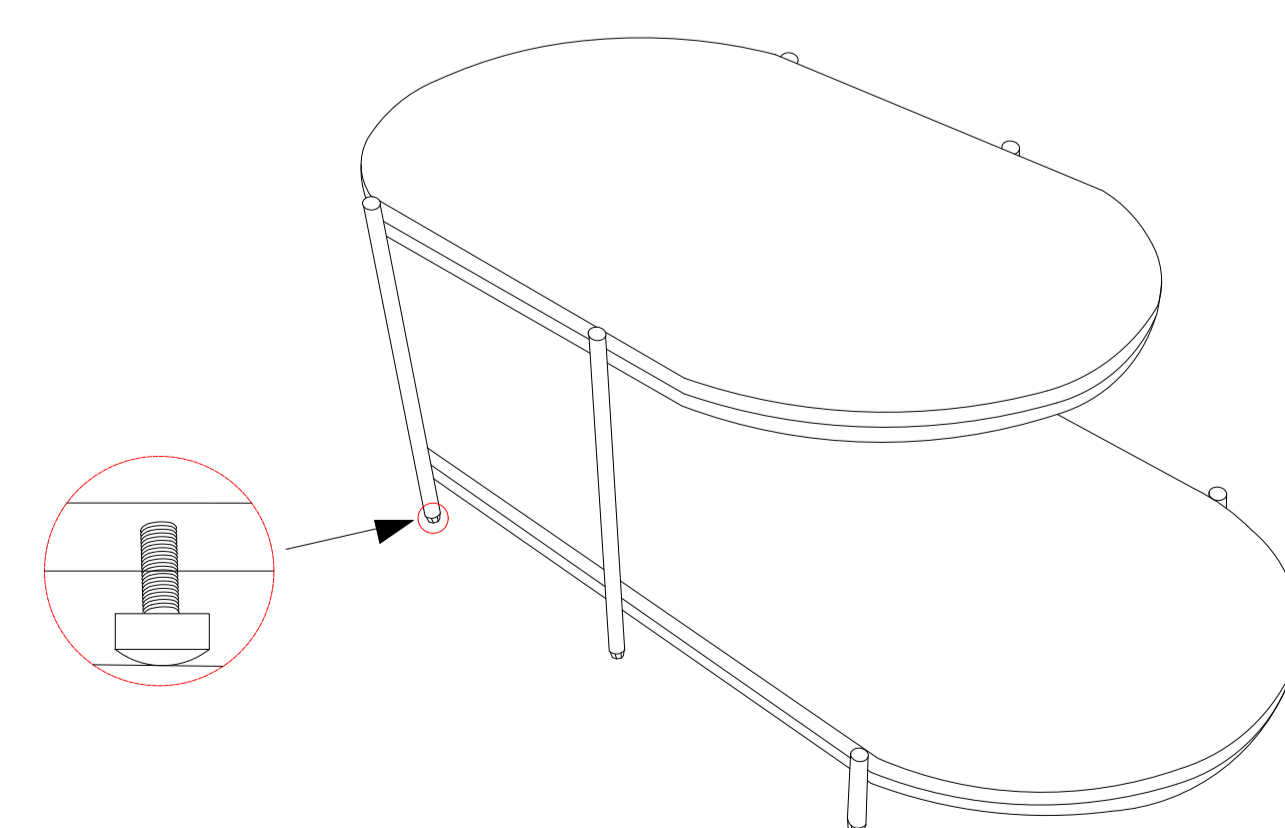

Note: Levellers are provided at bottom to balance the product on uneven surface.