

INSTRUCTIONS

IMPORTANT - PLEASE RETAIN FOR FUTURE REFERENCE

FOOT TYPE 1:

REMOVE TRANSPORT GLIDE - UNSCREW ANTI-CLOCKWISE

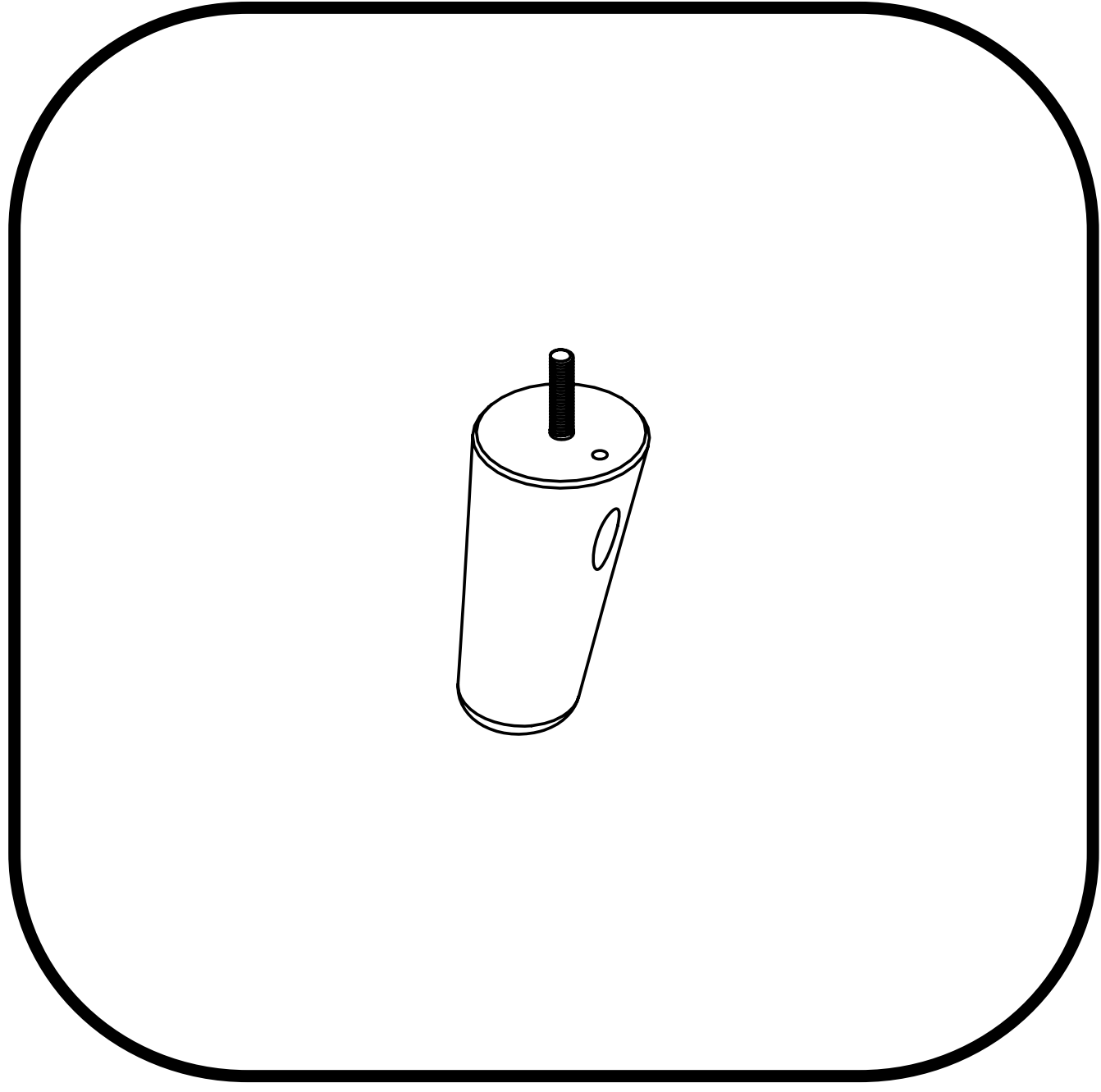

- UNPACKAGE FOOT AND CHECK FOR DAMAGES

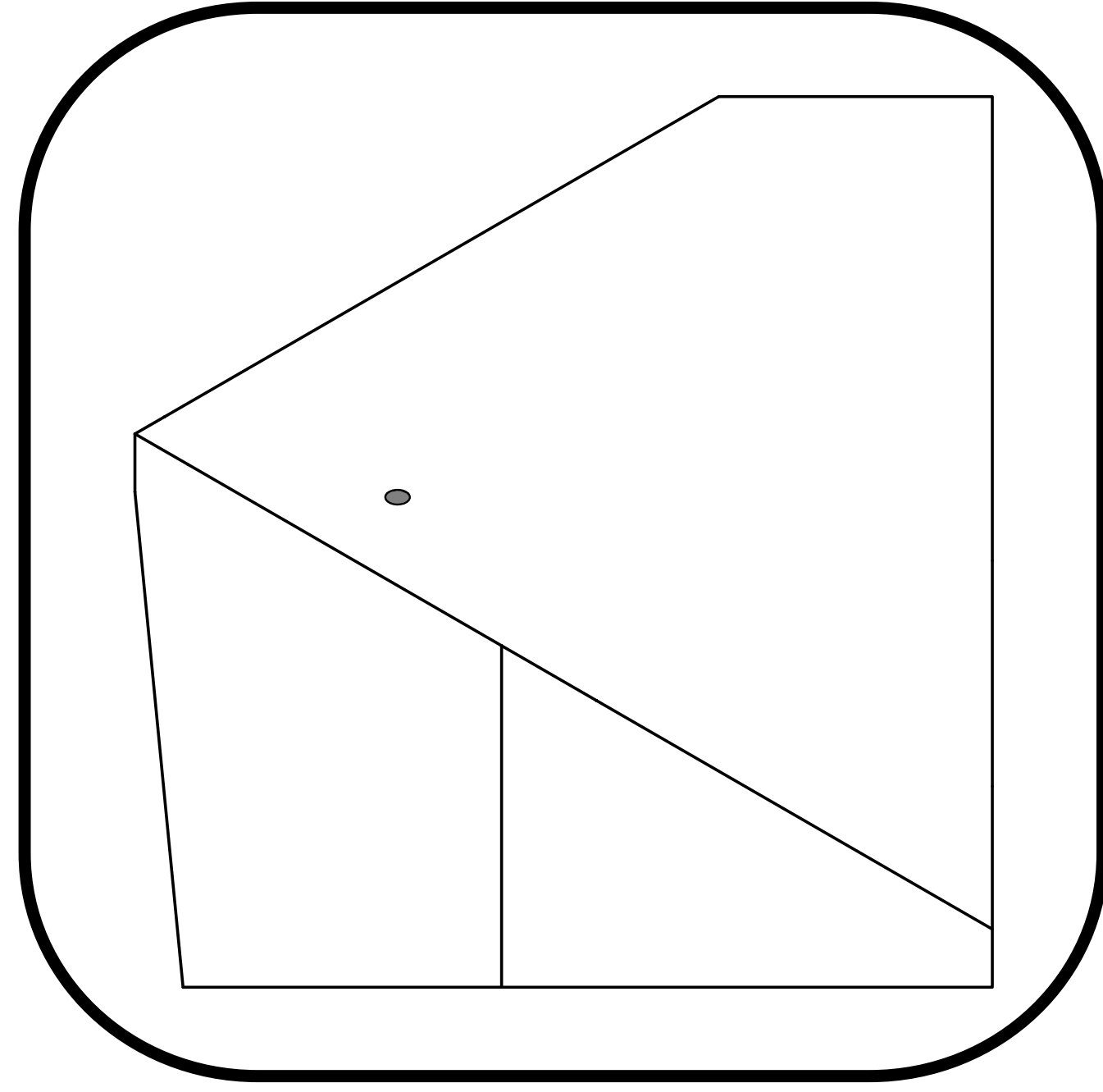

- TURN SOFA OVER
- LOCATE PRE-DRILLED HOLE FROM TRANSPORT GLIDE, ON BOTTOM OF SOFA

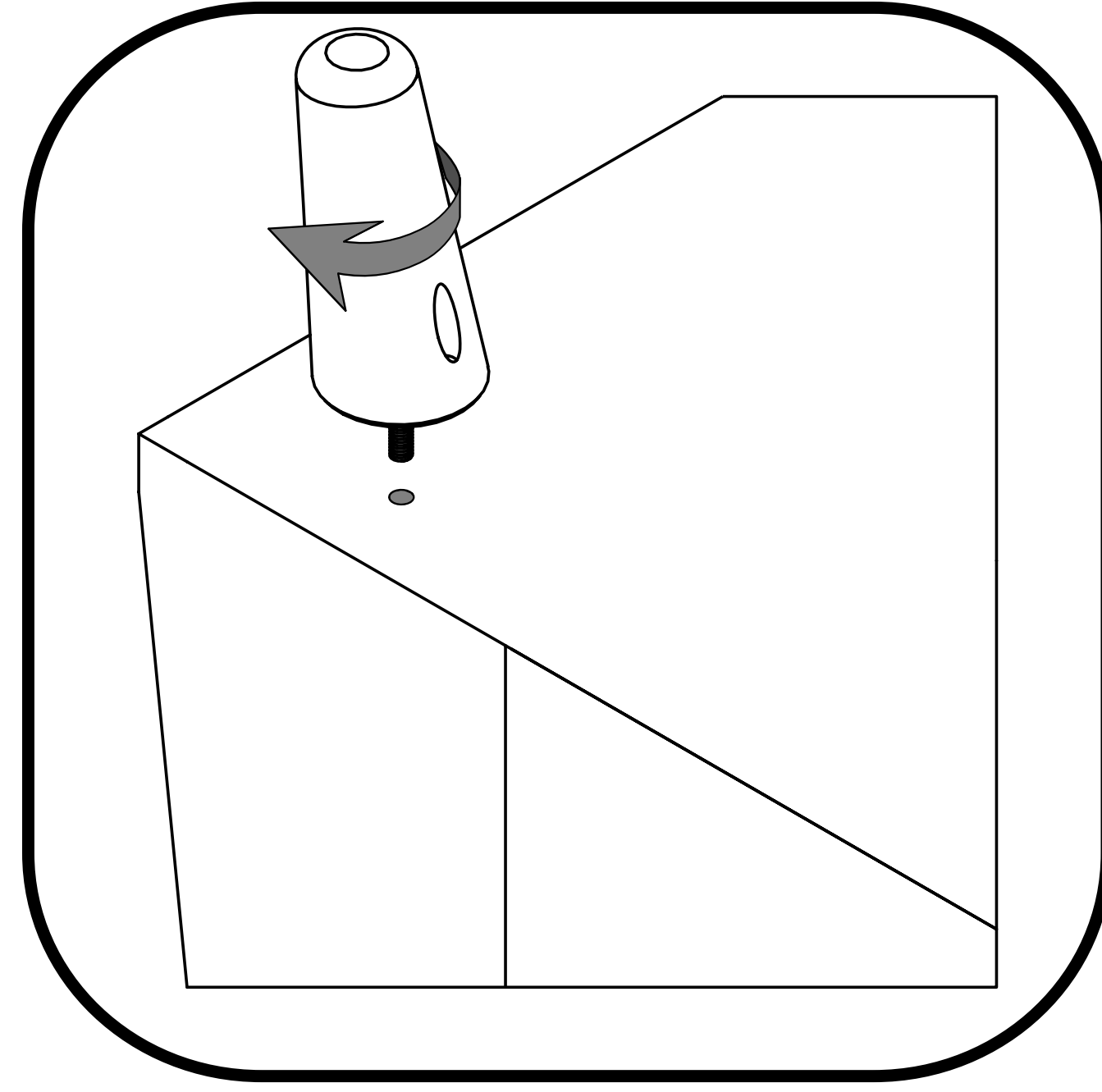

- SCREW FOOT INTO METAL INSERTS UNTIL HAND TIGHT

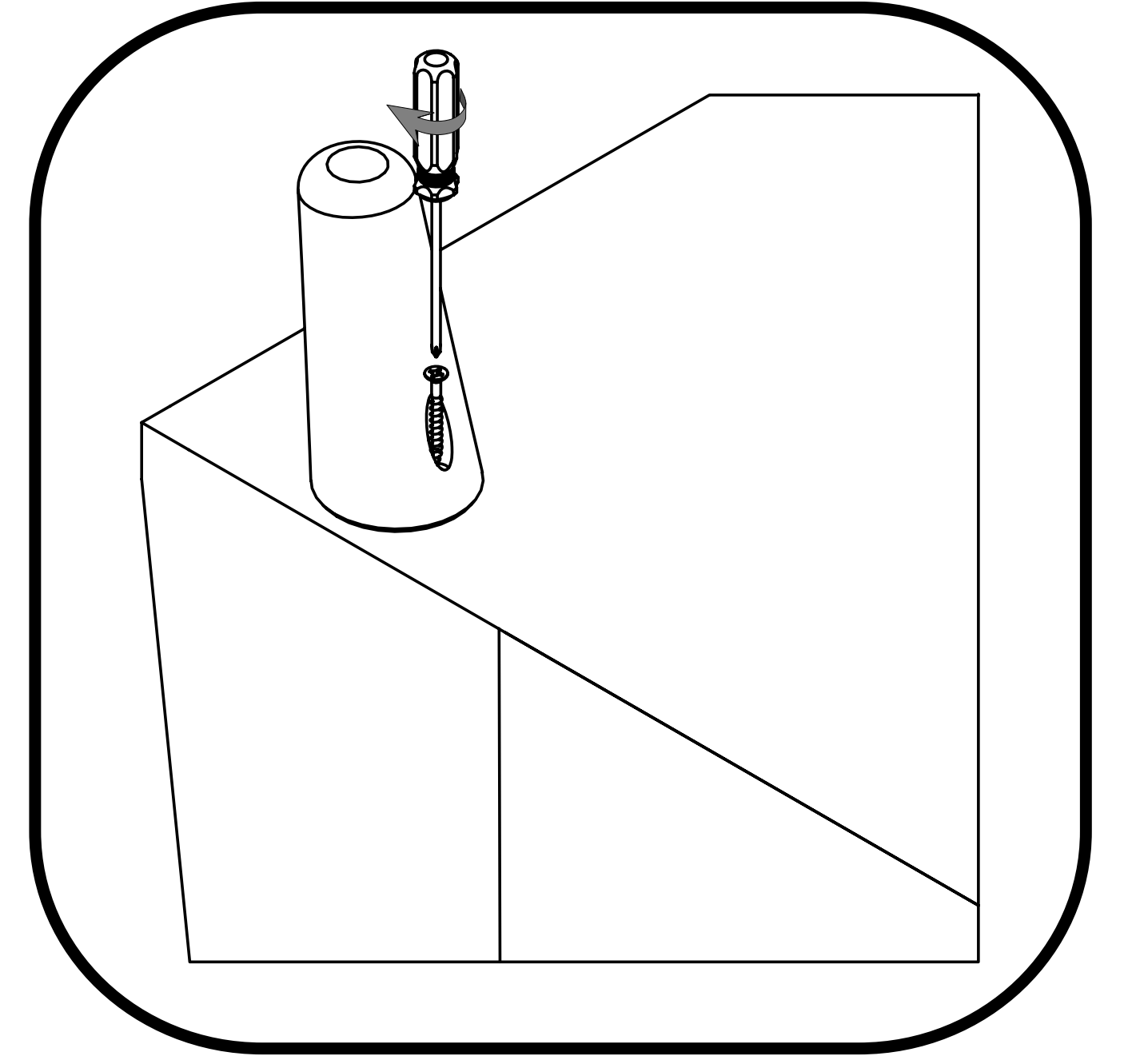

- IF NECESSARY, CHECK ORIENTATION OF FOOT
- IF PROVIDED, INSERT LOCKING SCREW

FOOT TYPE 2:

REMOVE TRANSPORT GLIDE - UNSCREW ANTI-CLOCKWISE

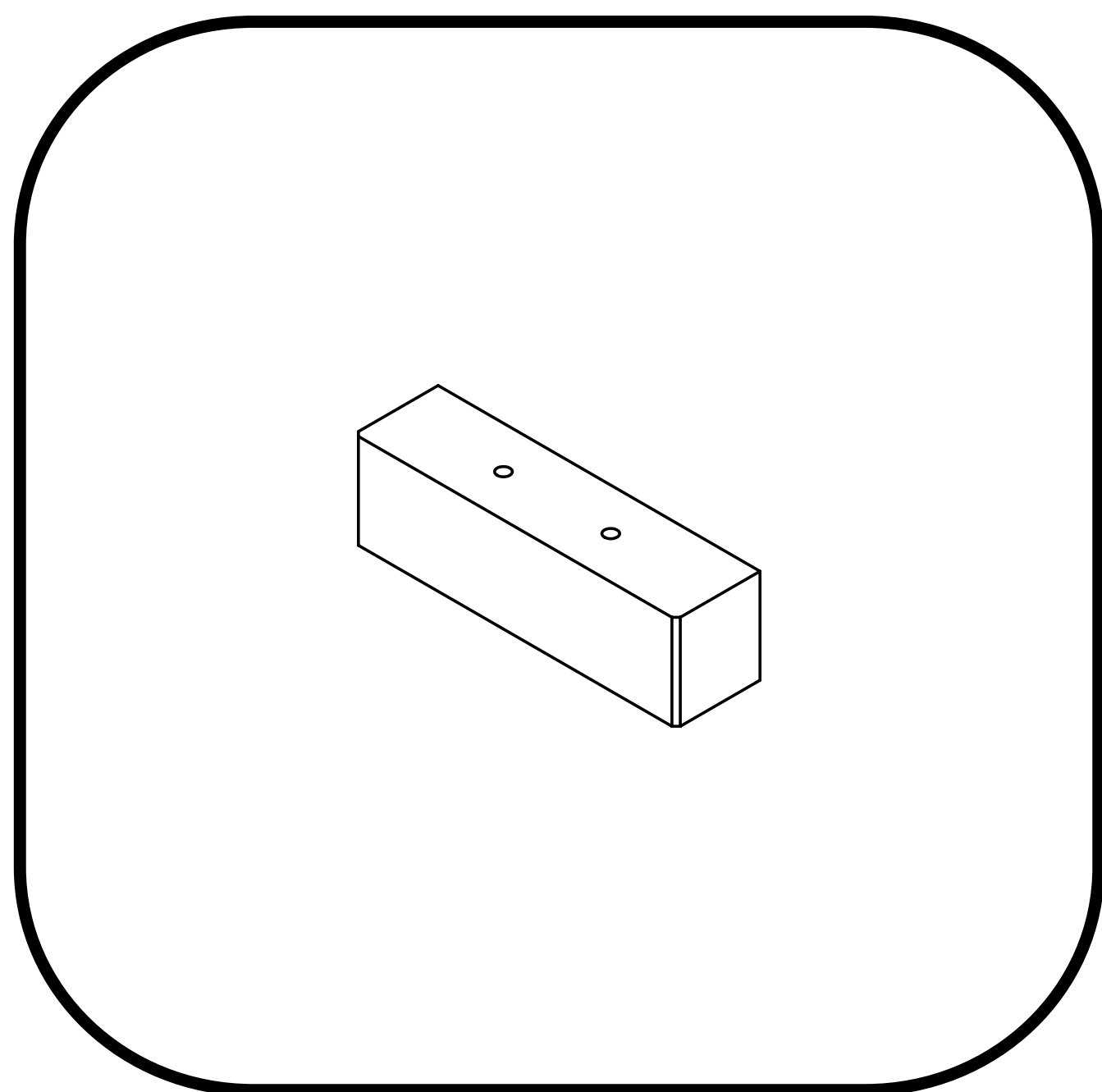

- UNPACKAGE FOOT AND CHECK FOR DAMAGES

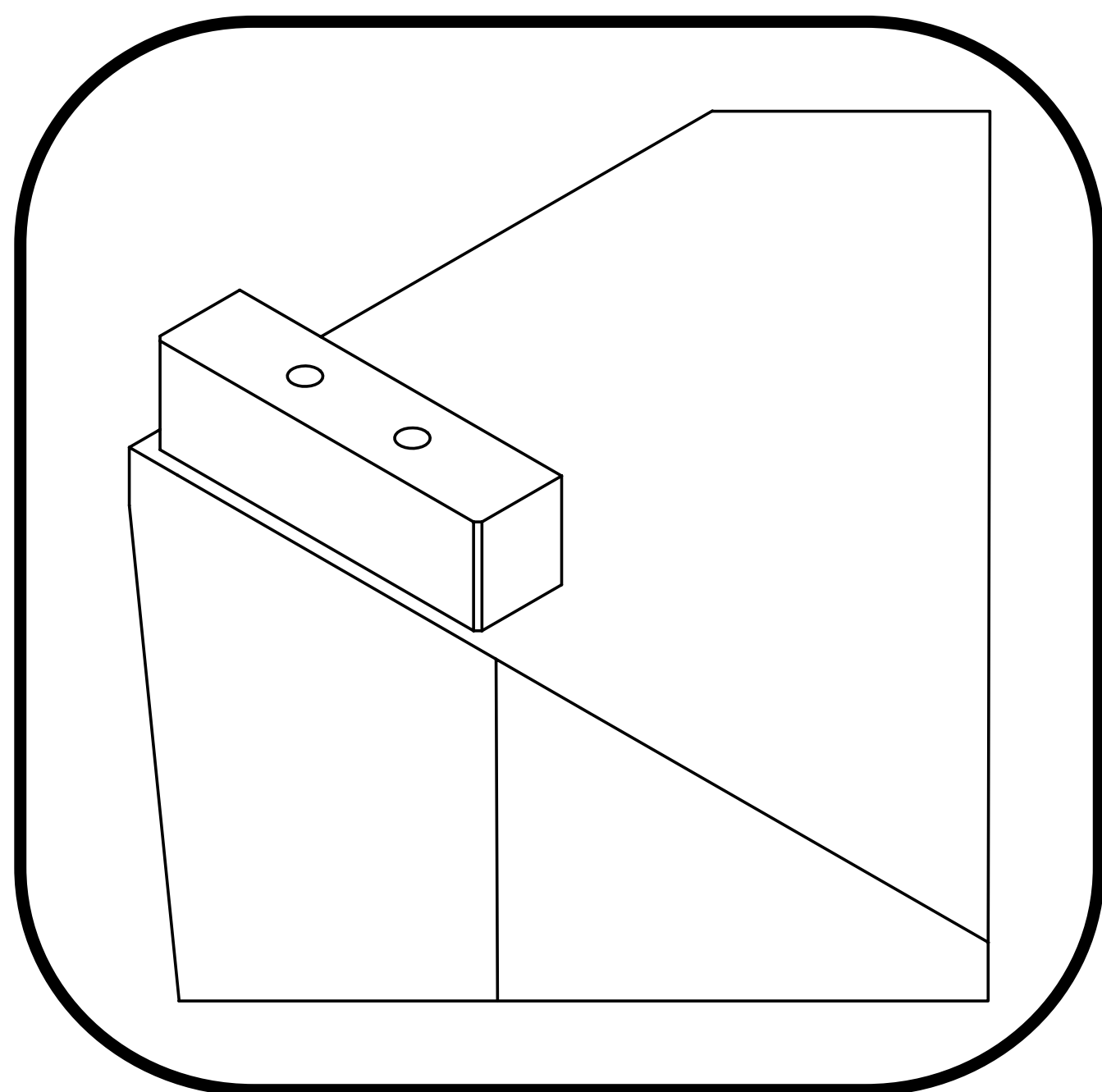

- PLACE FOOT INTO POSITION

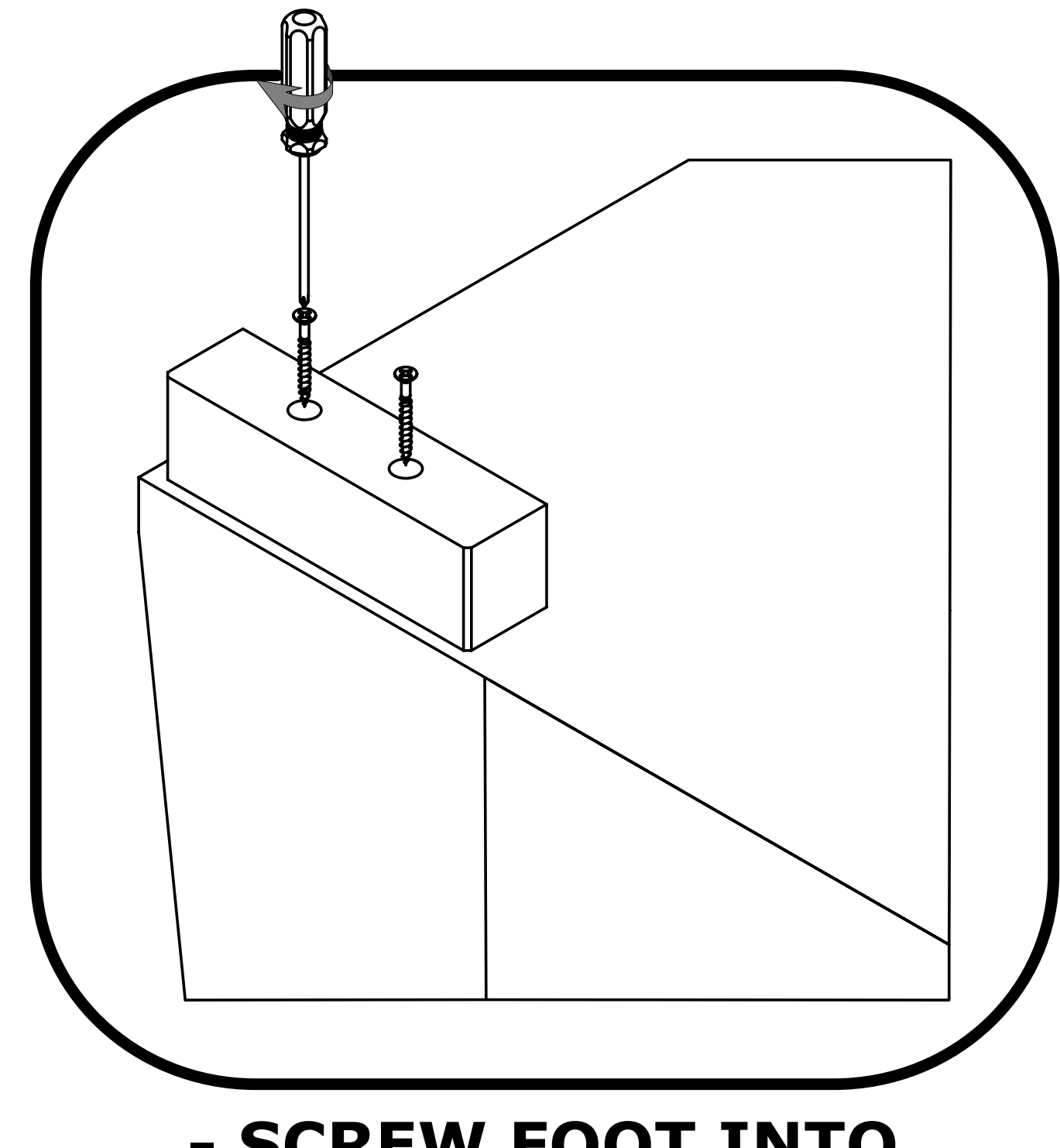

- SCREW FOOT INTO POSITION USING SCREWS PROVIDED

FOOT TYPE 3 - MODULAR UNITS:

REMOVE TRANSPORT GLIDE - UNSCREW ANTI-CLOCKWISE

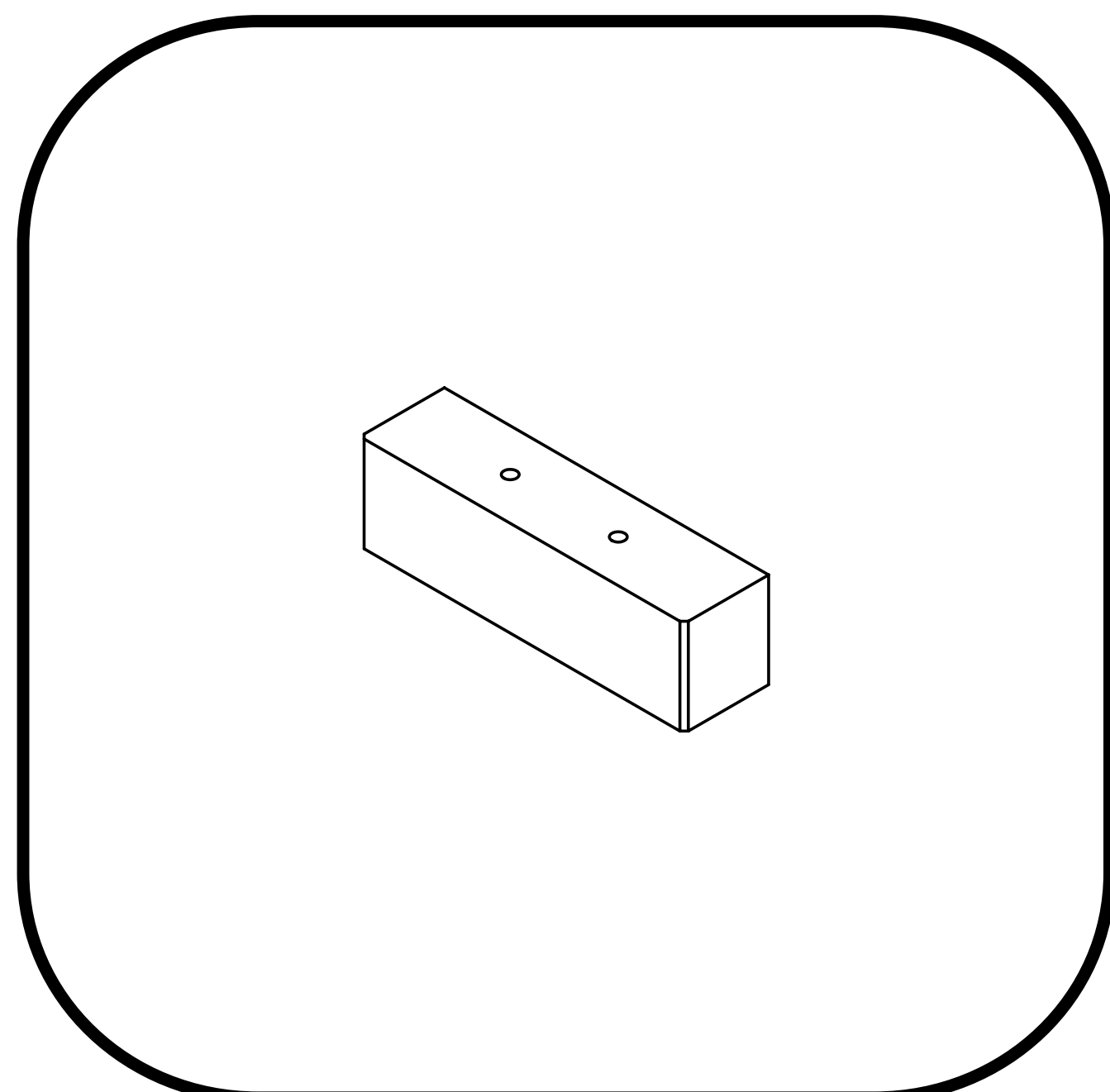

- UNPACKAGE FOOT AND CHECK FOR DAMAGES

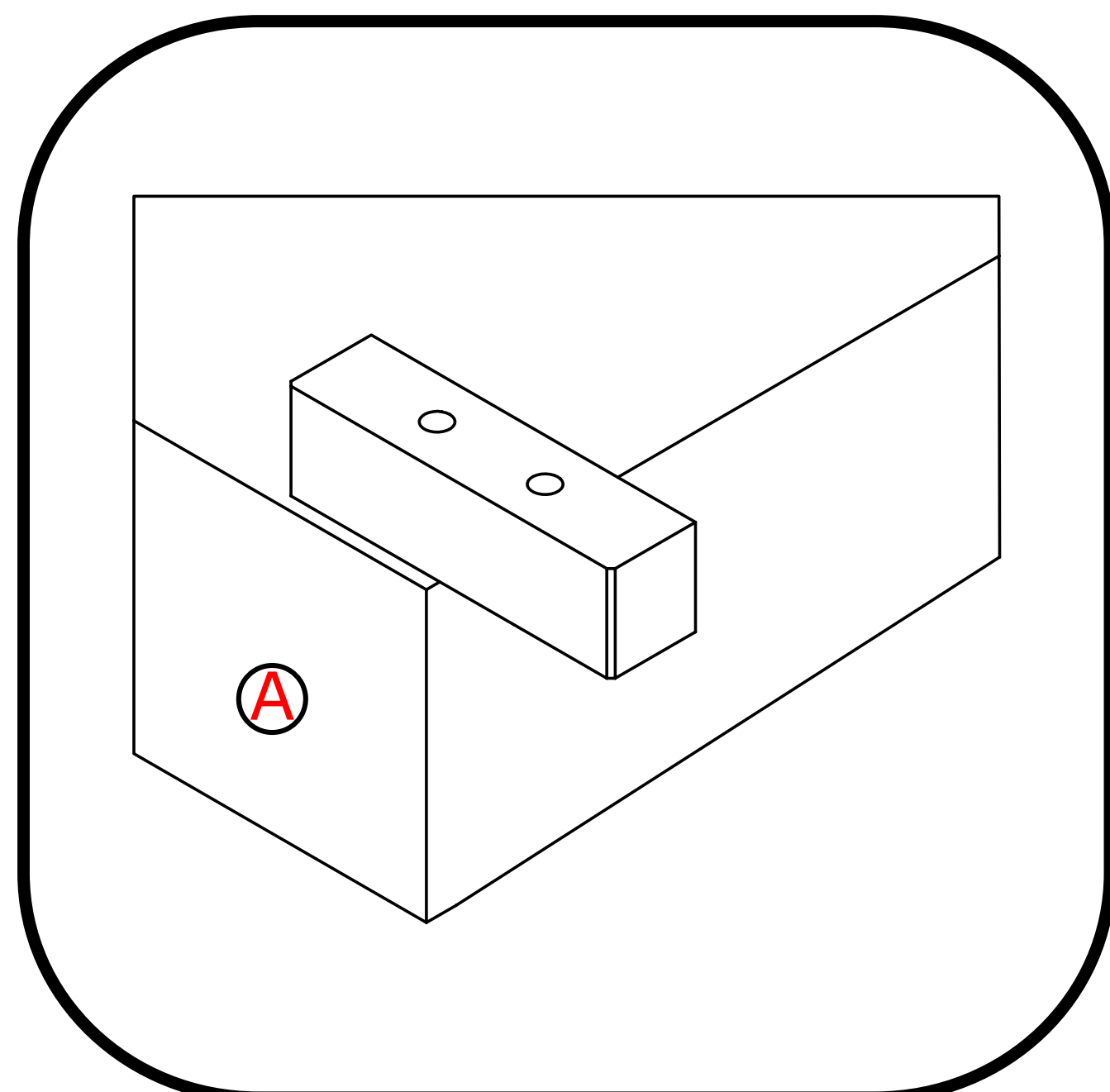

- PLACE FOOT INTO POSITION ON **PART A**

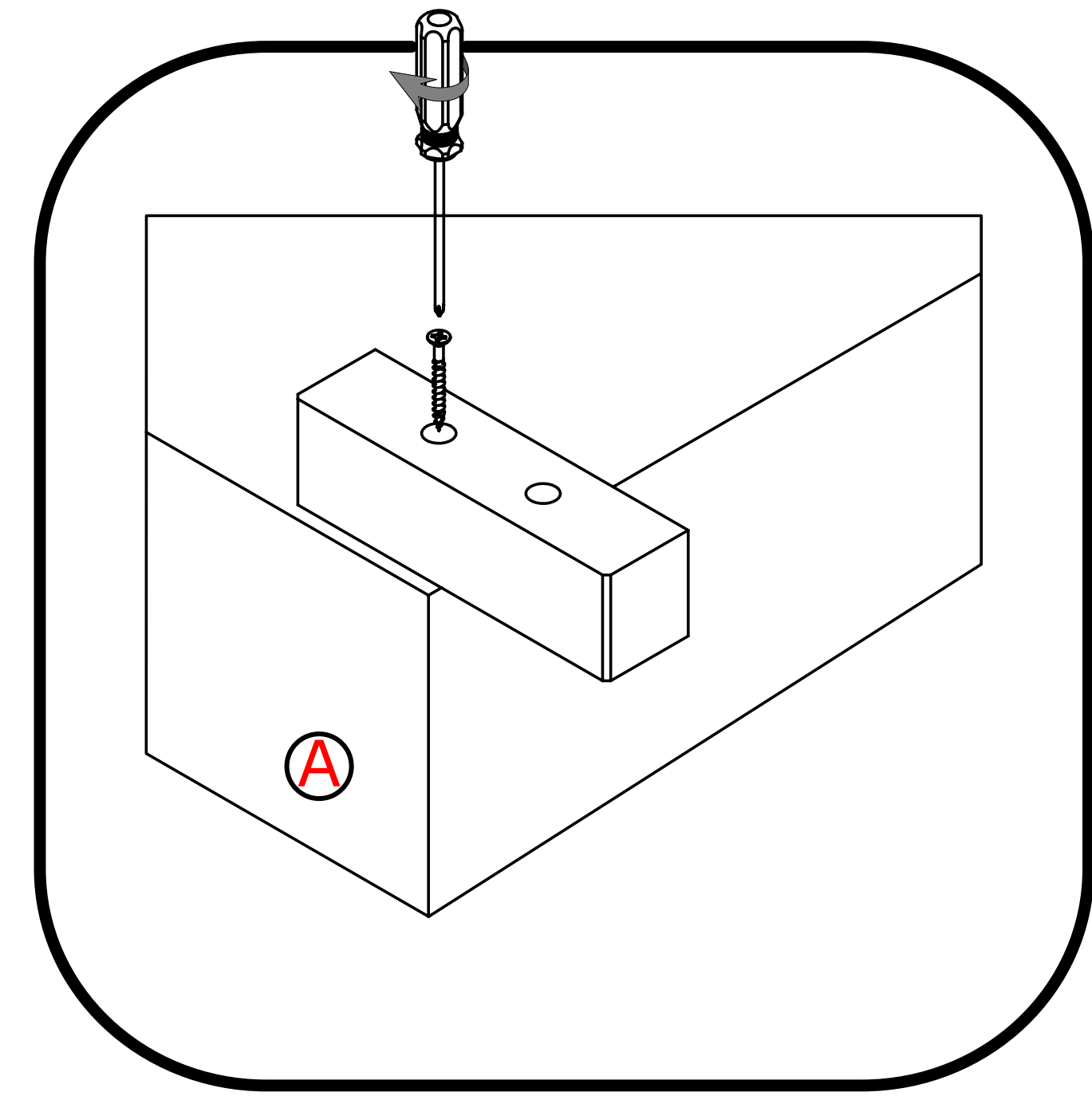

- SCREW FOOT INTO POSITION ON **PART A** USING SCREWS PROVIDED

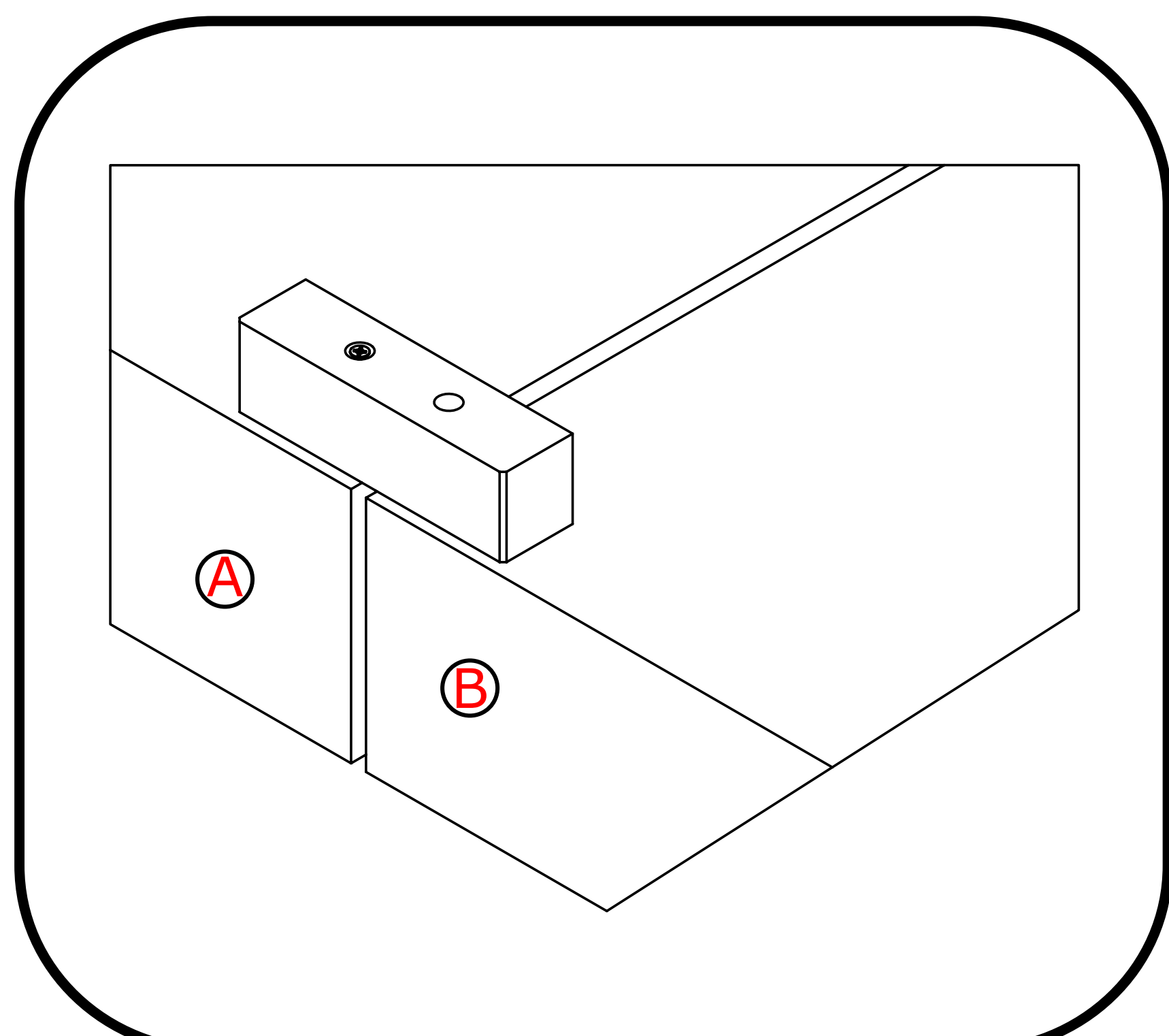

- ALIGN PART A OF SOFA WITH **PART B**
- ALIGN FOOT WITH **PART B**

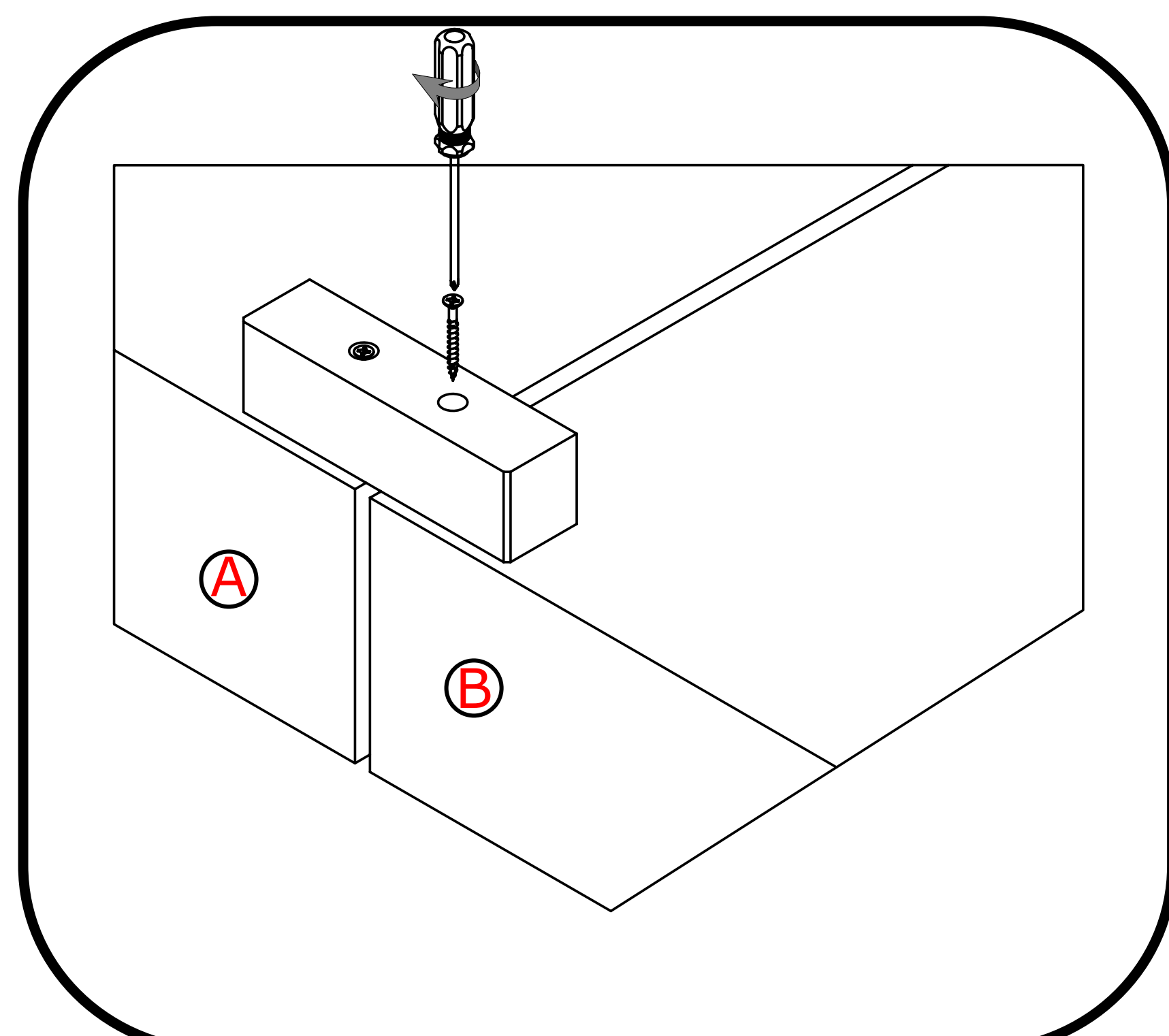

- SCREW FOOT INTO POSITION ON **PART B** USING SCREWS PROVIDED

WARNING:

- DO NOT OVERTIGHTEN FEET
- DO NOT OVERTIGHTEN FIXING SCREWS