

Parts and Damage Replacement Procedure

1. Please inspect your purchase immediately.
2. This procedure covers product purchased from an authorized Roundhill Reseller and was received in its originally sealed carton.
3. If you find a part missing or damaged, you have a 30-day window in which to order a replacement part from the date on your purchase receipt.
4. You have 3 ways to do this. You will need a copy of your purchase receipt.
 - a. By Fax: Fax the parts order form below and along with your receipt to 614-878-7918
 - b. By Email: Email the order form and along with your receipt to: parts@roundhillfurniture.com
 - c. By Mail: Fill out the parts order form below and along with a copy of your receipt send it to Roundhill furniture parts department 3640 Zane Trace Drive, Columbus OH 43228
5. Once this order is sent in, you will be notified if the part(s) you are requesting can or cannot be shipped within 7-10 business days.

**A COPY OF YOUR PURCHASE RECEIPT OR INVOICE MUST BE ATTACHED TO THIS ORDER FORM.
NO ORDERS WILL BE PROCESSED WITHOUT PROOF OF PURCHASE.**

NAME: _____

ADDRESS: _____ (No Post Office Boxes)

CITY: _____ STATE: _____ ZIP: _____

PHONE: _____ FAX: _____

EMAIL: _____

REASON FOR REPLACEMENT/PLEASE CHECK APPROPRIATE BOX.

- () Damaged /scratched, cracked, broken, crushed, etc.
- () Mechanical malfunction/ drawer glides, swivel mechanisms, lid stays, etc.
- () Missing pieces
- () Unfinished surface
- () Wrong color
- () Other

IF MORE THAN ONE MODEL NUMBER IS LISTED ABOVE, PLEASE SPECIFY THE EXACT MODEL NUMBER OF YOUR ITEM IN THE SPACE PROVIDED BELOW.

Model Number	Part Letter Code	Quantity



ASSEMBLY INSTRUCTIONS

Reading struction carefully priorto assembly





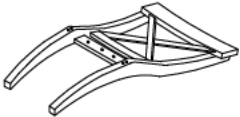
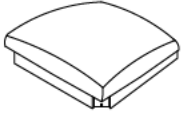

Thank you for purchasing this quality product. Check carefully for small parts which may have come loose during shipment.

Remove all components from pack and place table top upside down on softsurface such as carpet or clothto prevent scratching the finish. Identify and count all parts as specified below. Do not tighten bolts until assembly is complete.

"PART LISTS"

STT	DESC	OUTLOOK	Q'TY
1	CHAIR BACK		1pc
2	SEAT FRAME		1pc
3	CHAIR LEGS		2pc

"HARDWARE LISTS"

STT	OUTLOOK	SIZE	Q'TY
A		5/16" x 3" BOLT	4pcs
B		5/16"x2 " BOLT	4pcs
C		5/16"x1 1/2" BOLT	2pcs
D		5/16" SPRING WASHER	10pcs
E		5/16"x19mm LOCK WASHER	10pcs
F		4mm ALLEN WRENCH	1pc



STEP 1

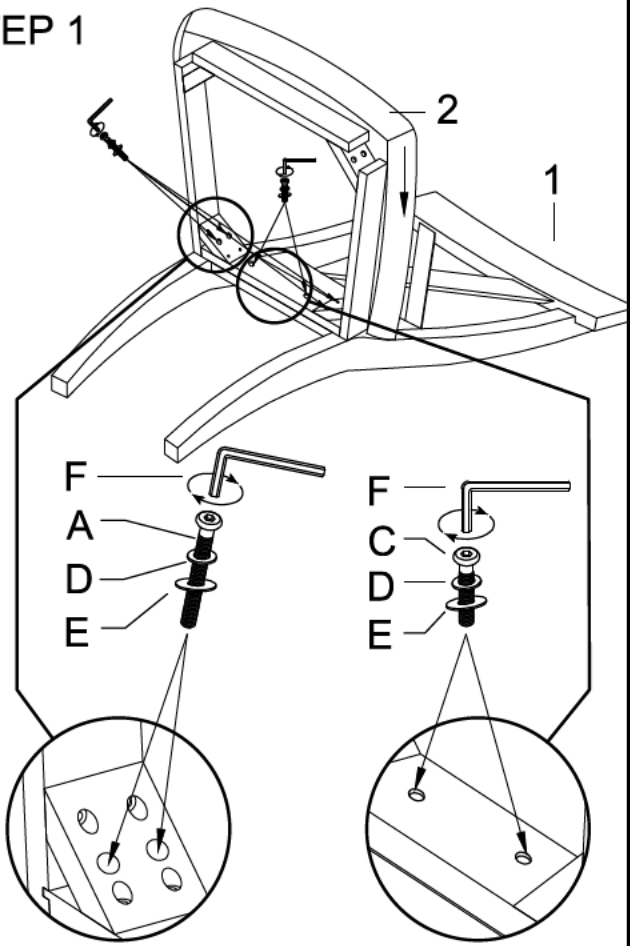

STEP 2

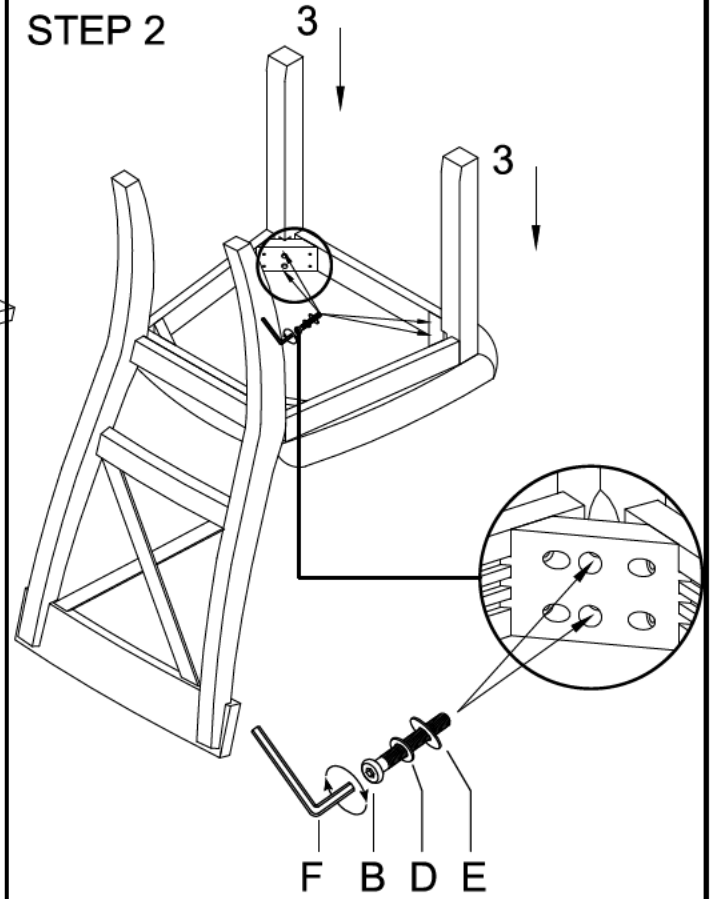

FINAL

