

NOTICE

- * Please make sure that you have all parts indicated and they are in good condition before you begin assembly of this item. Refer to part list and hardware list below for guidance.
- * This item should be assembled on a soft surface to prevent scratching the finish during assembly.
- * This item may require periodic tightening.
- * If you are having difficulty, our friendly Customer Care team is always here to help.











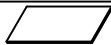

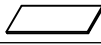
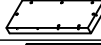
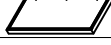

PREPARATION

- * Before beginning assembly of product, make sure all parts are present. Compare parts with part contents list and hardware contents list.
- * If any part is missing or damaged, do not attempt to assemble the product.
- * Estimated Assembly Time: 30 minutes.
- * Tools Required for Assembly : Allen Key (included), Phillips screwdriver (not included)

CARE AND MAINTENANCE

Adhesive felt pads should always be applied to areas of furniture which make direct contact with flooring, said application will prevent damage to the furniture and or surfaces on which the furniture lies. Objects placed on articles of furniture should rest on non abrasive material as to prevent damage to the wood finish. Wipe up spills immediately and avoid common hazards such as hot dishes, harsh solvents and abrasives. Cleaning should be done with a soft lint free cotton cloth dampened with water or furniture polish.

Part List and Hardware List



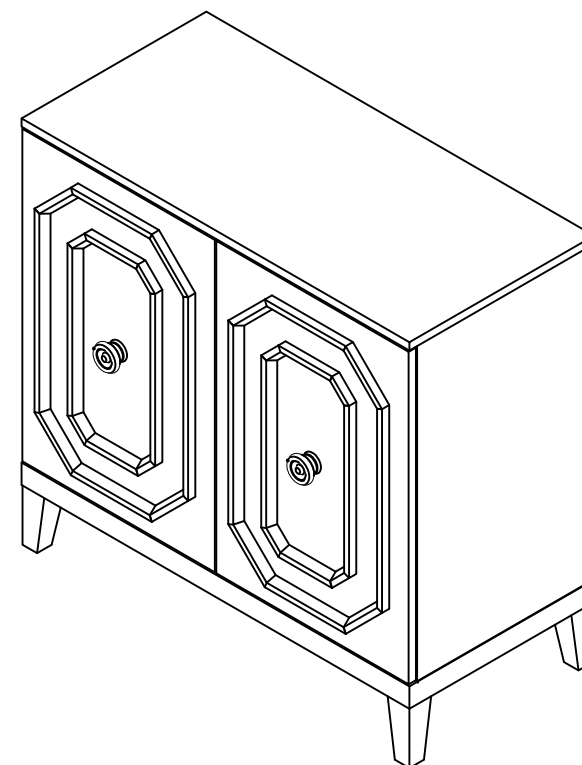

PIECE	DESCRIPTION	PICTURE	QUANTITY
A	TOP PANEL		1X
B	FRONT RAIL		1X
C	SIDE PANEL		2X
D	DOOR		2X
E	ADJUSTABLE SHELF		1X
F	BACK PANEL		2X
G	BASE ASSEMBLY		1X
H	LEG		4X
HW1	BOLT 6 x 1 x 40 MM		8X
HW2	ROUND HEAD SCREW 3 x 1 x 13 MM		16X
HW3	CAMBOLT		27X
HW4	CAMLOCK		27X
HW5	HANDLE BOLT		2X
HW6	HANDLE		2X
HW7	HINGE		4X
HW8	SHELF PIN		4X

Product Dimensions: 31 1/2"W x 15"D x 30"H



⚠ WARNING ⚠

WEIGHT CAPACITY: (TOP) 50 LBS; (SHELF) 30 LBS
 WARNING: DO NOT STAND ON THE CABINET
 WARNING: DO NOT OVER TORQUE BOLTS/SCREWS

PIECE	DESCRIPTION	PICTURE	QUANTITY
HW9	DOWEL		8X
HW10	SPRING WASHER		8X
HW11	FLAT WASHER		8X
HW12	ALLEN KEY		1X

PREPARATION

- * Before beginning assembly of product, make sure all parts are present. Compare parts with package contents list and hardware contents list.
- * If any part is missing or damaged, do not attempt to assemble the product.
- * Estimated Assembly Time: 30 minutes.
- * Tools Required for Assembly : Allen Key (included), Phillips screwdriver (not included)
- * If you are having difficulty, our friendly Customer Care team is always here to help.

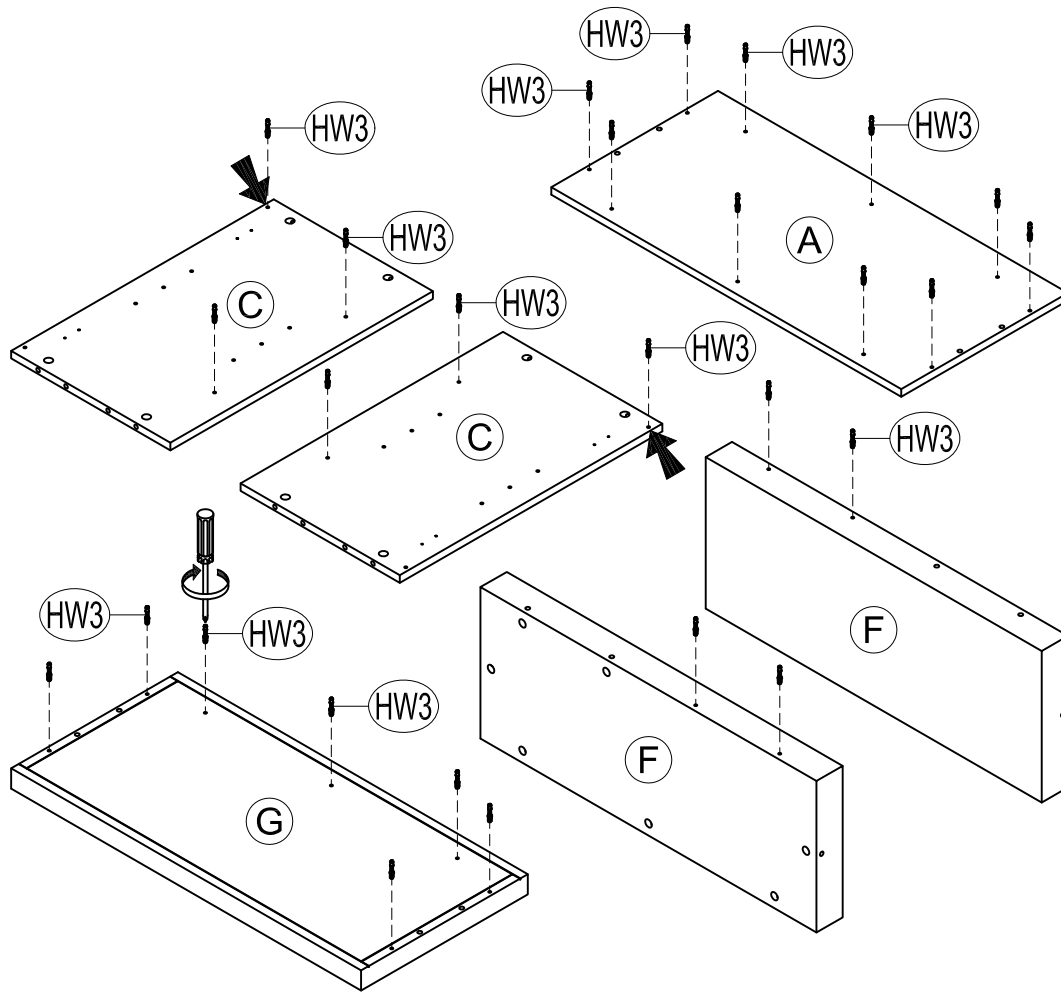

STEP 1 ATTACH CAMBOLT (HW3) TO TOP (A), SIDE AND BACK PANELS (C) & (F) AND BASE ASSEMBLY (G).

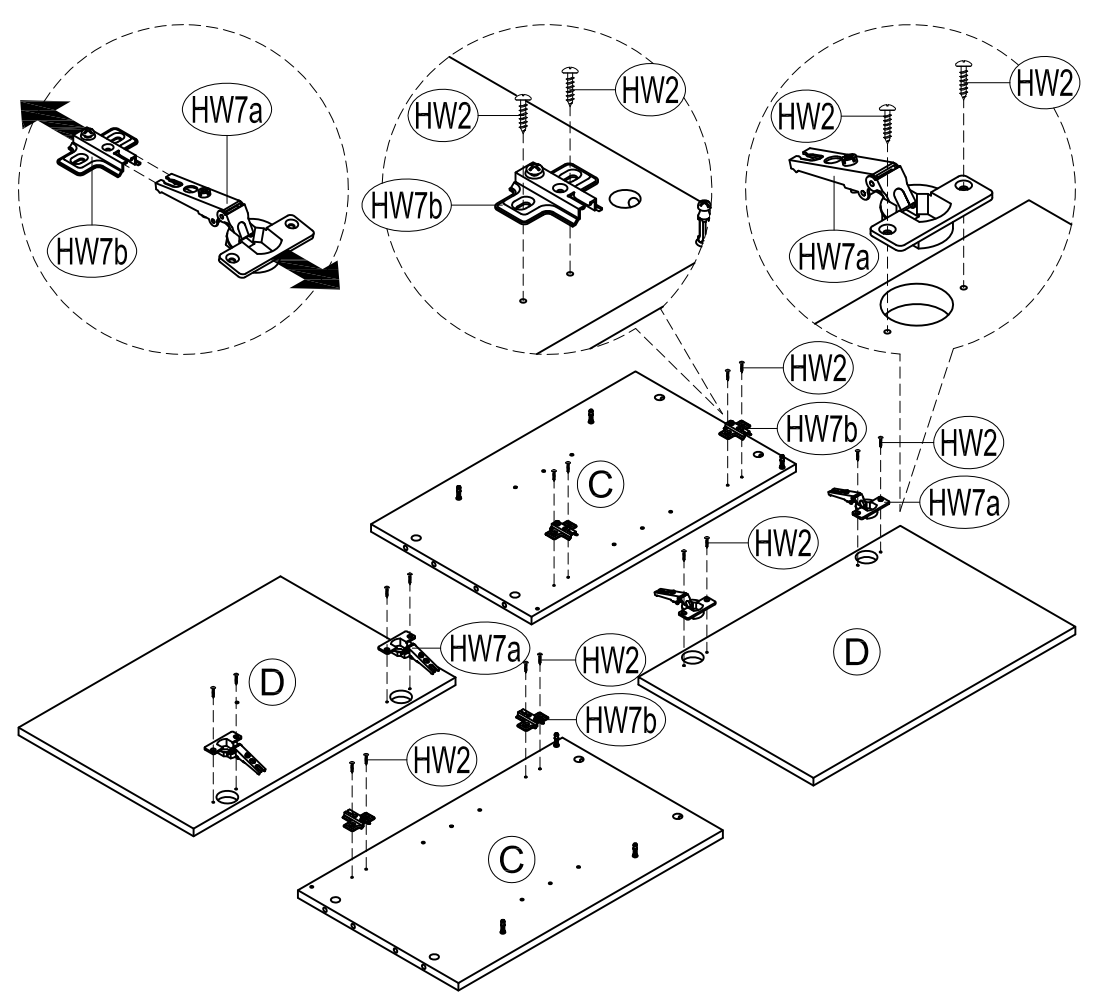

STEP 2 DETACH THE HINGES (HW7). ATTACH HINGES (HW7a) TO DOORS (D), AND HINGE BASES (HW7b) TO SIDE PANELS (C) USING 1/2" ROUND HEAD SCREW (HW2).

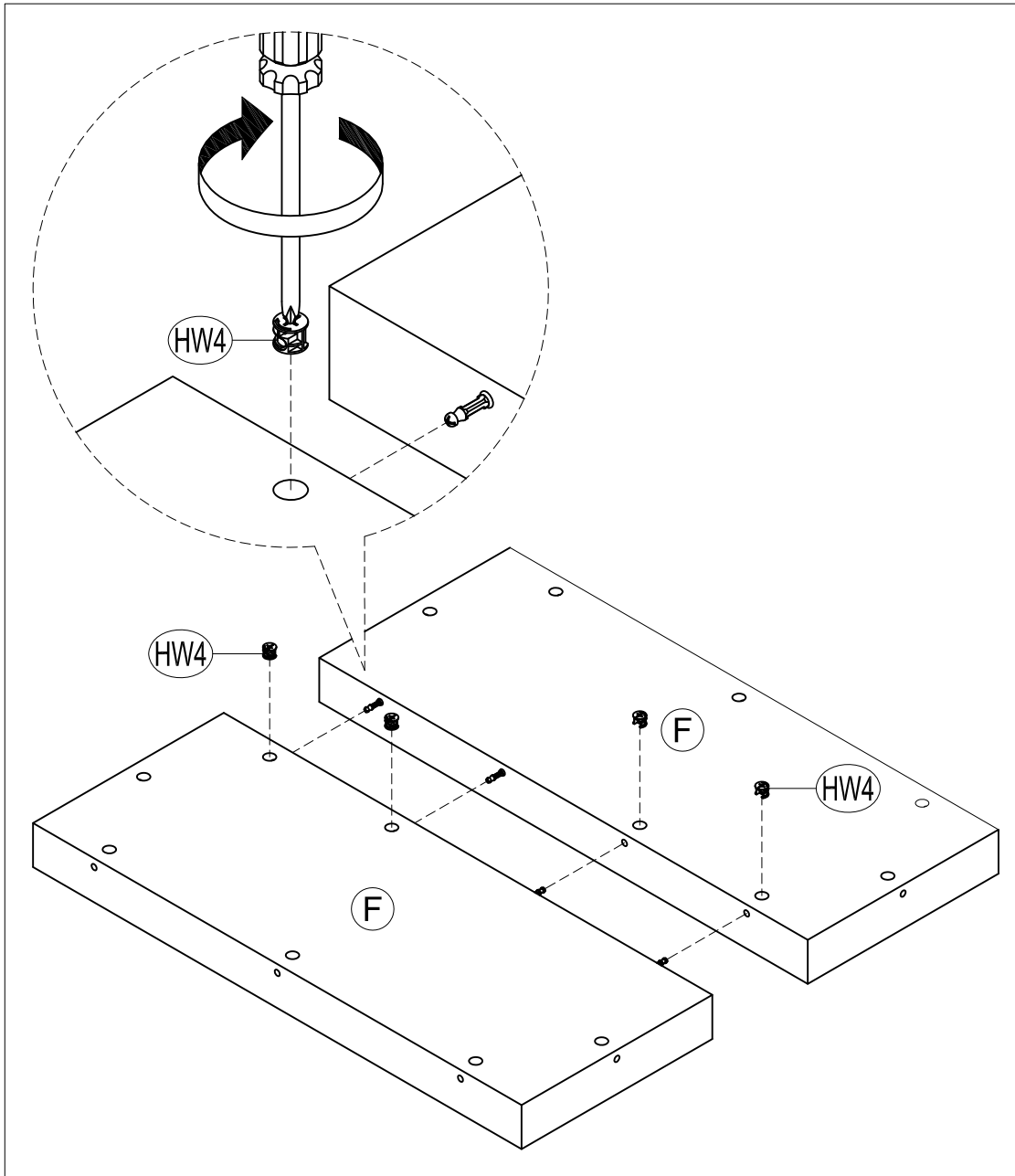

STEP 3 JOIN BACK PANELS (F) USING CAM LOCKS (HW4).

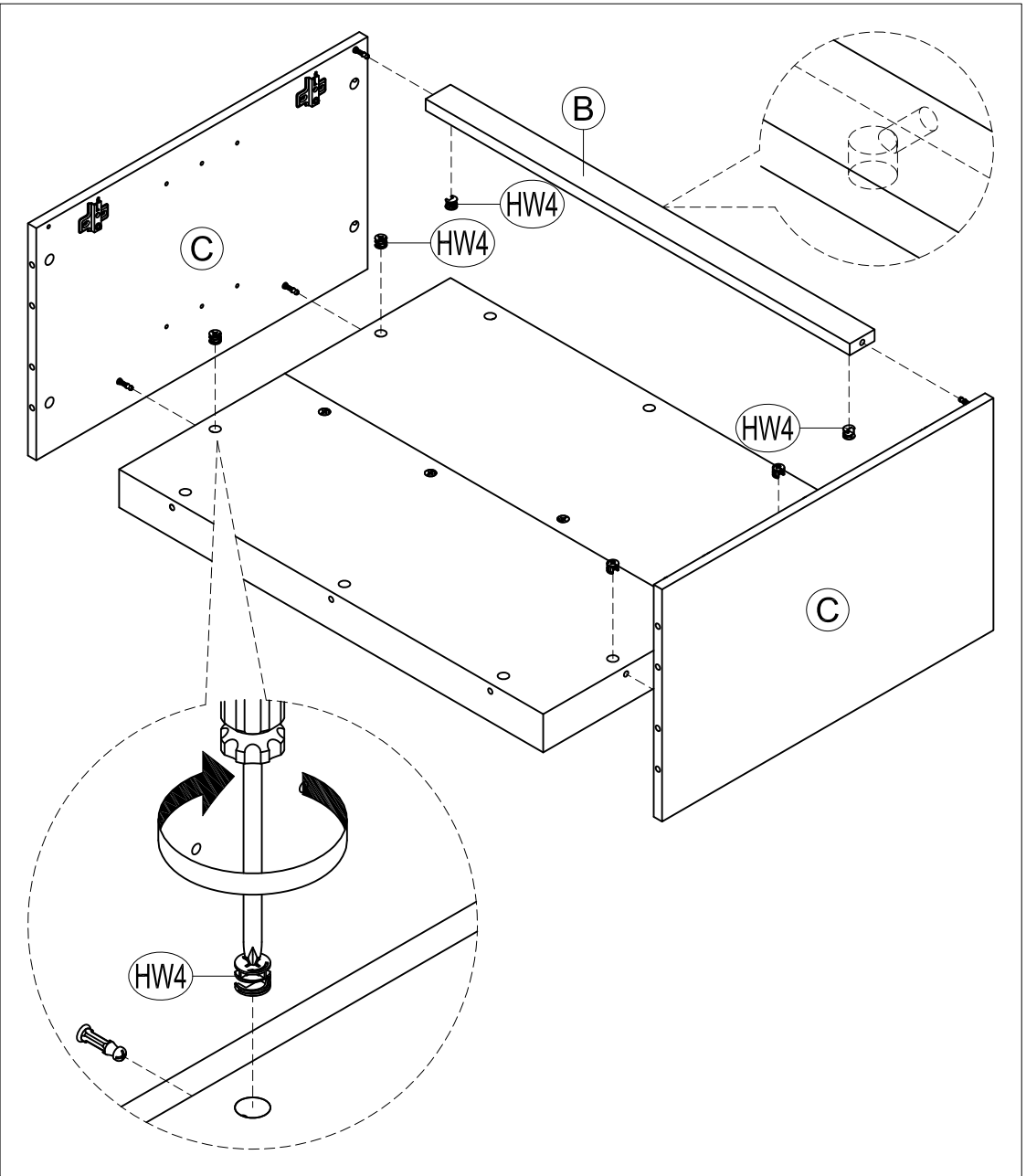

STEP 4 ATTACH SIDE PANELS (C) TO UNIT AND FRONT RAIL (B) USING CAM LOCKS (HW4).

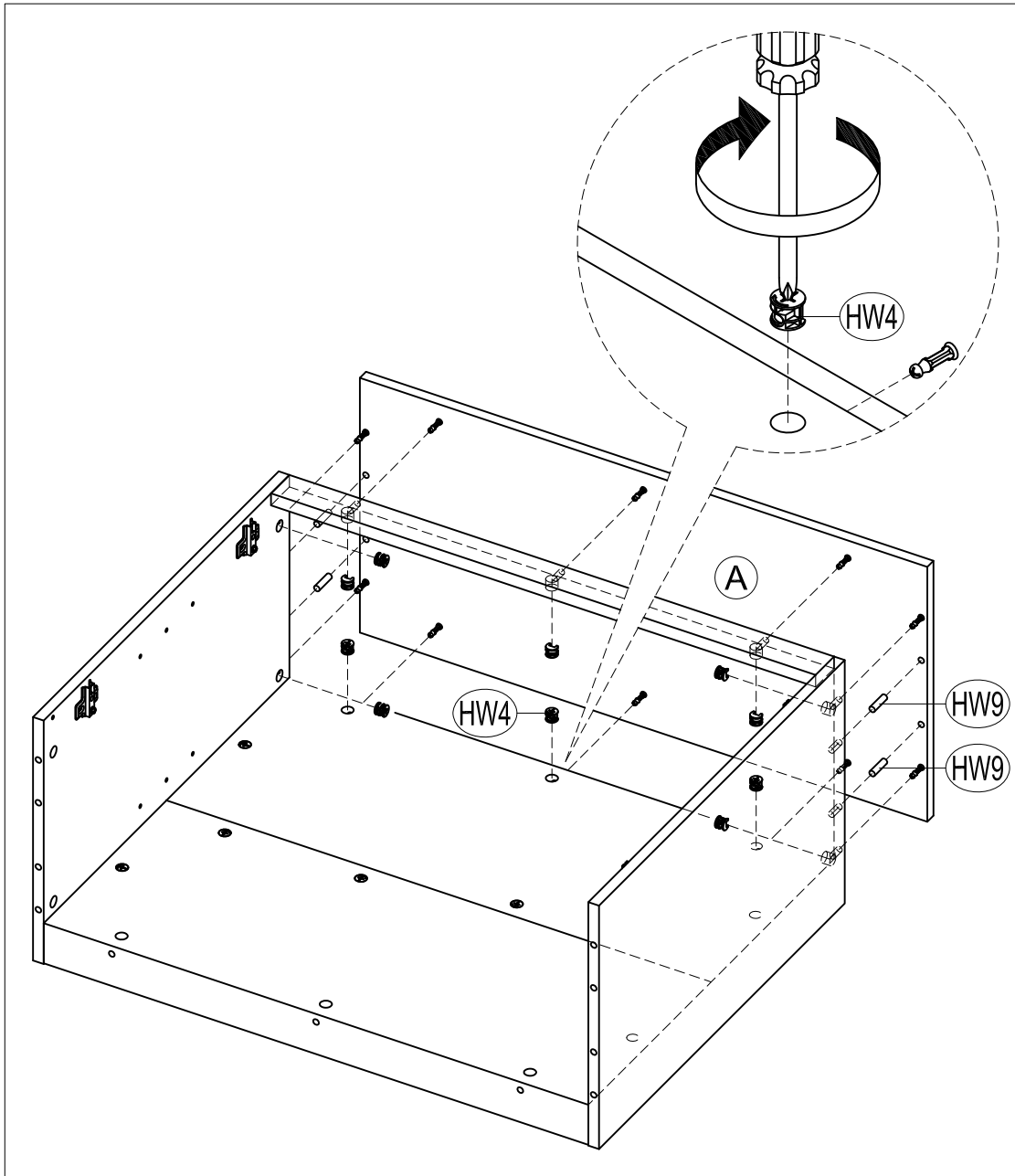

STEP 5 ATTACH TOP PANEL (A) TO UNIT USING CAM LOCKS (HW4) AND DOWELS (HW9).

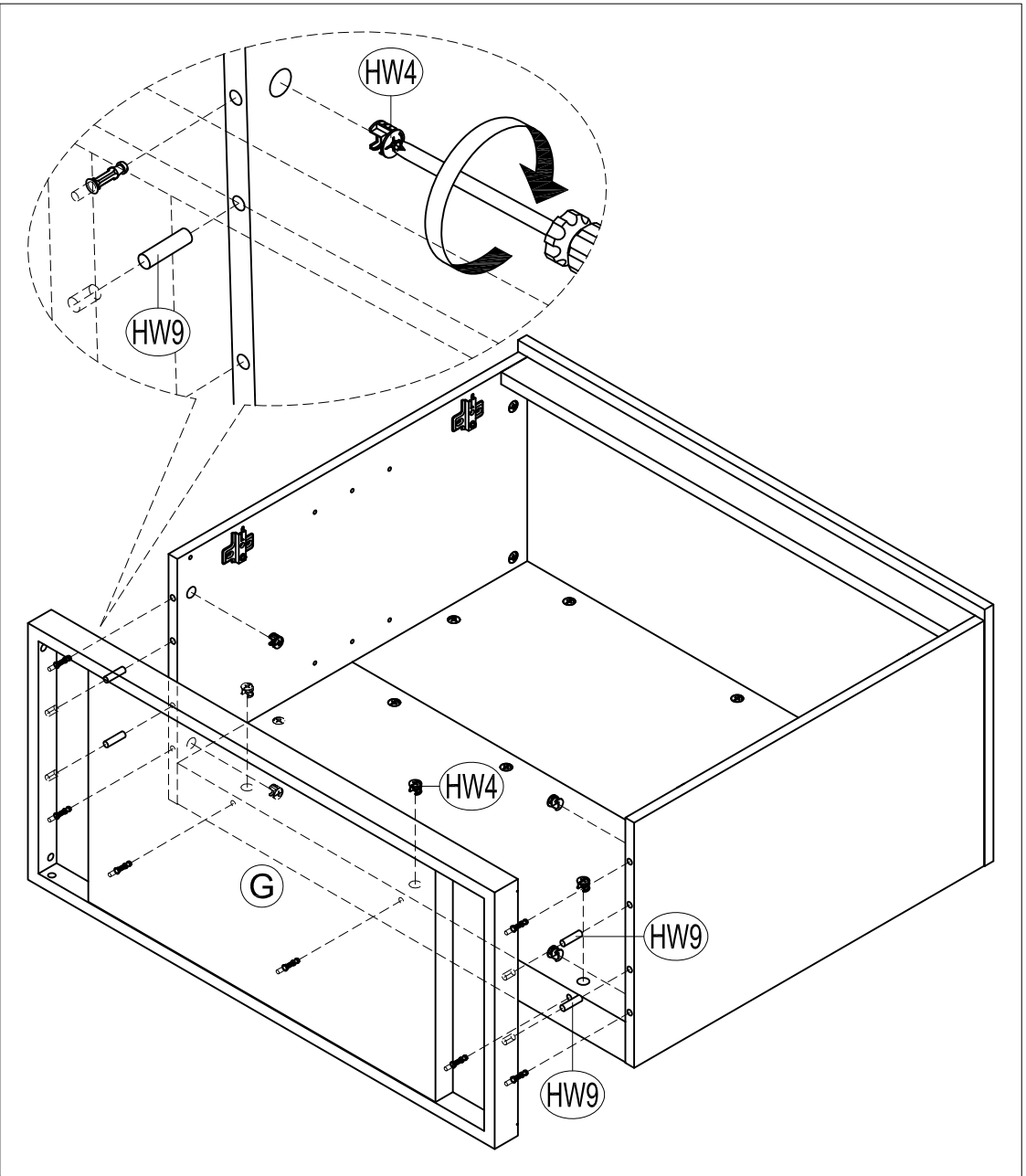

STEP 6 ATTACH BASE ASSEMBLY (G) TO UNIT USING CAM LOCKS (HW4) AND DOWELS (HW9).

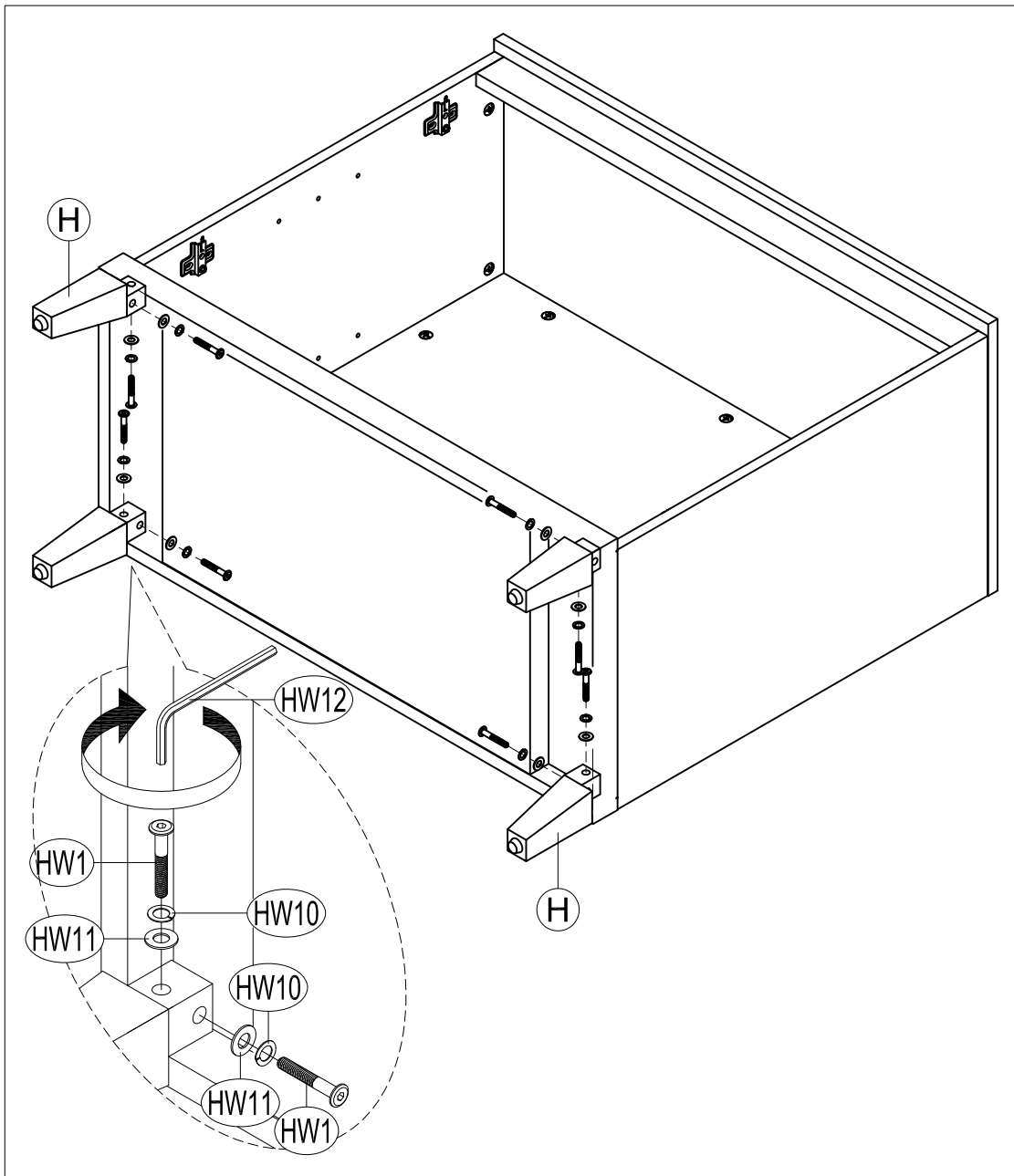

STEP 7 ATTACH LEGS (H) TO UNIT USING BOLTS (HW1), SPRING AND FLAT WASHERS (HW10) & (HW11). TIGHTEN BOLTS (HW1) USING ALLEN KEY (HW12).

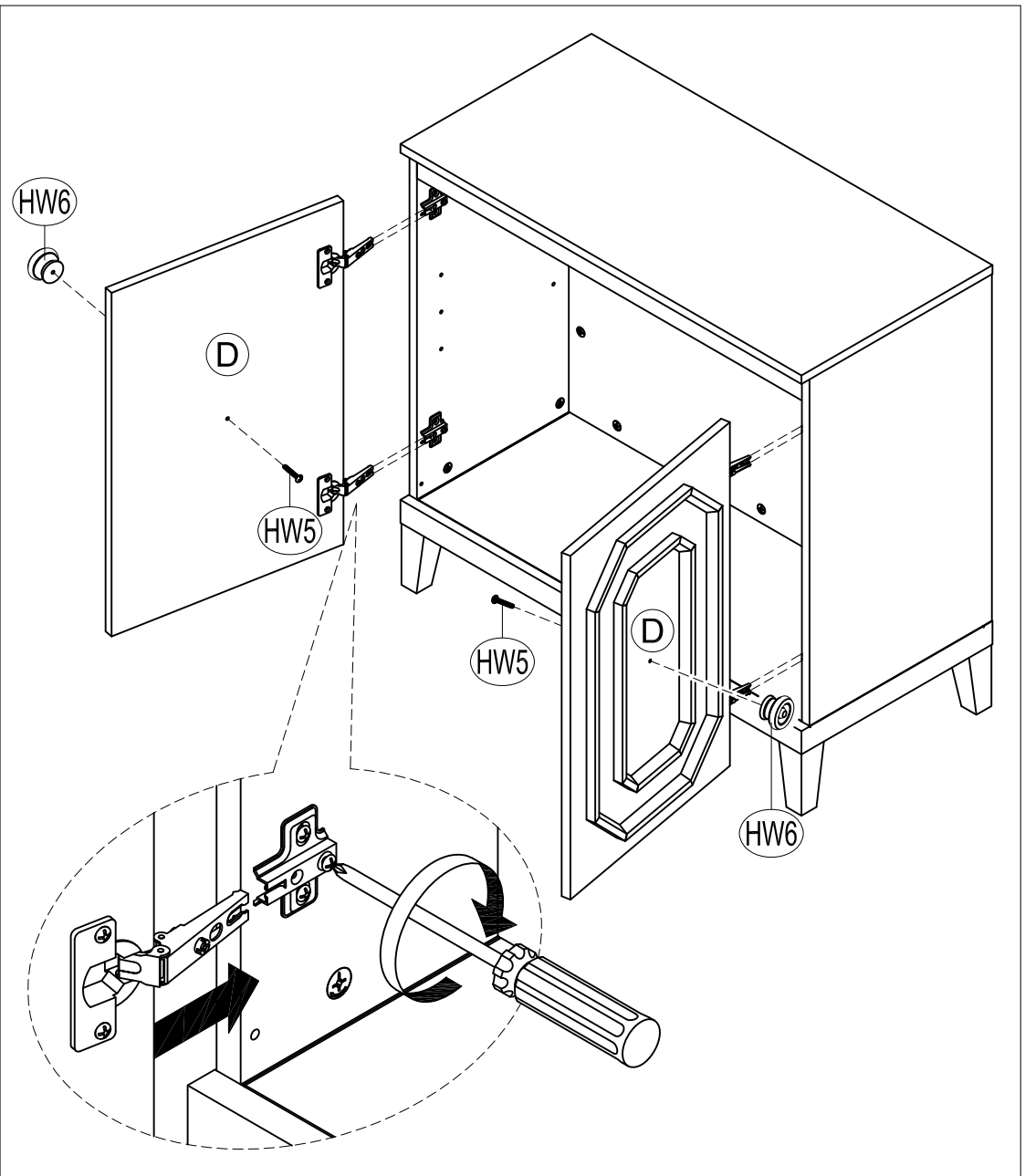

STEP 8 ATTACH HANDLES (HW6) TO DOORS (D) USING HANDLE BOLTS (HW5). ATTACH DOORS (D) TO UNIT BY RE-ATTACHING THE HINGES.

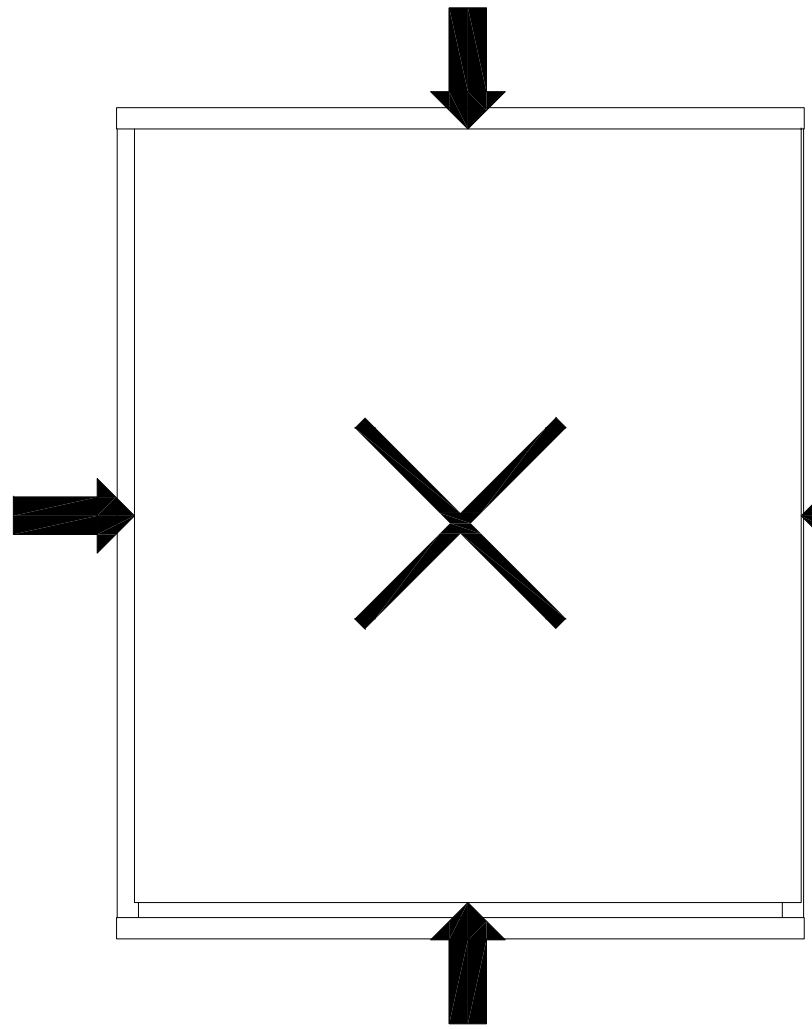

?

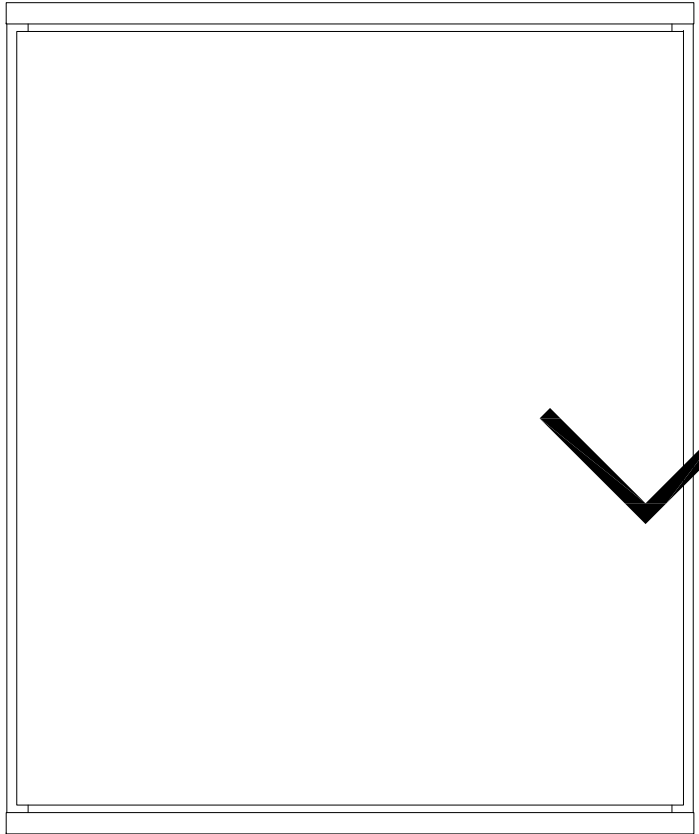

STEP 9 THE GAPS AROUND THE DOOR SHOULD BE BALANCED. IF GAPS ARE NOT BALANCED, PLEASE FOLLOW STEPS 10 THROUGH 12

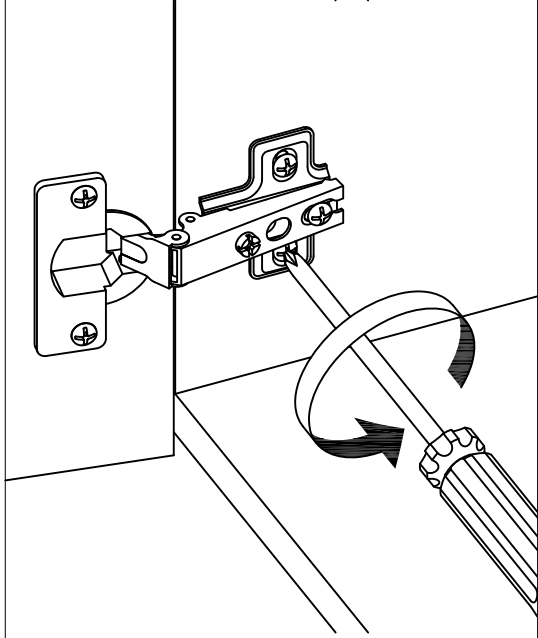
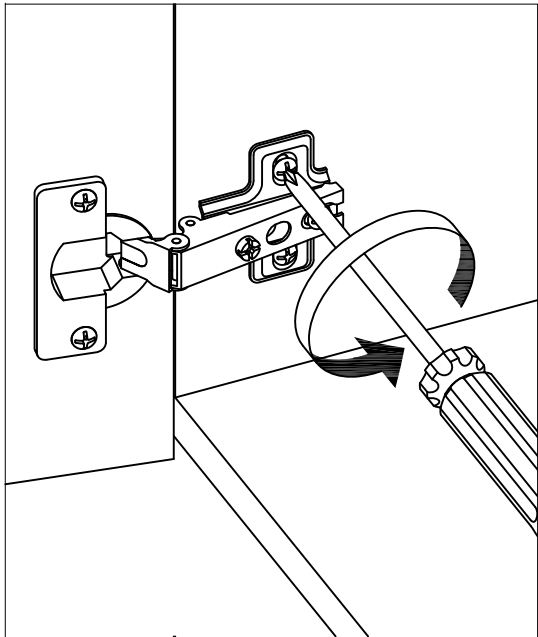

STEP 10.1. IF THE EDGE ON THE TOP OR BOTTOM ARE NOT BALANCED, LOOSEN BOTH HINGE BASE SCREWS.

BEFORE 		AFTER
<p>STEP 10.2.1. IF THE EDGE ON THE TOP IS TOO WIDE THEN SLIDE THE DOOR SLIGHTLY TO THE TOP.</p>		

BEFORE 		AFTER
<p>STEP 10.2.2. IF THE EDGE ON THE BOTTOM IS TOO WIDE THEN SLIDE THE DOOR SLIGHTLY TO THE BOTTOM.</p>		

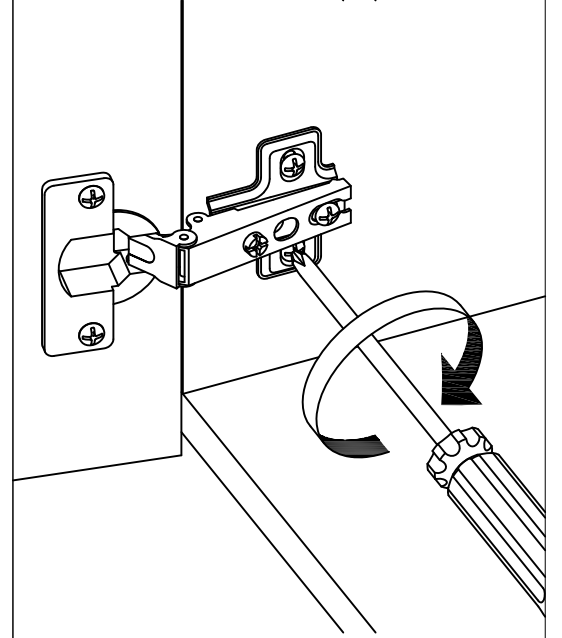
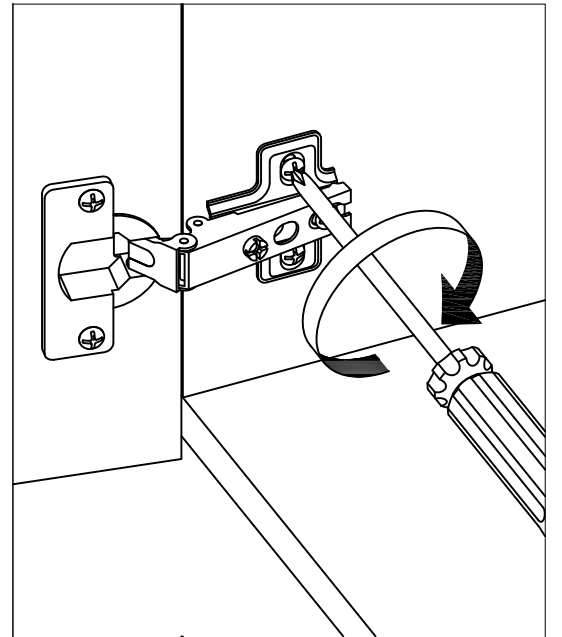

STEP 10.3. TIGHTEN BOTH HINGE BASE SCREWS.

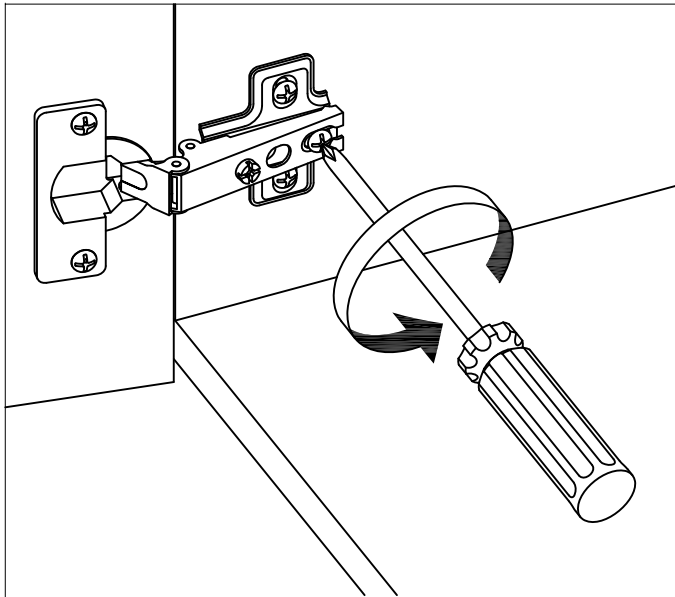

STEP 11.1. IF THE EDGE ON THE LEFT OR RIGHT ARE NOT BALANCED, LOOSEN THE BACK CENTER SCREW.

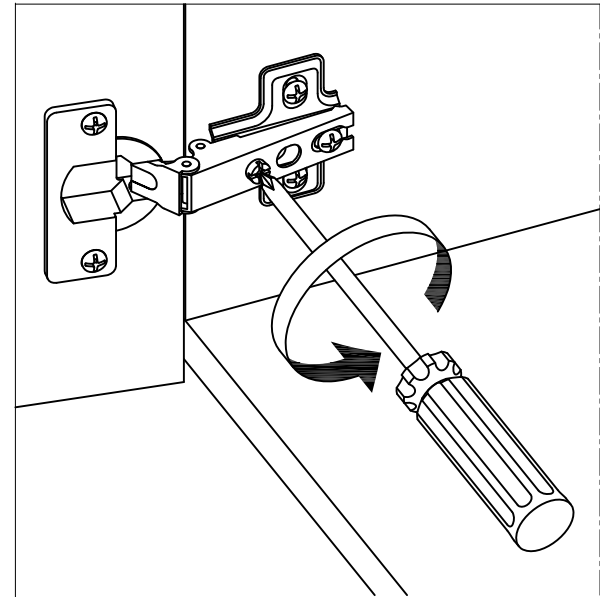

STEP 11.2.1. IF THE EDGE ON THE LEFT SIDE IS TOO WIDE, YOU WILL NEED TO SLIDE THE DOOR SLIGHTLY TO THE LEFT BY TURNING THE FRONT CENTER SCREW COUNTERCLOCKWISE.

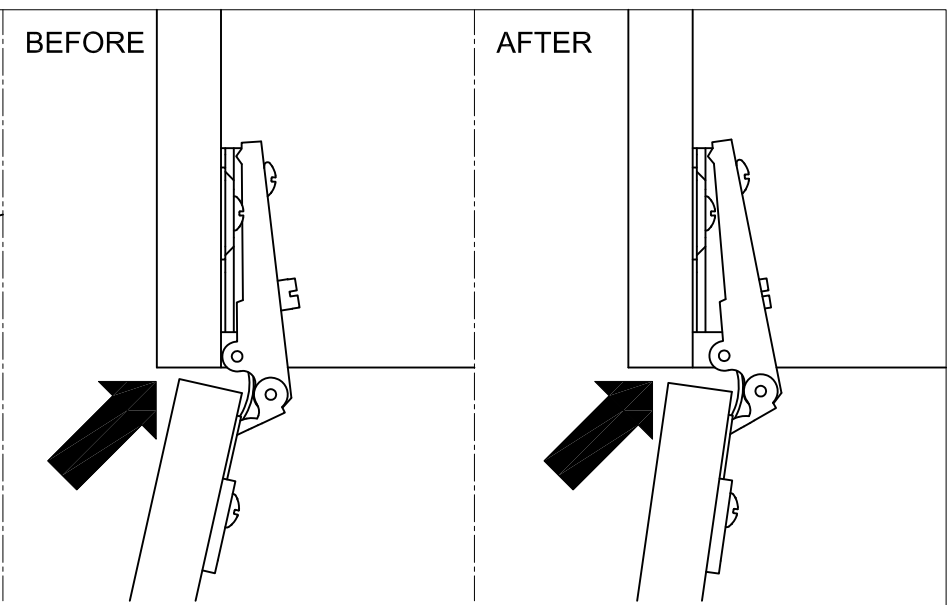
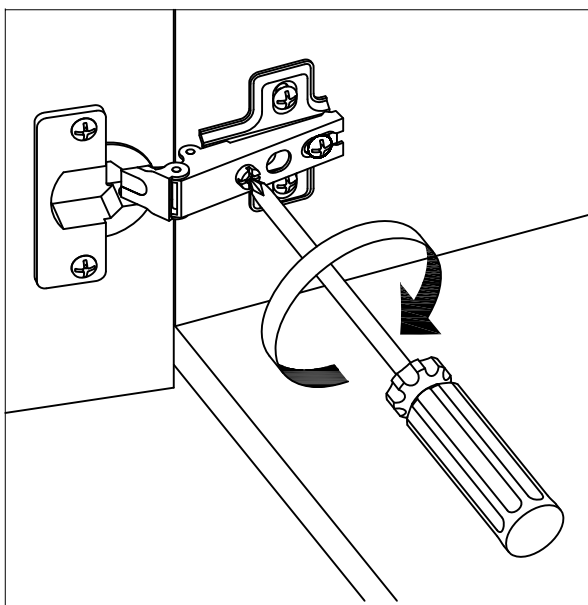
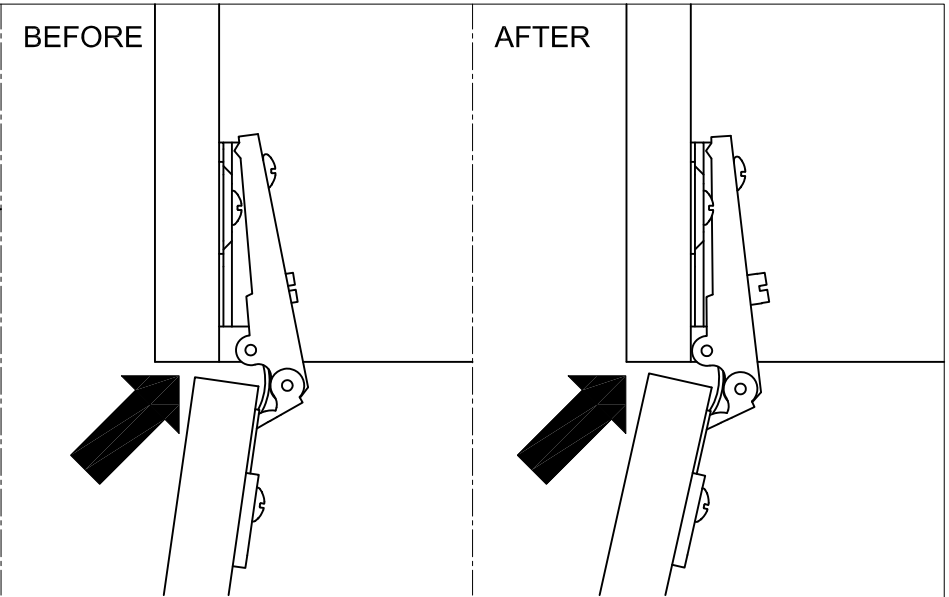

STEP 11.2.2. IF THE EDGE ON THE LEFT SIDE IS TOO NARROW, YOU WILL NEED TO SLIDE THE DOORS SLIGHTLY TO THE RIGHT BY TURNING THE FRONT CENTER SCREW COUNTER CLOCKWISE.

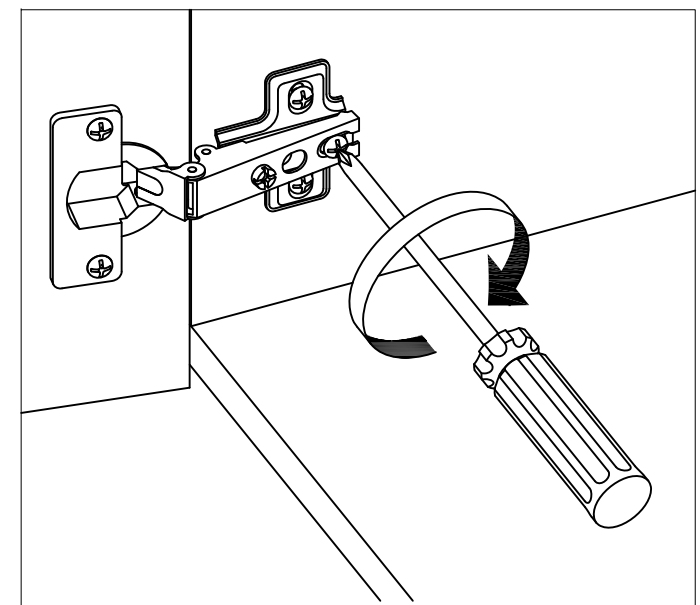

STEP 11.3. TIGHTEN THE BACK CENTER SCREW.

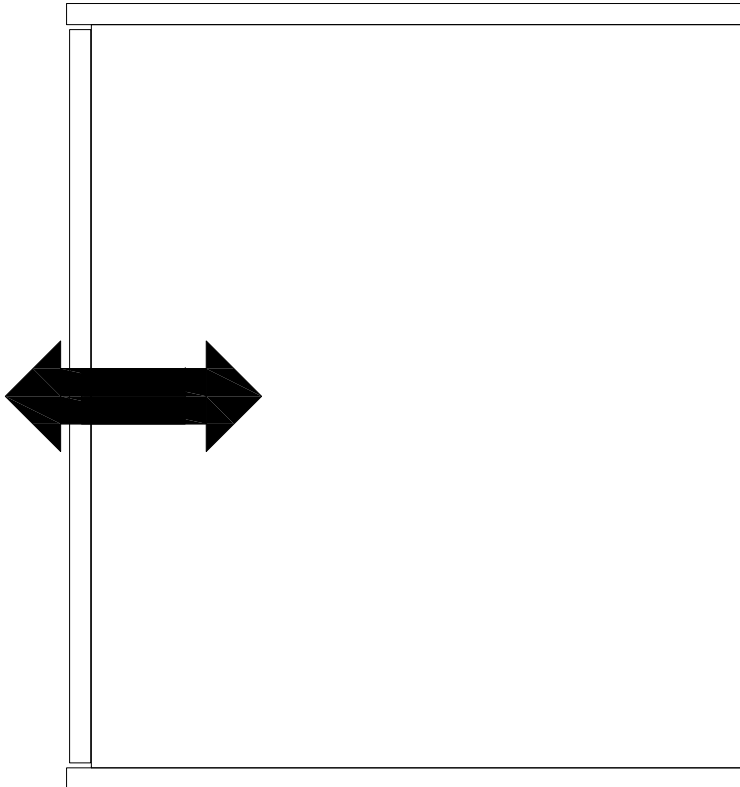

STEP 12. IF YOU NEED TO SLIDE THE DOOR FORWARD OR BACKWARD, PLEASE FOLLOW THIS STEP.

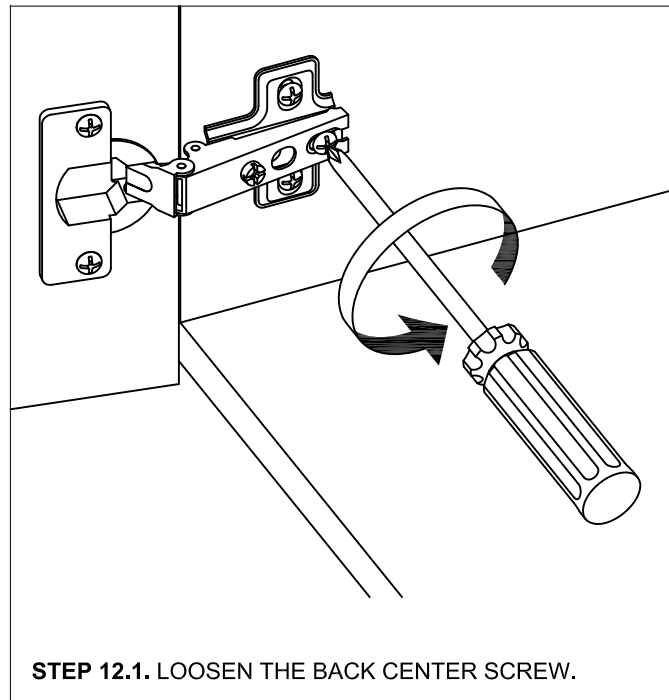

STEP 12.1. LOOSEN THE BACK CENTER SCREW.

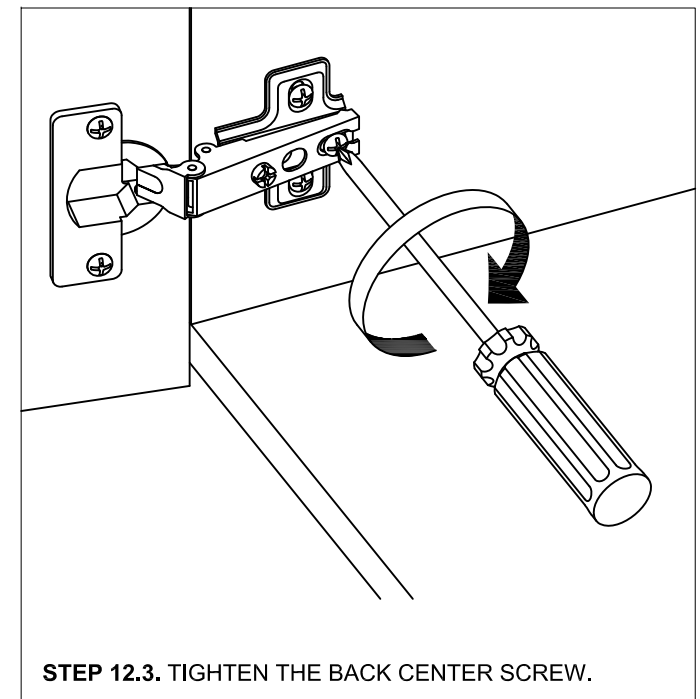
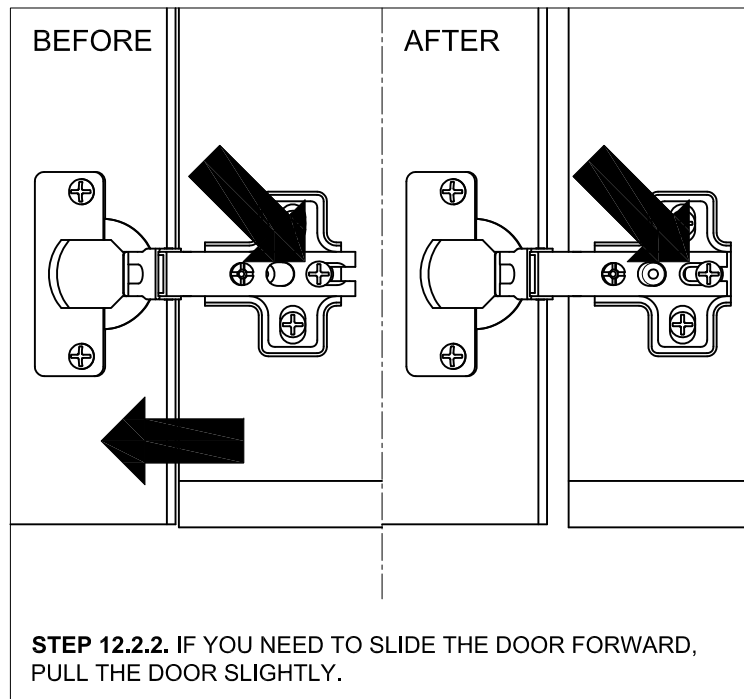
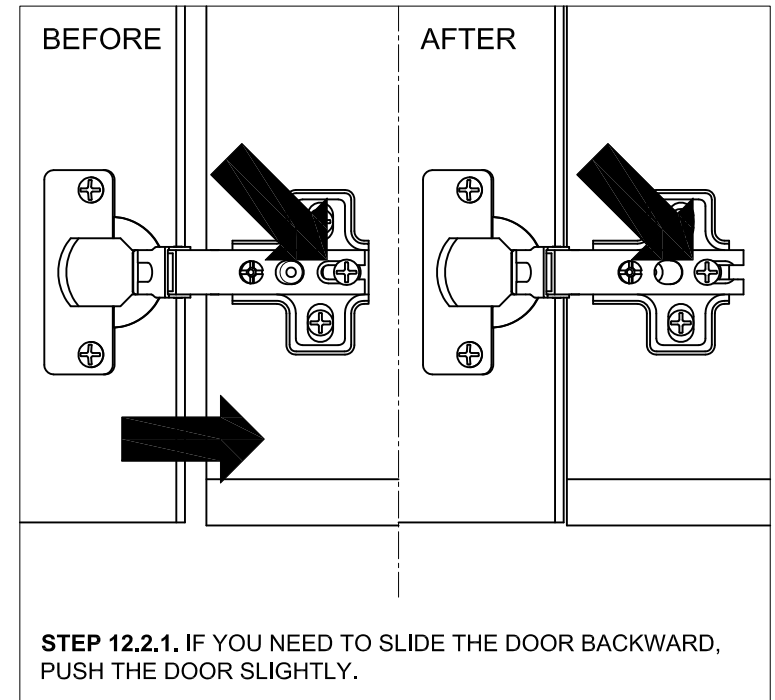

STEP 12.3. TIGHTEN THE BACK CENTER SCREW.

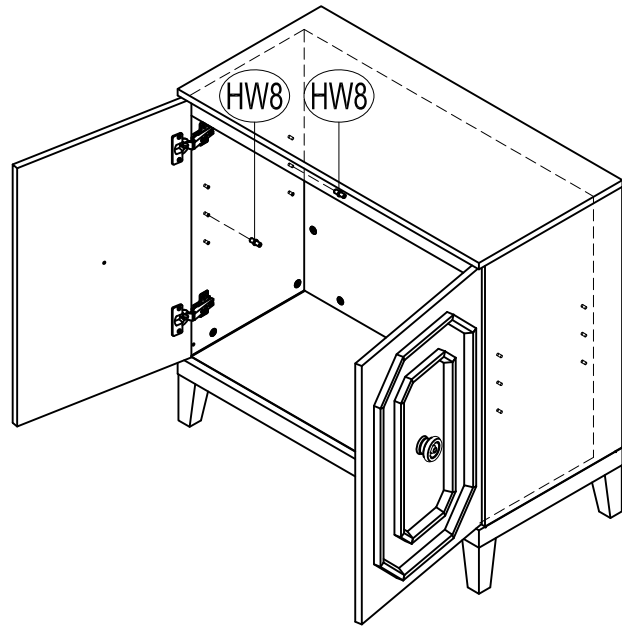

STEP 13.1. INSERT SHELF PINS INTO LEFT SIDE OF UNIT AT DESIRED LEVEL.

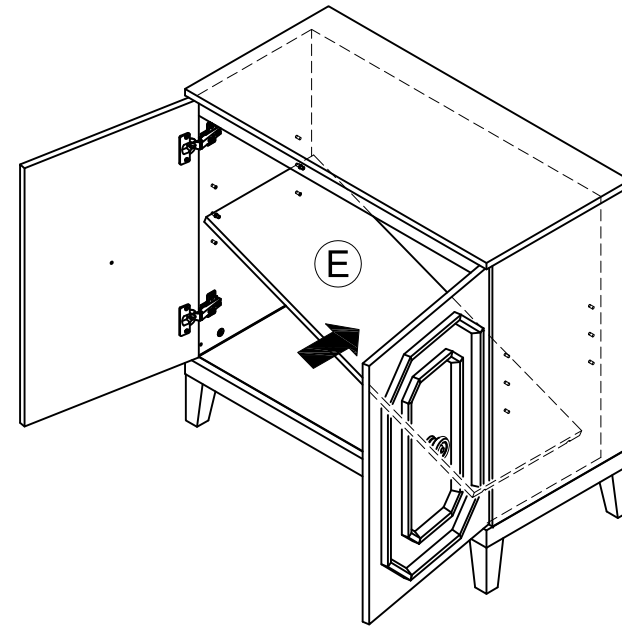

STEP 13.2. PLACE THE LEFT SIDE OF THE ADJUSTABLE SHELF INTO POSITION.

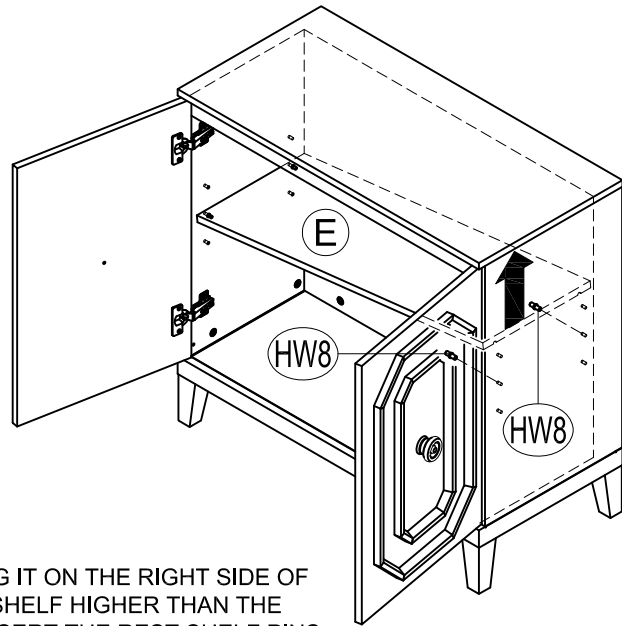

STEP 13.3. HOLDING IT ON THE RIGHT SIDE OF THE ADJUSTABLE SHELF HIGHER THAN THE DESIRED LEVEL, INSERT THE REST SHELF PINS INTO RIGHT SIDE OF UNIT AT DESIRED LEVEL.

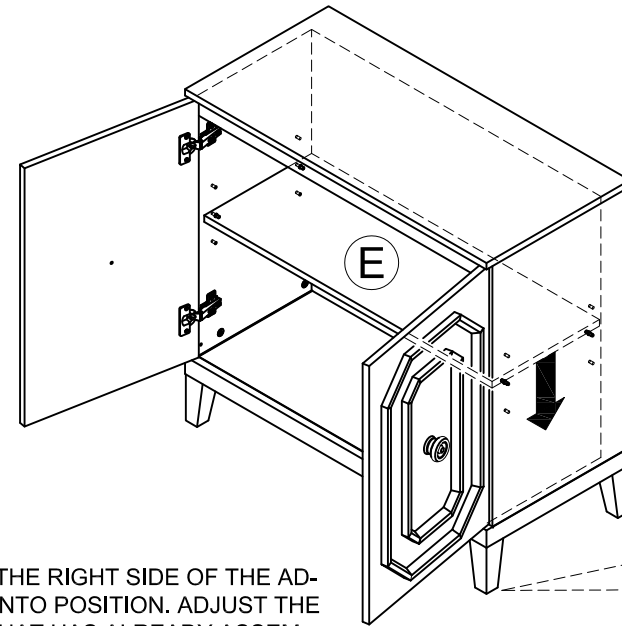

STEP 13.4. PLACE THE RIGHT SIDE OF THE ADJUSTABLE SHELF INTO POSITION. ADJUST THE ADJUSTER BOLT THAT HAS ALREADY ASSEMBLED TO THE LEGS TO STABILIZE YOUR UNIT