

**33" DAMITA DOUBLE
BOWL FARMER SINK**

Cat. No
FSSDB2510-SS



W: 33"
D: 20-3/4"
H: 10"

***Please do NOT cut hole without
template or actual product.**

Interior Dimensions:

Large

Basin Interior: 17-1/2" W x 16" D
Basin Depth: 9"

Small

Basin Interior: 11-1/2" W x 16" D
Basin Depth: 9"

Features:

- ▶ Solid 16 gauge, 304 grade metal construction
- ▶ Tight radius corners
- ▶ Easy maintenance with matte finish
- ▶ Insulated for sound reduction
- ▶ Curved bowl
- ▶ Rim width is 1-1/2"
- ▶ Drain is 3-1/2"
- ▶ 60/40 offset
- ▶ Wire grid available to purchase separately,
FSSDB2510-Wire

Compliance Certification
Meets or exceeds the following
specifications: ASME
A112.19.3-2001 for Stainless Steel.

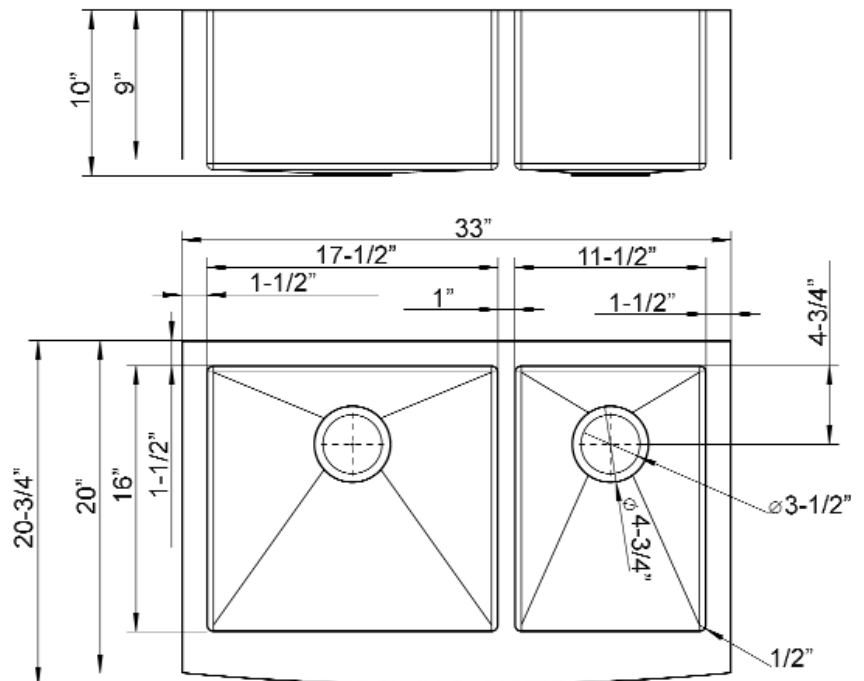

Dimensions of fixture are nominal and may vary within the range of tolerances established by ANSI Standard A112.19.2. Dimensions and specifications subject to change without notice.