

Rangaire

RANGAIRE SPEC SHEET TEMPLATES

2024



Our 24 Inch Professional Electric Range - the perfect kitchen companion for your culinary adventures. With our innovative PerfectCook™ Timer, your dishes will always be cooked to perfection. The Radiant-Glow™ Infrared Burners heat up quickly and efficiently, allowing for fast and precise cooking results. Our AireCook™ Convection mode eliminates hot and cold spots, ensuring consistent and even cooking results. With our EasyReach Rack™, you can safely and easily access dishes at the back of the oven. The sleek and smooth glass surface of our electric range is easy to clean and maintain, while its modern design adds a touch of elegance to any kitchen. Plus, our glass cooktops are compatible with any cookware, scratch-resistant, and built to last for years to come. With our Chef's Nook™ Storage Drawer, you can keep your kitchen essentials organized and accessible. Elevate your cooking experience with the Rangaire 24" Electric Range.

TECHNICAL DETAILS

Fuel Type	Electric
Electrical Requirements	240V
Circuit Breaker (A)	15 A
Frequency (Hz)	60 Hz
Product:	24 Inch Electric Range
Model:	RRE241TS
WARRANTY:	1 Year Limited Parts and Labor Warranty



FEATURES & BENEFITS

- + **PerfectCook™ Timer** - The PerfectCook™ Timer ensures precise cooking results by automatically shutting off the oven when the set time is reached, resulting in perfectly cooked meals every time.
- + **RadiantGlow™ Infrared Burners** - Experience fast and efficient cooking results with our electric infrared burners, while enjoying easy cleaning and a sleek design that enhances the look of your kitchen.
- + **TrueAire™ Convection Oven** - Achieve perfectly cooked dishes with crispy crusts and juicy centers every time, thanks to our advanced TrueAire™ Convection Oven with dedicated fan and element that evenly distribute hot air, cook food quickly and evenly, and save energy for more enjoyable meals.
- + **EasyReach Rack™** - Easily access dishes at the back of the oven with our convenient telescopic oven racks, ensuring safer and more convenient food handling.
- + **Smooth Glass Surface** - Our electric ranges feature a smooth and easy-to-clean ceramic glass surface, allowing you to spend less time cleaning and more time cooking delicious meals.
- + **Sleek Design** - Enhance your kitchen with the sleek and modern design of our electric range, adding an elegant touch to your cooking space.
- + **Even Heat Distribution** - Enjoy consistent and precise cooking results every time with our electric cooktops' even heat distribution, eliminating hot spots and cold spots.
- + **Cookware Compatible** - Our glass cooktops are designed to be compatible with all types of cookware, providing versatility and flexibility in your cooking.
- + **Scratch Resistant Glass** - Built to withstand everyday use, our high-quality, scratch-resistant glass cooktops maintain their pristine appearance for years to come.
- + **Chef's Nook™ Storage Drawer** - Keep your kitchen essentials organized and within reach with our convenient storage drawer, ensuring a clutter-free cooking environment.
- + **CSA Certification** - Cook with confidence and peace of mind knowing that our CSA-certified range has met rigorous safety standards, ensuring a secure and worry-free cooking experience for you and your family.
- + **Designed in California by Rangaire®** - Experience the legacy of Rangaire® with our meticulously designed kitchen appliances, crafted to the highest standards of quality, functionality, and style.
- + **1 Year Limited Parts and Labor Warranty** - Trust in the reliability of our Rangaire® products, backed by a 1-year warranty ensuring exceptional customer service and support in the rare event of any issues.

PRODUCT DIMENSIONS			
Product Width	23.62	Product Depth (from back panel to control board)	25
Height (to top of side panel)	36.06	Product Depth (with handle)	27
Height (to top of rear vent)	37.83	Product Depth (Oven door fully Open)	42.32

DETAIL			
Total Burners	4	Hot Surface Indicator Light	Yes
[1]Left Front Element	3000W	Drawer Type	Lower Storage Drawer
[2]Left Rear Element	1200W	Convection	True Convection
[3]Right Front Element	1800W	Oven Light	1
[4]Right Rear Element	1200W	Total Elements	4
Oven Capacity (cu. ft.)	3	Standard Rack	2
Cooktop Surface	Glass Ceramic	Telescopic Rack	1
Oven Color	Dark Gray Porcelain	Rack Positions	6
Color	Stainless Steel	Cleaning Type	Manual Clean
Controls Type	Manual	Product Weight (lb.)	125.7

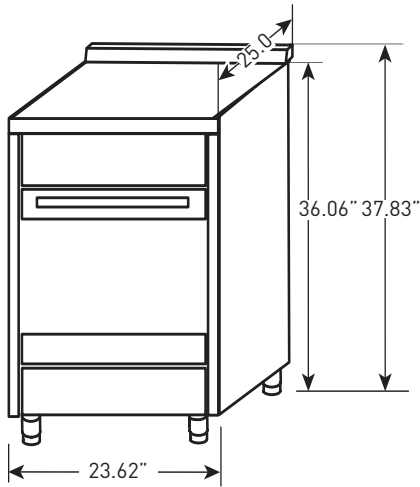

Product width	23.62in
Height (to top of side panel)	36.06in
Height (to top of rear vent)	37.83in
Product Depth	25.0in
Product Depth (with handle)	27.0in
Product Depth (Oven door fully open)	42.32in