



**FR Remerciements :**

**IT Ringraziamenti:**

**RO Mulțumiri:**

**EN Thanks:**

**NL Bedankje:**

**RU Благодарность:**

**DE Danksagung:**

**CZ Poděkování:**

**SK Pod'akovanie:**

**ES Agradecimientos:**

**HU Köszönet:**

**TR Teşekkür ederiz:**

**PT Agradecimentos:**

**PL Podziękowania:**

**AR :**

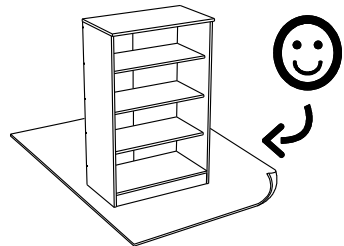
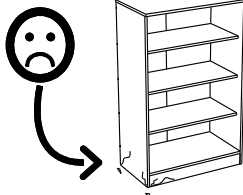
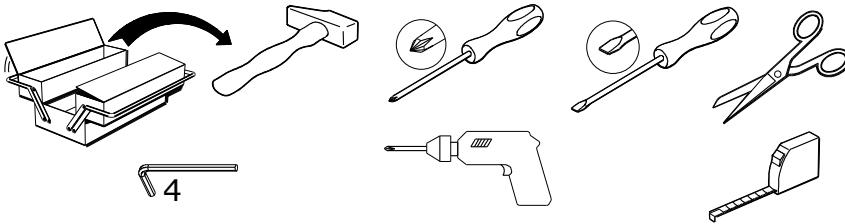

150.5cm  
59 1/4"  
66cm  
26"  
41cm  
16 1/4"

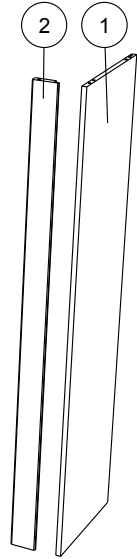
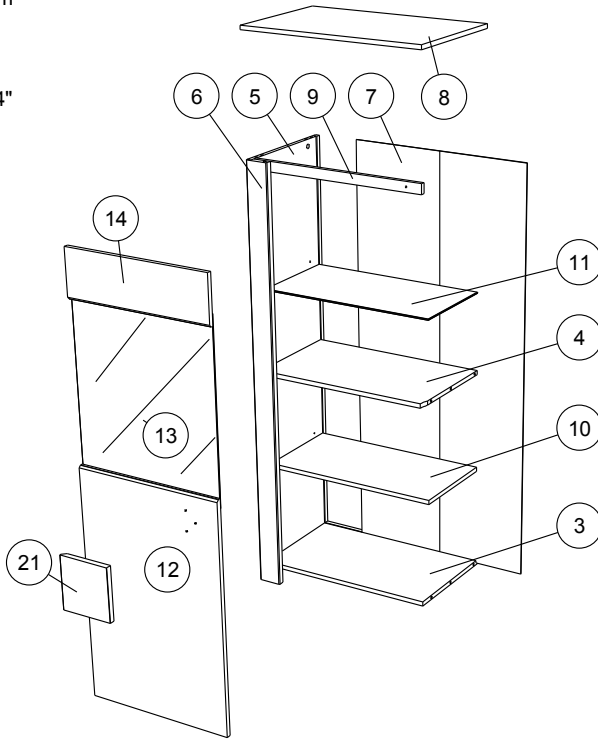

		mm			inch		
21	x 1	160	156	16	6 5/16	6 1/8	5/8
14	x 1	491	155	15	19 5/16	6 1/8	9/16
9	x 1	624	35	16	24 9/16	1 3/8	5/8
10	x 1	624	321	15	24 9/16	12 5/8	9/16
4	x 1	624	362	15	24 9/16	14 1/4	9/16
3	x 1	624	382	15	24 9/16	15 1/16	9/16
8	x 1	658	408	15	25 7/8	16 1/16	9/16
12	x 1	752	491	15	29 5/8	19 5/16	9/16
2	x 1	1487	80	22	58 9/16	3 1/8	7/8
6	x 1	1487	80	22	58 9/16	3 1/8	7/8
1	x 1	1487	398	15	58 9/16	15 11/16	9/16
5	x 1	1487	398	15	58 9/16	15 11/16	9/16
13	x 1	572	489	4	22 1/2	19 1/4	3/16
11	x 1	623	321	5	24 1/2	12 5/8	3/16
7	x 1	1438	640	3	56 5/8	25 3/16	1/8



Ai x 14



QP x 3

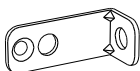

BLL x 6

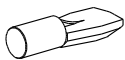

BWD x 4



RT x 6



EP x 2



HV x 1



AOP x 2

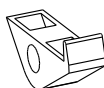

NT x 2

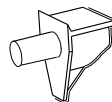

DJ x 2

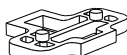

ANN x 3



CCS x 3

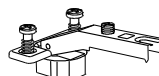

CCR x 3

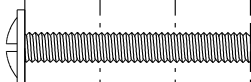
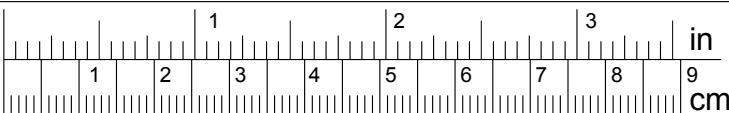

YM x 3

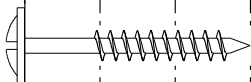

WH x 2



ADM x 18

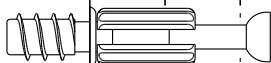

BSD x 14

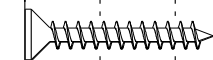

VJ x 2

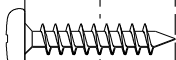

AGN x 6

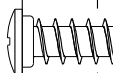

VB x 10

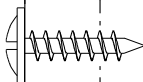

AMO x 6



BVS x 3

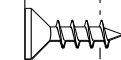

VG x 4



ANK x 6

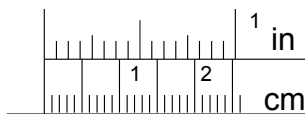

1

BSD x 5

BLL x 2

Ai x 3

VB x 2

ADM x 5

VB

BLL

2

ADM

ADM

ADM



BSD

BSD

1

ADM

2

1

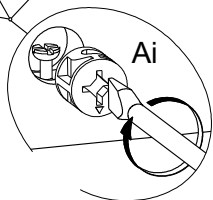

2



ADM x 8

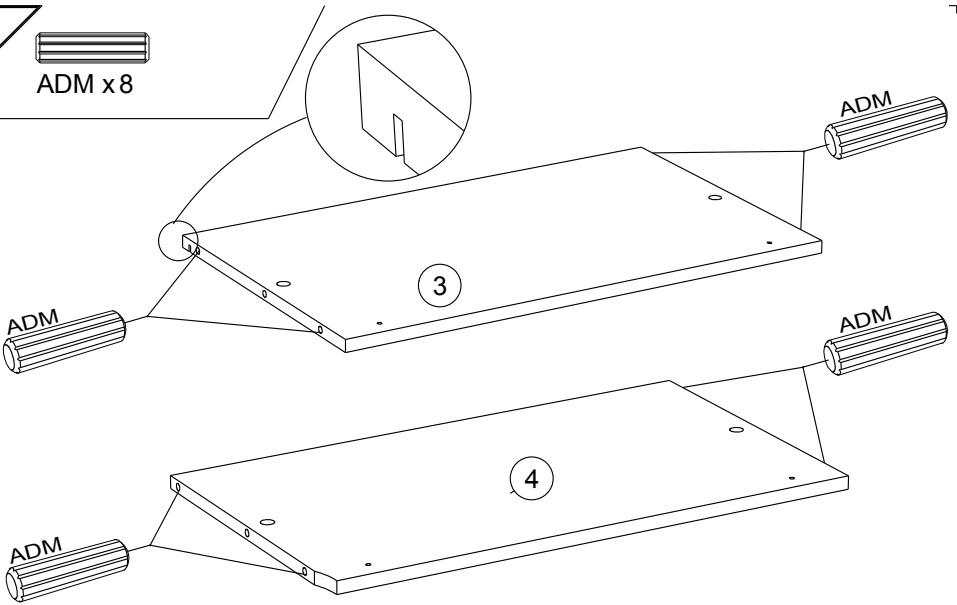

3



Ai x 2



VB x 2

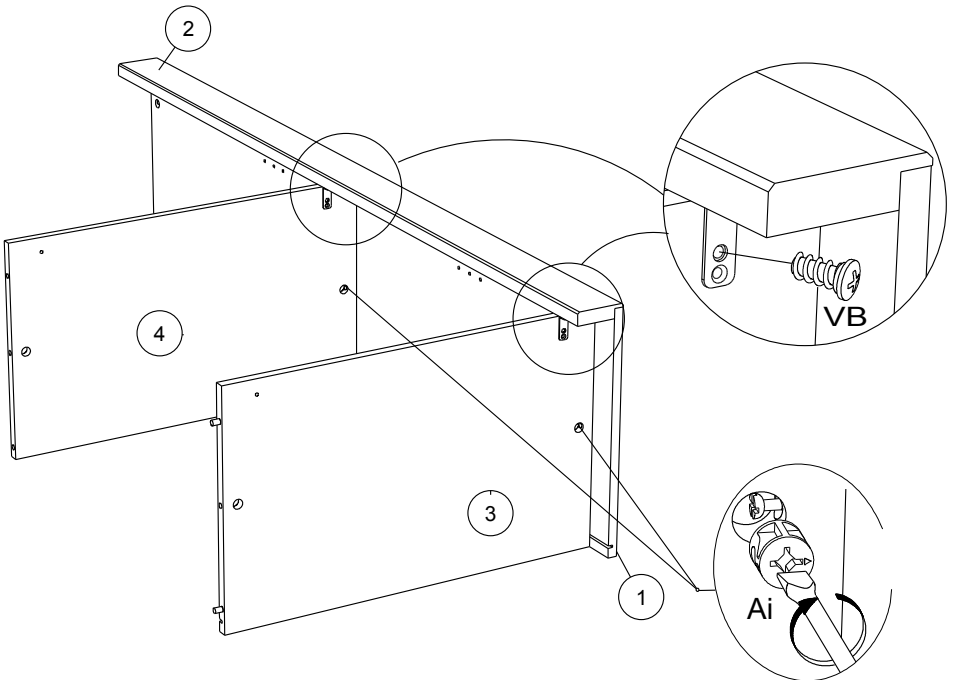

4

BSD x 5

ADM x 5

Ai x 3

CCS x 3

ANN x 3

AGN x 6

VB x 2

BLL x 2

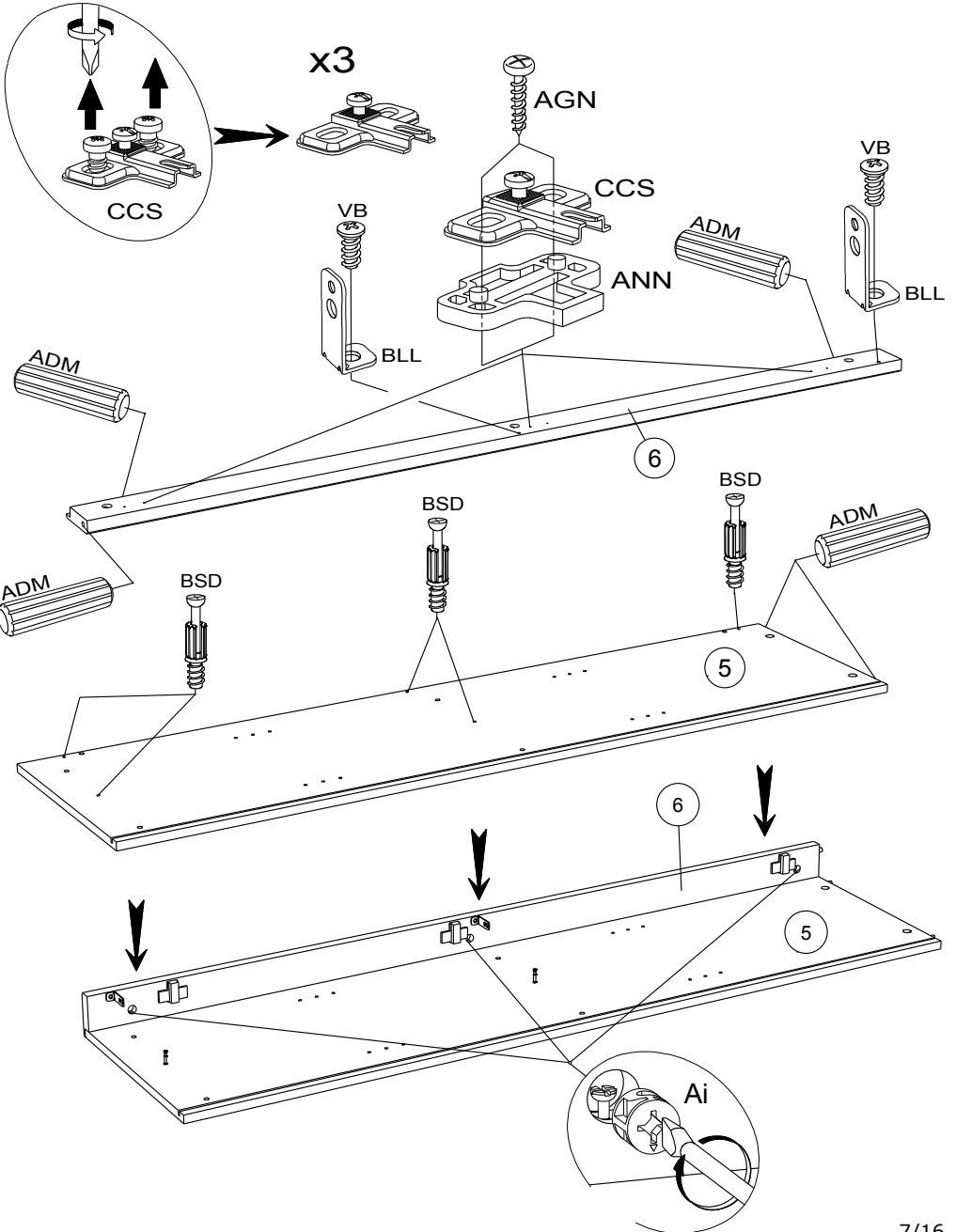

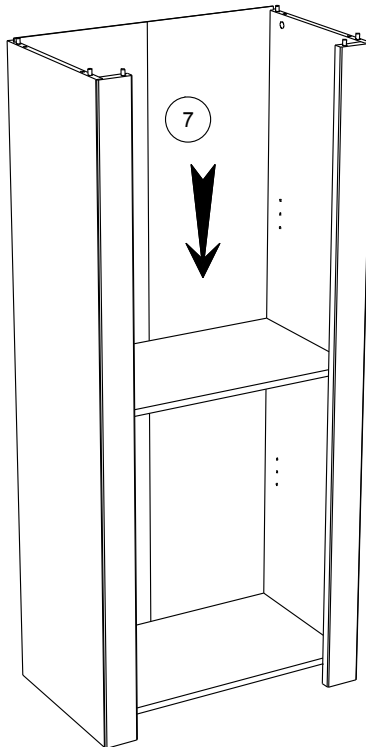
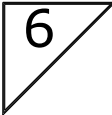
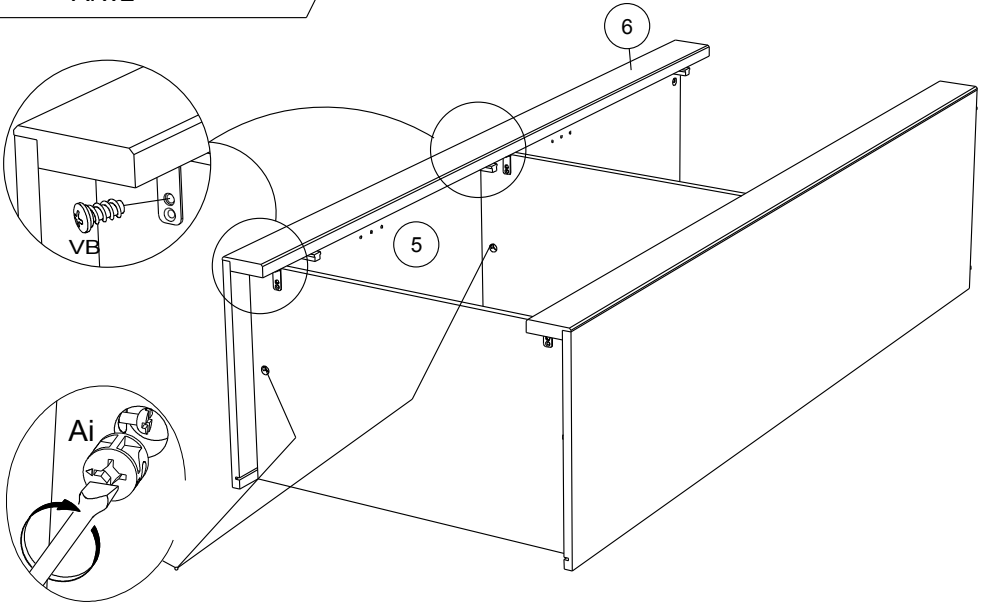
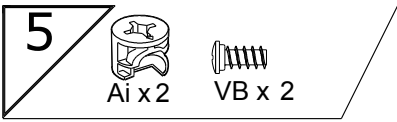

7

BSD x 4

VG x 1

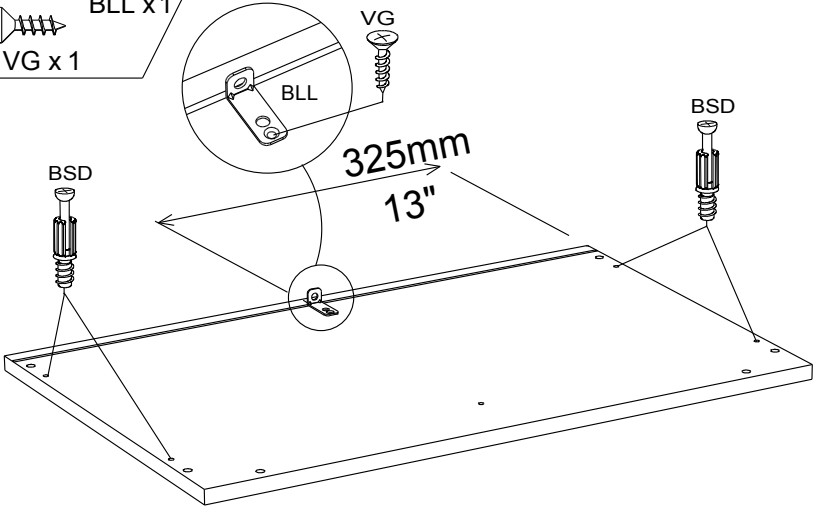
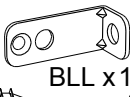

8

Ai x 4

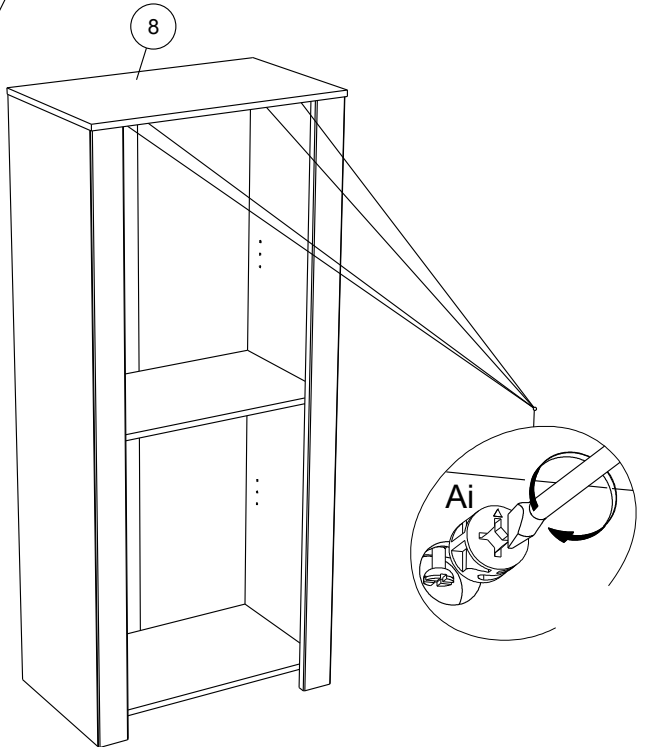

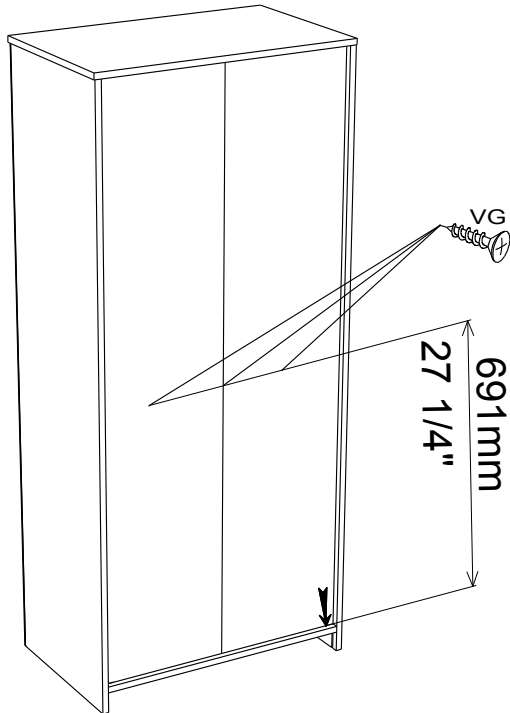
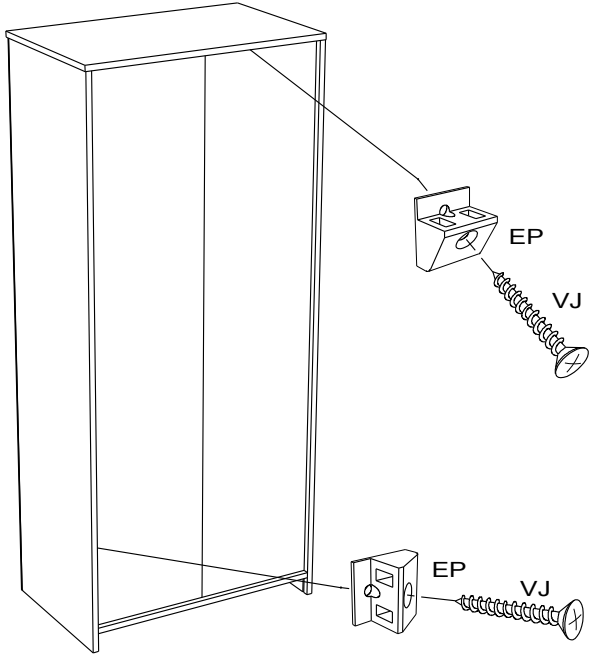
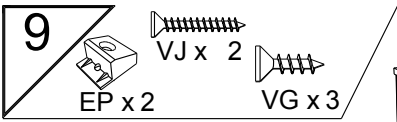

- FR** Pour votre sécurité : Fixation du meuble au mur  
Attention, la fixation doit être réalisée par une personne compétente car cela nécessite des chevilles adaptées à la nature de votre mur.
- EN** For your safety: the unit should be secured to the wall.  
NB this should be carried out by a competent person as you must use the right rawlplug for your type of wall.
- DE** Zu Ihrer Sicherheit: Befestigen Sie das Hochbett an der Wand.  
Achtung: Diese Befestigung ist durch eine fachlich kompetente Person vorzunehmen. Hierfür sind für die Bauweise Ihrer Wand geeignete Dübel einzusetzen.
- ES** Por su seguridad: Fijar el mueble a la pared.  
Advertencia: la fijación la ha de llevar a cabo por personal adecuado, ya que requiere el uso de tacos que se adaptan al tipo de pared.
- PT** Para sua segurança: fixação do móvel ao muro  
Atenção: a fixação deverá ser efetuada por pessoa habilitada, visto que são necessárias cavilhas adaptadas ao tipo de parede.
- IT** Avvertenza di sicurezza: il fissaggio del mobile a parete deve essere realizzato da una persona competente, in quanto l'operazione richiede l'impiego di tasselli adatti alla natura del muro.
- NL** Voor uw veiligheid: bevestiging van het meubel aan de muur.  
Opgelet de bevestiging moet worden uitgevoerd door een bekwam persoon daar dit voor uw type muur geschikte pluggen vereist.
- CZ** Z bezpečnostních důvodů: upevněte nábytek do zdi  
Pozor, upevnění je třeba svěřit kompetentní osobě, neboť vyžaduje hmoždinky vhodné pro vaši zed'.
- HU** Az Ön biztonságá érdekében : a bútor falra rögzítése  
Figyelmeztetés : a rögzítés csak megfelelő szakképesítéssel rendelkező személy által végezhető el, mert a rögzítéshez a falnak megfelelő csavarokra van szükség.
- PL** Dla bezpieczeństwa: mocowanie mebla do ściany  
Uwaga, mocowanie musi zostać wykonane przez osobę kompetentną, ponieważ wymaga to zastosowania kółków dostosowanych do rodzaju ściany.
- RO** Pentru securitatea dumneavoastră: fixarea mobilierului de perete  
Atenție, fixarea trebuie să fie realizată de o persoană calificată, deoarece sunt necesare dispozitive de fixare adaptate caracteristicilor peretelui dumneavoastră
- RU** Для вашей безопасности: Крепление мебели к стене  
Внимание! Крепление должно производиться опытным специалистом, т.к. для такой установки потребуются штифты, соответствующие типу вашей стены.
- SK** Z bezpečnostných dôvodov: nábytok upevnite k stene.  
Dbajte na to, aby upevnenie vykonala kompetentná osoba, pretože pri upevňovaní sa vyžadujú kolíky vhodné do materiálu, z ktorého je stena vyrobená.
- TR** Güvenliğiniz için: Mobilyanın duvara sabitlemesi  
Dikkat, sabitleme işlemi uzman biri tarafından yapılmalıdır çünkü bu işlem için duvarınızın malzemesine uygun dübellerin kullanılması gerekmektedir
- GR** Για την ασφάλειά σας : στερέωση των επίπλων στον τοίχο.  
Προσοχή, η στερέωση πρέπει να γίνεται από ικανό άτομο, καθώς απαιτούνται σφηνές προσαρμοσμένες στη φύση του τοίχου σας.

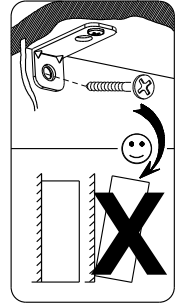
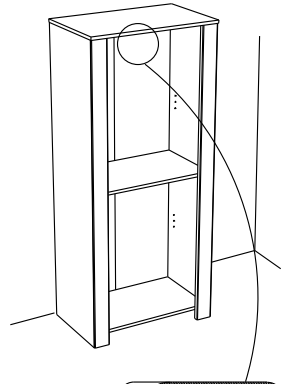

### اللغة العربية

لسلامتك الشخصية: تثبيت قطعة الأثاث على الحائط  
تحذير، يجب أن يقوم شخص متخصص بعملية التثبيت على الحائط إذ أنها تتطلب اسفينا  
معينا يتوافق مع طبيعة الحائط نفسه.

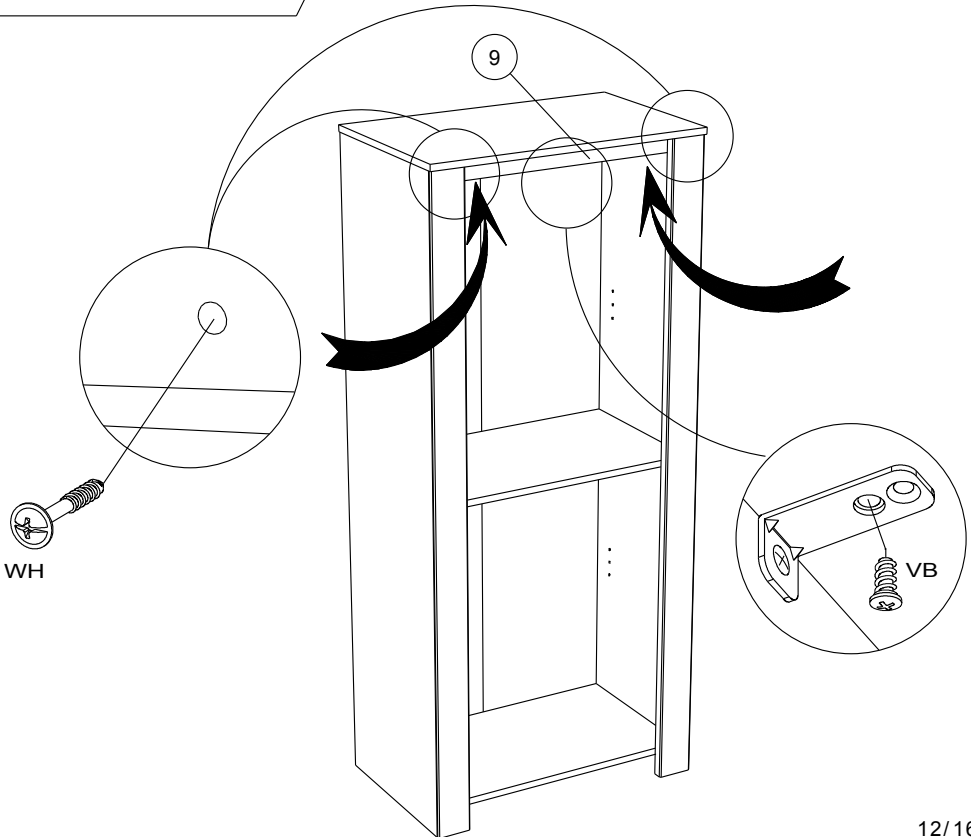
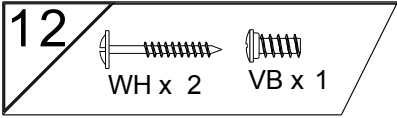
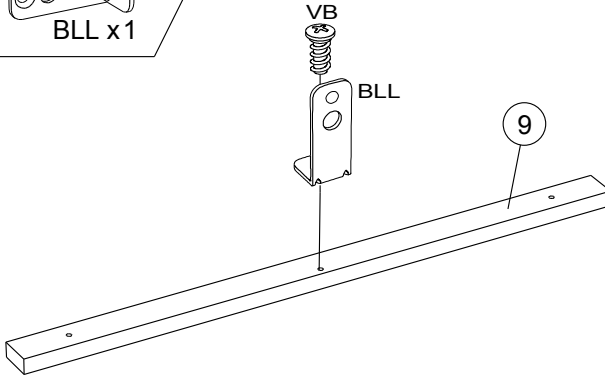
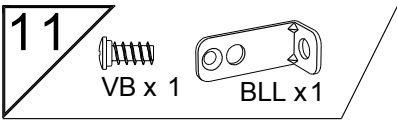

13

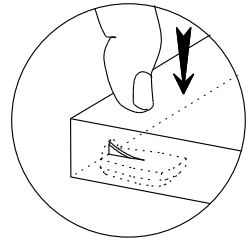
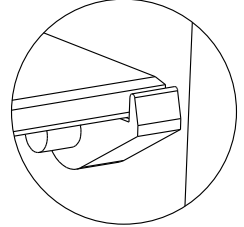
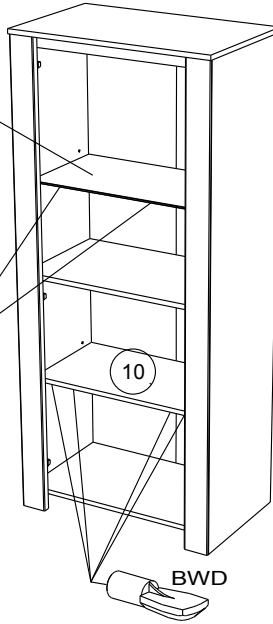
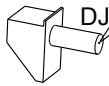
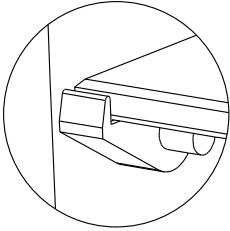
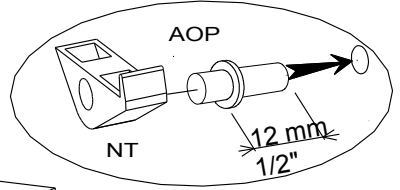
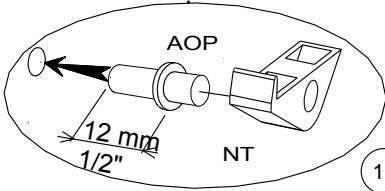
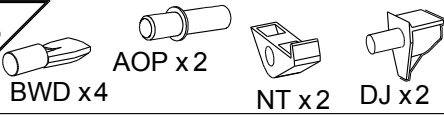

14

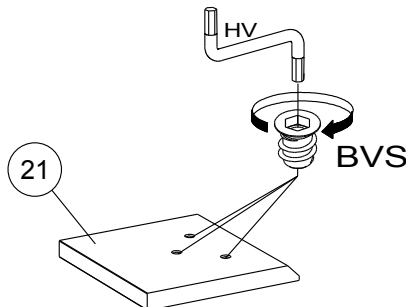
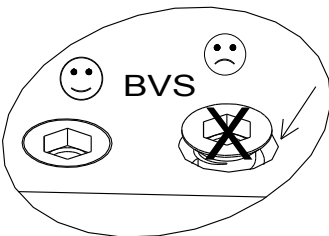

15



ANK x 6



RT x 6



AMO x 6

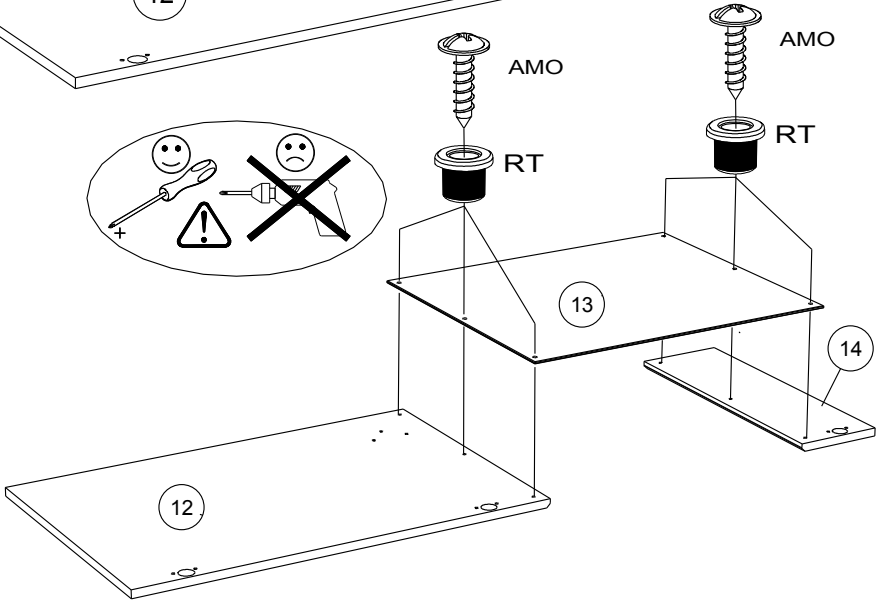
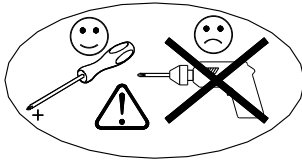
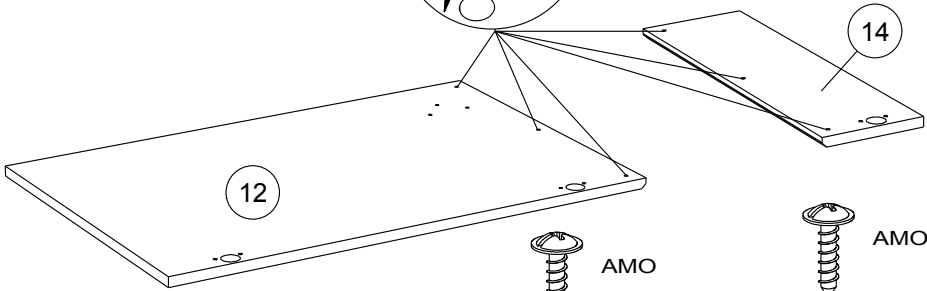
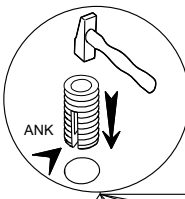

16



CCR x 3

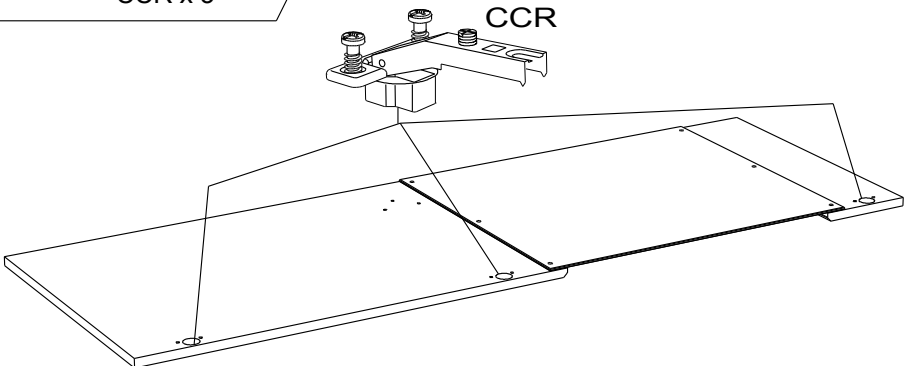

17

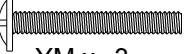

YM x 3



QP x 3

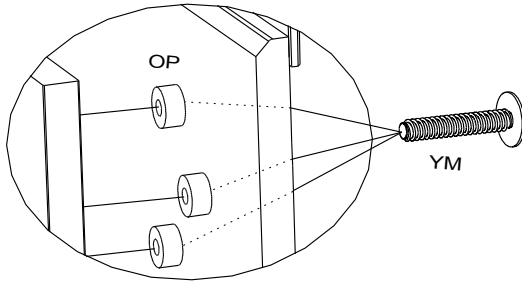
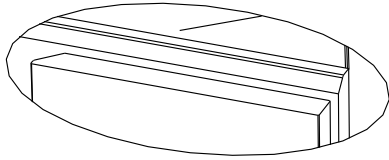

21

YM

RCH-C-N

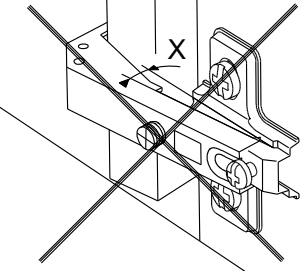

MONTAGE

- (GB) LEAFLET
- (D) AUFBAUANLEITUNG
- (E) MONTAJE
- (P) MONTAGEM
- (I) MONTAGGIO
- (NL) MONTAGE

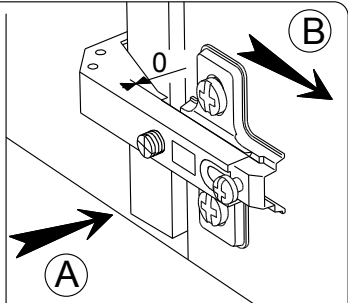

REGLAGES (GB) ADJUSTING (E) AJUSTER (I) AGGIUSTAMENTO  
(D) ANPASSUNG (P) REGULACAO (NL) AFSTELLING

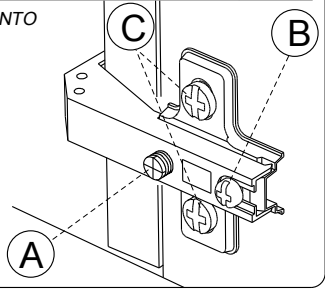
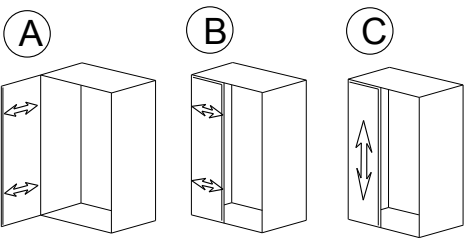

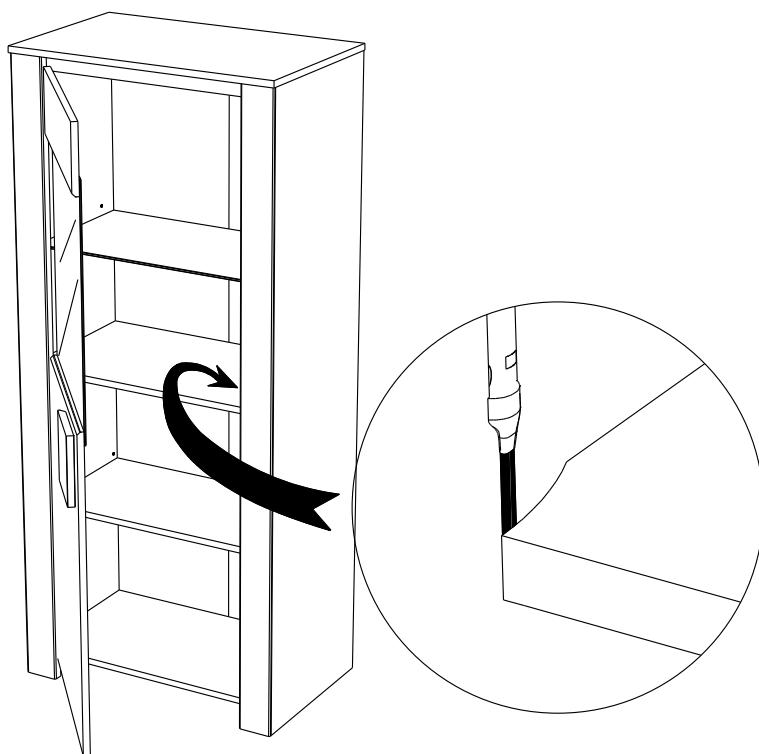

POSSIBILITE  
D'ECLAIRAGE PAR LEDS  
DISPONIBLE EN MAGASIN

