

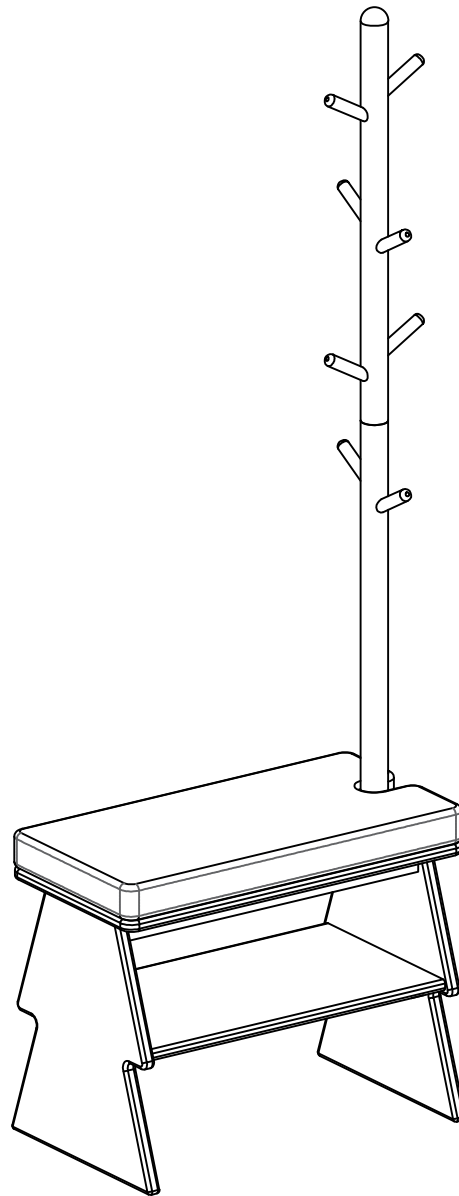

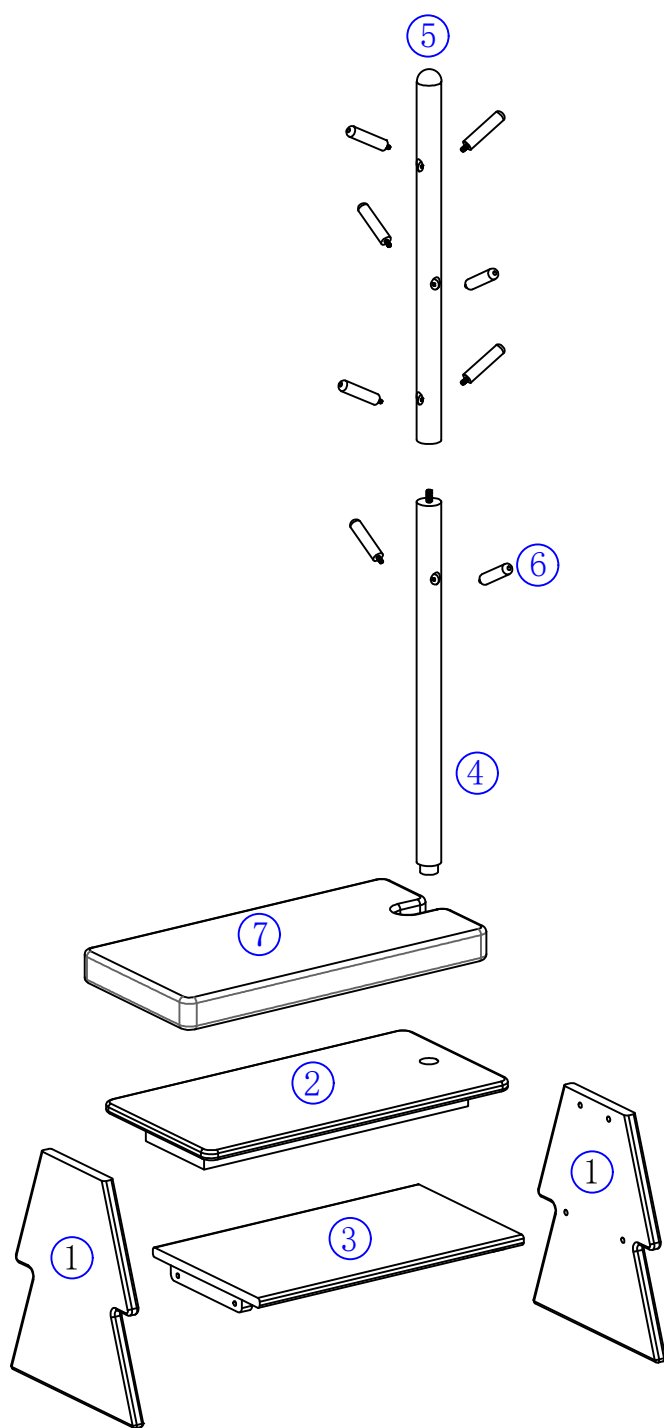

# Installation & Assembly



# Installation Diagram

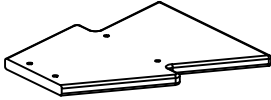

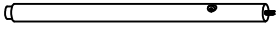
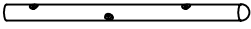
# Parts List

<p>① Side Panel</p>  <p>400*350*20MM      2PC</p>	<p>② Back Panel</p>  <p>600/800/1000*300*57MM      1PC</p>	<p>③ Shelf Panel</p>  <p>520/720/*920*21MM      1PC</p>
<p>④ Lower Section of Coat Rack</p>  <p>635* 40MM      1PC</p>	<p>⑤ Upper Section of Coat Rack</p>  <p>635* 40MM      1PC</p>	<p>⑥ Handle</p>  <p>80* 18MM      8PC</p>
<p>⑦ Cushion Pad</p>  <p>600/800/1000*300*55MM      1PC</p>		

## Note

Use the correct size screws to prevent damage to the components.

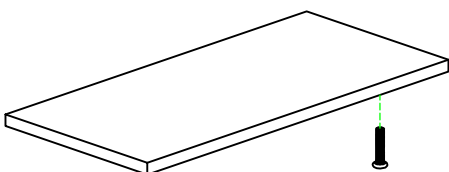

Example

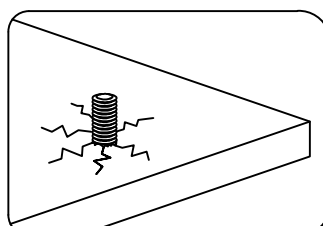



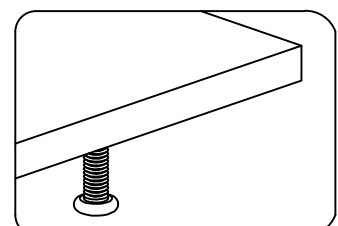

Incorrect: Oversized screws may crack the wood.



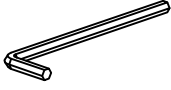

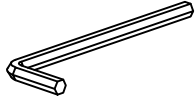

Correct: Use screws that match the pre-drilled holes.

# Hardware List

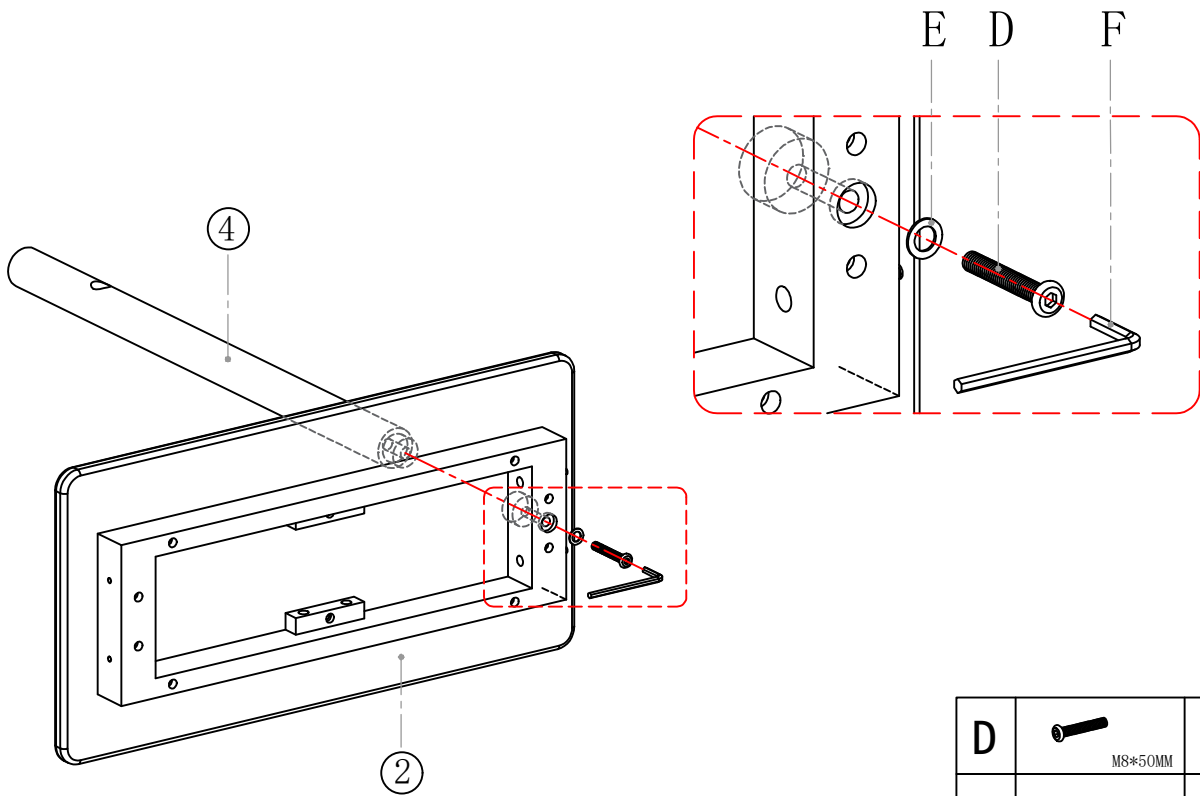
<p><b>A</b> Hex Socket Screw</p>  <p>M6*30MM <span style="float: right;">8+1 PCS</span></p>	<p><b>B</b> Hex Key Wrench</p>  <p>M4*100MM <span style="float: right;">1PC</span></p>	<p><b>C</b> Non-woven Pad</p>  <p>30*17*3MM <span style="float: right;">4+1 PCS</span></p>
<p><b>D</b> Hex Socket Screw (duplicate entry)</p>  <p>M8*50MM <span style="float: right;">1+1 PC</span></p>	<p><b>E</b> Flat Washer</p>  <p>M8*19MM <span style="float: right;">1+1 PCS</span></p>	<p><b>F</b> Hex Key Wrench (duplicate entry)</p>  <p>M5*100MM <span style="float: right;">1PC</span></p>



Step 1

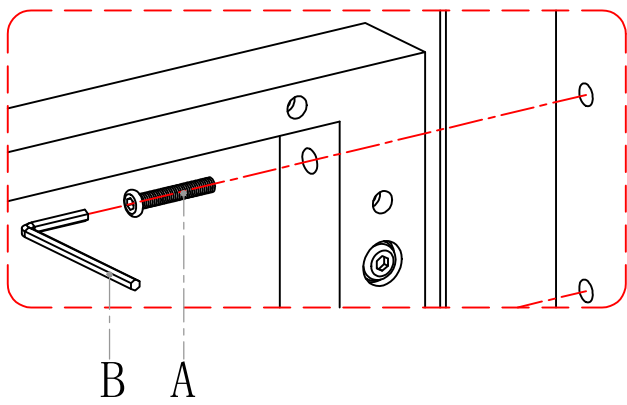
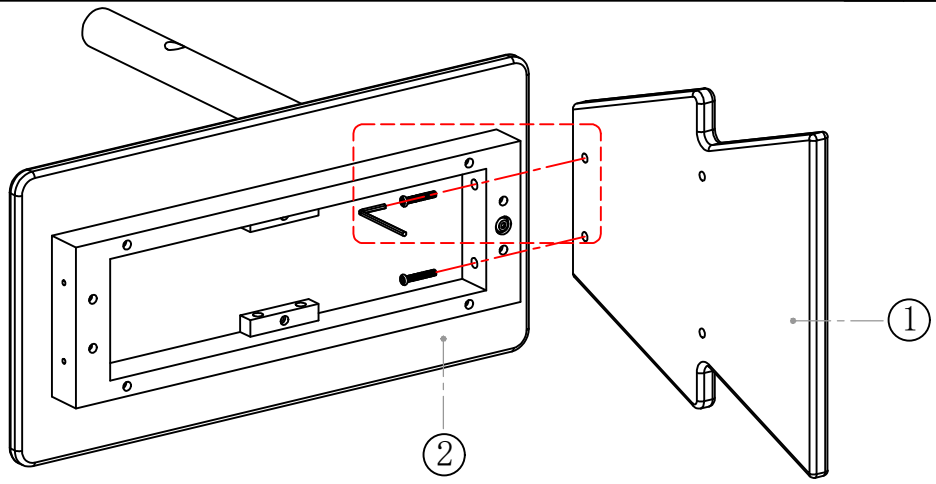

D	 M8*50MM	1 PC
E	 M8*16MM	1 PC
F	 M5*100MM	1 PC

Step 2



A	 M6*30MM	2PCS
B	 M4*100MM	1PC

Step 3

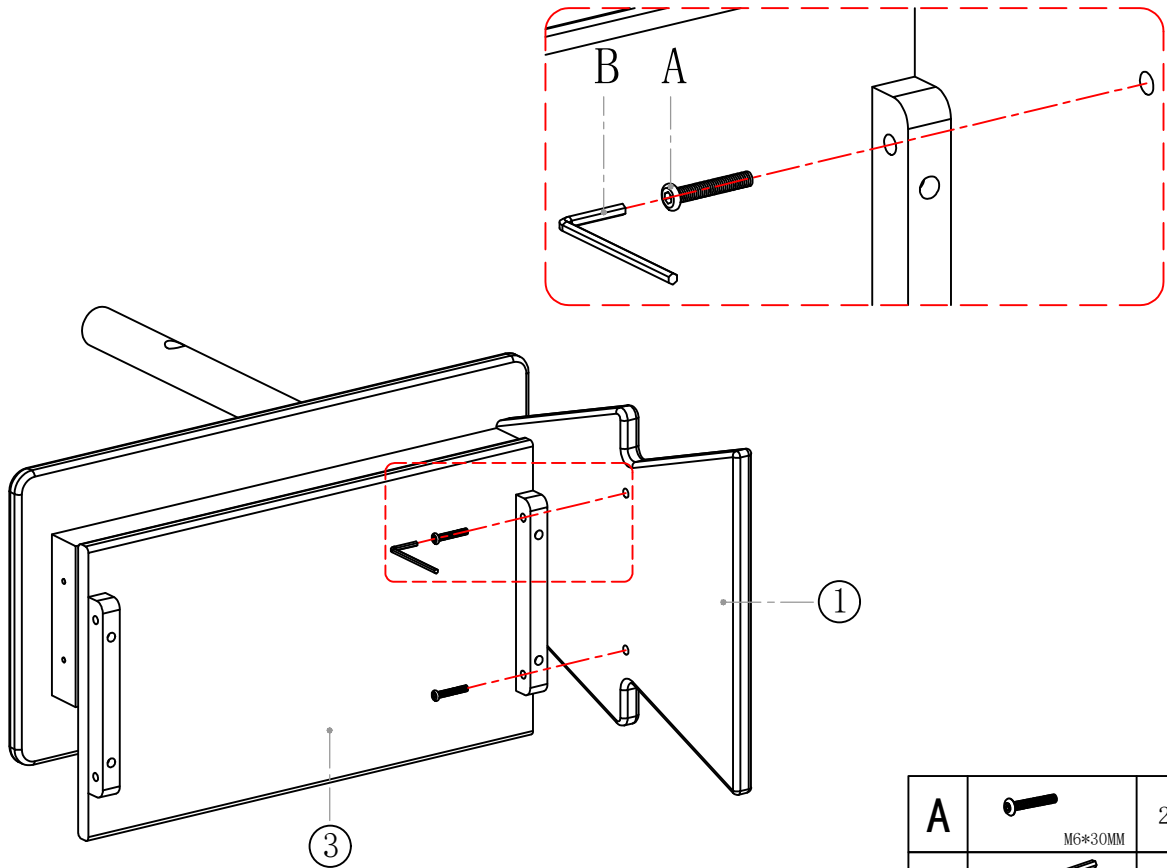

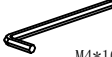
A	 M6*30MM	2PCS
B	 M4*100MM	1PC

Step 4

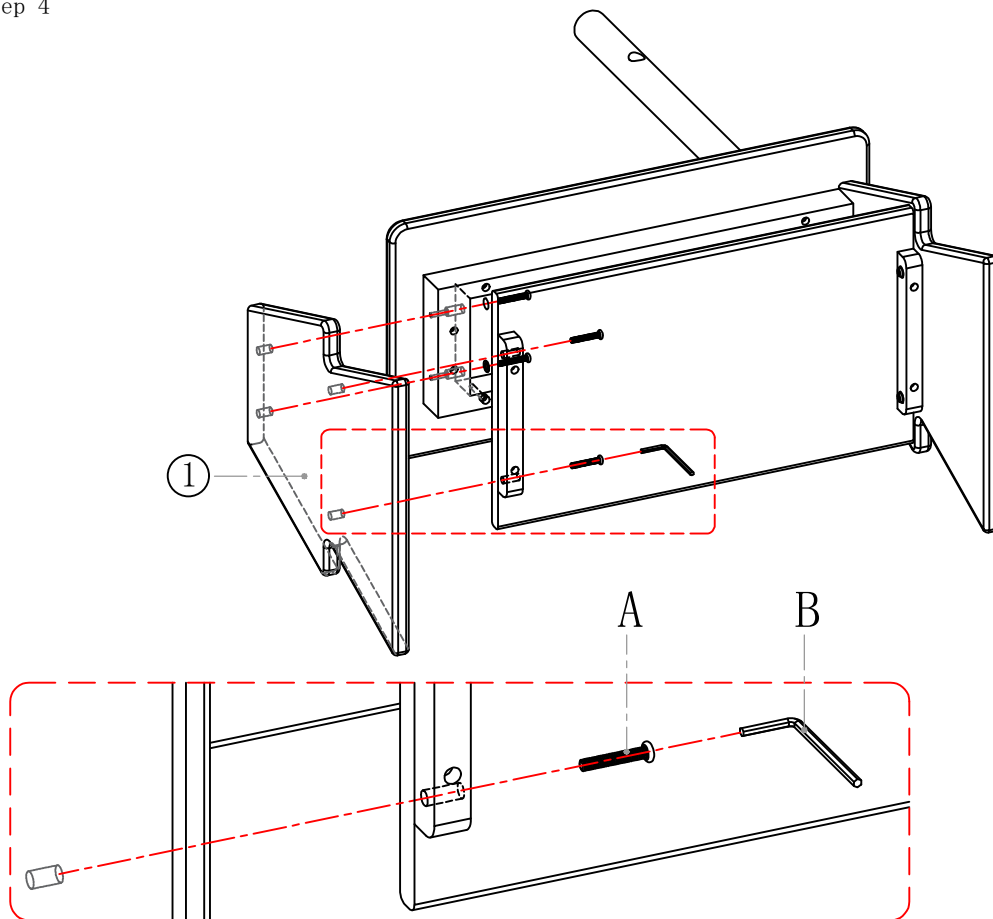

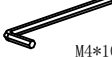
A	 M6*30MM	4PCS
B	 M4*100MM	1PC

Step 5

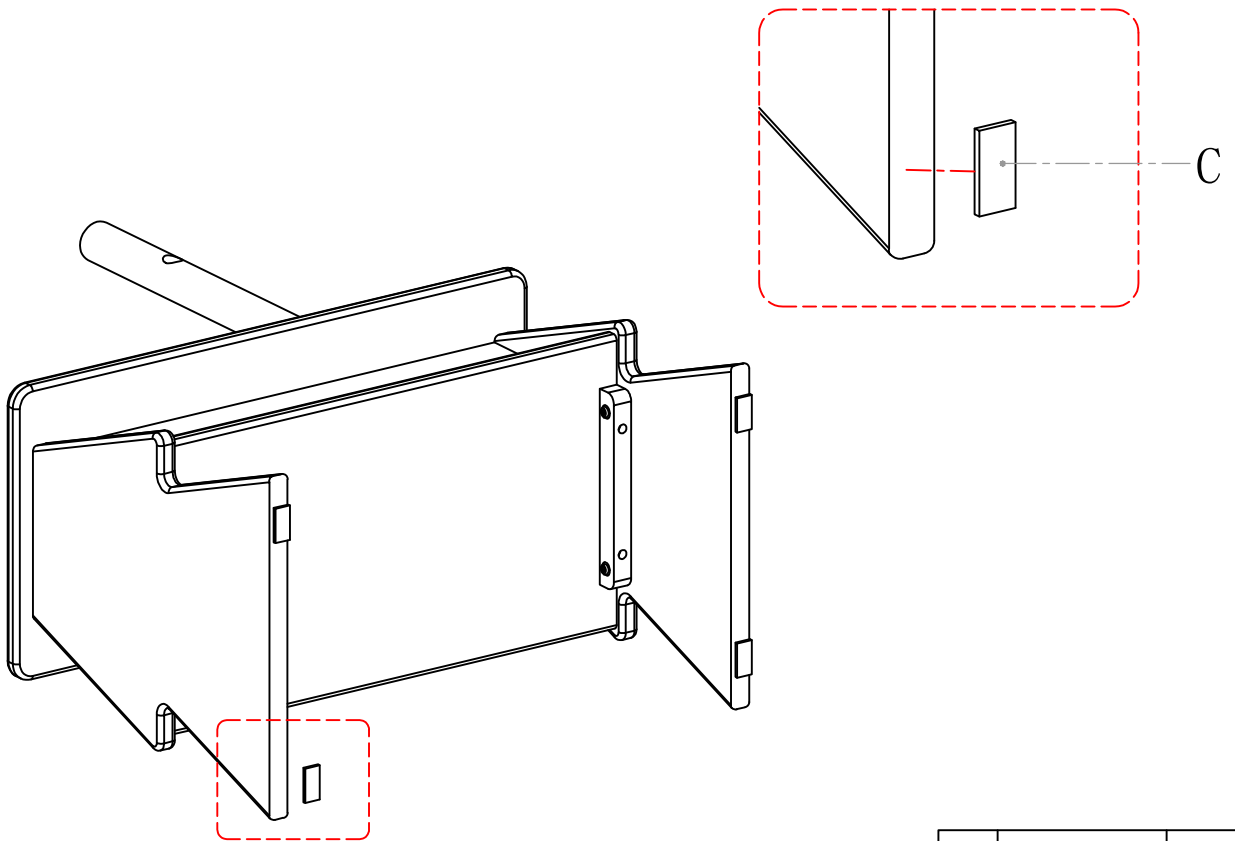

C

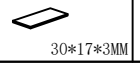

4PCS

Step 6

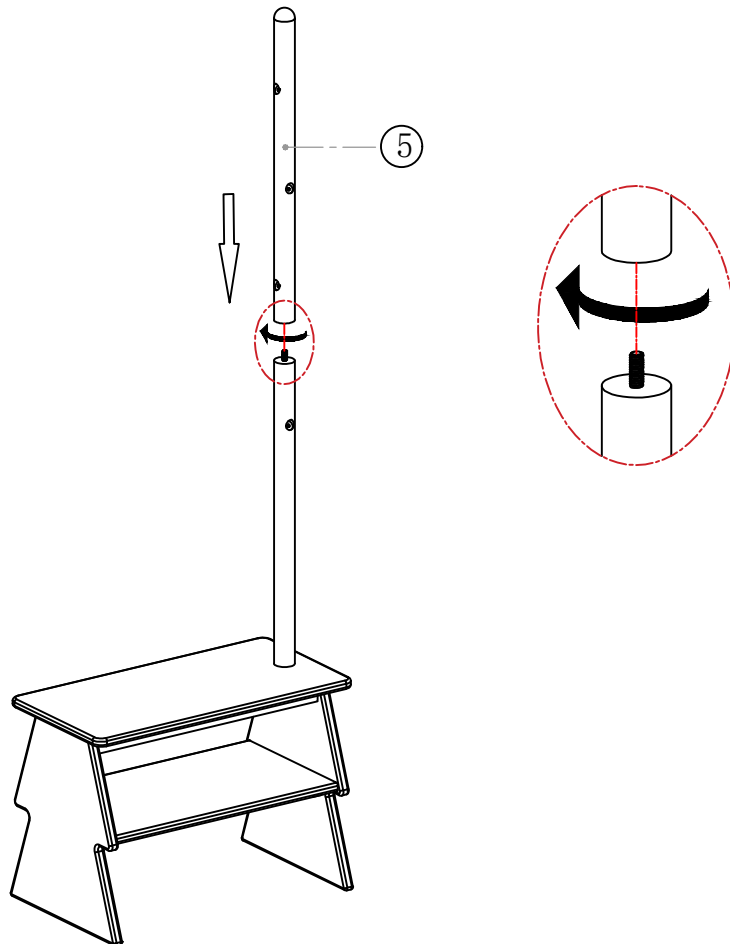

Step 7

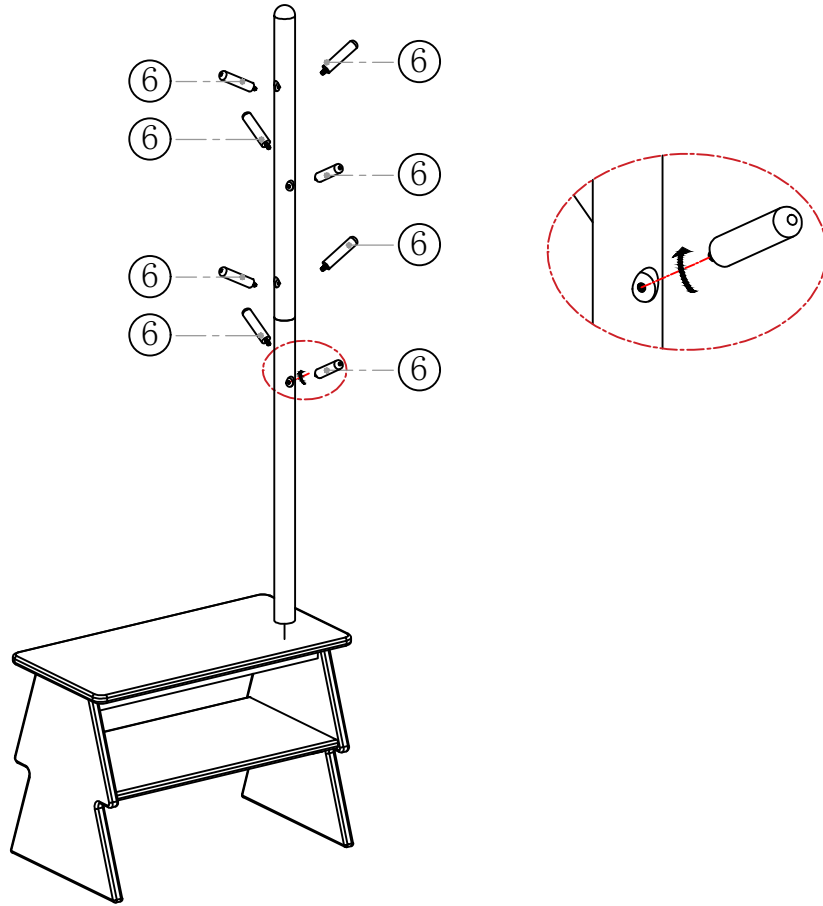

Step 8

