

# RYE BAR SET

## ASSEMBLY GUIDE

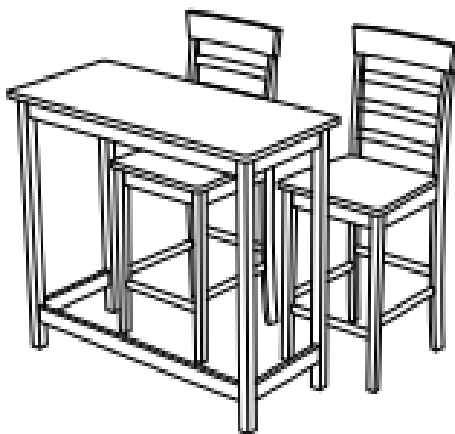

**Important - Please read these instructions fully before starting assembly**



**SAFETY AND  
CARE ADVICE**



**NO POWER TOOLS**

## **SAFETY AND CARE ADVICE**

- Check you have all the components and tools listed.
- Remove all fittings from the plastic bags and separate them into their groups.
- We do not recommend the use of power drills/drivers for inserting screws, as this could damage the unit. Only use hand screwdrivers and Allen keys.
- Keep children and animals away from the work area, small parts could cause choking if swallowed.
- Make sure you have enough space to layout the parts before starting.
- Assemble the item as close to its final position (in the same room) as possible.
- Do not overtighten the nuts to avoid causing damage to the threads.
- Only clean using a damp cloth and mild detergent, do not use bleach or abrasive cleaners.
- From time to time check that there are no loose screws on this unit
- This product should not be discarded with household waste. Take to your local authority waste disposal centre

## IMPORTANT INFORMATION



30 MINUTE  
BUILD







ONE  
PERSON



MAXIMUM  
CAPACITY  
Table 40Kg, Chair 120Kg

PLEASE CHECK CAREFULLY AND MAKE SURE YOU HAVE ALL FITTINGS AND TOOLS LISTED BELOW BEFORE YOU START.

### Bar Chair

LIST OF PARTS			LIST OF HARDWARE		
No	Description	Qty	No	Description	Qty
1	Chair Back	2	A	JCBC Bolt 	12
2	Front Leg	2	B	Spring Washer 	12
3	Apron	4	C	Wood Screw 	14
4	Chair Seat	2	D	Allen Key 	1
5	Strechter	4	E	Wood Dowel 	8

**NOTE:** The quantities above are for 2x bar chairs

### Bar Table

LIST OF PARTS			LIST OF PARTS		
No	Description	Qty	No	Description	Qty
1	Table Top	1	A	JCBC 	8
2	Back Table Legs	2	B	Spring Washer 	8
3	Front Table Legs(Left)	1	C	Flat Washer 	8
4	Front Table Legs(Right)	1	D	Wood Screw 	6
5	Long stretchers	1	E	Allen Key 	1
6	Short stretchers	2			

**NOTE:** The quantities above are the correct amount to complete the assembly. In some cases more fittings may be supplied than are required.

## Bar Chair Assembly

### STEP 1

Use a clean, flat, soft surface to avoid any bumps or scratches.

First add the x4 wooden dowels [D] into the seat x2 chair 'aprons' [3].

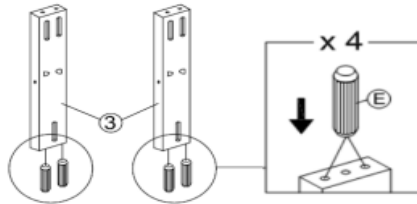

### STEP 2

Attach 2x seat aprons to chair back [1] (apron end with no dowels). Secure with 2x spring washers + 2x bolts [A] on each side - 4 in total.

Attach 2x front legs [2] to other end of seat aprons. Secure with 1x spring washer [B] + 1x bolt [A] on each side - 2 in total.

Carefully slot 2x stretchers [5] into place between the lower legs.

Once everything is in place, tighten bolts with Allen key [D] but avoid over-tightening.

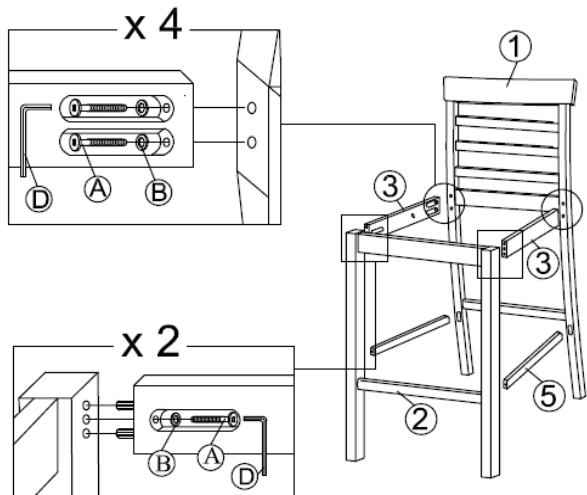

## STEP 3

Secure the leg stretchers with 4x wood screws [C].  
Then attach the chair seat [4] - you may find it easier to turn the chair upside down and use the edge of a table for support. Secure chair seat with 3x wood screws [C].

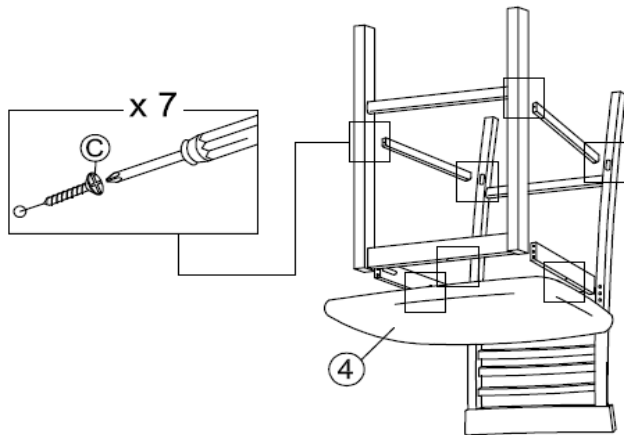

## STEP 4

Use a clean, flat, soft surface to avoid any bumps or scratches.

Repeat for the 2nd chair.

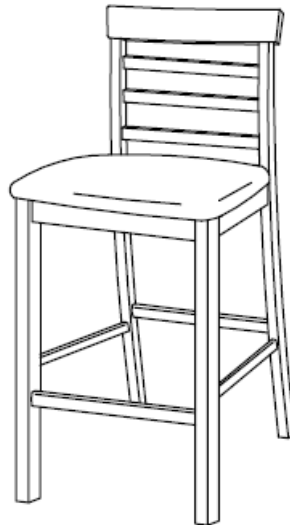

## Bar Table Assembly

### STEP 1

Use a clean, flat, soft surface to avoid any bumps or scratches.

Place the tabletop [1] face down. Connect the 'long stretcher' [5] to the 2x back legs [2] - the stretcher will slot into the pre-drilled holes on the legs.

Then attach the 2x back legs [2] to the tabletop [1]. Align the pre-drilled holes and connect each leg using 2x flat washers [C] followed by 2x spring washers [B] and 2x bolts [A] per leg. Tighten with Allen key [E].

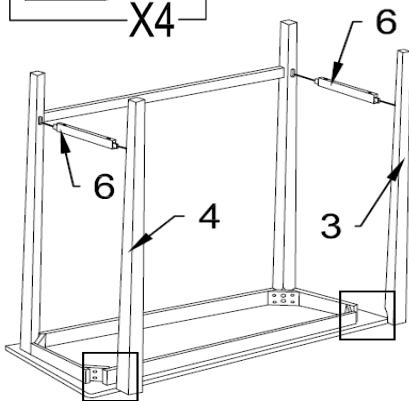
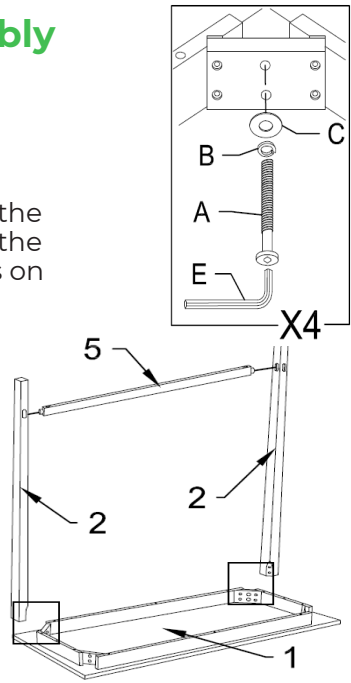
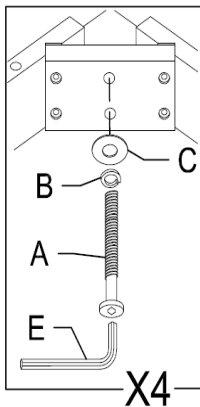

### STEP 2

Attach the 2x short 'stretchers' [6] to the back legs and the 2x front legs [3] and [4]. Note leg [3] is front left and leg [4] is front right.

Connect the front legs to the tabletop. Align the pre-drilled holes and connect each leg using 2x flat washers [C] followed by 2x spring washers [B] and 2x bolts [B] per leg. Tighten with Allen key [E].

Connect the front legs to the tabletop. Align the pre-drilled holes and connect each leg using 2x flat washers [C] followed by 2x spring washers [B] and 2x bolts [B] per leg. Tighten with Allen key [E].

### STEP 3

Secure the long and short stretchers to the legs using 6x wood screws [D] into the pre-drilled holes.

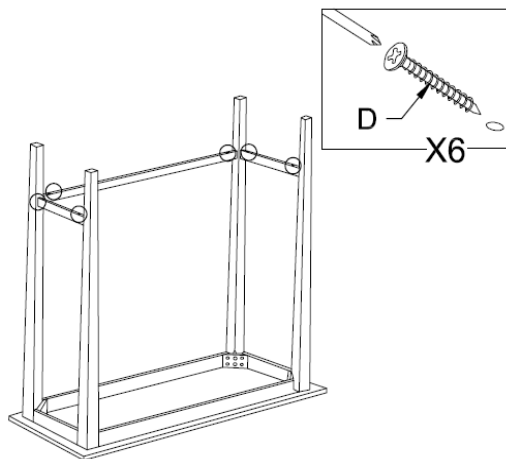

### STEP 4

Carefully and with help, flip your table upright onto its legs. Check for stability. Your new table is now ready to use.

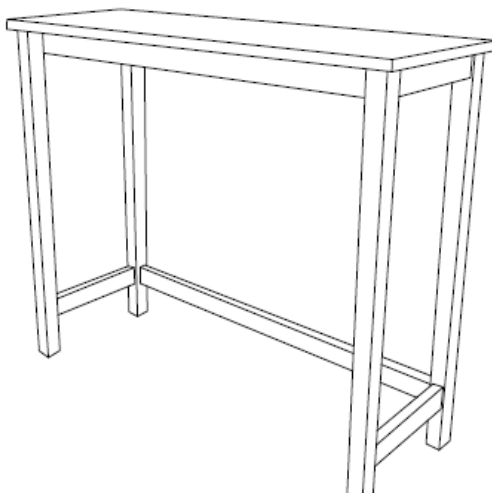



## OUR 2 YEAR\* GUARANTEE

our products come with a 2 year guarantee to give you peace of mind shopping at

\*excludes some garden furniture items which have a 1 year guarantee



## WHAT THE GUARANTEE COVERS



**PRE-INSERTED FIXINGS**  
e.g. lose metal threads



**FAULTY JOINTS**  
e.g. legs bending



**EXTERNAL FIXING FAULTS**  
e.g. bonding/glue



**STRUCTURAL INTEGRITY**  
e.g. the frame of the product