

Assembly Instruction

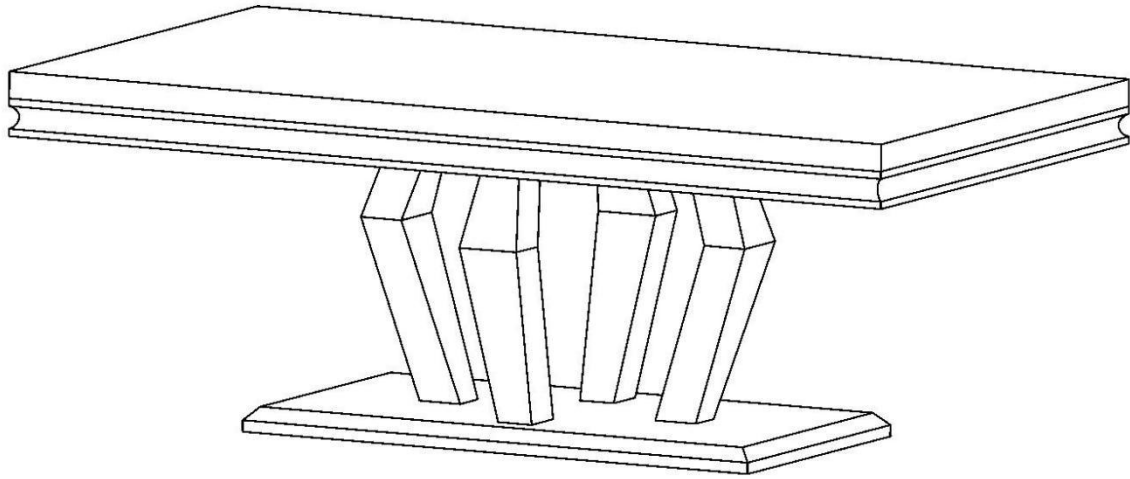

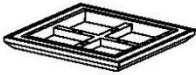

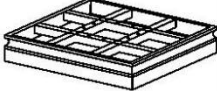
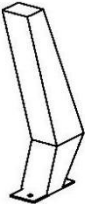

ASSEMBLY TIME PER UNIT: 20 MINUTES

PARTS IDENTIFICATION

A	BASE		1PC	B	TOP		1PC
C	LEGS		4PCS				

HARDWARE LIST

NO.	SIZE	DIAGRAM	QTY	NO.	SIZE	DIAGRAM	QTY
1	Allen wrench		1	3	Bolts M8x16		8
2	Bolts M8x40		12	4	Flat washer		20

STEP1

tighten all the screws to 90%.

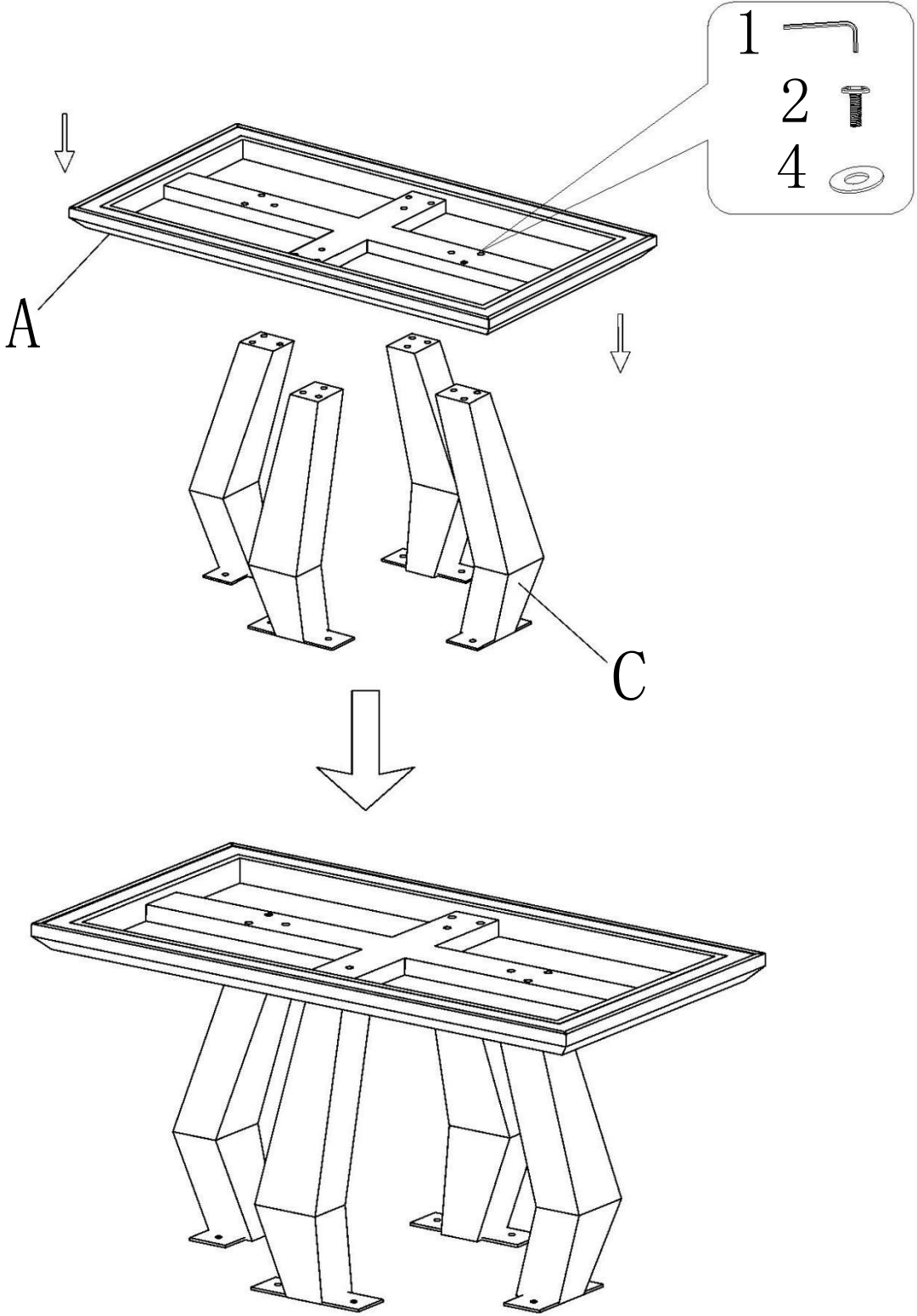

STEP2

tighten all the screws to 90%.

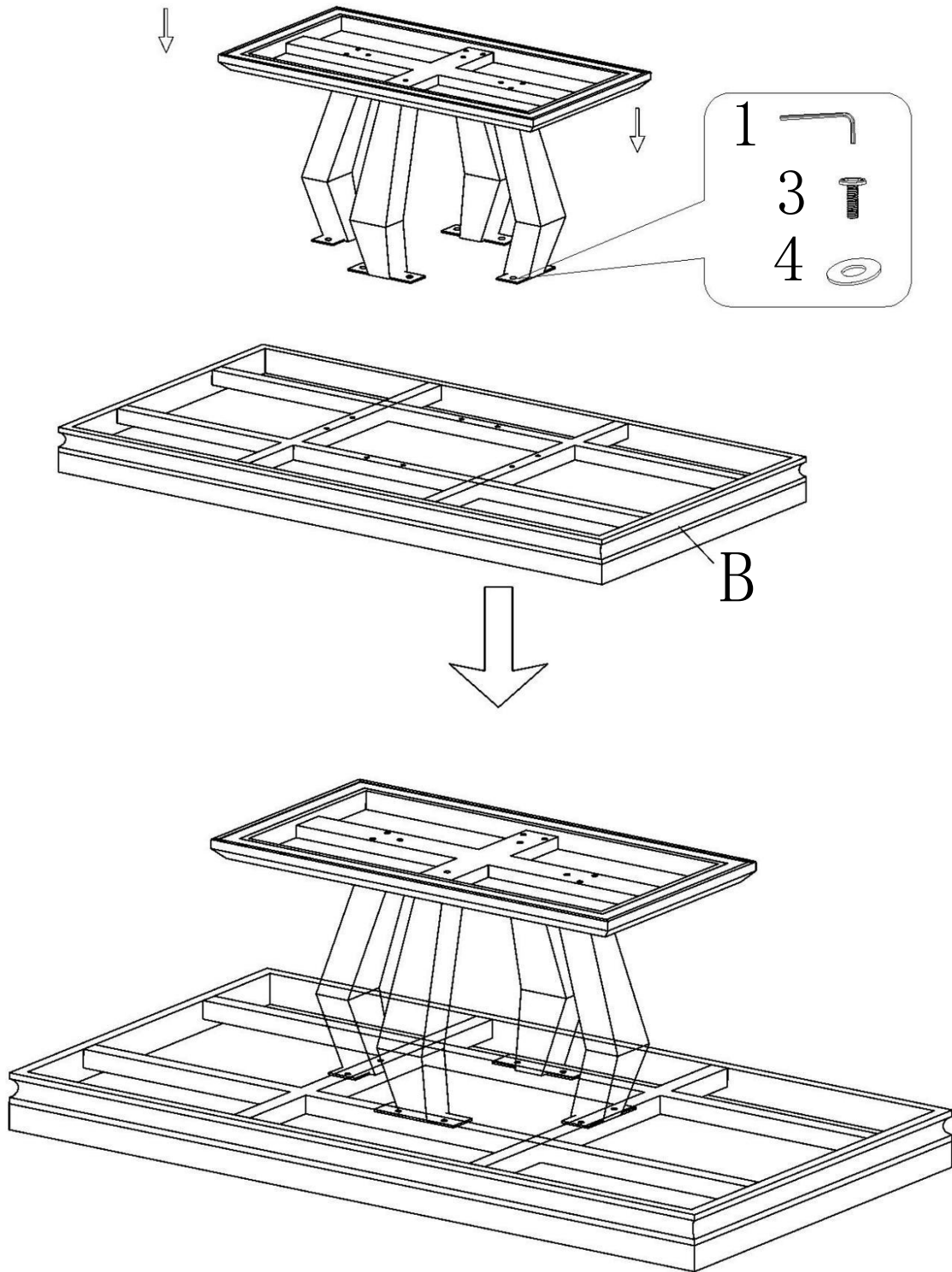

STEP3

tighten all the screws to 100%.

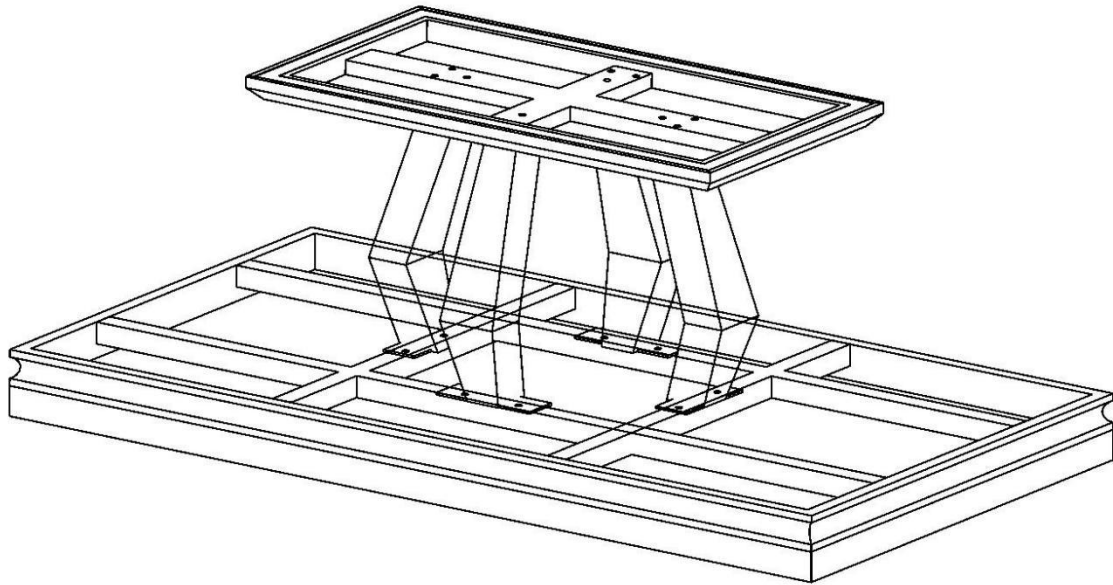

COMPLETED

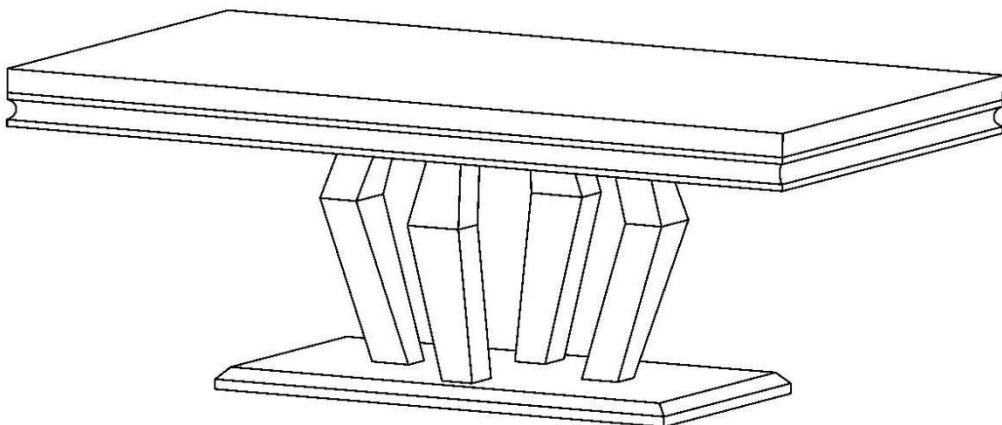

THE BOTTOM FIXED ADJUSTMENT FEETS