

ASSEMBLY INSTRUCTION

INSTRUCTIONS DE MONTAGE

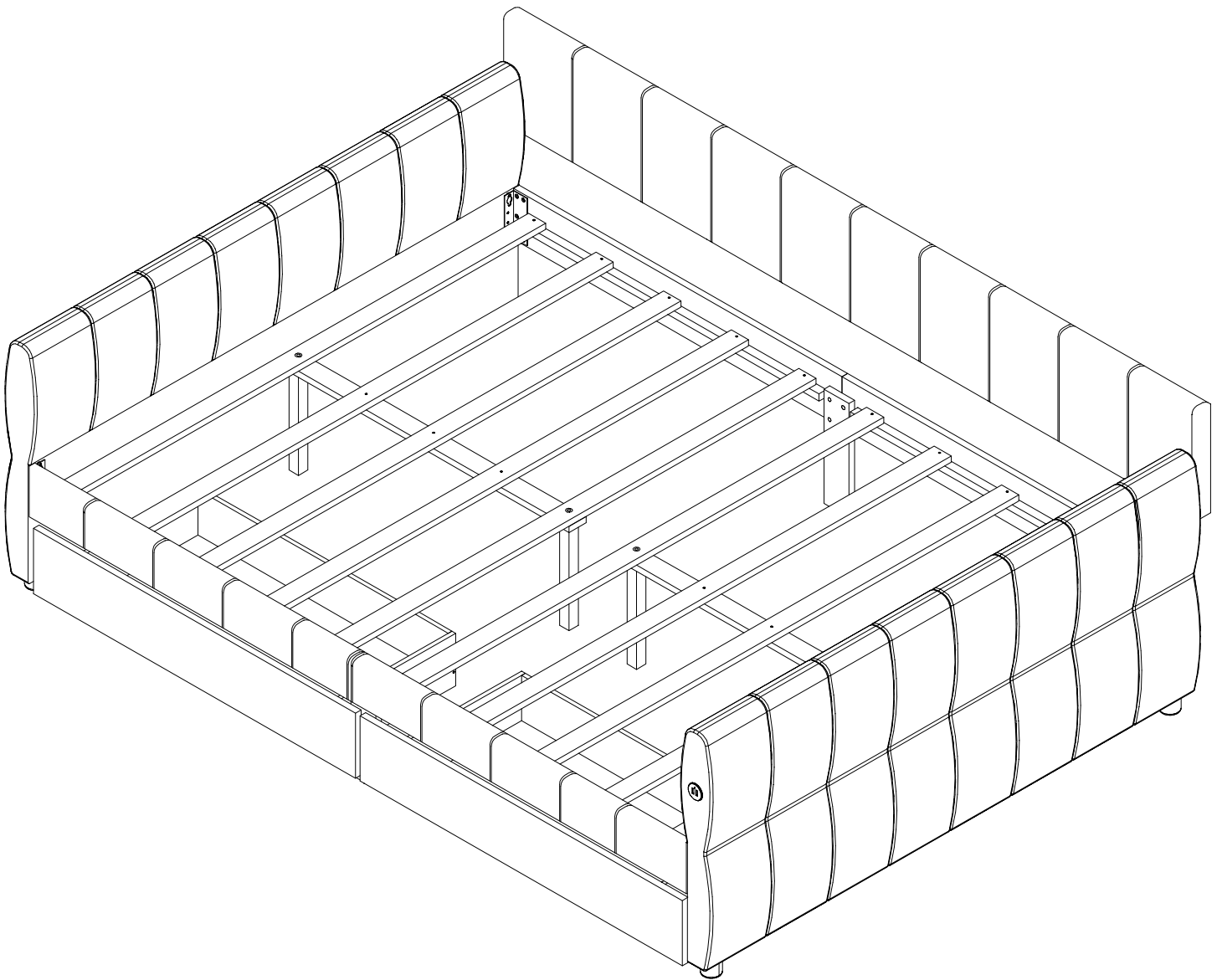

ASSEMBLY INSTRUCTION

INSTRUCTIONS DE MONTAGE

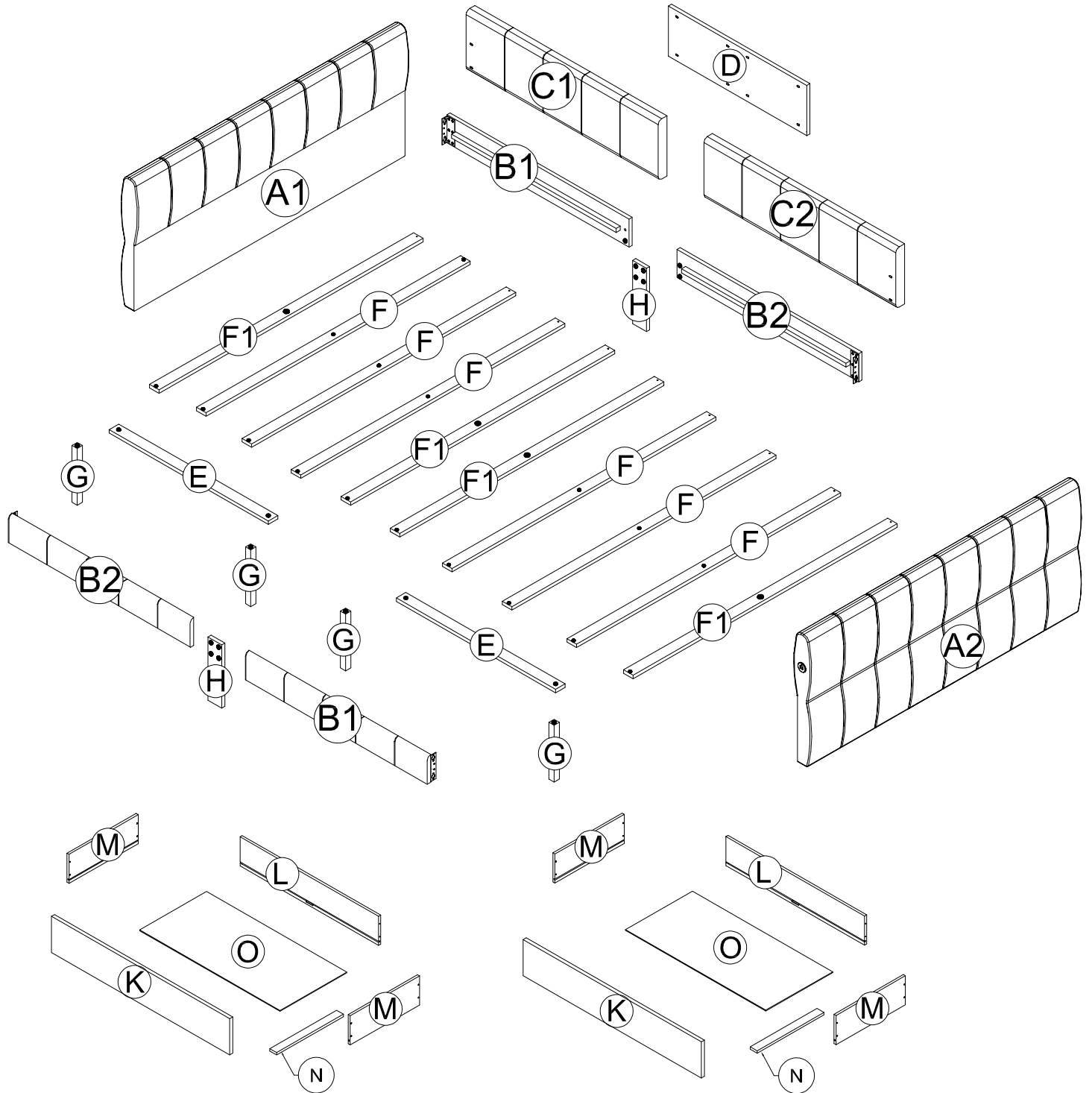

Part List

Liste des pièces

A1

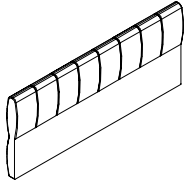

Left Arm-1pcs
Bras gauche-1pièces

E

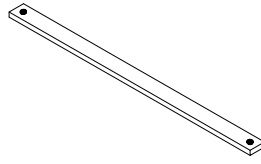

Support Bar-1pcs
Barre de support -1pièces

F

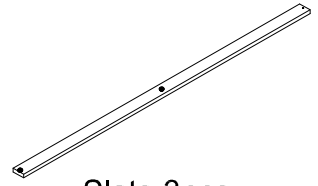

Slats-3pcs
Lattes-3pièces

F1

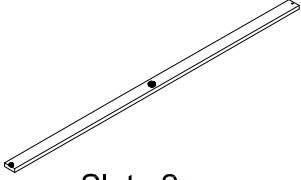

Slats-2pcs
Lattes-2pièces

M

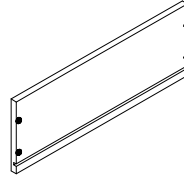

Drawer-Side Panels- 2 pcs
Panneaux latéraux de tiroir - 2 pièces

L

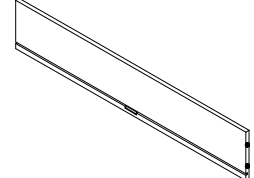

Drawer - Back Panels - 1 pcs
Tiroir - Panneaux arrière - 1 pièces

Part List

Liste des pièces

A2

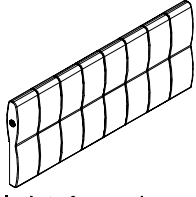

Right Arm-1pcs
Bras droit-1pièces

E

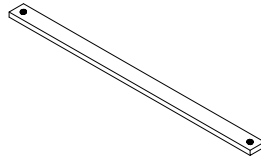

Support Bar-1pcs
Barre de support -1pièces

F

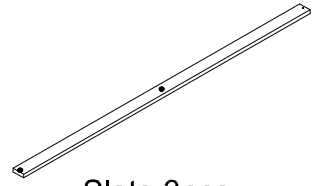

Slats-3pcs
Lattes-3pièces

F1

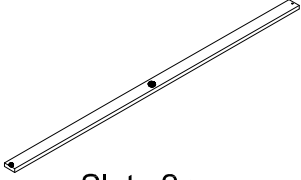

Slats-2pcs
Lattes-2pièces

M

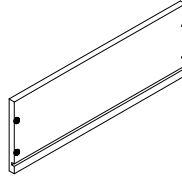

Drawer-Side Panels- 2 pcs
Panneaux latéraux de tiroir - 2 pièces

L

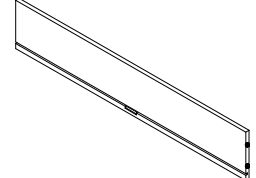

Drawer - Back Panels - 1 pcs
Tiroir - Panneaux arrière - 1 pièces

Part List

Liste des pièces

B1



Side rails - 2pcs
Rails latéraux - 2 pièces

B2



Side rails - 2pcs
Rails latéraux - 2 pièces

C1

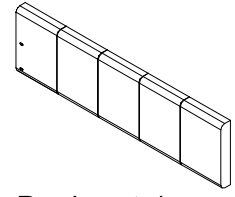

Backrest-1pcs
dossier-1pièces

C2

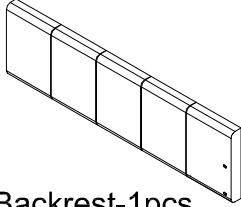

Backrest-1pcs
dossier-1pièces

D

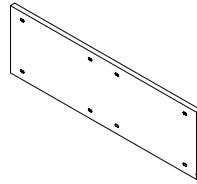

Link plate - 1 pc
Plaque de liaison - 1 pièce

G



Legs Support-4pcs
Support de jambes-4pièces

H



Legs Support-2pcs
Support de jambes-2pièces

K

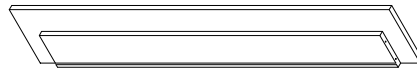

Drawer - Front Panels - 2 pcs
Tiroir - Façades - 2 pièces

N

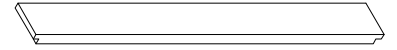

Drawers - Support Bottom - 2pcs
Tiroirs - Support Fond - 2 pièces

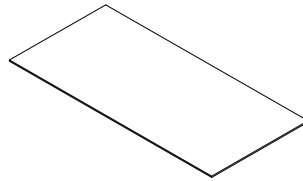

O



Panel - 2 pcs
Panneau - 2 pièces

Hardware List

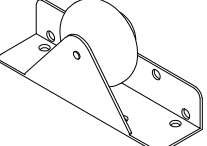
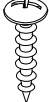
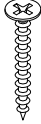
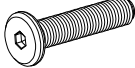
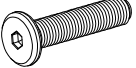
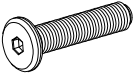
Liste du matériel

<p>1</p>  <p>Plastic Feet(Ø50x40) 4pcs Pieds en plastique (Ø50x40) 4pièces</p>	<p>2</p>  <p>Wheels 8pcs Roues 8pièces</p>	<p>3</p>  <p>M4 x 12 mm Wood Screws 20 pcs Vis à bois M4 x 12 mm 20 pièces</p>
<p>4</p>  <p>M4 x 30 mm Wood Screws 42 pcs Vis à bois M4 x 30 mm 42 pièces</p>	<p>5</p>  <p>Ø1/4" x 50mm Hex-Head bolts 8 pcs Boulons à tête hexagonale Ø1/4" x 50mm 8pièces</p>	<p>6</p>  <p>Ø1/4" x 35mm Hex-Head bolts 16pcs Ø1/4" x 35mm Hex-Head bolts 16pièces</p>
<p>7</p>  <p>Ø1/4" x 30 mm Hex-Head bolts 8 pcs Boulons à tête hexagonale Ø1/4" x 30 mm 8pièces</p>	<p>8</p>  <p>Allen Key 1 pcs Clé Allen 1 pièces</p>	<p>9</p>  <p>Plastic Drawer Stopper 4 pcs Bouchon de tiroir en plastique 4 pièces</p>

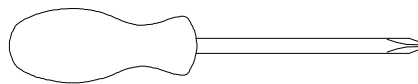

Assembly Tools Required (Not Included)
Outils d'assemblage requis (non inclus)

STEP 1: Following below illustration:

ÉTAPE 1: Suivant l'illustration ci-dessous:

1

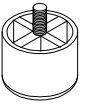

4pcs

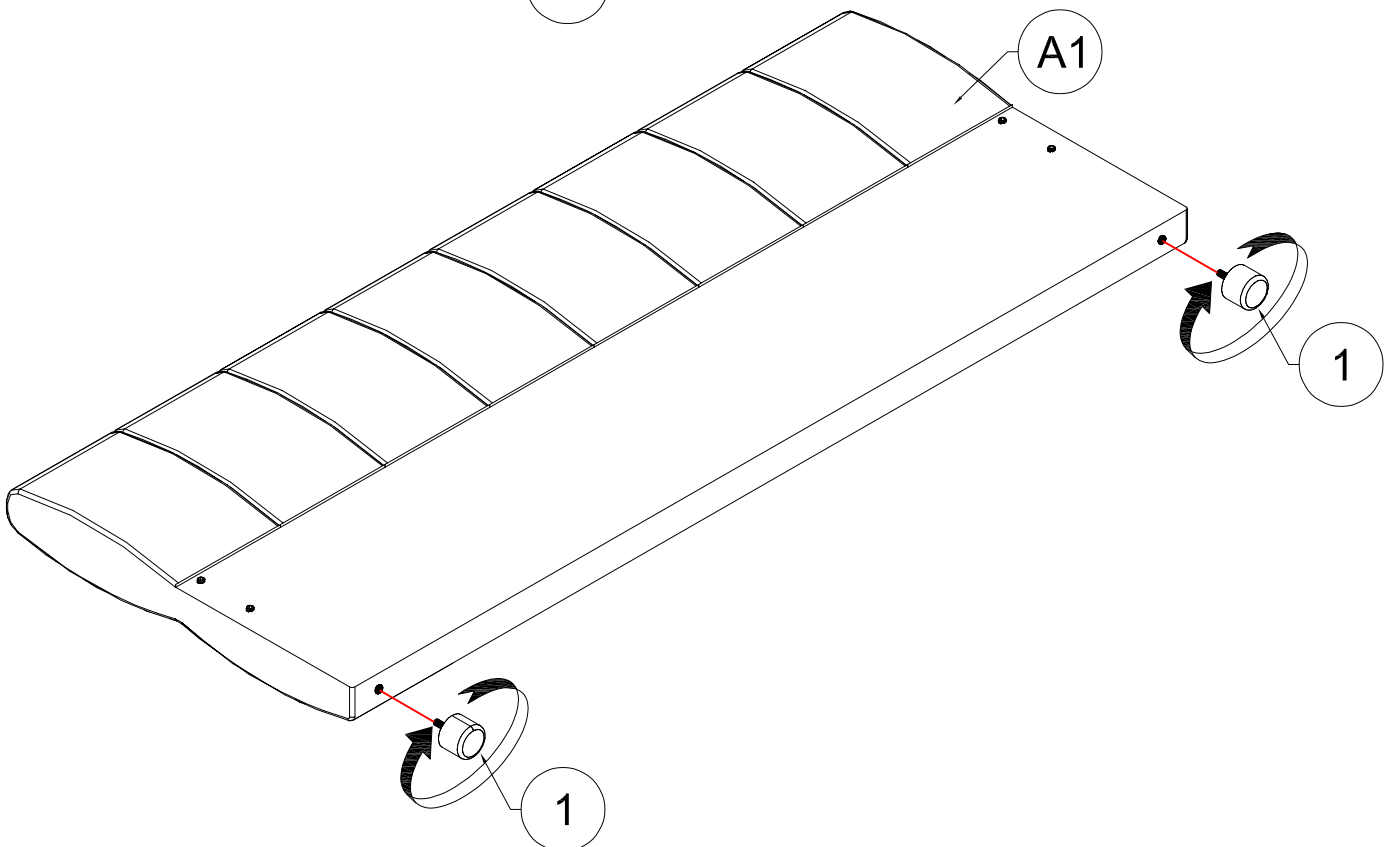
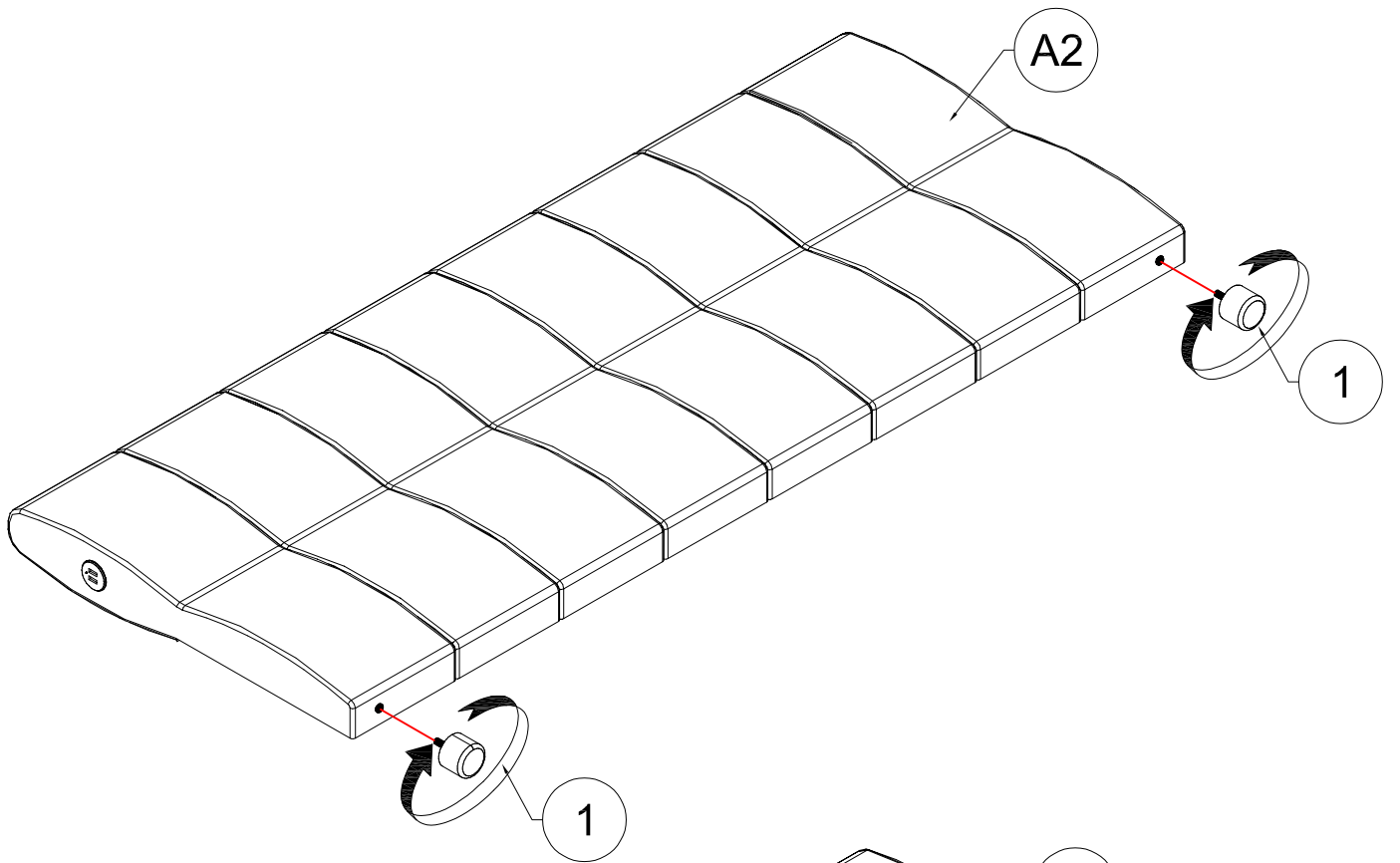

STEP 2: Following below illustration:

ÉTAPE 2: Suivant l'illustration ci-dessous:

6

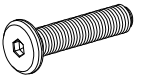

8pcs

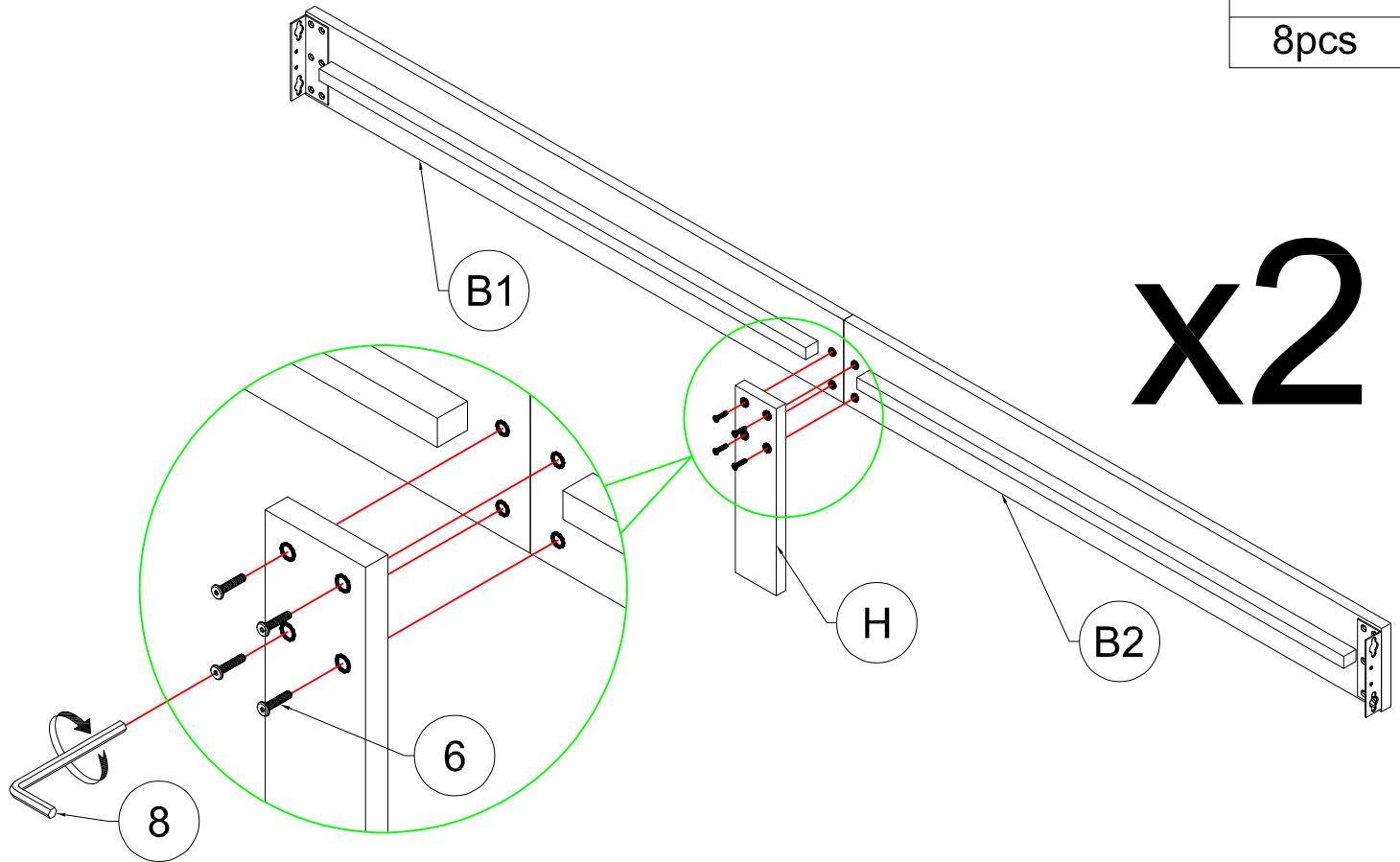

STEP 3: Following below illustration:

ÉTAPE 3: Suivant l'illustration ci-dessous:

6

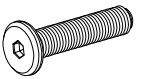

8pcs

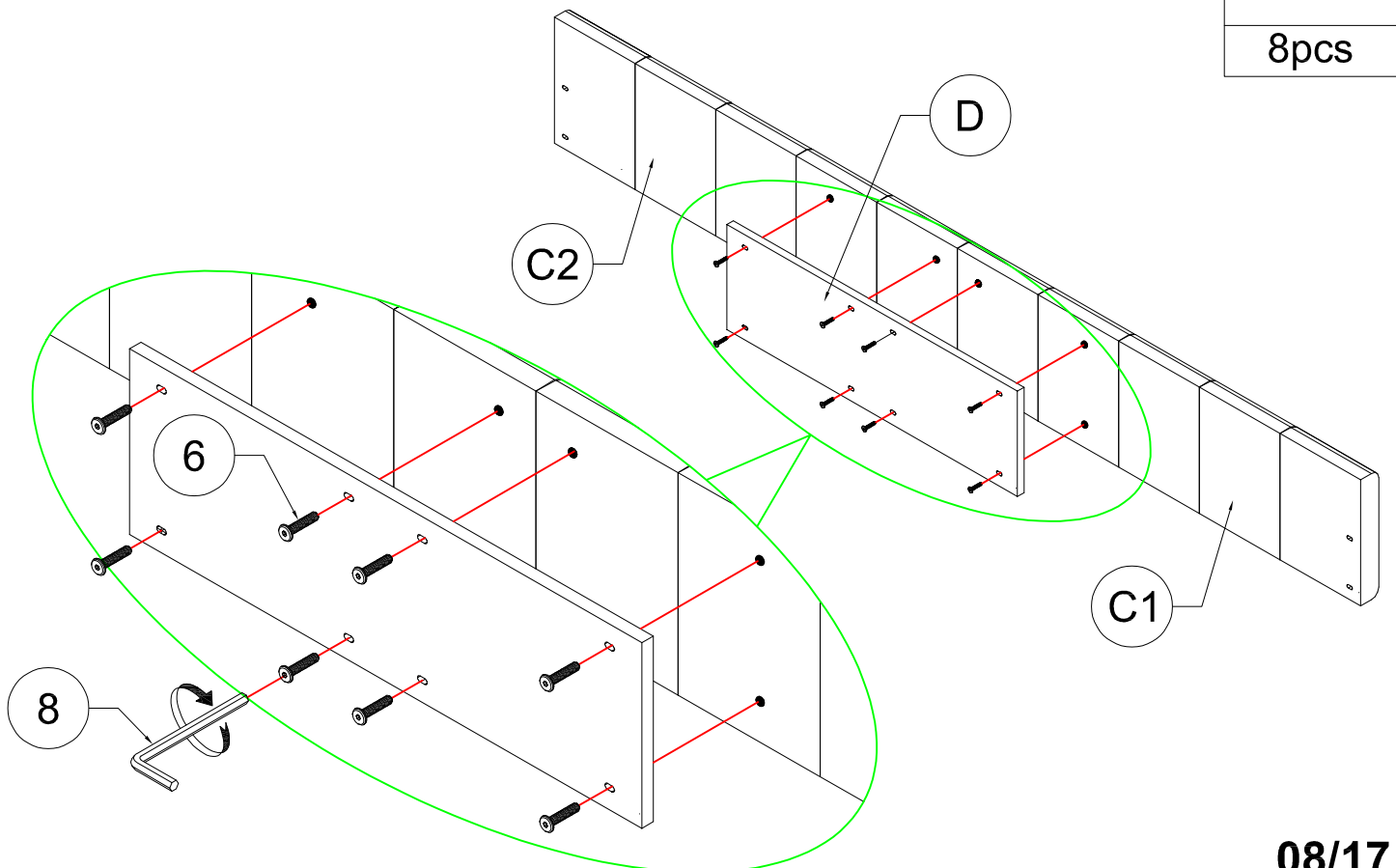

STEP 4: Following below illustration:

ÉTAPE 4: Suivant l'illustration ci-dessous:

7

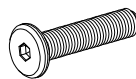

8pcs

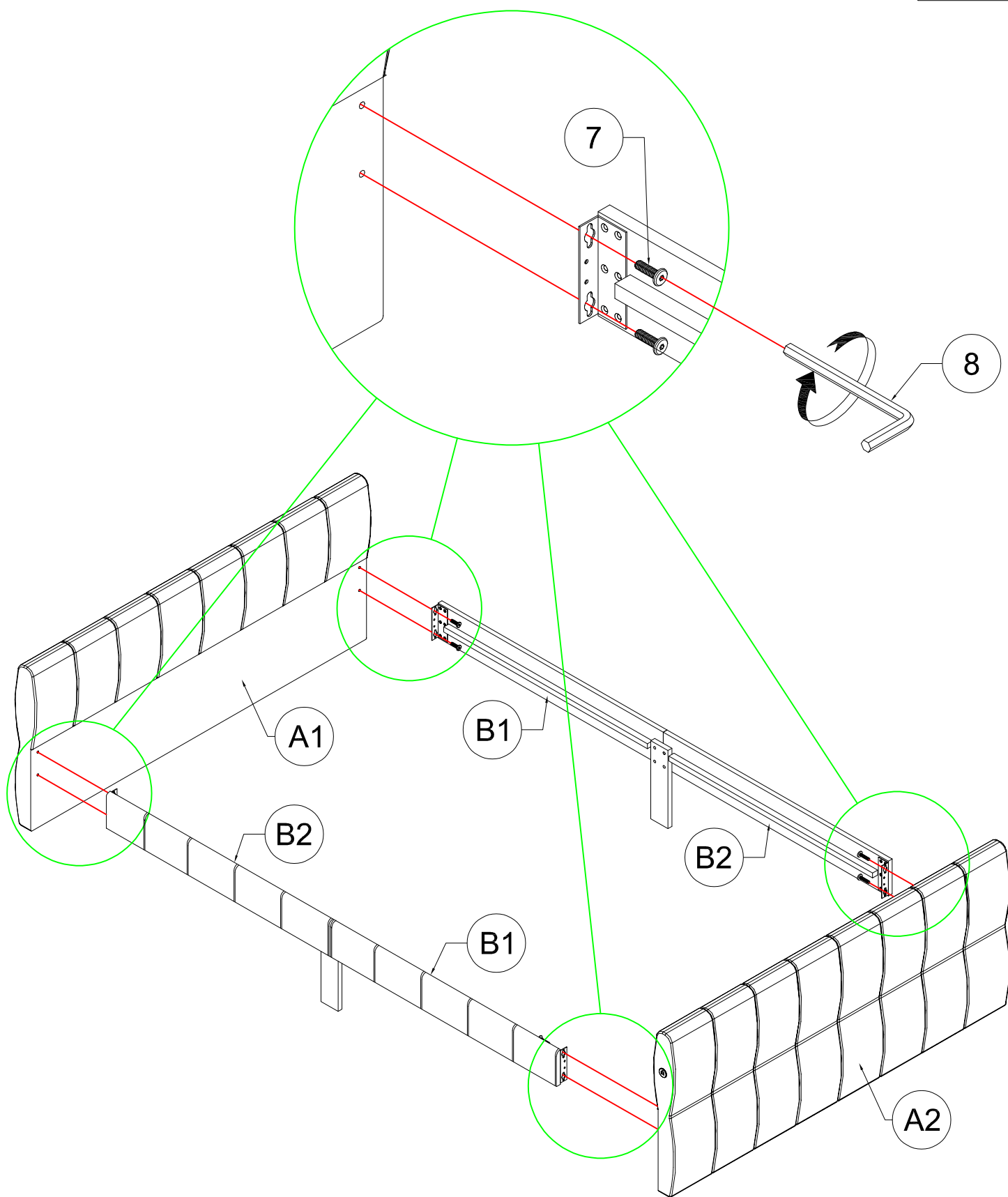

STEP 5: Following below illustration:

ÉTAPE 5: Suivant l'illustration ci-dessous:

3



4pcs

9



4pcs

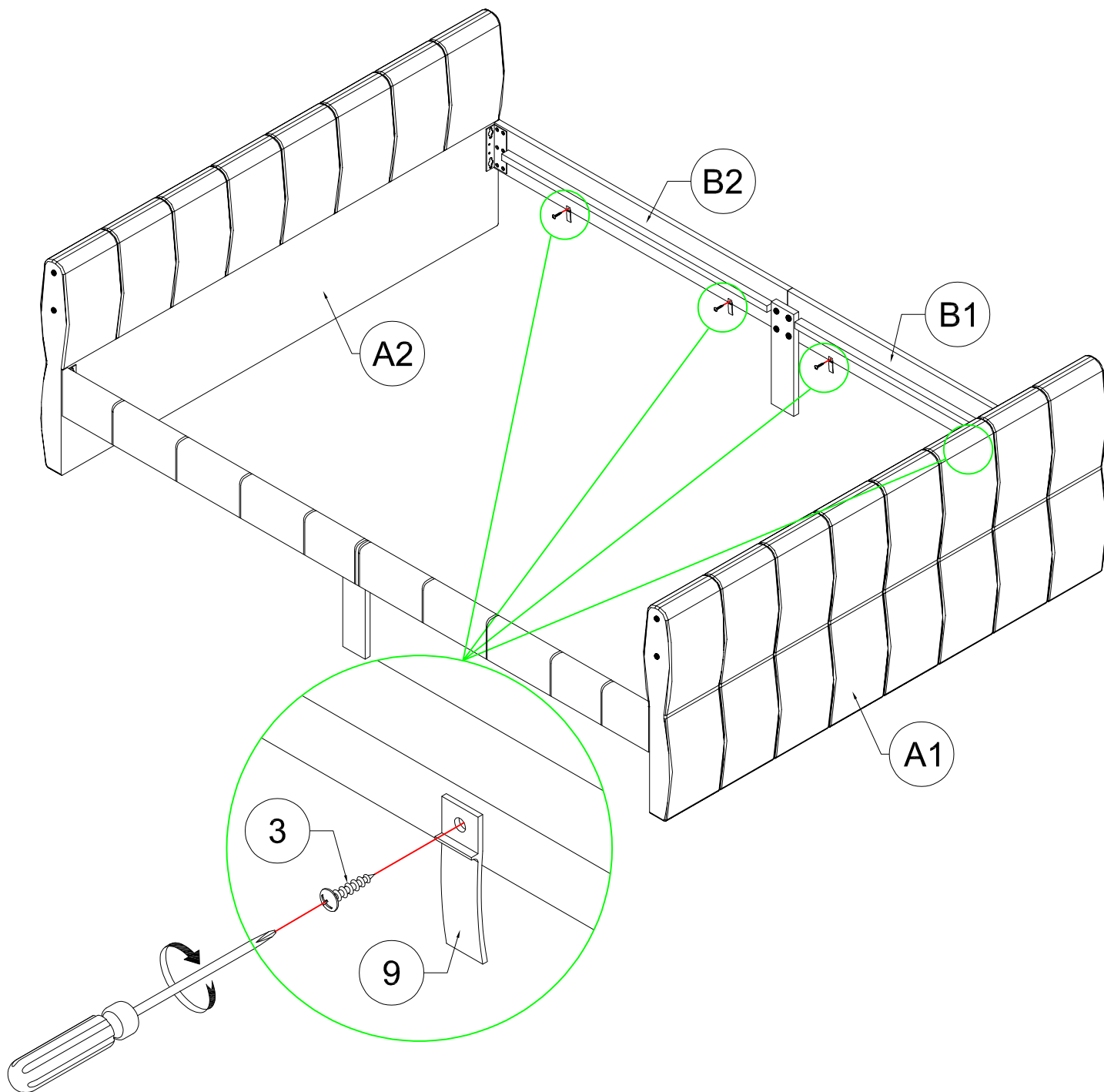

STEP 6: Following below illustration:

ÉTAPE 6: Suivant l'illustration ci-dessous:

5

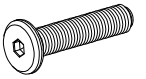

4pcs

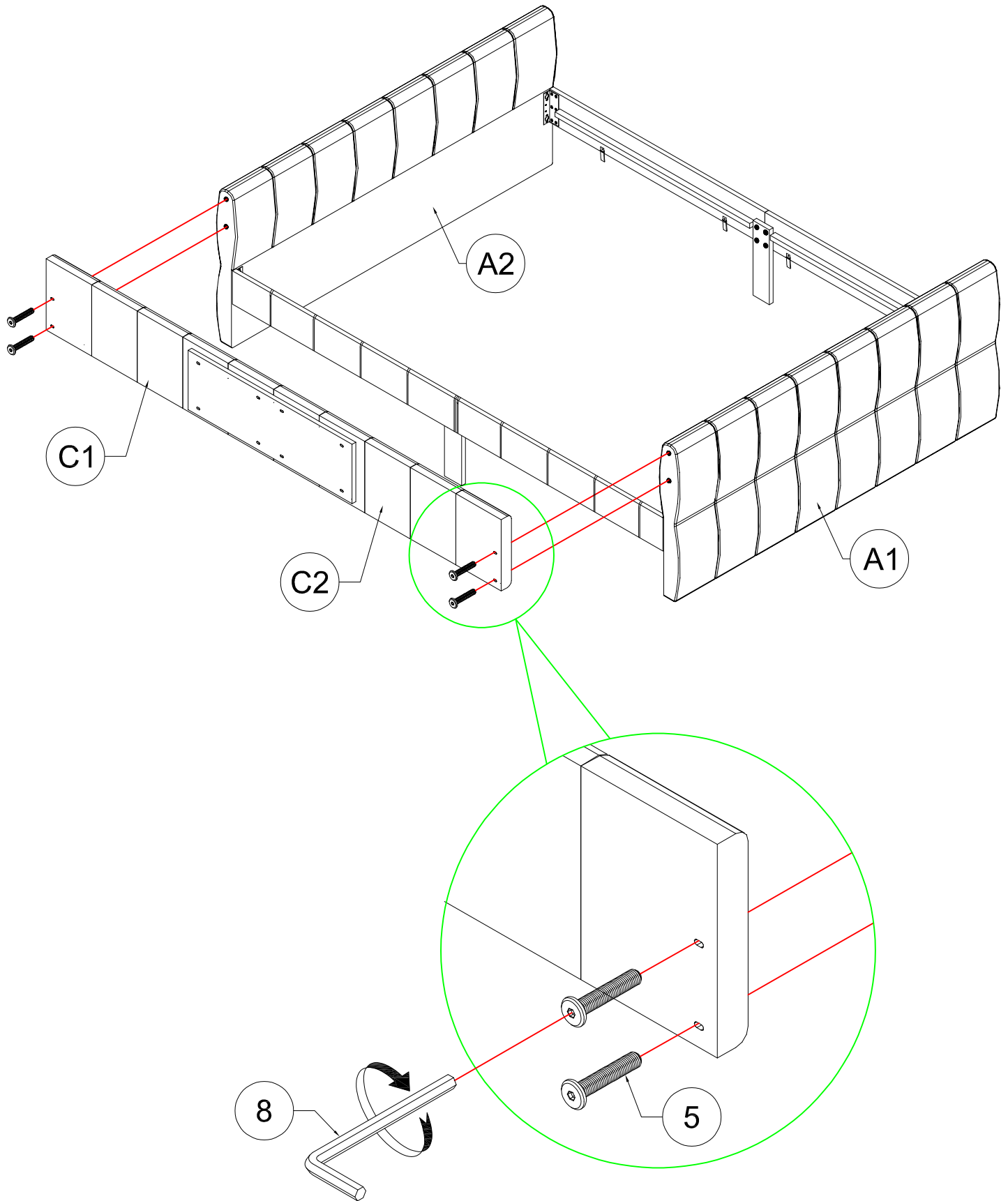

STEP 7: Following below illustration:

ÉTAPE 7: Suivant l'illustration ci-dessous:

5

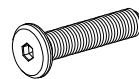

4pcs

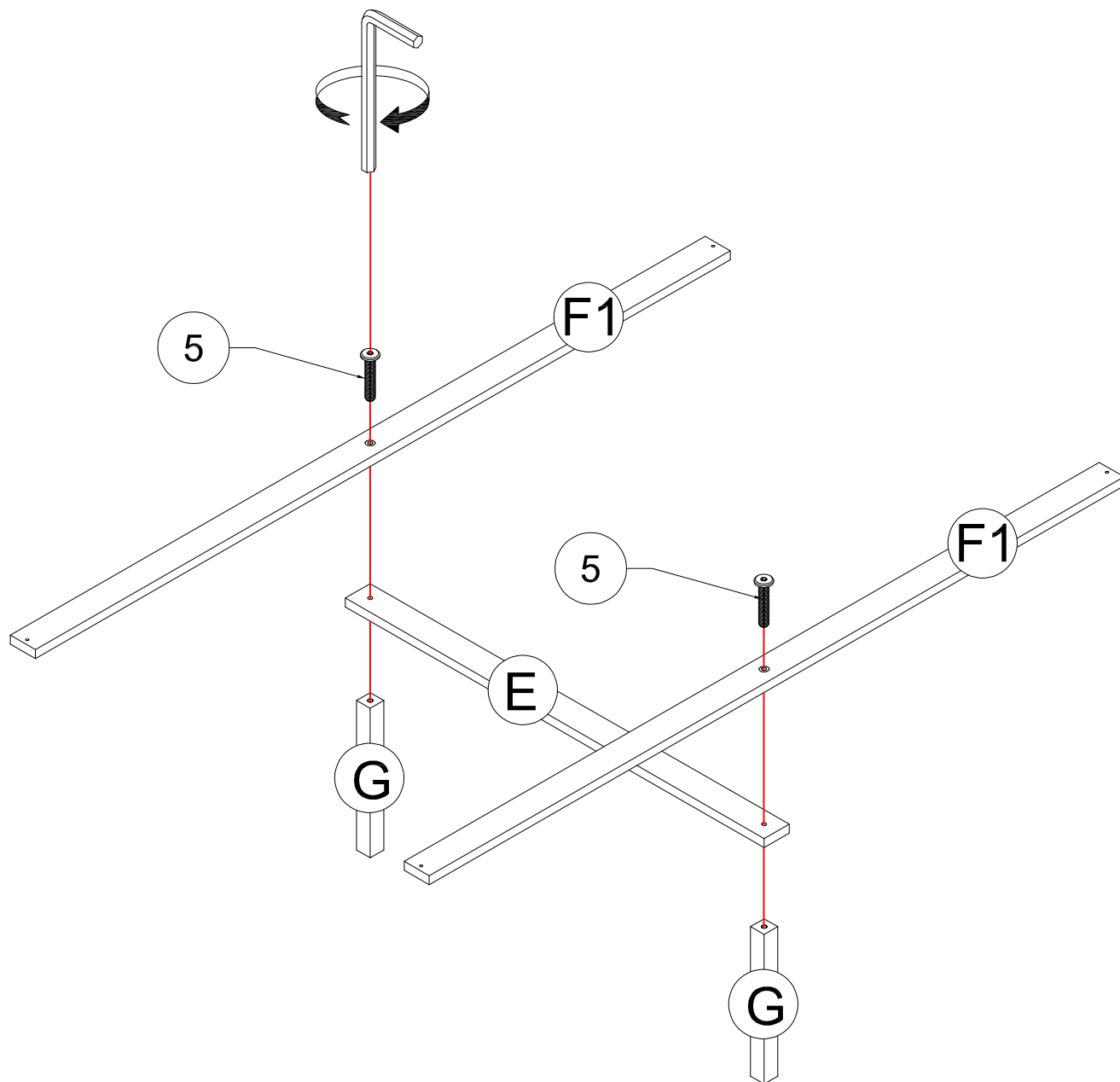

x2

STEP 8: Following below illustration:

ÉTAPE 8: Suivant l'illustration ci-dessous:

4



8pcs

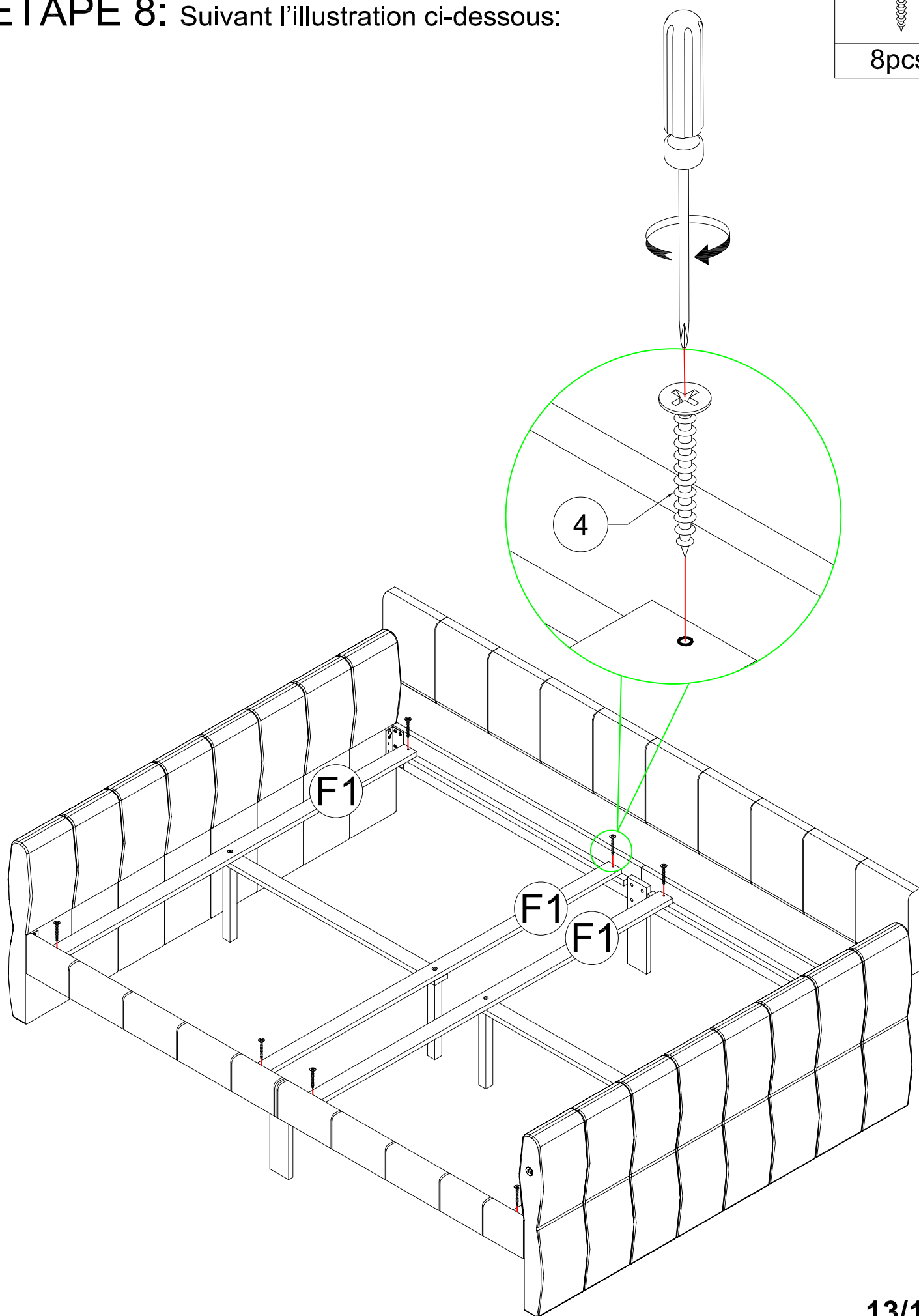

STEP 9: Following below illustration:

ÉTAPE 9: Suivant l'illustration ci-dessous:

4

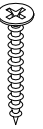

18pcs

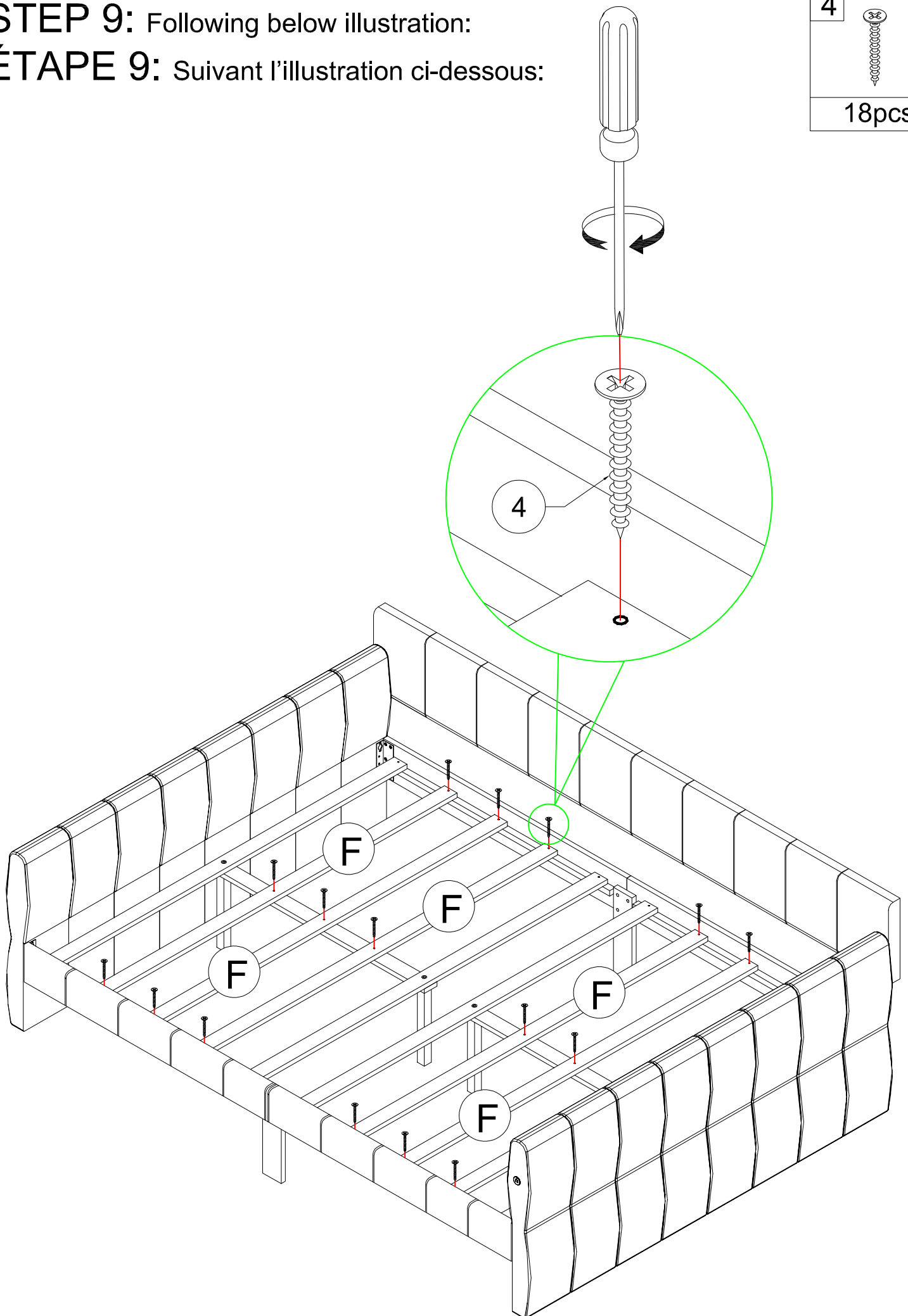

STEP 10.1: Following below illustration:

ÉTAPE 10.1: Suivant l'illustration ci-dessous:

4



8pcs

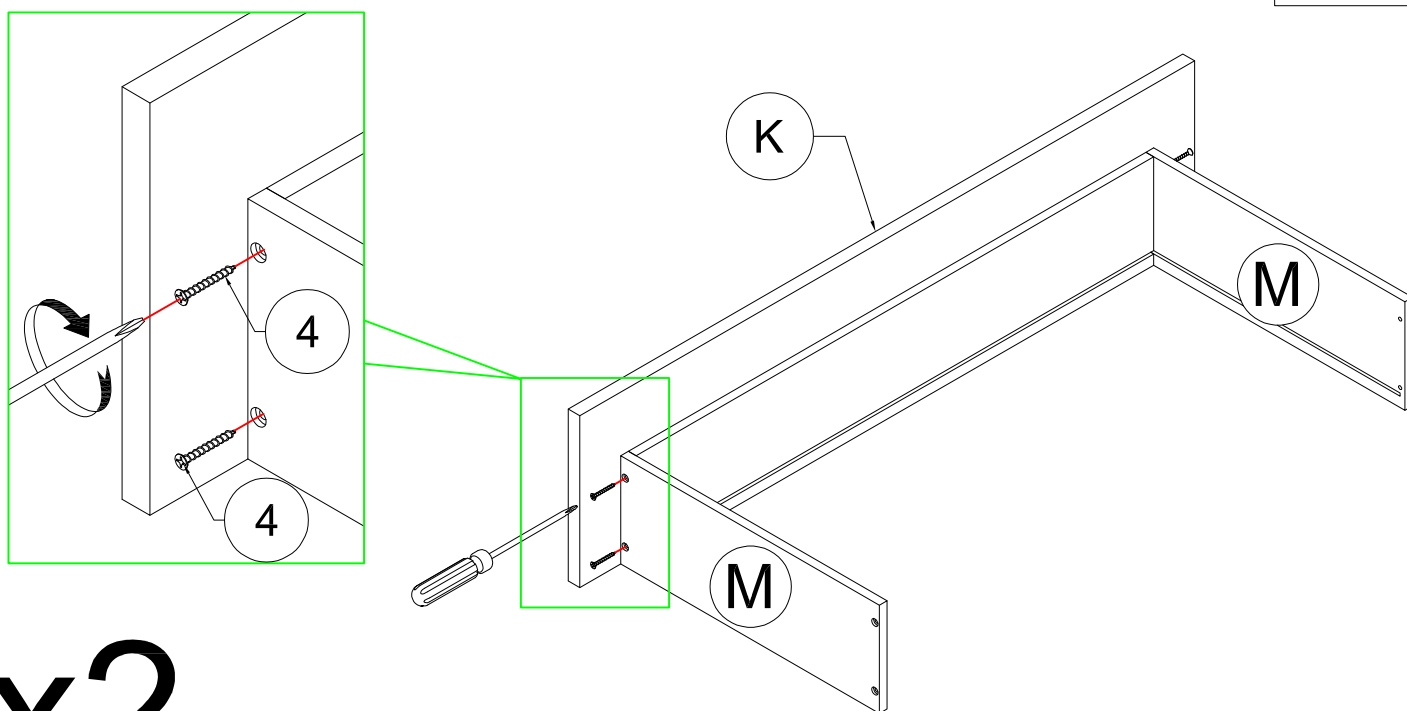

x2

STEP 10.2: Following below illustration:

ÉTAPE 10.2: Suivant l'illustration ci-dessous:

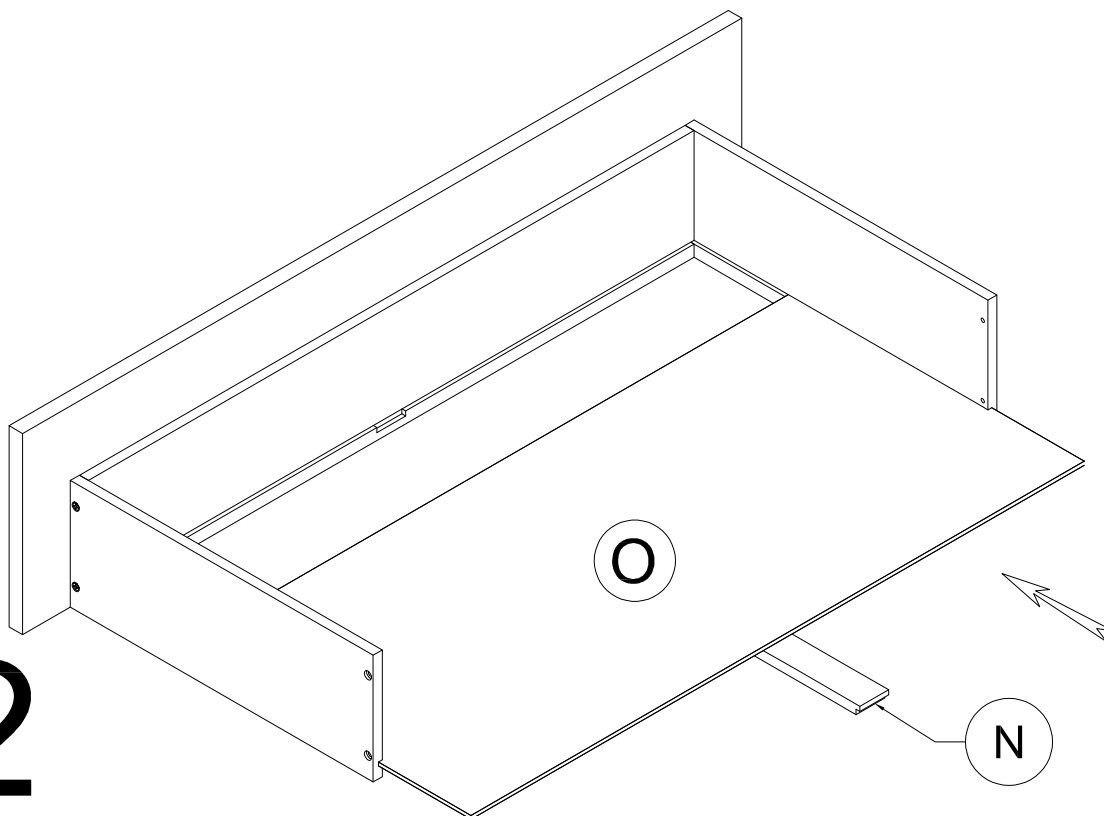

x2

STEP 10.3: Following below illustration:

ÉTAPE 10.3: Suivant l'illustration ci-dessous:

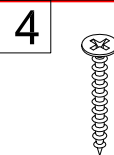

8pcs

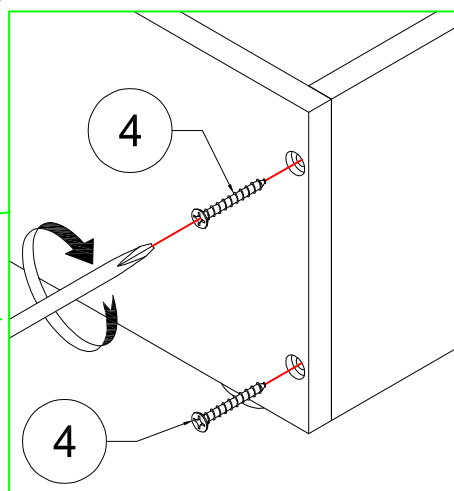
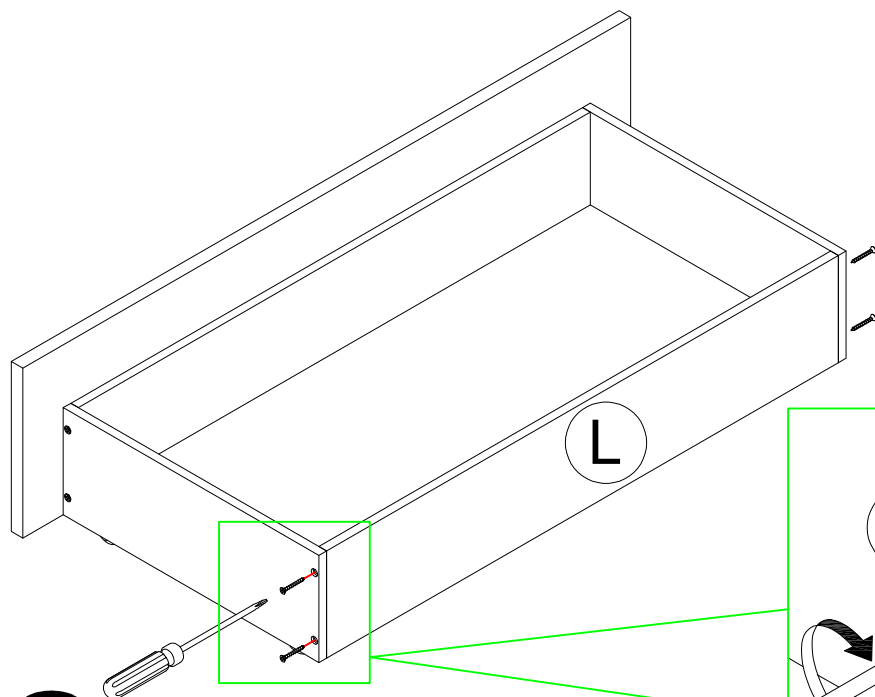

x2

STEP 10.4: Following below illustration:

ÉTAPE 10.4: Suivant l'illustration ci-dessous:

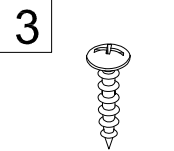

16pcs

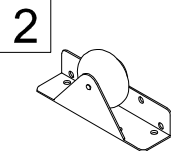

8pcs

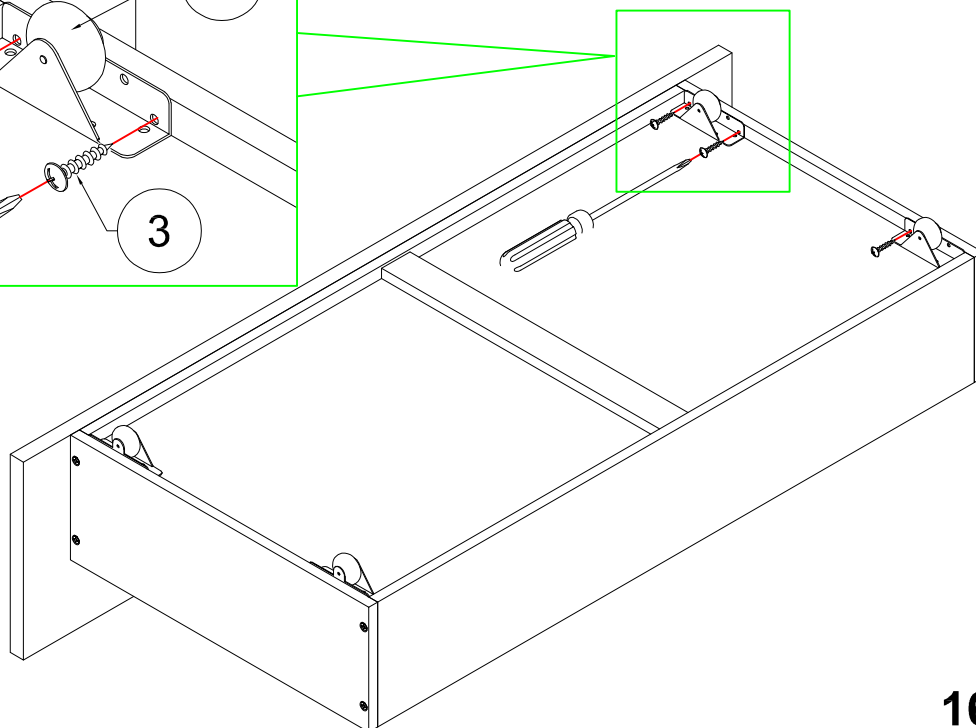
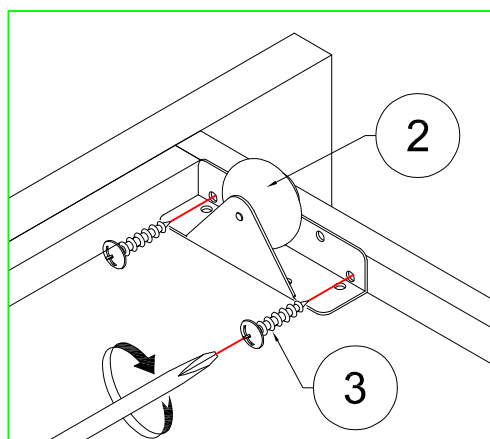

x2

FINISH FINITION

