

INSTRUCTION

4 PIECE OUTDOOR PATIO FURNITURE SET

If you have any problem, include return needs,
please contact us for after-sale service!

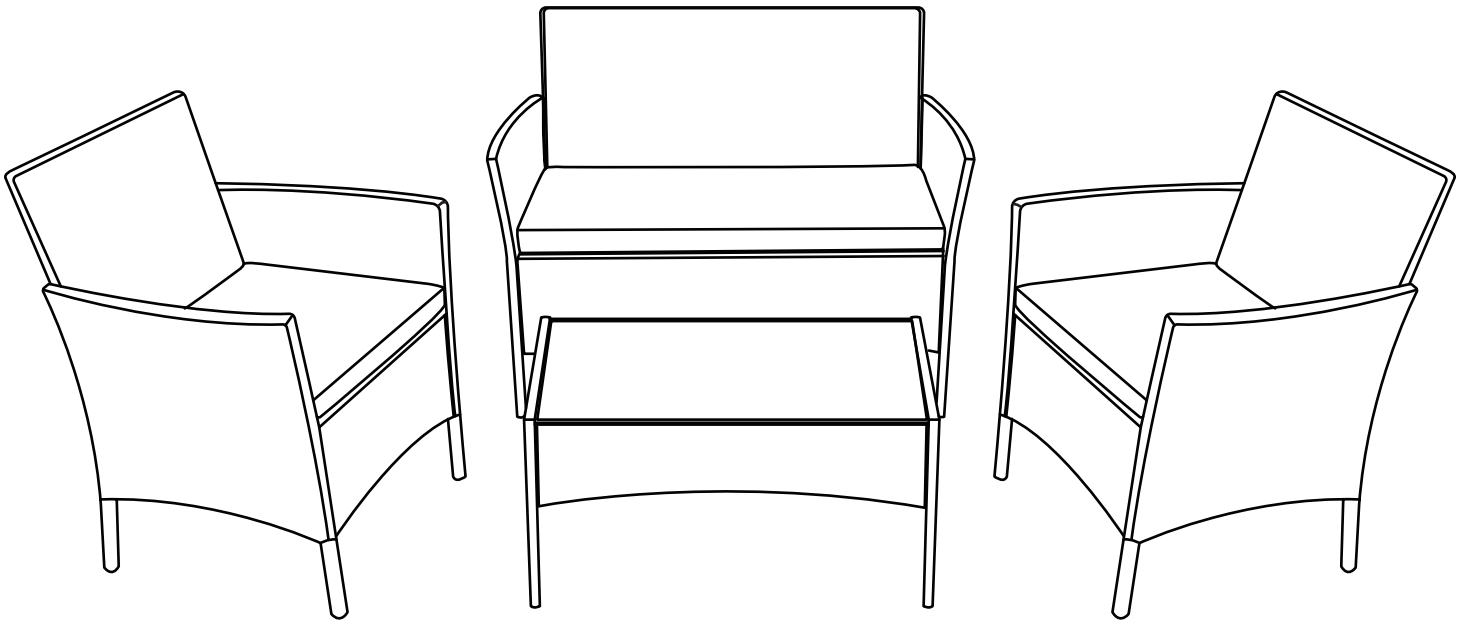

After-sales mailbox:
PatiofurnitureserVICETEAM@outlook.com

NOTICE

Please keep these instructions for future reference.

Dear Customer

- Thank you for your purchase. When you receive the product, please make sure that all the parts are intact. Then follow the entire installation instructions to install!
- There is an installation video on the product page, you can open the product page to view it or contact customer service to receive it.

- A . The outer box is damaged
- B . The product is damaged / bent / cracked while you open the box
- C . The parts / accessories / assembly tools are missing
- D . The instructions are not clear and can not be referred
- E . The product has functional problems
- F . Other aspects that you are not satisfied with

Please feel free to contact us for help. Our after-sales team service (Patiofurniture Serviceteam@outlook.com) will reply within 24 hours and will do our best to resolve the problem for you.

Warm tip: All the screws are tightened to 80% first during installation process. After aligning all the screw holes, tighten them again.



PART LIST

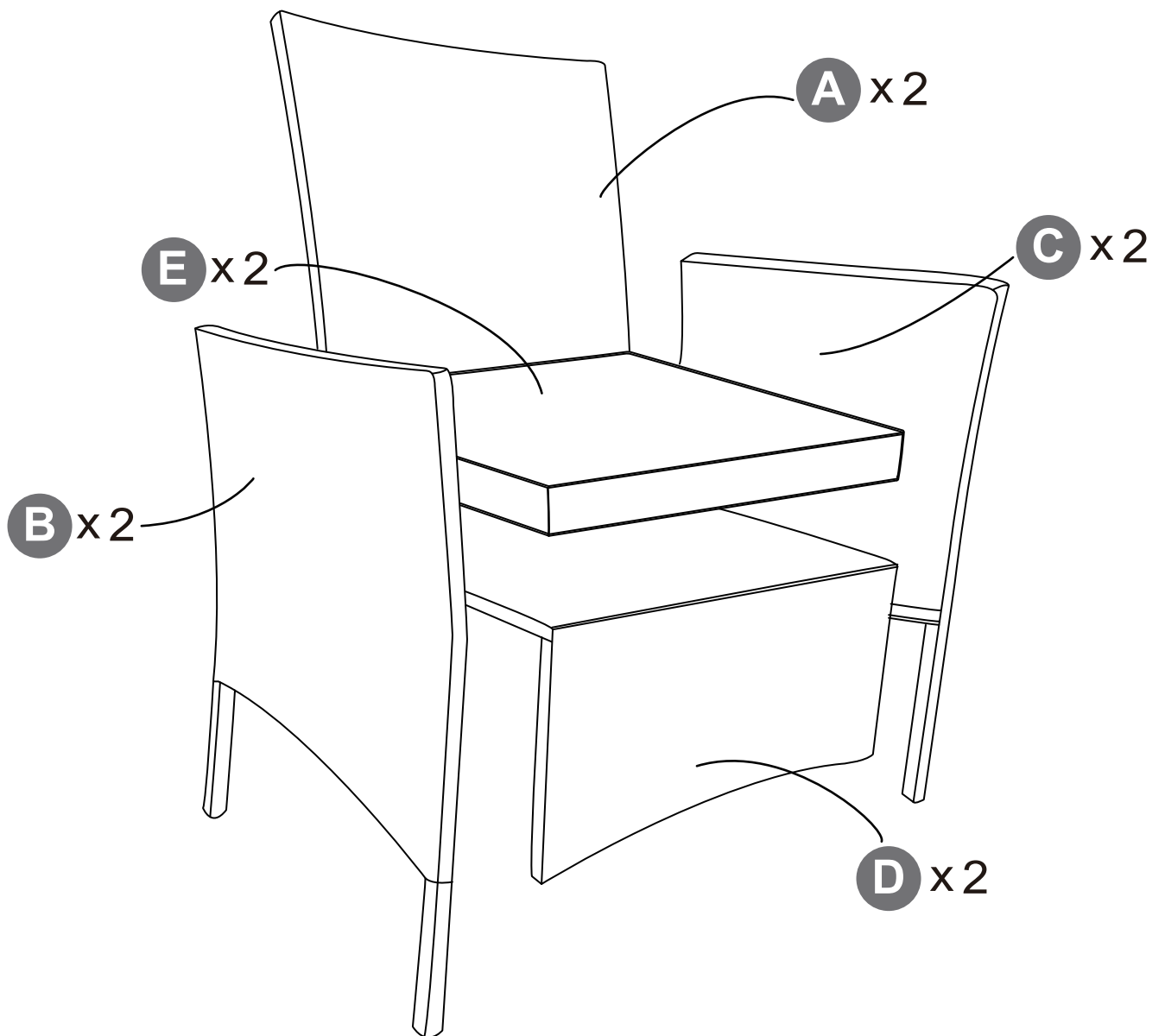

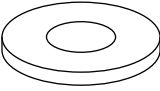
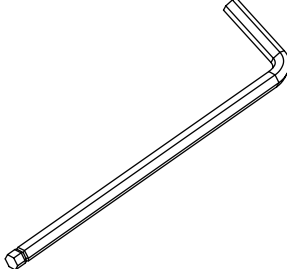
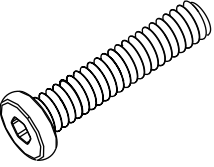
<p>2</p>  <p>x 22</p>	<p>3</p>  <p>x 1</p>	<p>4</p>  <p>M6*35MM</p> <p>x 22</p>
---	--	--

PART LIST

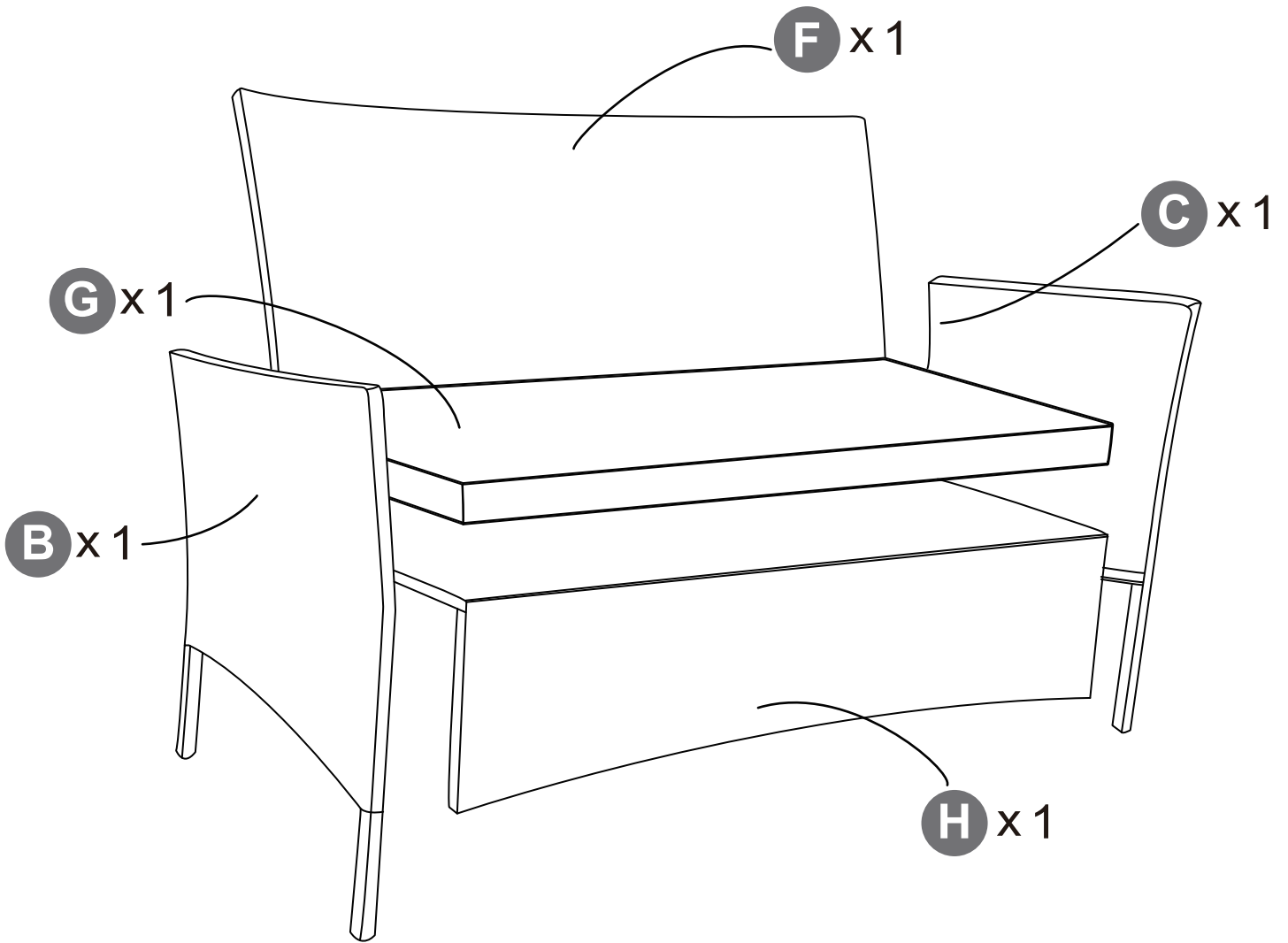

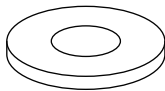
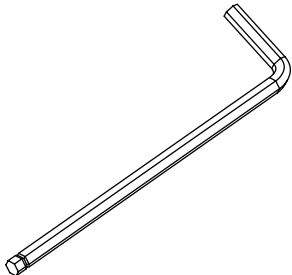
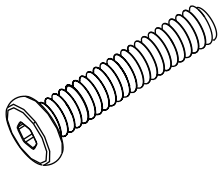
<p>2</p>  <p>x 12</p>	<p>3</p>  <p>x 1</p>	<p>4</p>  <p>M6*35MM</p> <p>x 12</p>
---	--	--

PART LIST

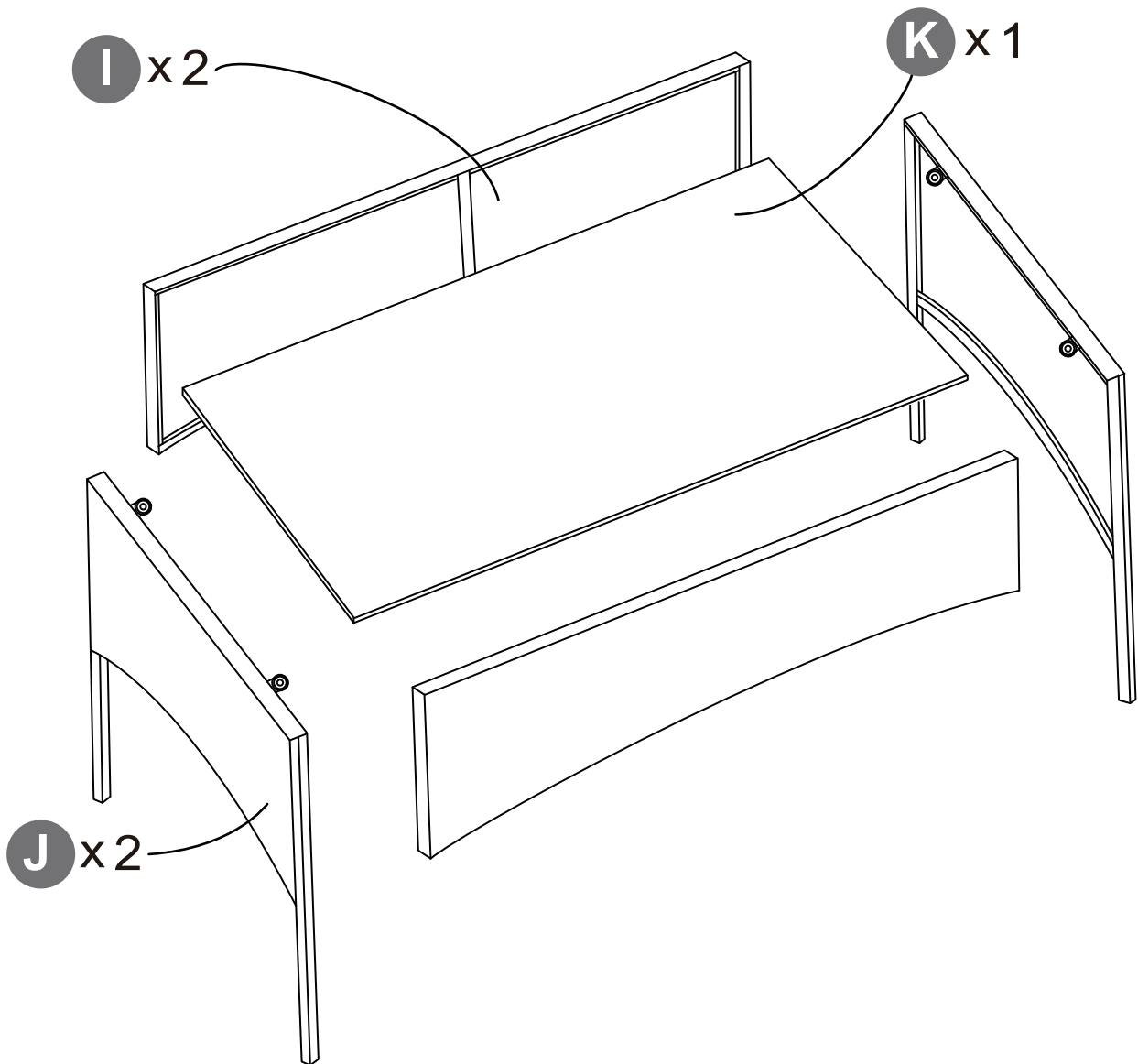

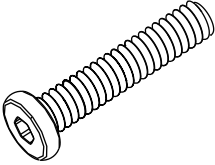
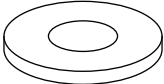
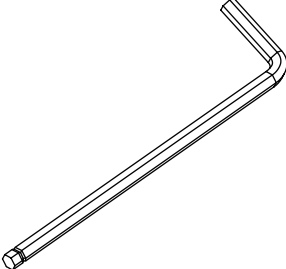
<p>1</p>  <p>M6*30MM</p> <p>x 8</p>	<p>2</p>  <p>x 8</p>	<p>3</p>  <p>x 1</p>
---	--	--

STEP

1

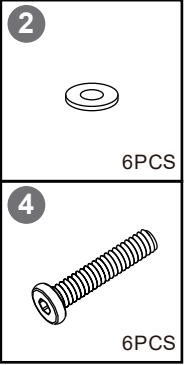
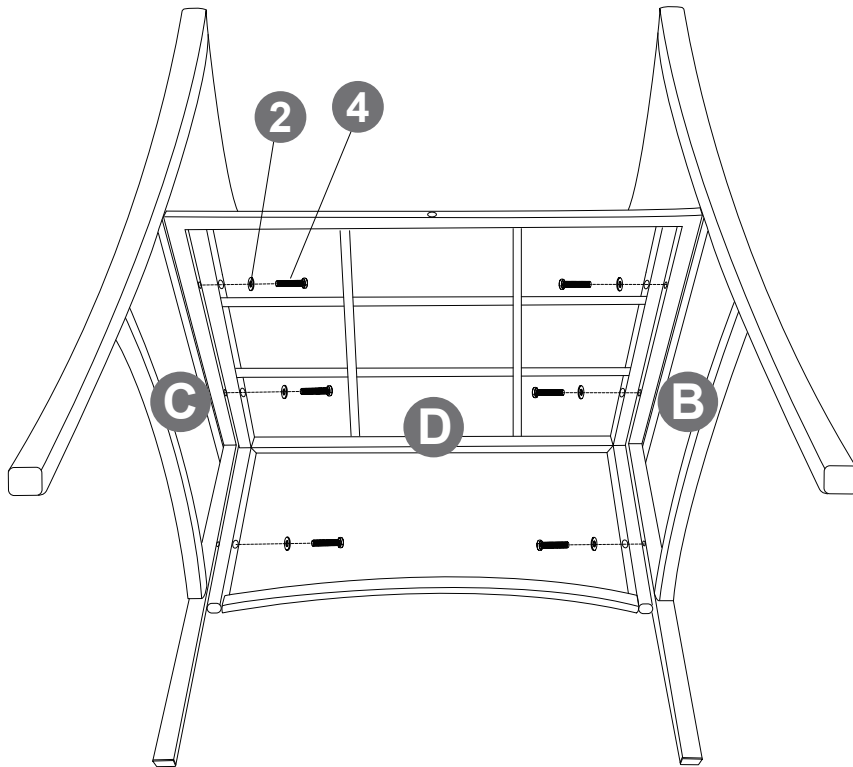

2

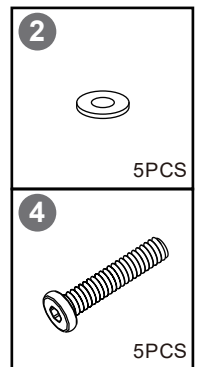
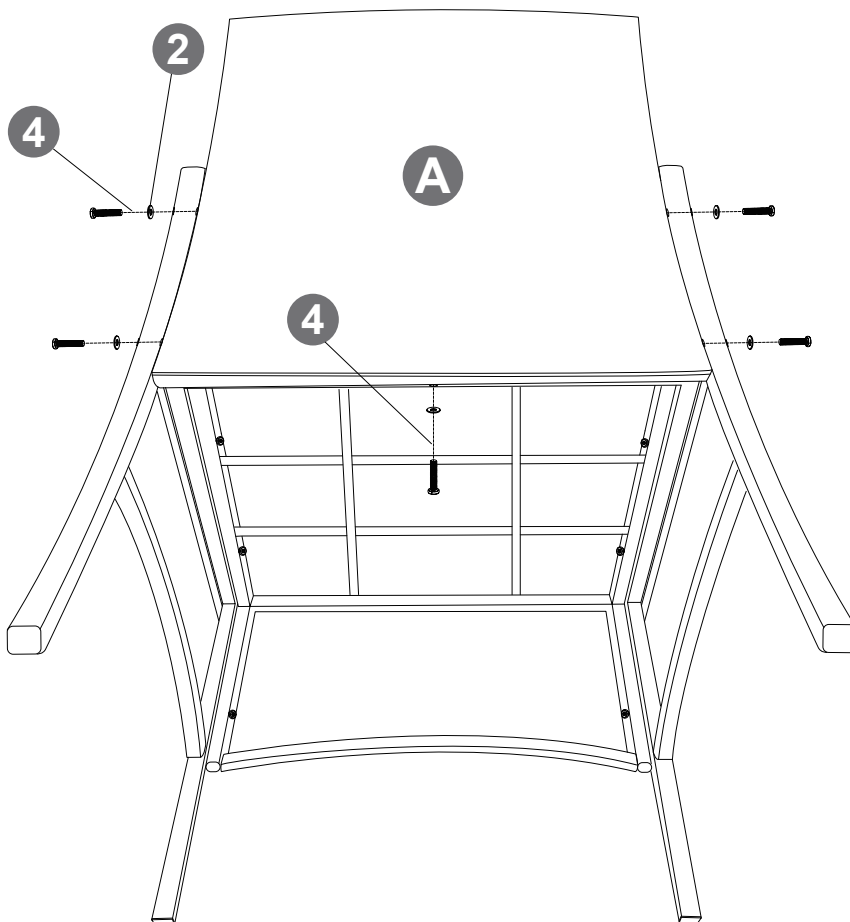

5

STEP

3

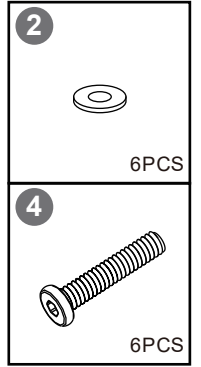
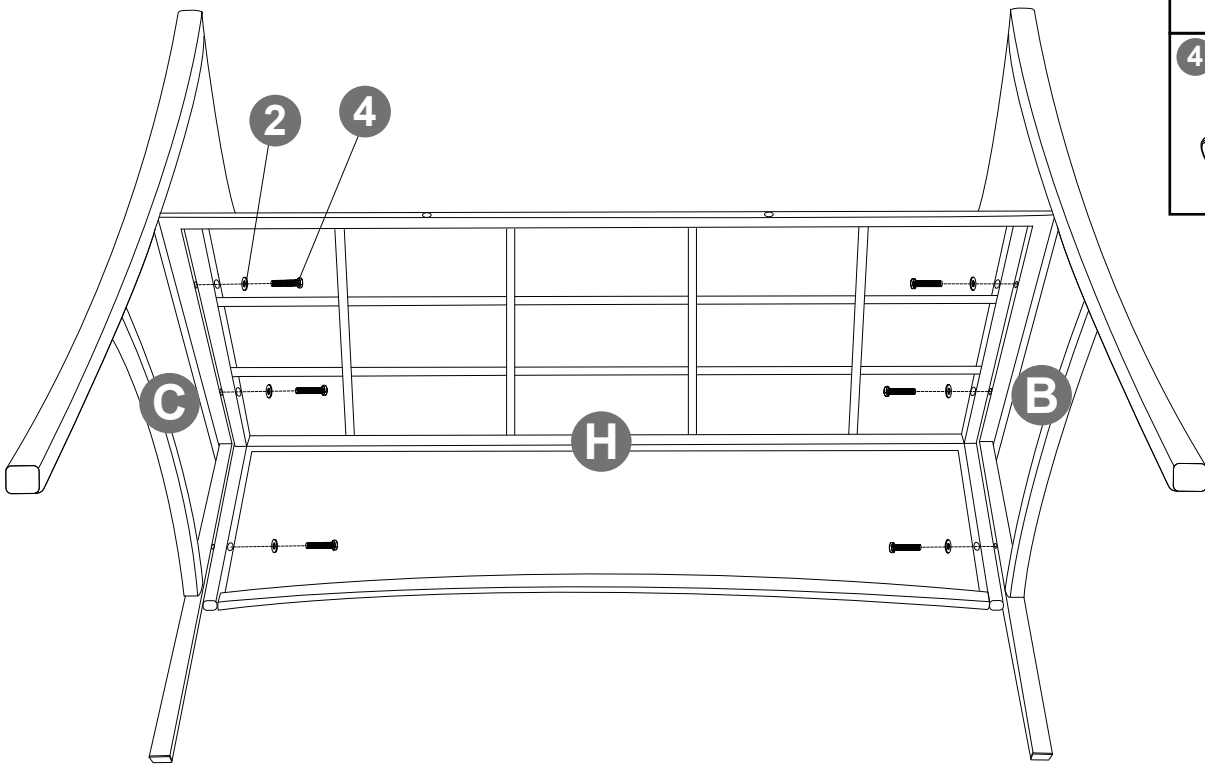

4

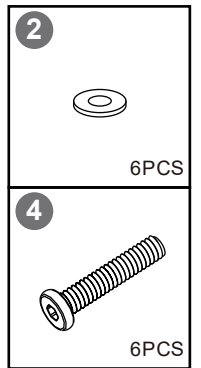
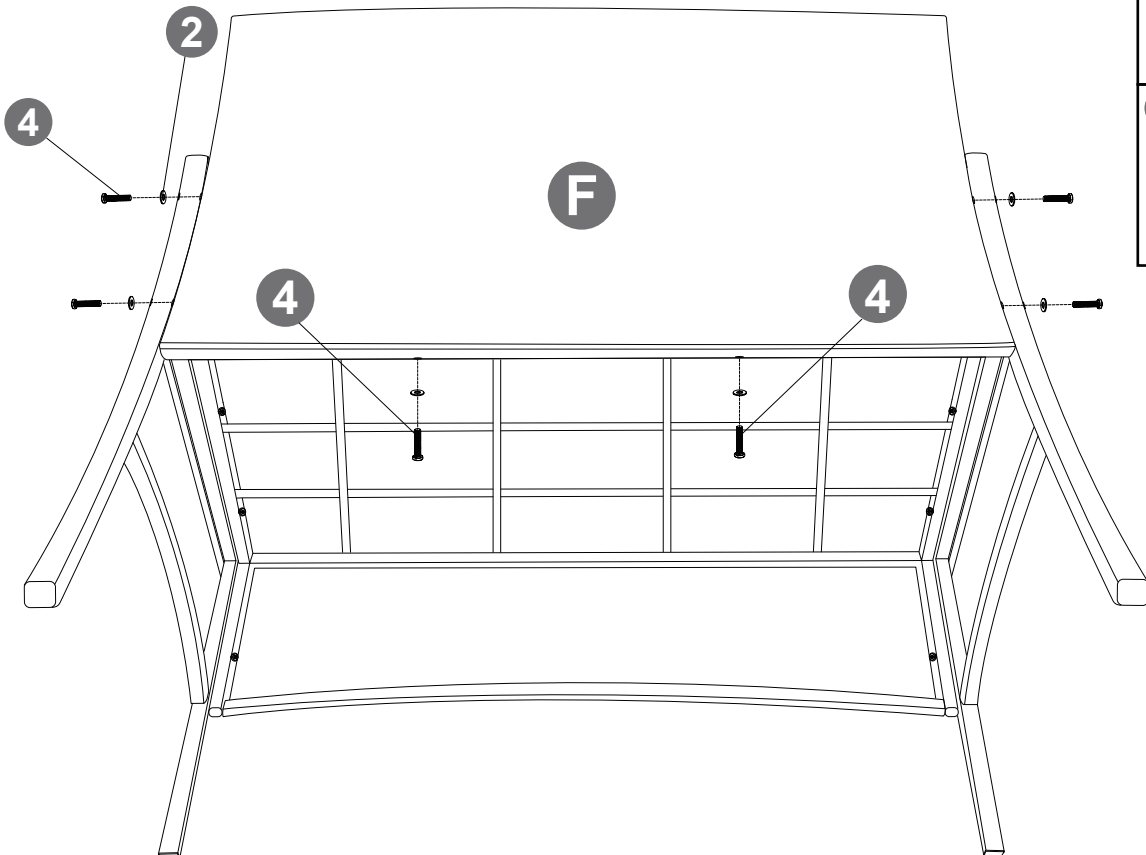

6

STEP

5

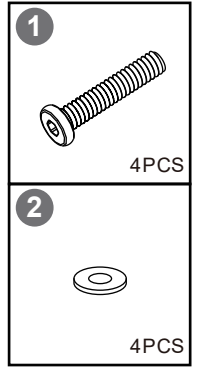
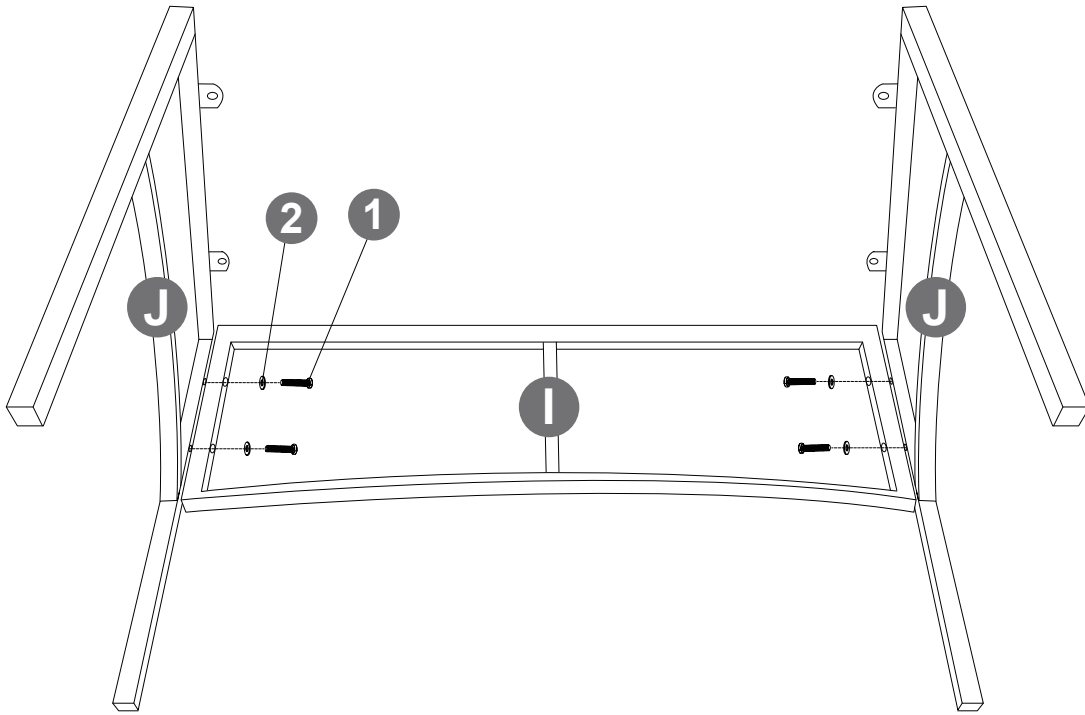

6

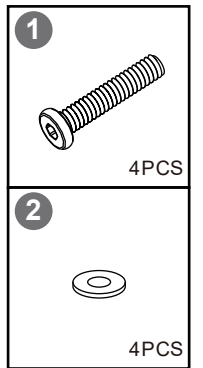
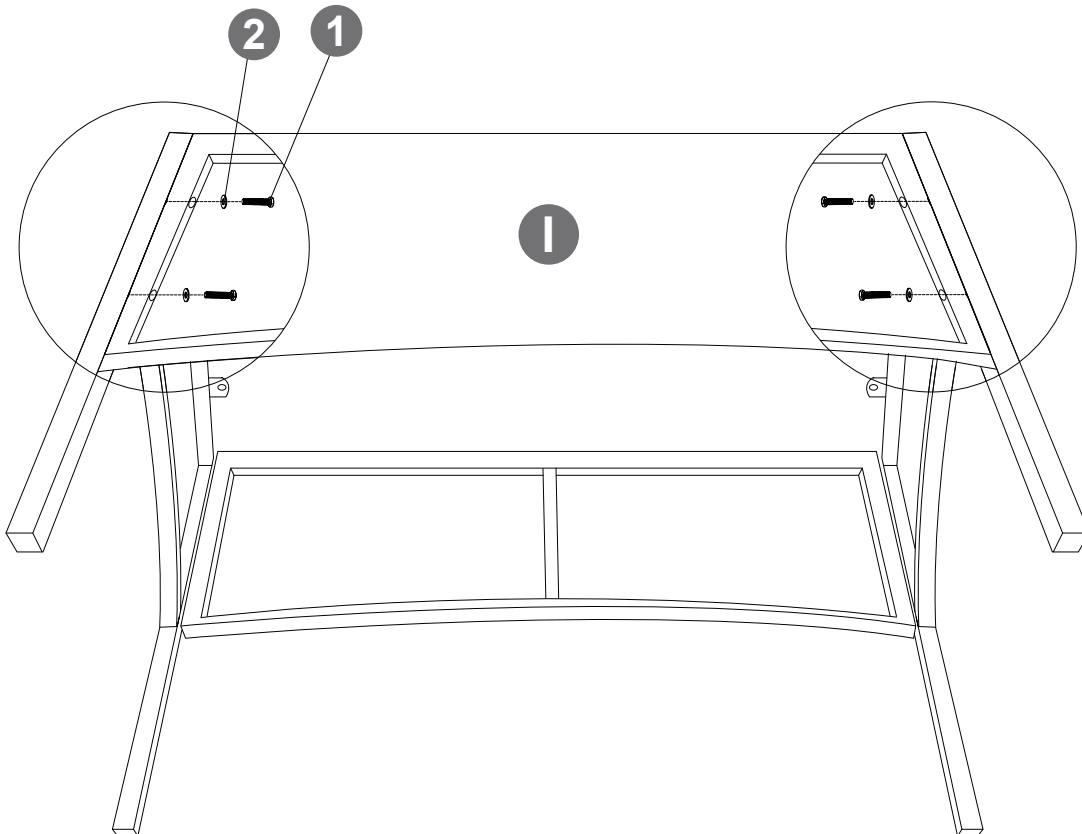

STEP

7

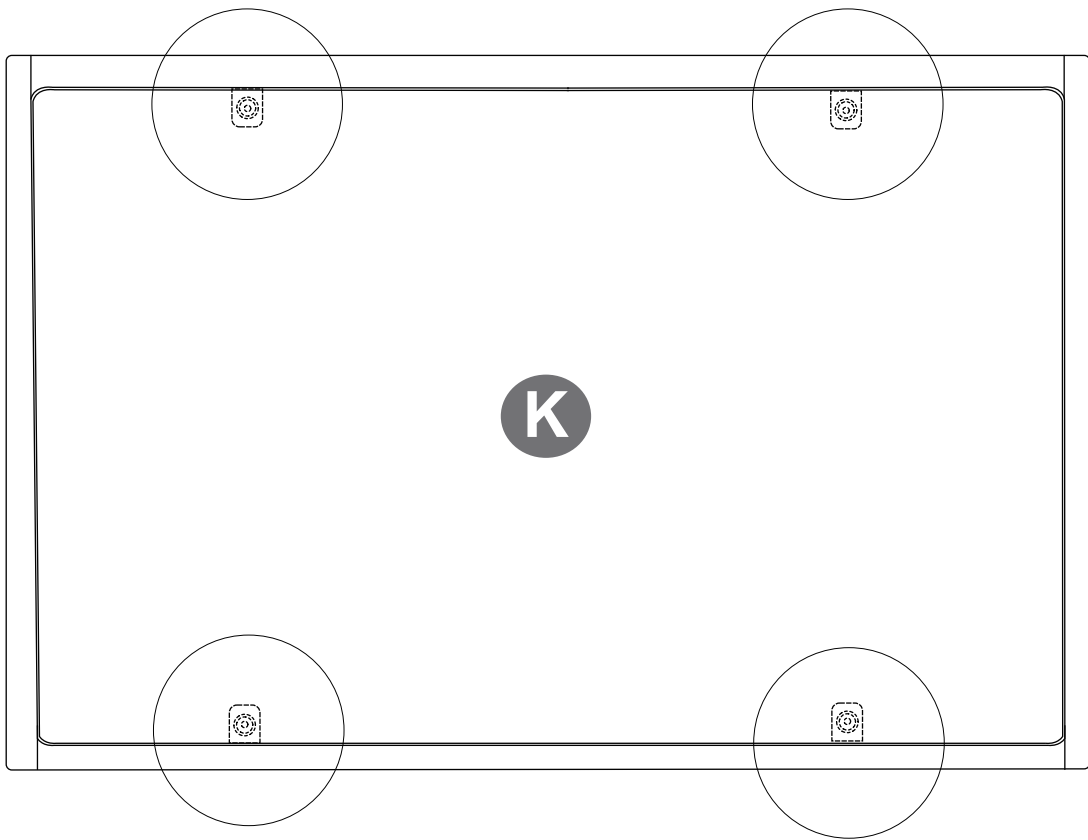

STEP

8

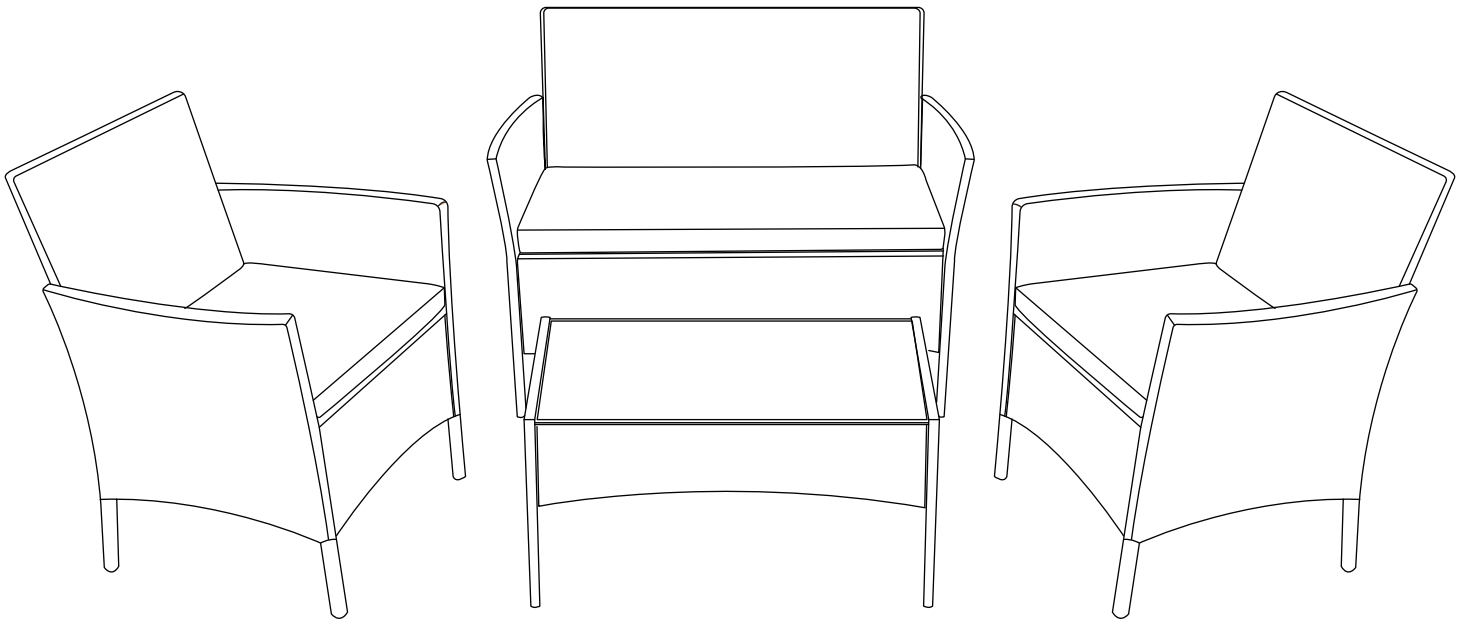

AFTER-SALE SERVICE

If you have any suggestions for our products or find that the products have quality problems, please contact us first, our after-sales team will reply you within 24 hours, and we will do our best to give you solutions until you are satisfied.

Guaranteed Customer Service

Your shopping experience is very important to us!
Feel unsatisfied? **Contact us!**
Have any questions? **Contact us!**

Wanna Share how wonderful our smart promakes your home?
Share your pictures with us.
Any suggestions? **Contact us!**
We gotcha back!



Patiofurniture Serviceteam@outlook.com

