

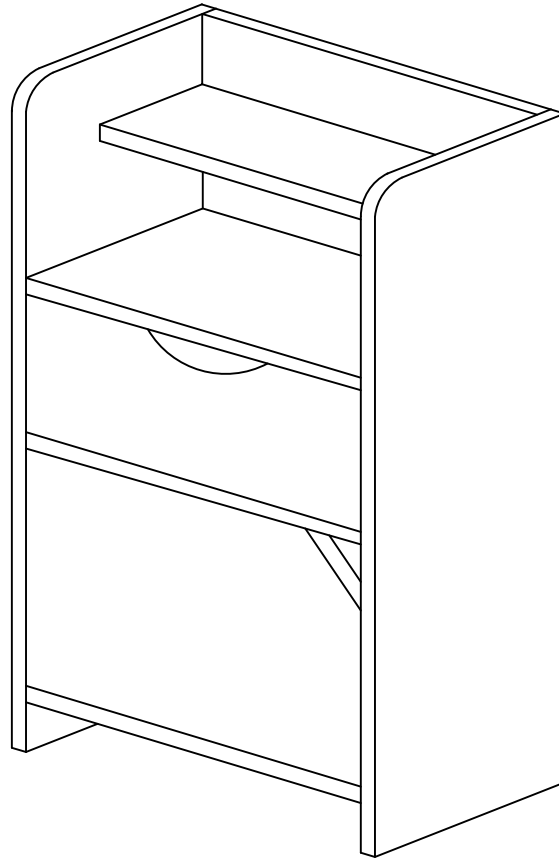

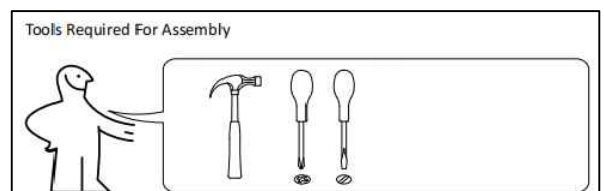

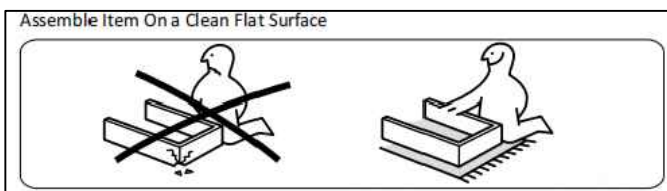

Instruction Manual



DEAR CUSTOMER,
Thank you for choosing our product. Please read this manual carefully before assembling. If the product is passed on to the third party, this manual has to be passed on along with the product. Enjoy your new purchase!









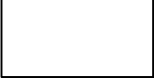

HARDWARE LIST

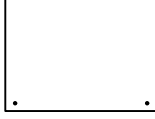
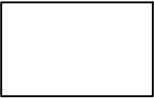
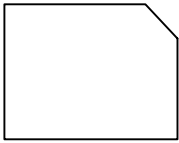
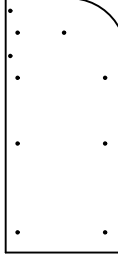
| | | | | |
|---|---|--|---|--|
| 1  ×8pcs | 2  ×8pcs | 3  ×20pcs | 4  ×3pcs | 5  ×n pcs |
|---|---|--|---|--|

PARTS LIST

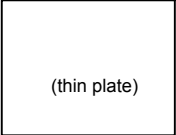
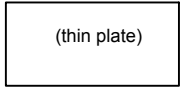

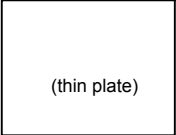
Note: there will be some error in the measurement, the actual size shall prevail.

| | | | |
|---|---|--|---|
| A  ×1pc | B  ×1pc | C  ×1pc | D  ×1pc |
| E  ×1pc | F  ×1pc | G  ×2pcs | H  ×1pc |
| I  (Left) ×1pc | K  ×1pc | M  (thin plate) ×1pc | N  (thin plate) ×1pc |
| J  (Right) ×1pc | L  (thin plate) ×1pc | | M  (thin plate) ×1pc |

NOTE

- Please check that you have all the parts and hardware listed before assembling.
- Please do not tighten all bolts until the table is assembled completely.
- If you find that something is missing, please contact the store you purchase immediately.
- At least every 4 months, check all bolts, screws and knobs to be sure they are tight.

Screws Installation Steps

| | |
|--|---|
| 1  ×8pcs | 2  ×8pcs |
|--|---|

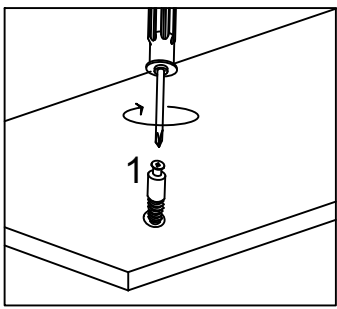

Screw the eccentric screw onto the board.

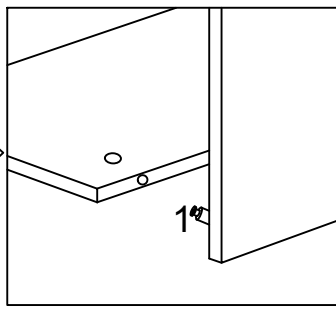

Find the corresponding board to insert.

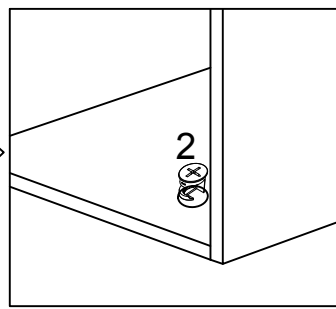

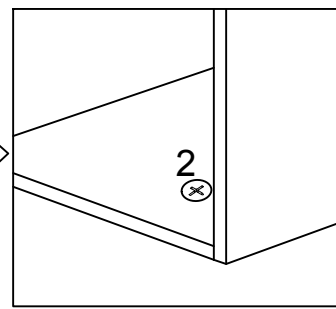

Insert eccentric bolt into round hole.



Turn clockwise about 180° to lock the board.

Step:1 (Installing drawer)

| | |
|---|---|
| 1  ×8pcs | 2  ×8pcs |
|---|---|

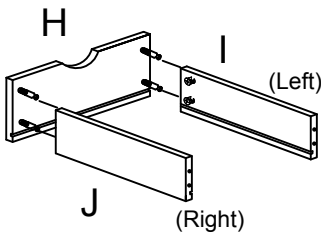

Connect left and right side panels to drawer panels.

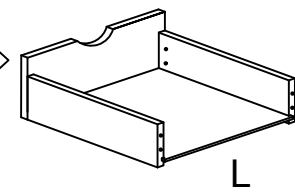

Install drawer bottom plates.

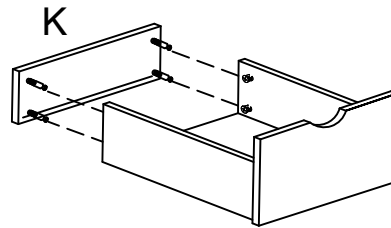

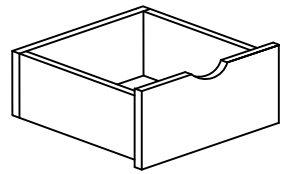

Install drawer back plates.



Installation Complete !

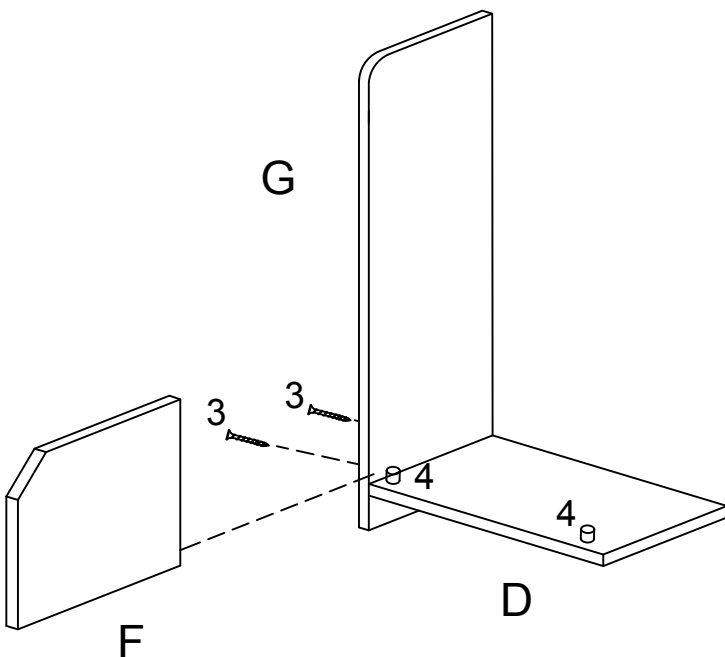

Step:2

| | |
|--|---|
| 3  ×20pcs | 4  ×3pcs |
|--|---|



Install panel through fitting 3 and 4.

Step:3

| | |
|--|---|
| 3  ×20pcs | 4  ×3pcs |
|--|---|

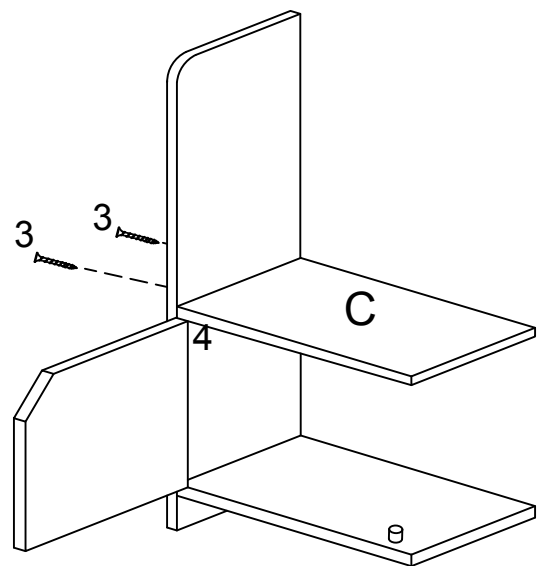

Install panel through fitting 3 and 4.

Step:4

3
↓
x20pcs

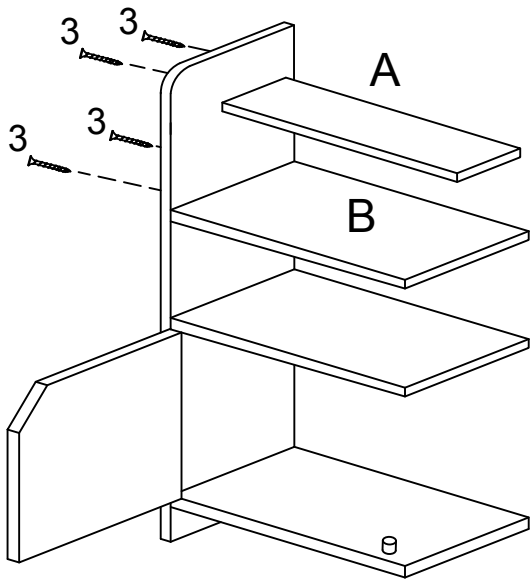

Install panel A and B through fitting 3.

Step:5

3
↓
x20pcs

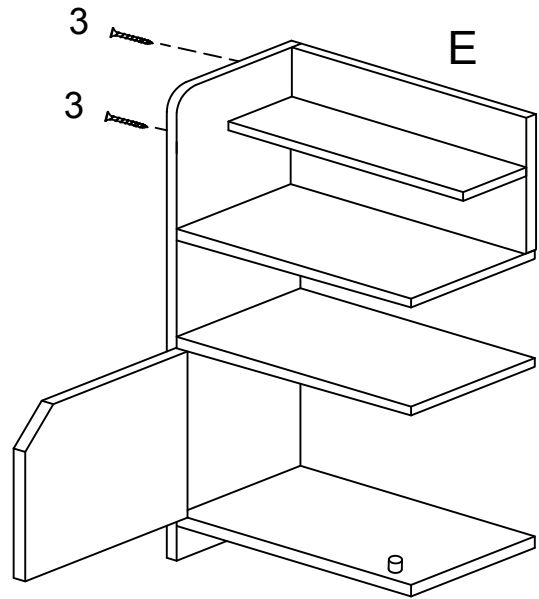

Install panel E through fitting 3.

Step:6

3
↓
x20pcs

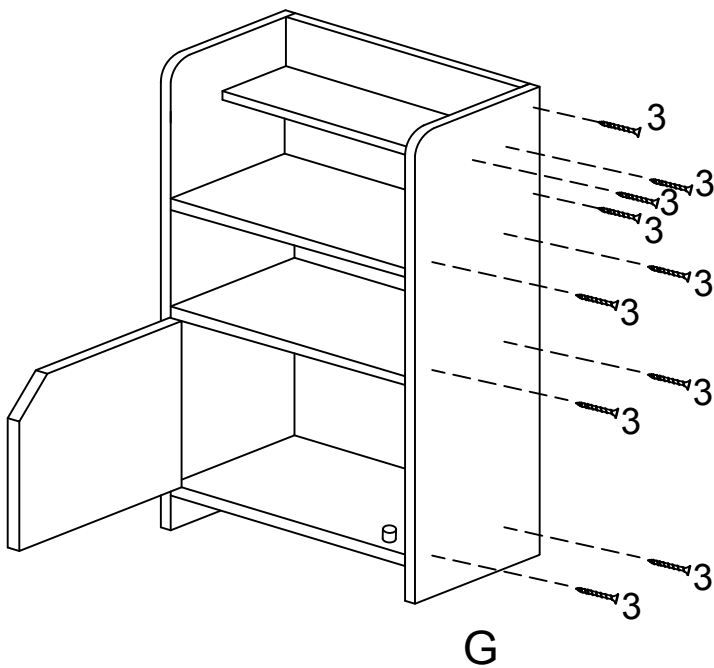

Install panel G through fitting 3.

Step:7

5
↓
x n pcs

Installation Complete !

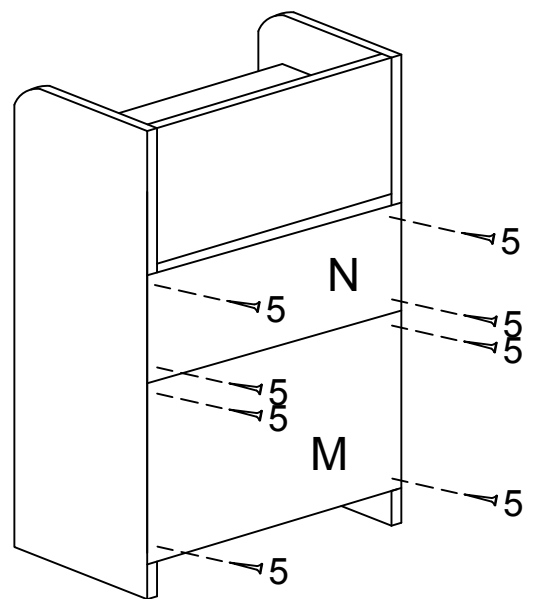

Install panel M and N through fitting 5.