

## ASSEMBLY INSTRUCTION DINING BENCH







### IMPORTANT SAFETY CONSTRUCTION

Thank you for purchasing this quality product. Be sure to check all packing material carefully for small parts that may have come loose inside the carton during shipment. Please read all instruction carefully before assembling. For your safety, assembly by two people is recommended.

### PARTS INCLUDED:

- (1) Bench Seat (a)
- (2) Left Legs (b)
- (2) Right Legs (c)
- (2) Middle Legs (d)
- (3) Short Stretcher (e)
- (4) Long Stretcher (f)

### HARDWARE ENCLOSED:

- A 8x  Ø8
- B 4x  Ø6 x 40mm
- C 12x  Ø8 x 13mm
- D 12x  Ø8 x 19mm
- E 1x 
- F 1x 
- G 14x  Ø4 x 38mm

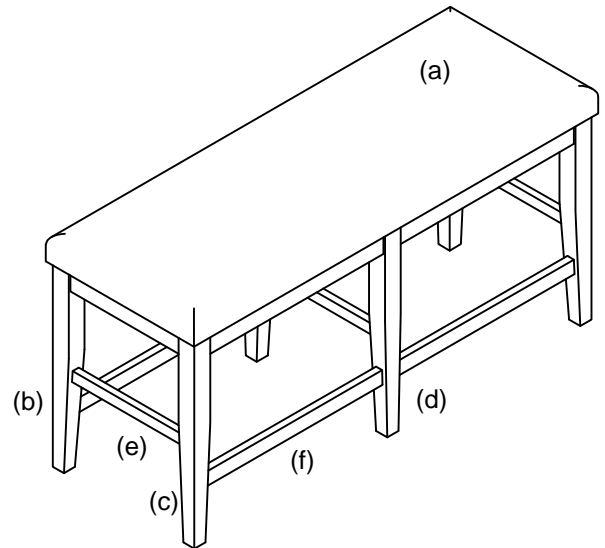

### ASSEMBLY INSTRUCTIONS

#### STEP 1

- Carefully lay Bench Seat upside down on a smooth flat surface to prevent scratches.
- Affix each Leg to each corner of the Bench Seat as shown in illustration.
- Insert Nut (A) with Flat washer (D), Lock washer (C) through holes in wooded corner.(See Detail A)
- Affix Middle Legs to between of the Bench Seat as shown in illustration.
- Insert Bolt (B) with Flat washer (D), Lock washer (C) through holes in wooded.(See Detail B)
- Once all Legs are in place, fully tighten Nut by turning clockwise using Wrench until secure.

#### DETAIL A

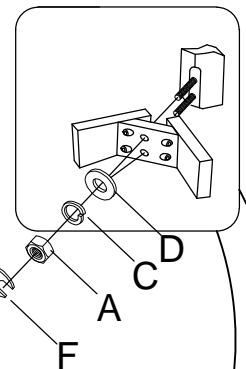

#### DETAIL C

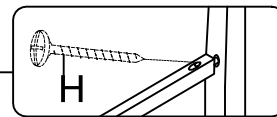

#### DETAIL B

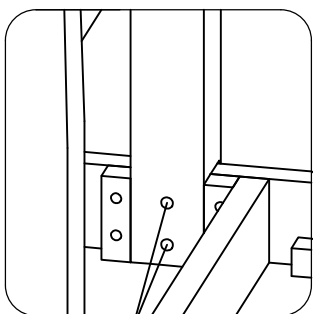

#### STEP 2

- Insert 3 Short Stretchers and 4 Long Stretcher between the corner legs and middle legs; fasten with Wood Screw using phillip-head screwdriver (not provided).(See Detail C)
- Be sure to level the chair prior to tightening all the screws.

#### NOTES:

The use of power tools for assembly is not recommended. Power tools can damage hardware or split wood.