

6 Drawer Dresser Installation Instructions

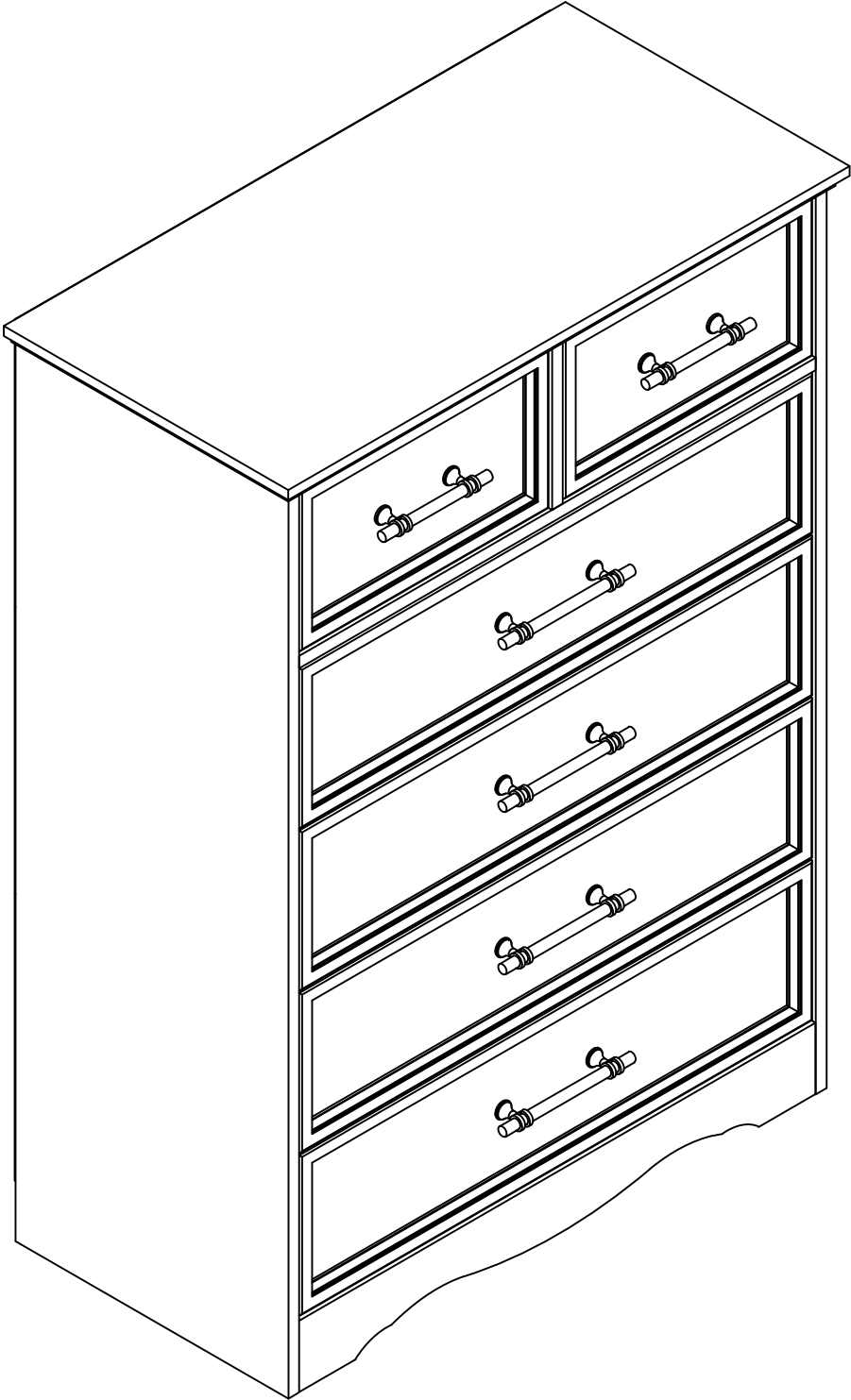

PACKAGE INCLUDE

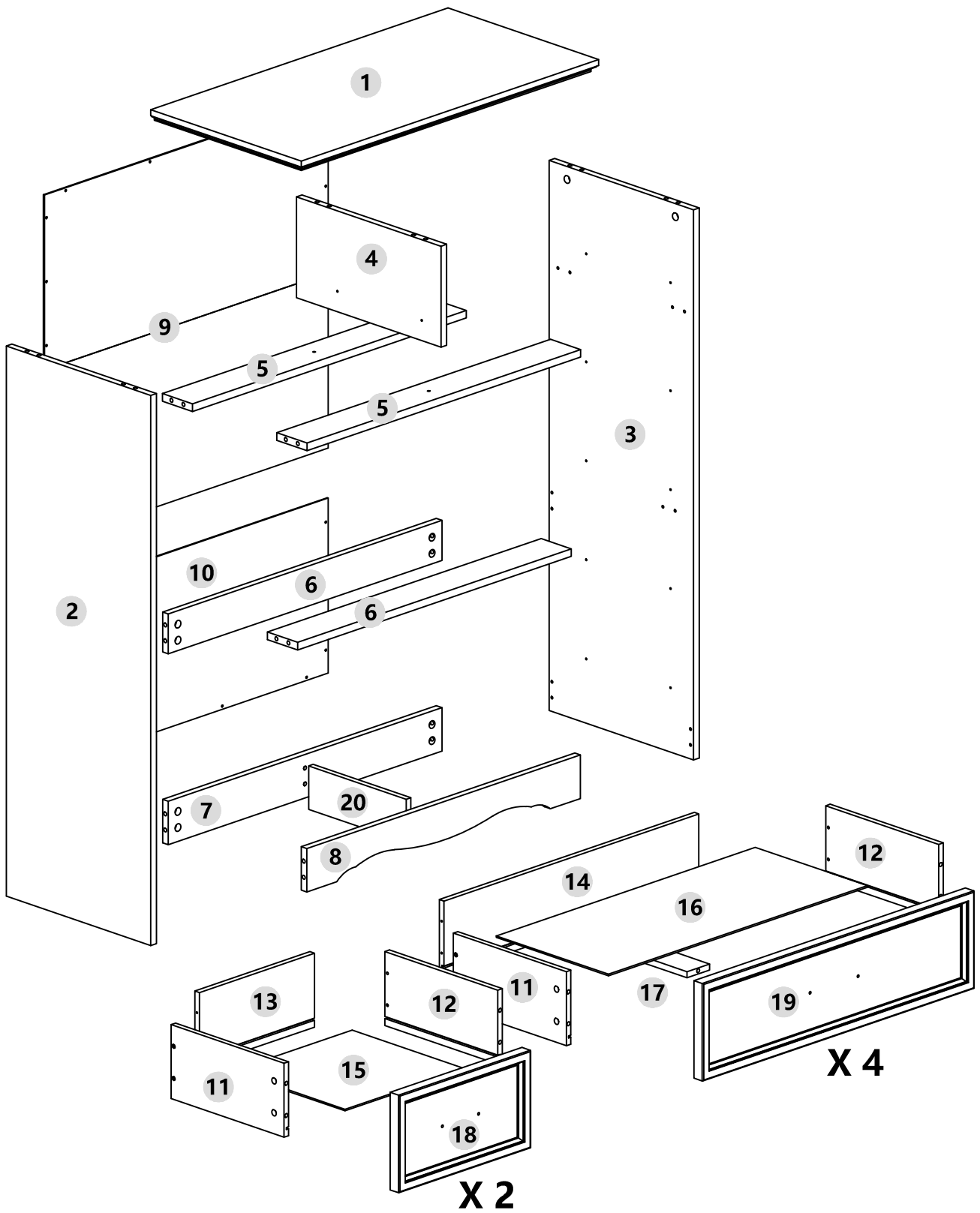







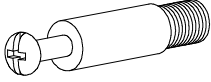

KEEP THE NUMBER STICKERS ON panel UNTIL FINISHED ASSEMBLING!

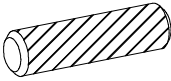
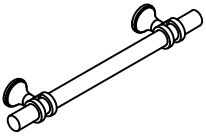

PART IDENTIFICATION

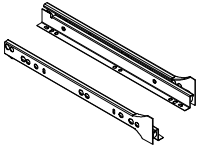
CODE	DESCRIPTION	QTY
1	Top panel	1
2	Left side panel	1
3	Right side panel	1
4	Upper middle partition panel	1
5	Upper drawbar	2
6	Lower drawbar	2
7	Back bottom panel	1
8	Front bottom panel	1
9	Top back panel	1
10	Bottom back panel	1
11	Drawer left side panel	6
12	Drawer Right side panel	6
13	Short Drawer tail plate	2
14	Long Drawer tail plate	4
15	Bottom panel of drawer	2
16	Bottom panel of drawer	4
17	Bottom drawbar of drawer	4
18	front panel of upper drawer	2
19	front panel of Lower drawer	4
20	middle bottom panel	1

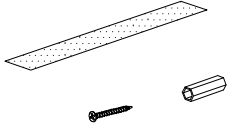
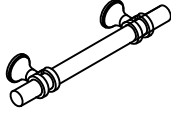
PACKAGE CONTENTS

<p>M6x34MM</p>  <p>A 61x+2</p>	<p>Ø15x9MM</p>  <p>B 61x+2</p>	<p>Ø8x30MM</p>  <p>C 6x</p>	<p>128MM</p>  <p>D 4x</p>
<p>Ø3.5x35MM</p>  <p>E 32x+1</p>	<p>Ø3.5x12MM</p>  <p>F 72x+2</p>	<p>Ø3.5x14MM</p>  <p>G 30x+2</p>	<p>12"</p>  <p>H 6x</p>
<p>Ø4x18MM</p>  <p>I 12x</p>	 <p>J 2x</p>	<p>96MM</p>  <p>K 2x</p>	<p>Ø4x38MM</p>  <p>L 2x</p>

How do we finish the installation of the cam lock system?

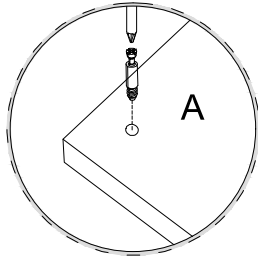

1. Screw a cam bolt A into the panel

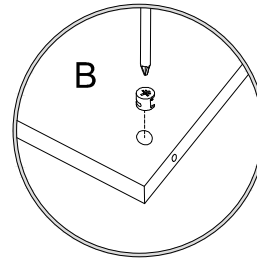

2. Push a cam B into the panel, make sure the arrow feature on the cam B points to the panel edge

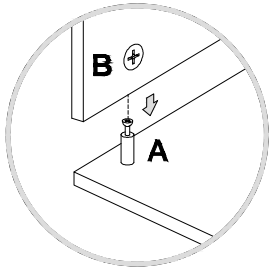

3. Align cam bolt(s) A with cam(s) B and then insert cam bolt(s) A into cross-bored hole(s) completely

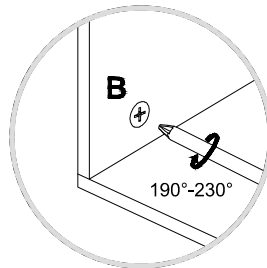

4. Rotate cam(s) B clockwise 190°-230° to lock 2 panels together

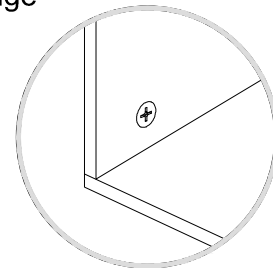

5. 2 panels should be tight against with each other and the connection should be rigid

Insert the wood dowel [C] at least half way by tapping lightly with a rubber mallet, IF NECESSARY.

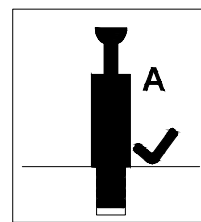
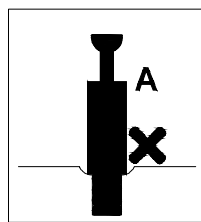
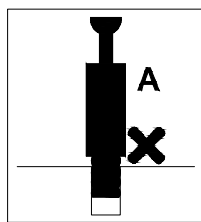
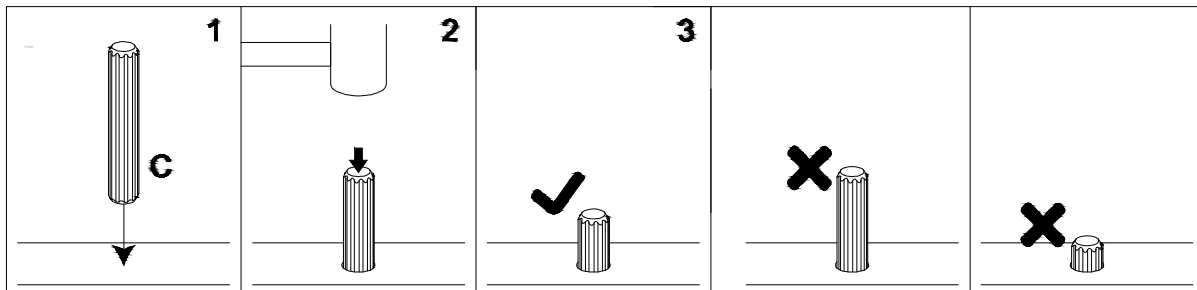

⚠ WARNING

- Unit must be placed on a level surface or leveled with included hardware (when applicable).
- Do not sit or stand on or allow children to climb, sit or stand on the assembled product.
- For safety reasons, it is imperative that this unit be mounted to the wall.
- Do not use without installing the tip restraint.
- Unit can tip over causing severe injury or death.
- Do not exceed the recommended weight limits.
- Evenly distribute the weight on each level and always keep the heavier loads on the bottom.
- Before cutting, drilling or hammering into any wall or floor surface, verify the location of electrical, plumbing and gas lines. Cutting may cause serious injury.

Ready to assemble the dresser

Before installation, observe each structure of the drawer dresser. The drawer dresser consists of two main parts. You will assemble the chest first, and then install the three small drawers and four larger drawers. We should keep all track slides on the dresser body in one direction like the below finished look.

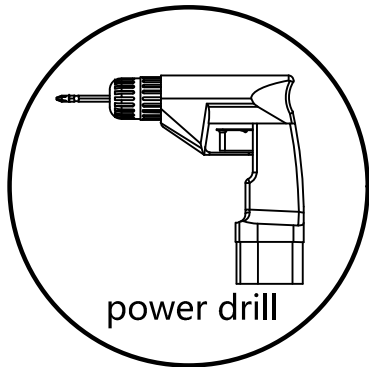

We recommend using a power drill to assemble.

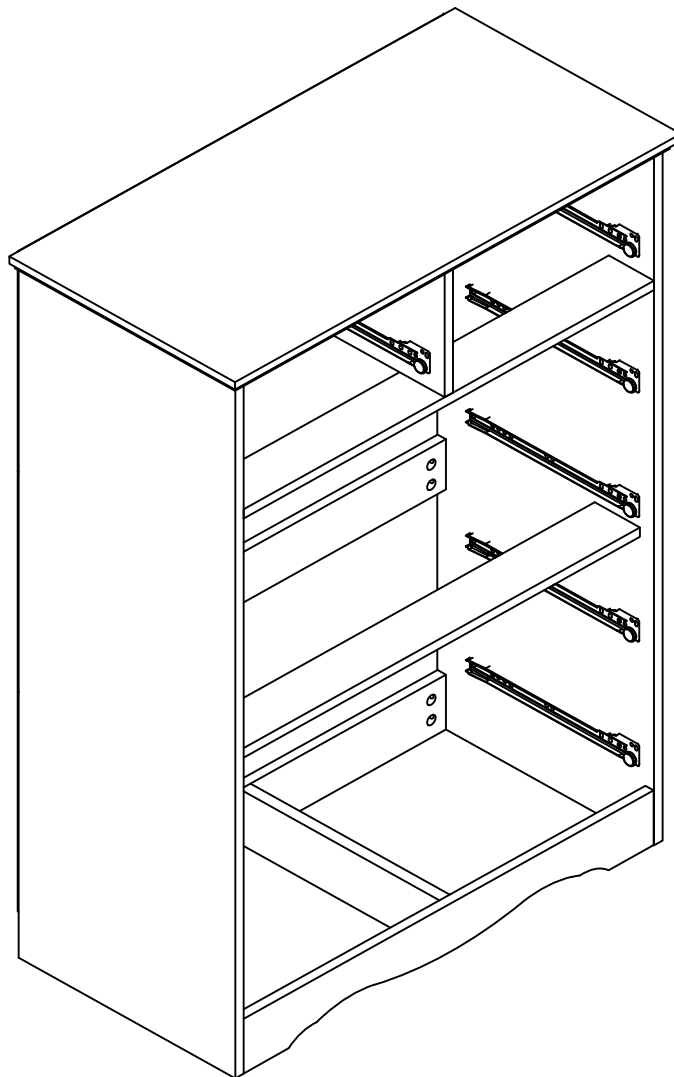

STEP 1-1

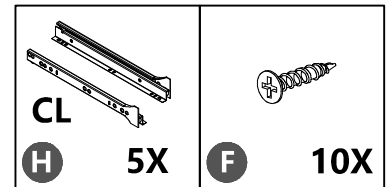

-Install the drawer slide (H) on the left side panel (2). The tracks are marked with the CL symbol. We have 6 X (H) and one lot (H) has a CL track.

Lot (H) has a CL track. So we need to open up 5 batches (H) to get 5 CL tracks.

-Tighten the track sliders with the screws (F) as shown below. Make sure the roller end of the track slider is facing up.

Make sure the 2 large pre-drilled holes are on the upside.

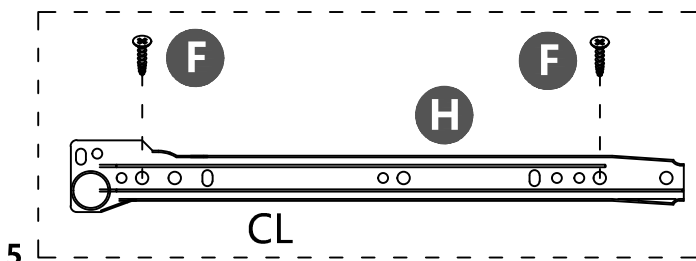

5

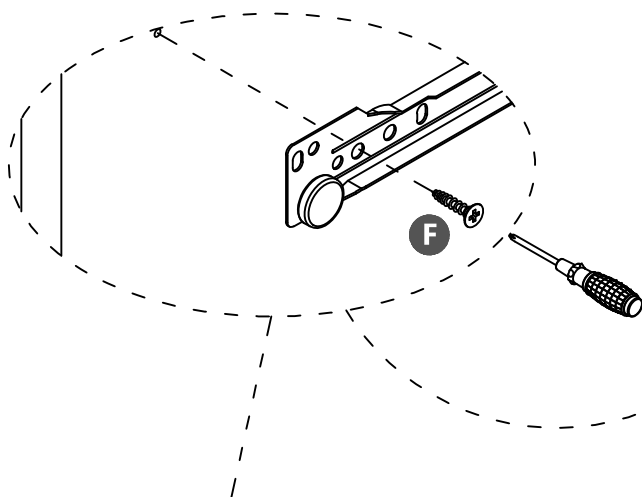

(F) should be locked in the second hole against the pulley

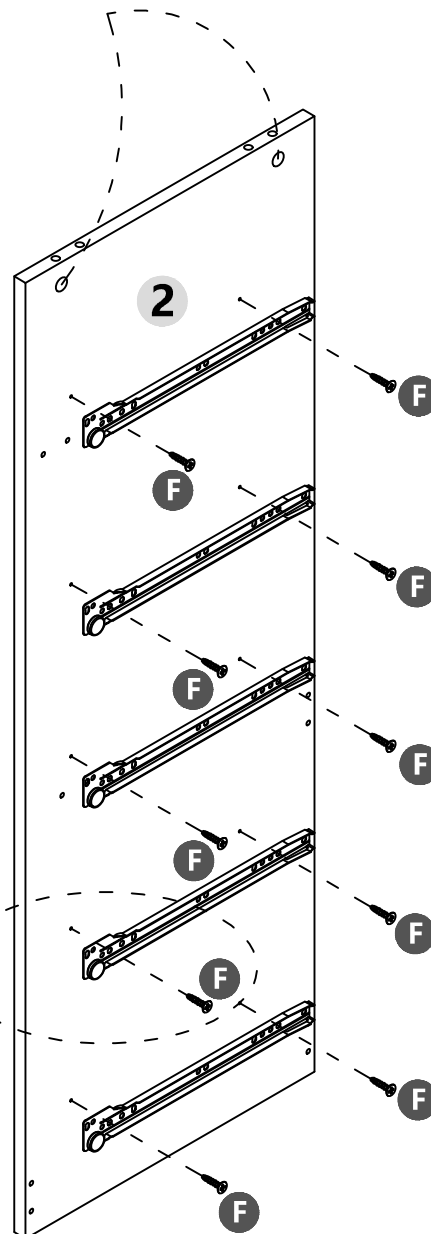

STEP 1-2

-Screw (F) to tighten the track slides as below shown.

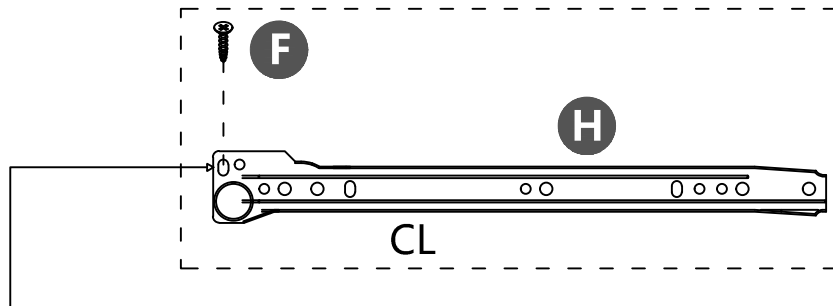
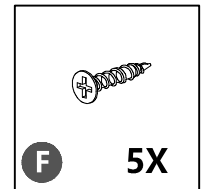

There are no pre-drilled holes corresponds to the upper row holes of the tightening. We need to confirm the position of the track slide, then screw the (F) on.

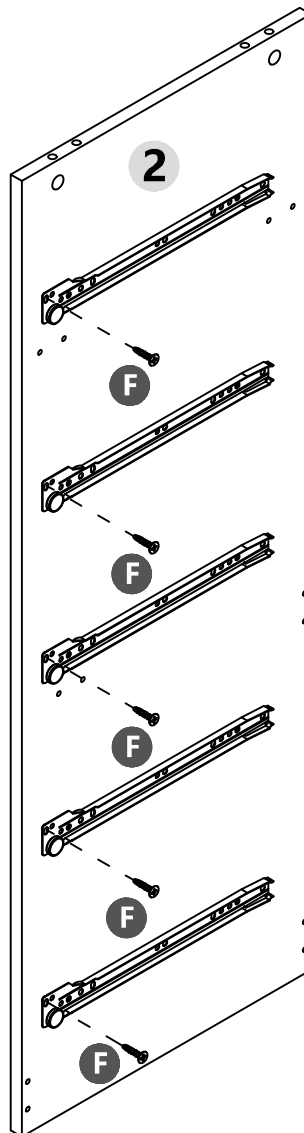

STEP 1-3

-Please refer the below look and check carefully after you assembled 5X CL track slides.

- Make sure you used 15 x (F).
- Make sure the end with roller of the track slides are in one direction.

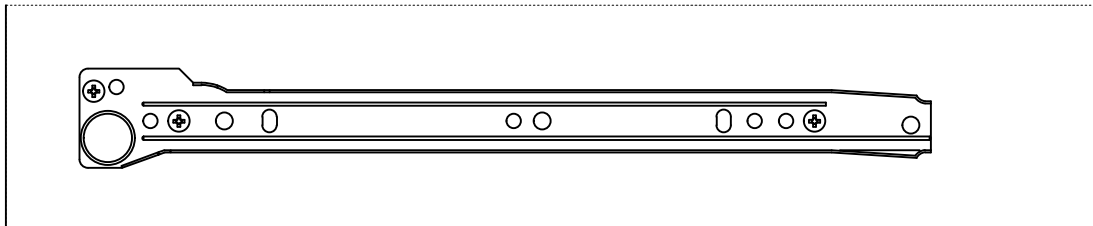

upper

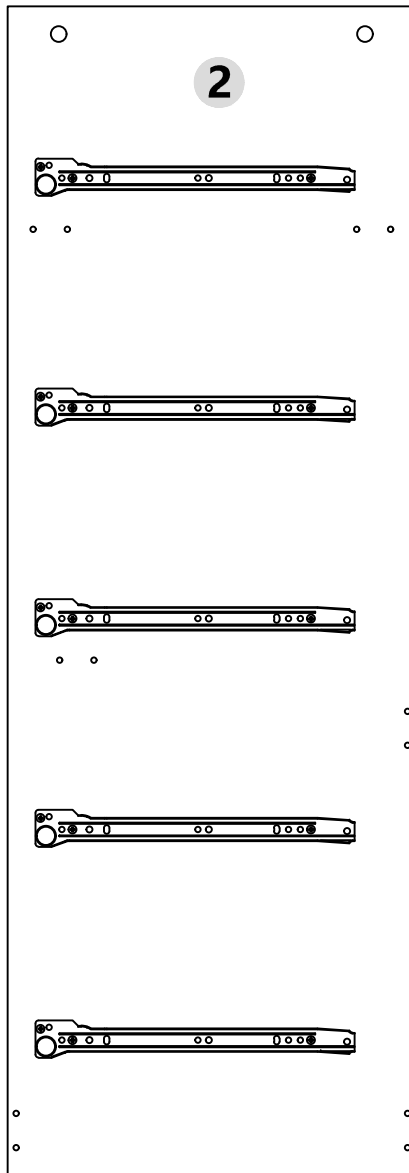

STEP 2-1

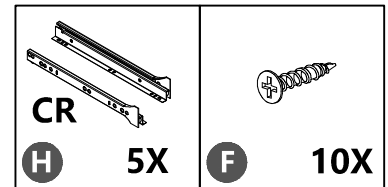

- Install the drawer slide (H) on the left side panel (3). The tracks are marked with the CR symbol. We have 6 X (H) and one lot (H) has a CR track.
- Lot (H) has a CR track. So we need to open up 5 batches (H) to get 5 CR tracks.
- Tighten the track sliders with the screws (F) as shown below.
- Make sure the roller end of the track slider is facing up.

Make sure the 2 large pre-drilled holes are on the upside.

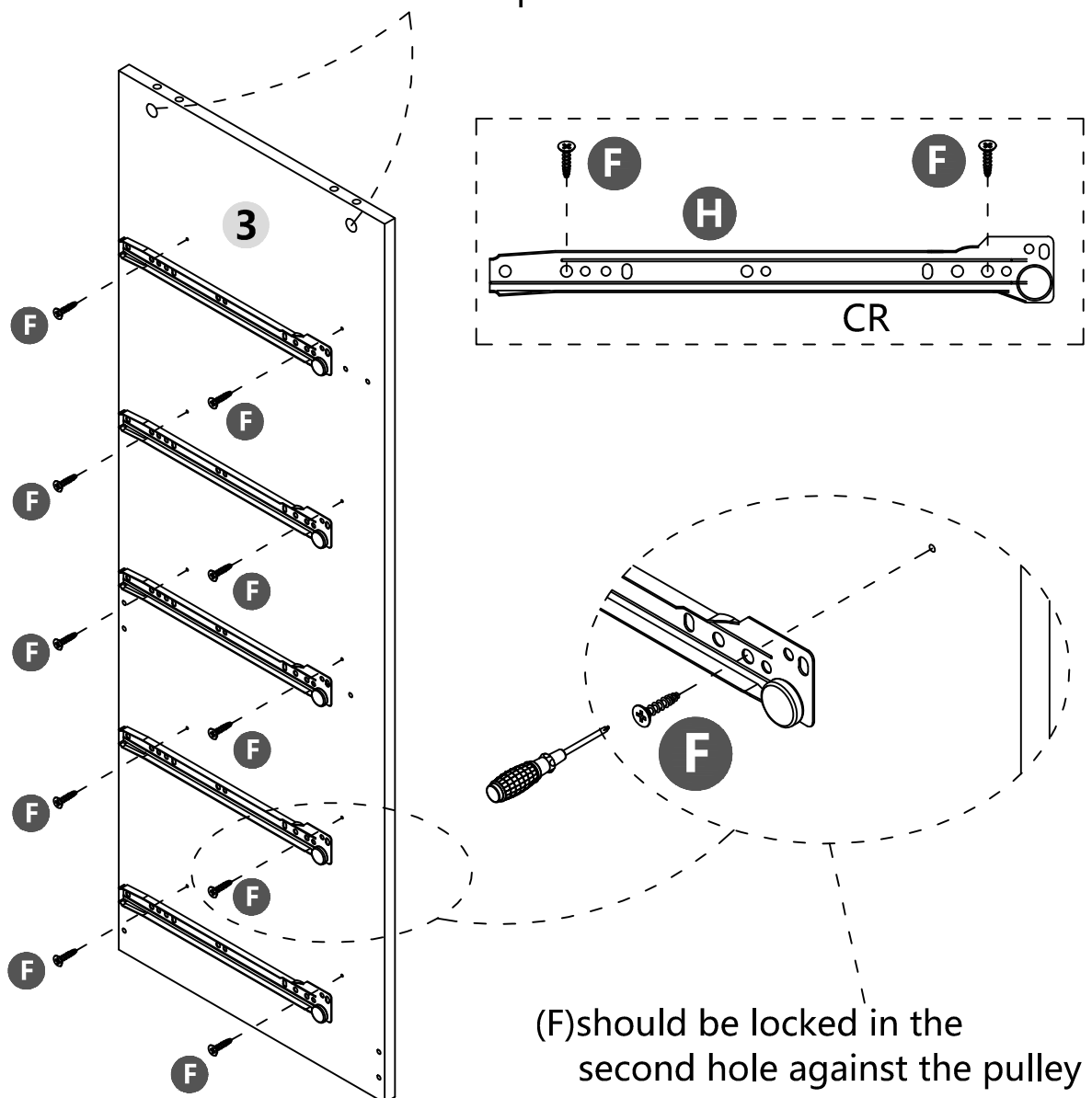

STEP 2-2

-Screw (F) to tighten the track slides as below shown.

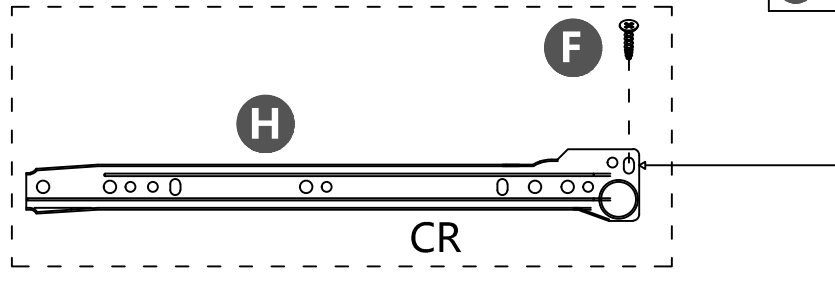
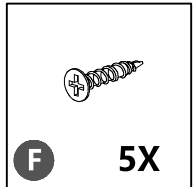

There are no pre-drilled holes corresponds to the upper row holes of the tightening. We need to confirm the position of the track slide, then screw the (F) on.

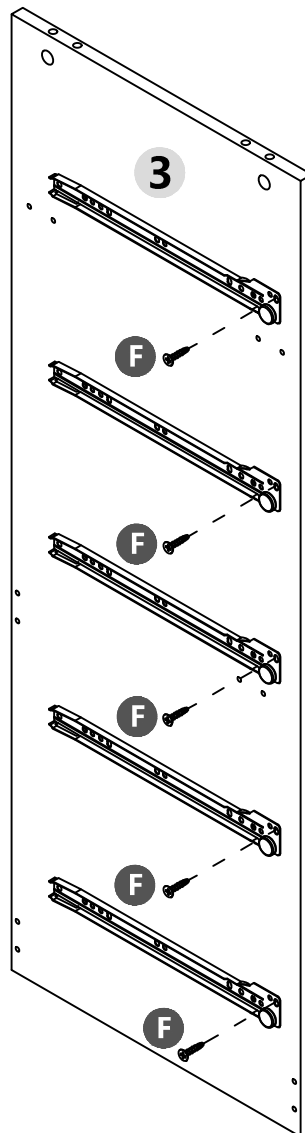

STEP 2-3

-Please refer the below look and check carefully after you assembled 5X CR track slides.

- Make sure you used 15 x (F).
- Make sure the end with roller of the track slides are in one direction.

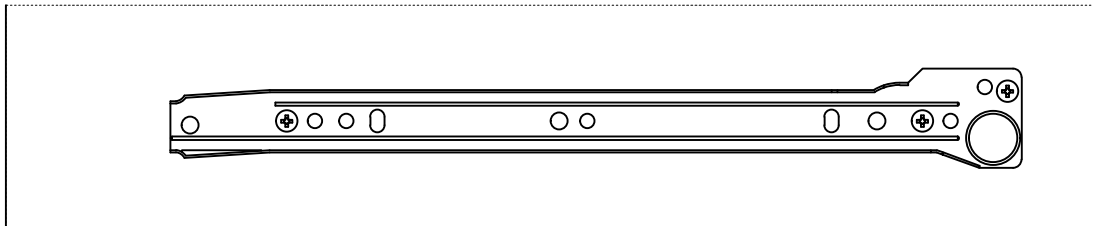

upper

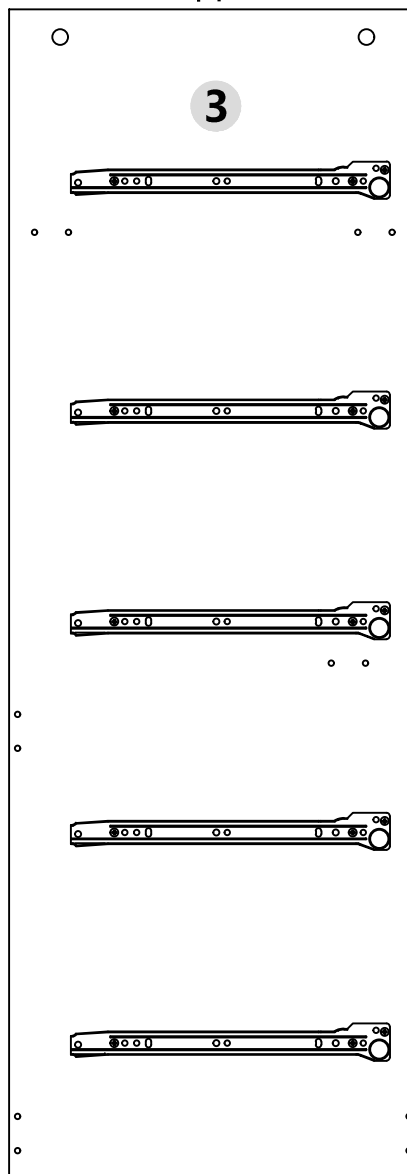

STEP 2-4

-Attach (A) to (3) as below shown

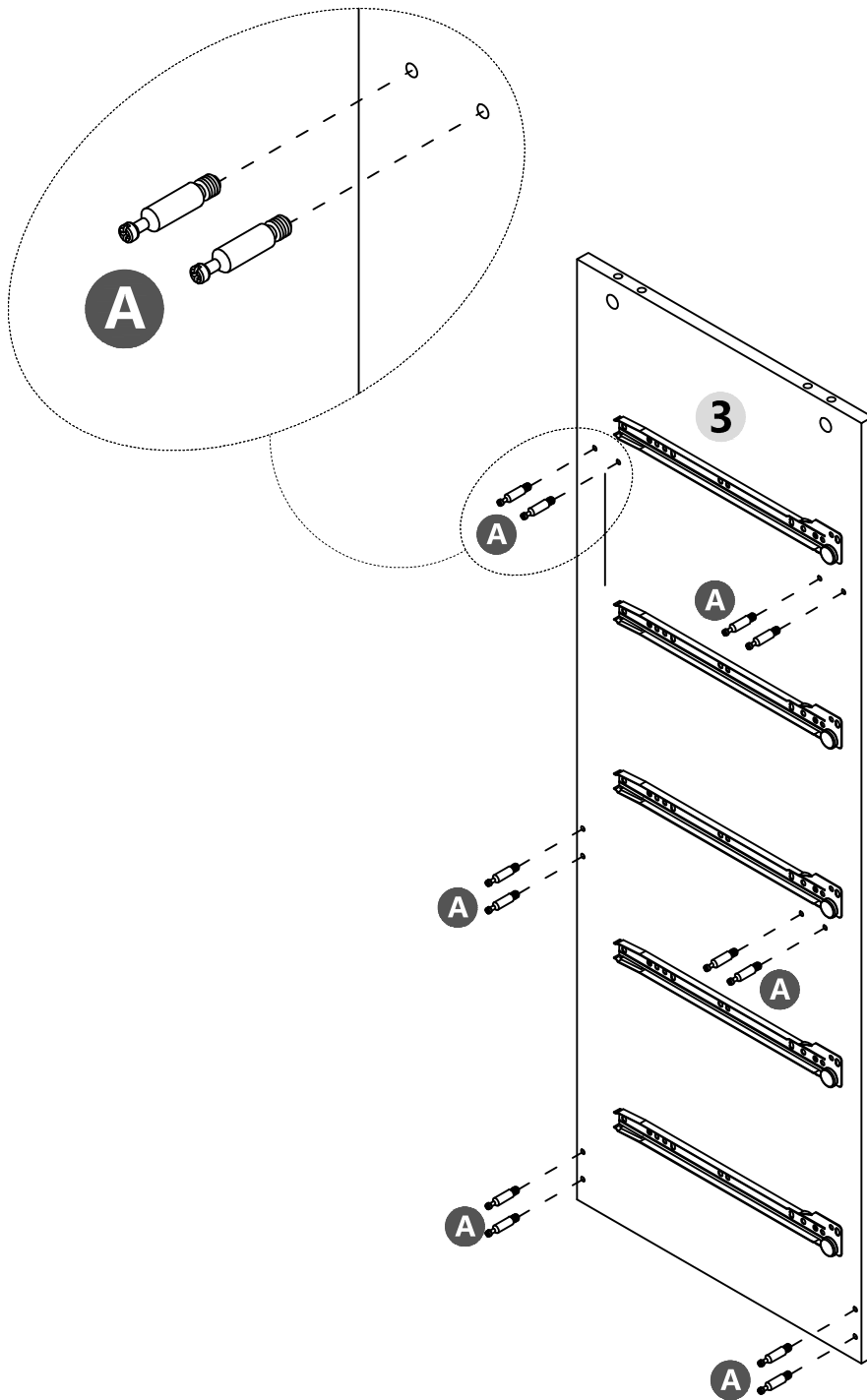
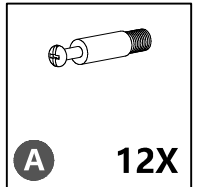

STEP 3

- The correct installation is shown in the picture below, please check it first before starting the installation.
- On one panel (4), make sure the end with roller of the 2 track slides are in one direction

CR track should be assembled on this side without holes of the panel (4)

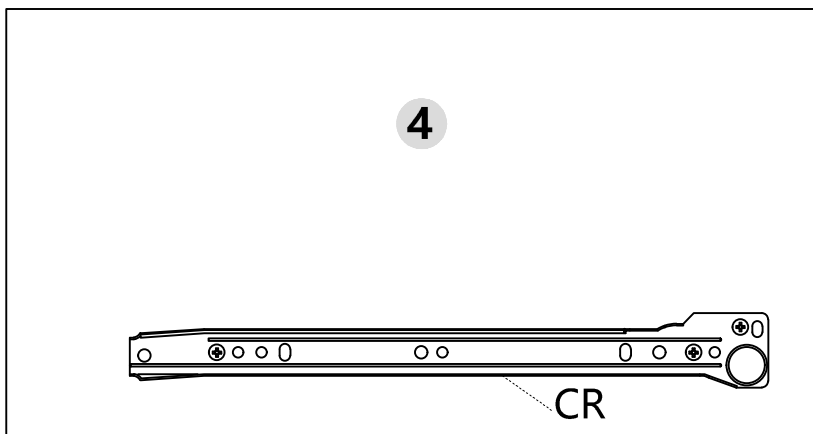

CL track should be assembled on this side with 2 big holes of the panel (4)

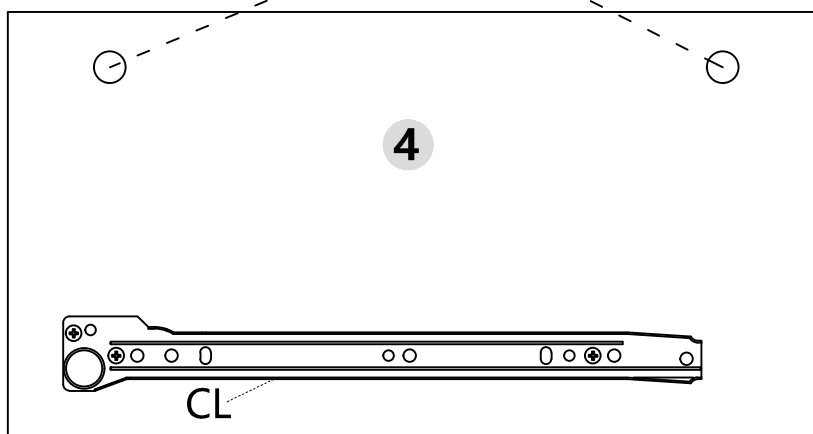

STEP 3-1

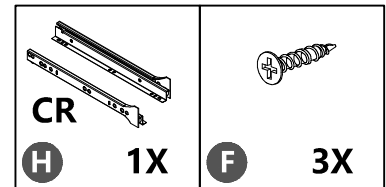

- Install the drawer slides(H) on the left side of upper middle partition panel(4).
- There is a CR sign on the track.Install CR track on the side without 2 big holes of panel (4)
- Screw(F)to tighten the track slides as below shown.

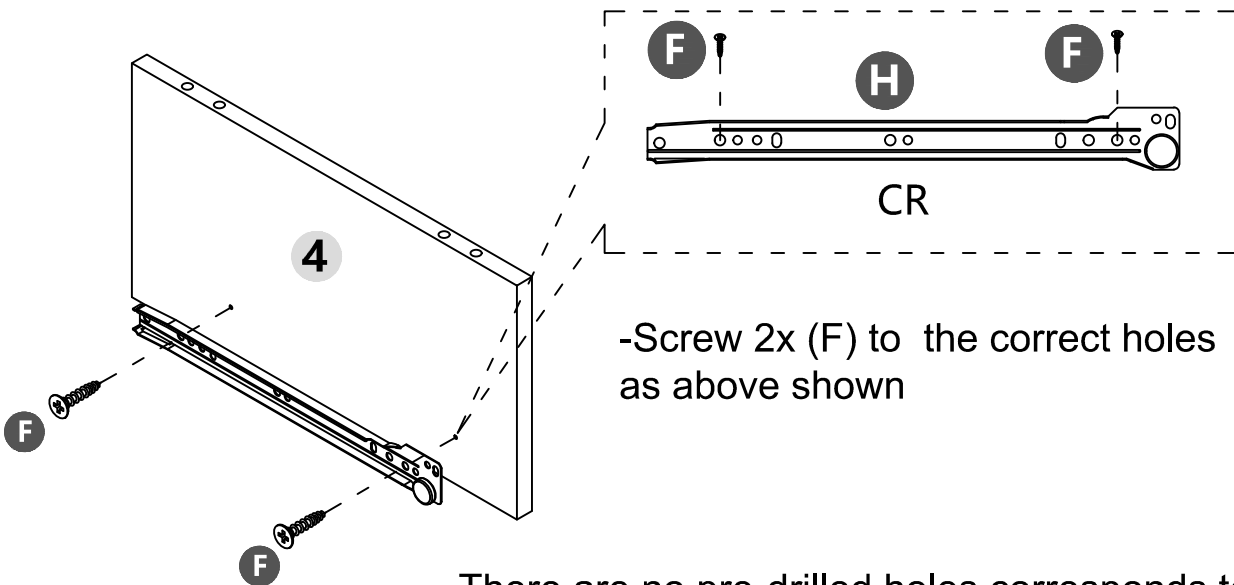

There are no pre-drilled holes corresponds to the UPPER row holes of the tightening. We need to confirm the position of the track slide, then screw the (F) on.

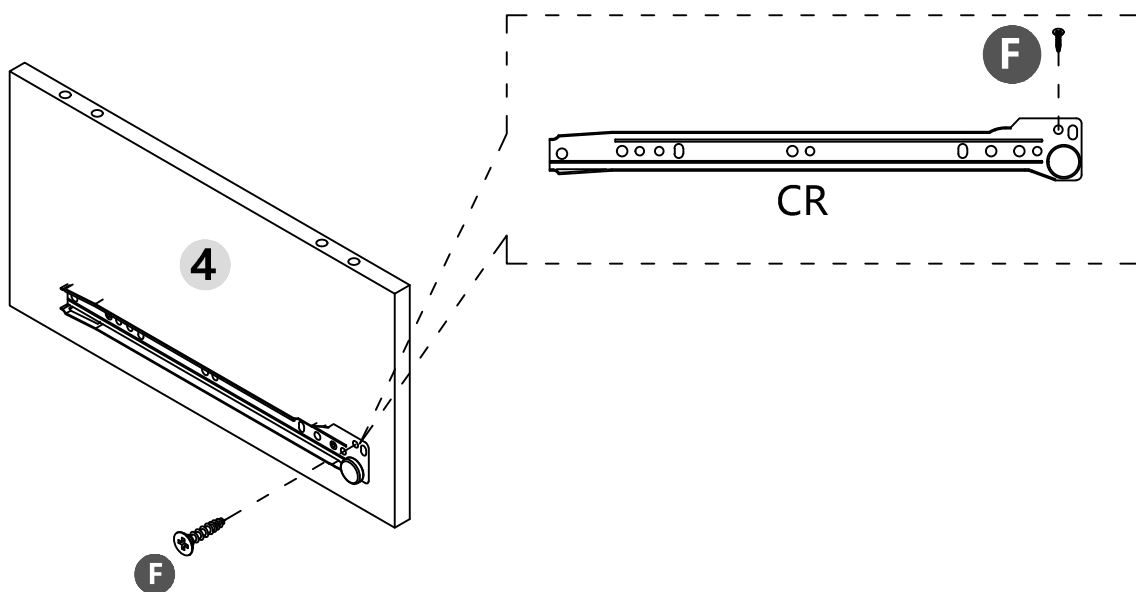

STEP 3-2

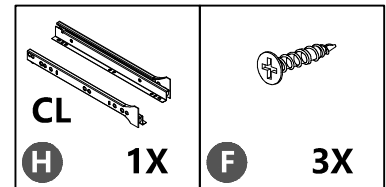

- Install the drawer slides(H) on the right side of upper middle partition panel(4).
- There is a CL sign on the track. Install CL track on the side with 2 big holes of panel (4)
- Screw(F)to tighten the track slides as below shown.

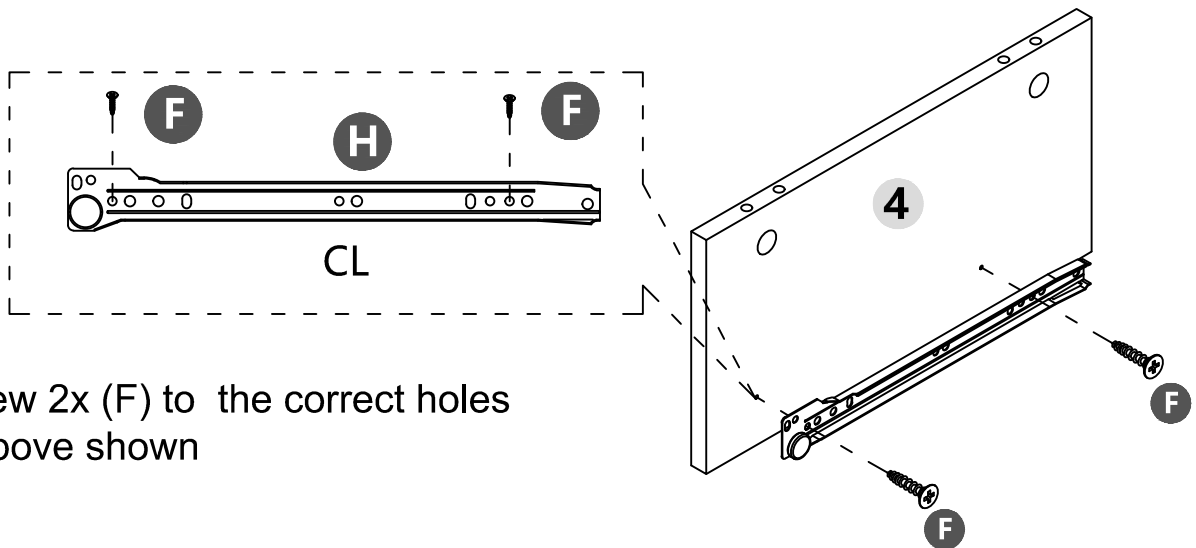

-Screw 2x (F) to the correct holes as above shown

There are no pre-drilled holes corresponds to the UPPER row holes of the tightening. We need to confirm the position of the track slide, then screw the (F) on.

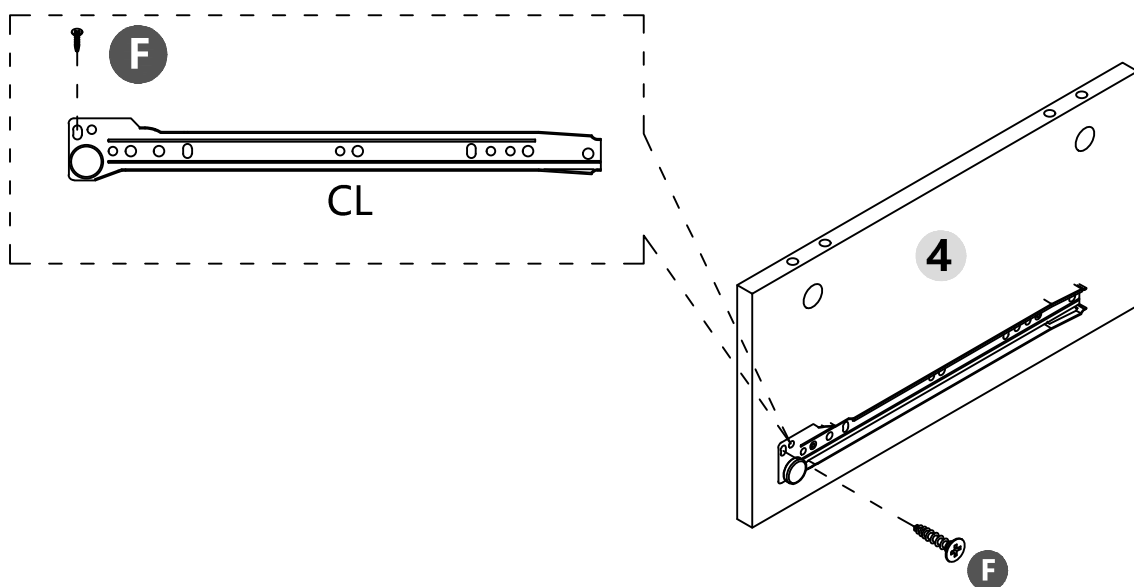

STEP 4

-Screw (L) to lock (5) and (4) as below shown

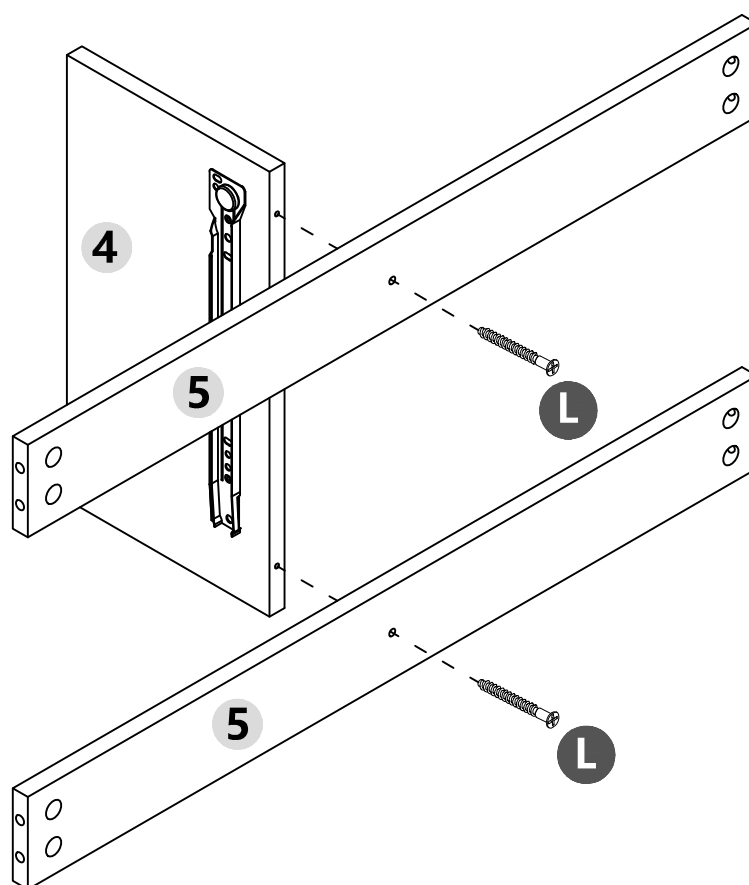
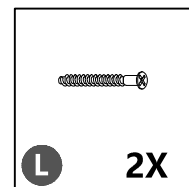

STEP 5

- Screw(A) to(7)&(8)as below shown
- Attach (20)to(7)&(8) as below shown
- Screw (B) to lock the (20) as below shown

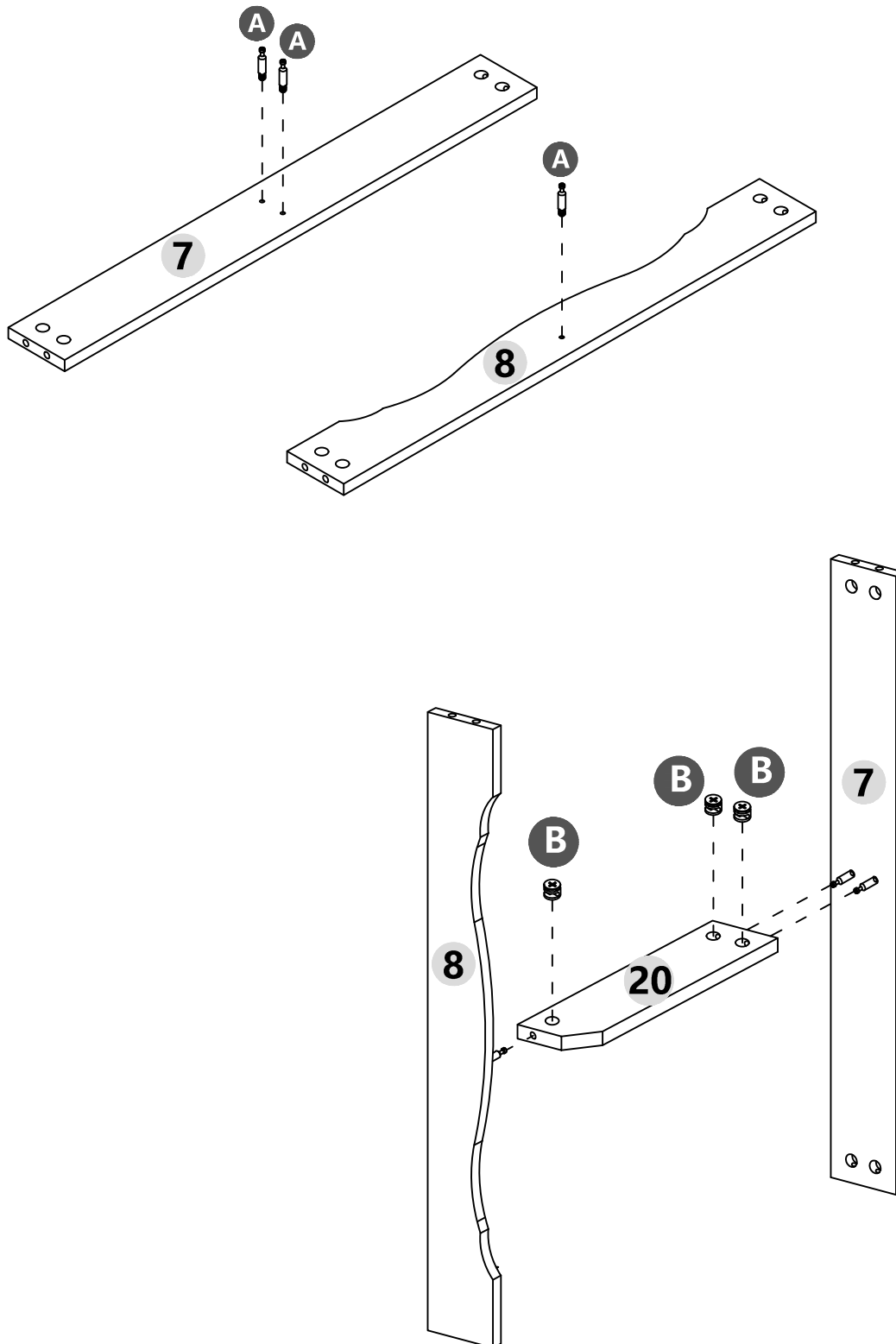
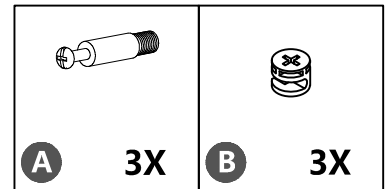

STEP 6



B

12X

- Attach(5)&(6)&(7)&(8) to (2) as below shown
- Screw (B) to lock the (5)&(6)&(7)&(8)as below shown

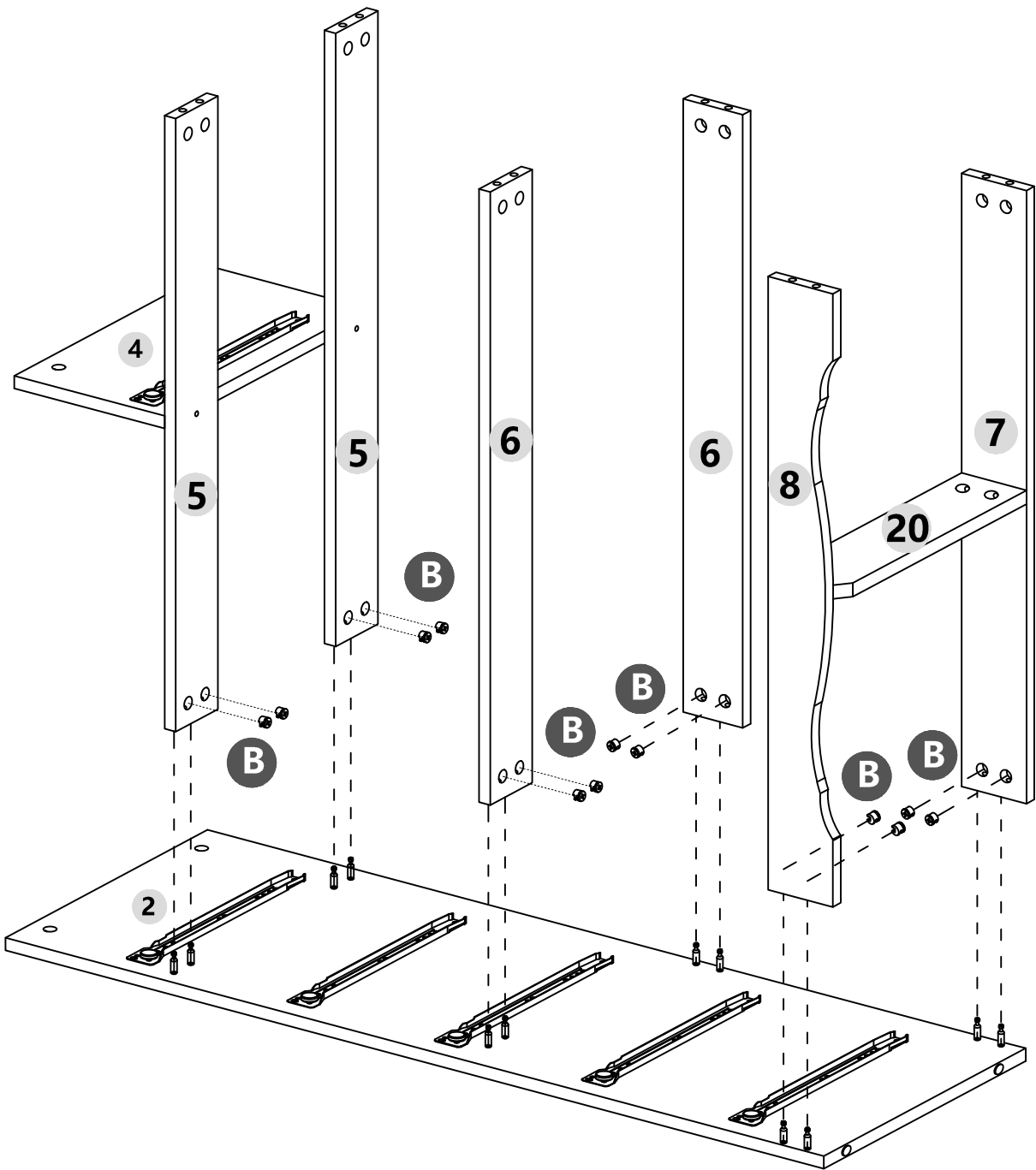

STEP 7



B

12X

- Attach(3)to (5)&(6)&(7)&(8) as below shown
- Screw (B) to lock the (5)&(6)&(7)&(8)as below shown

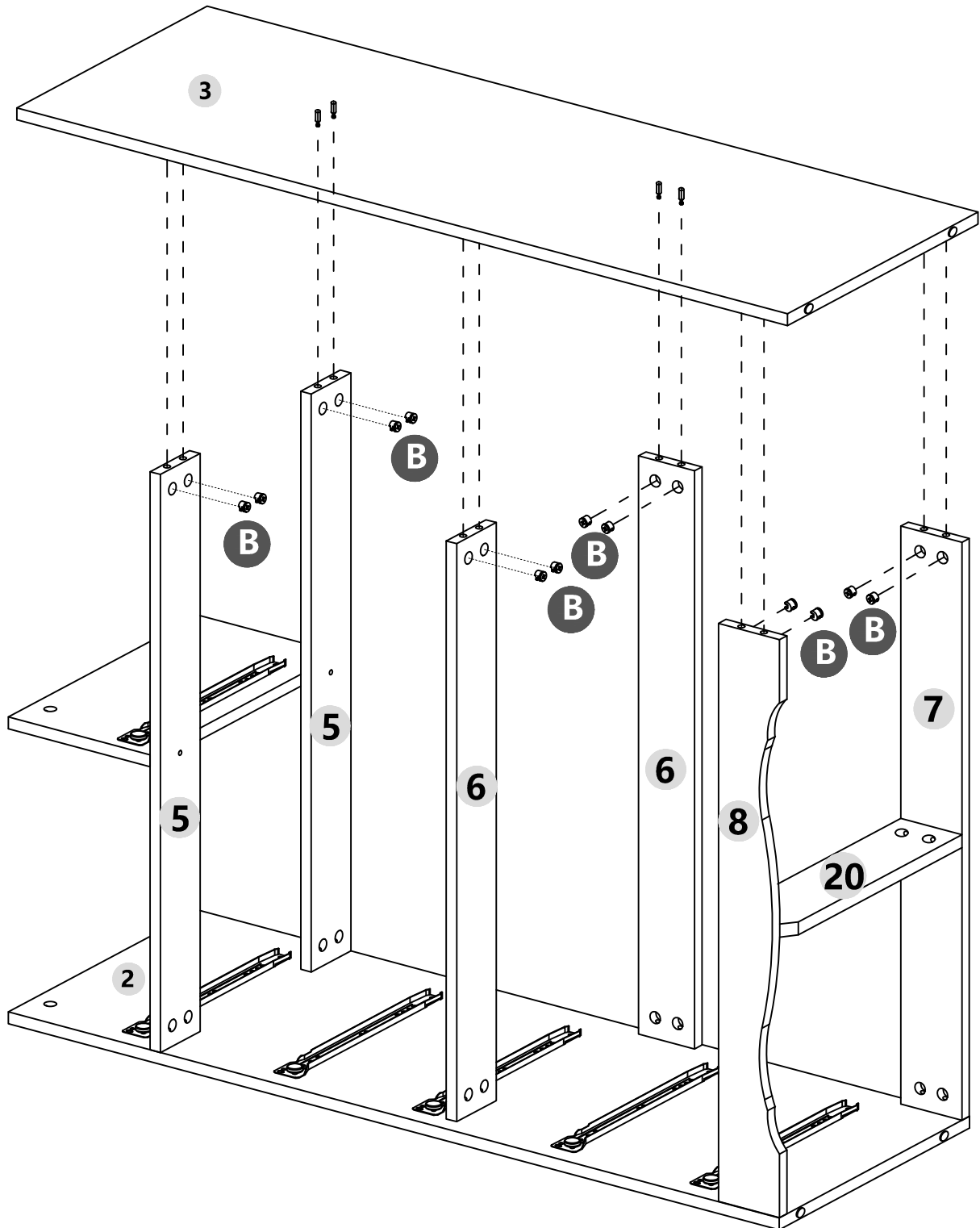

STEP 8

- Screw(A)to (1)as below shown
- Screw (C)to (1)as below shown
- Flip(1), attach (1) to (2)&(3)&(4)as below shown
- Screw (B)to lock the (2)&(3)&(4)as below show

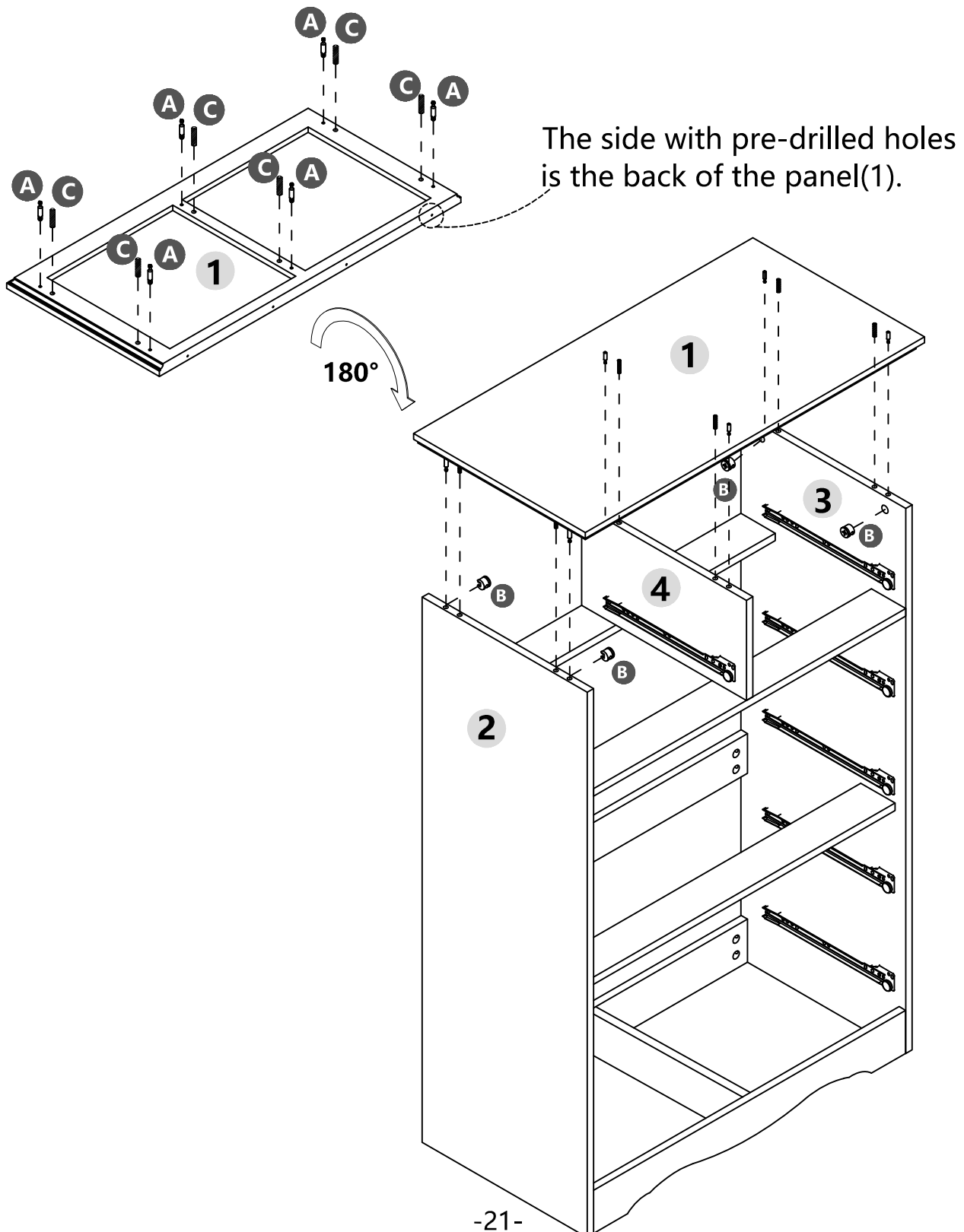
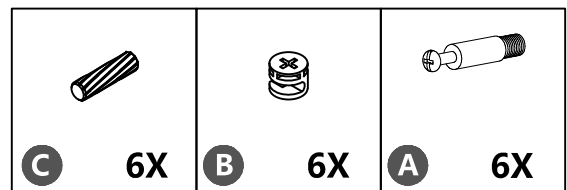

STEP 9

- Screw(G) to Back panel (9)&(10) as below shown
- Stick (J) to (1)&(9), use (G) locked

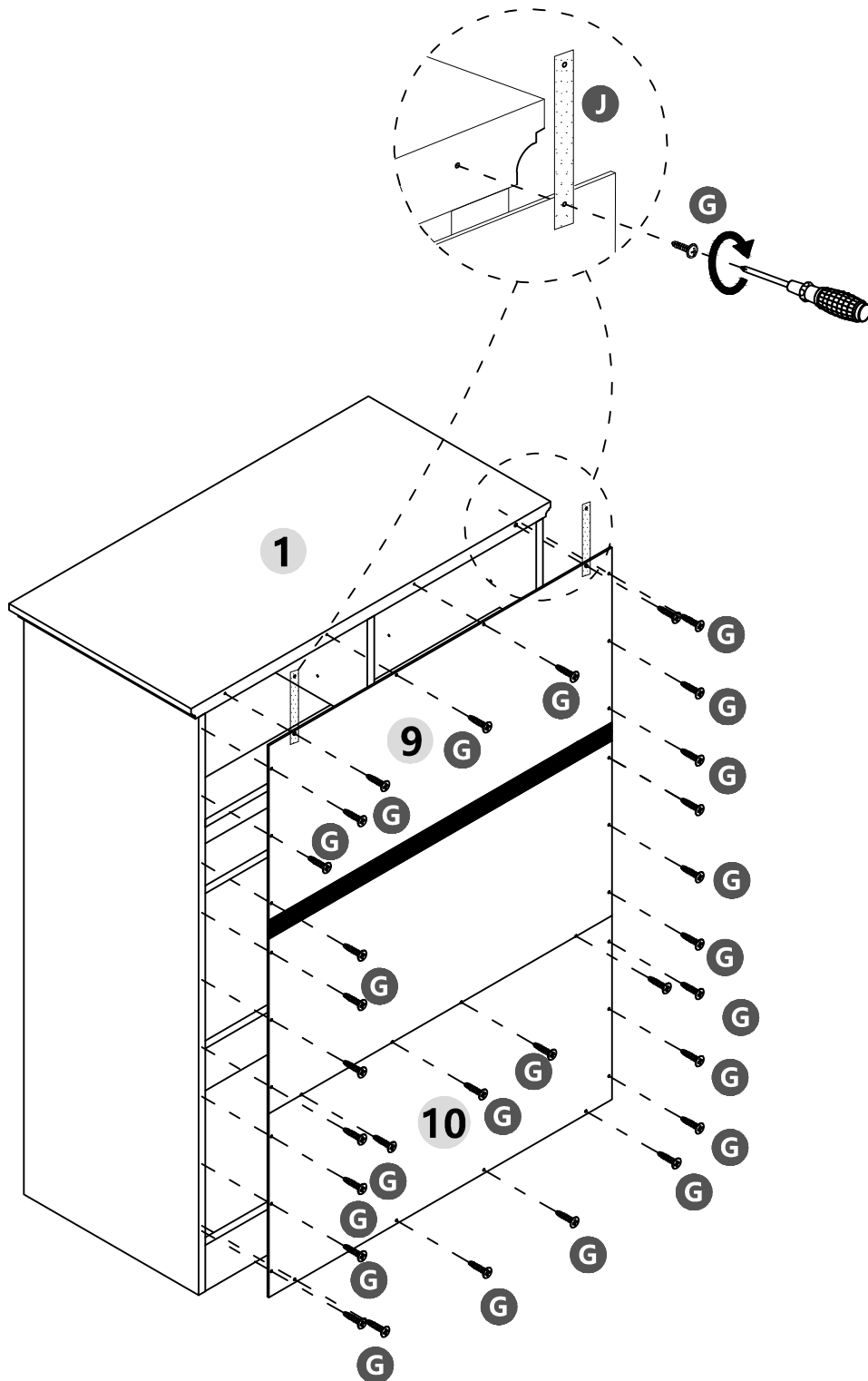
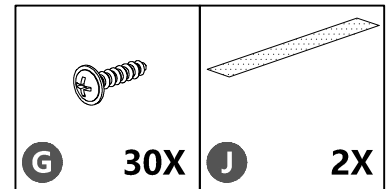

STEP 10-1

- Screw(A) to(19)as below shown
- Attach (11)&(12)&(17)to(19) as below shown
- Screw (B) to lock the (11)&(12)&(17) as below shown

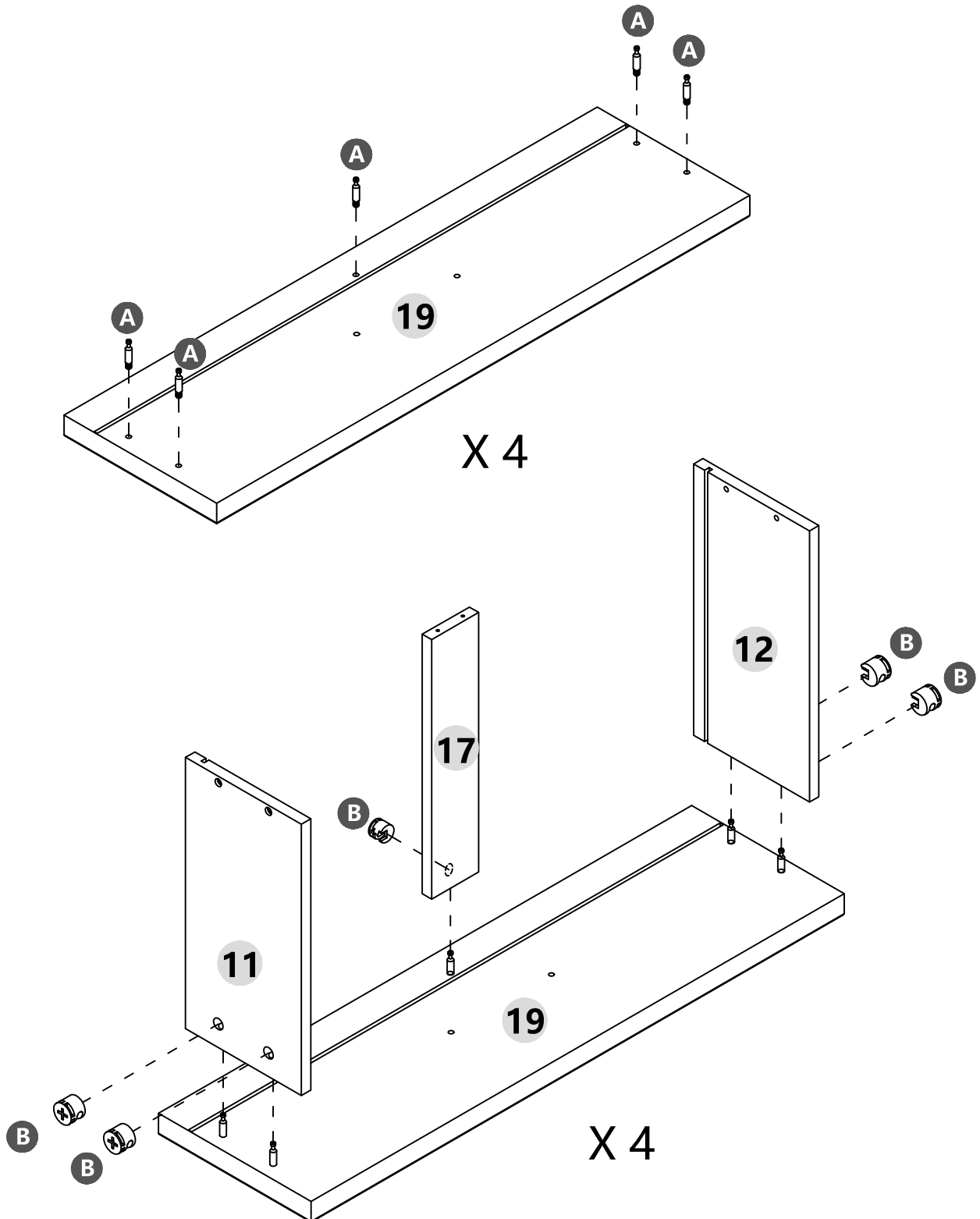
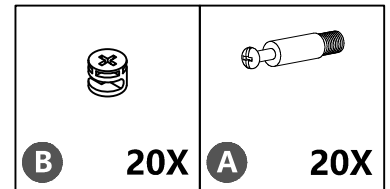

STEP 10-2

- Attach (14)&(16) to (11)&(12) as below shown
- Screw (E) to attach (11)&(12) to (14) as below shown
- Screw (E) to attach (14) to (17) as below shown
- Screw (I)&(D) to (19) as below shown

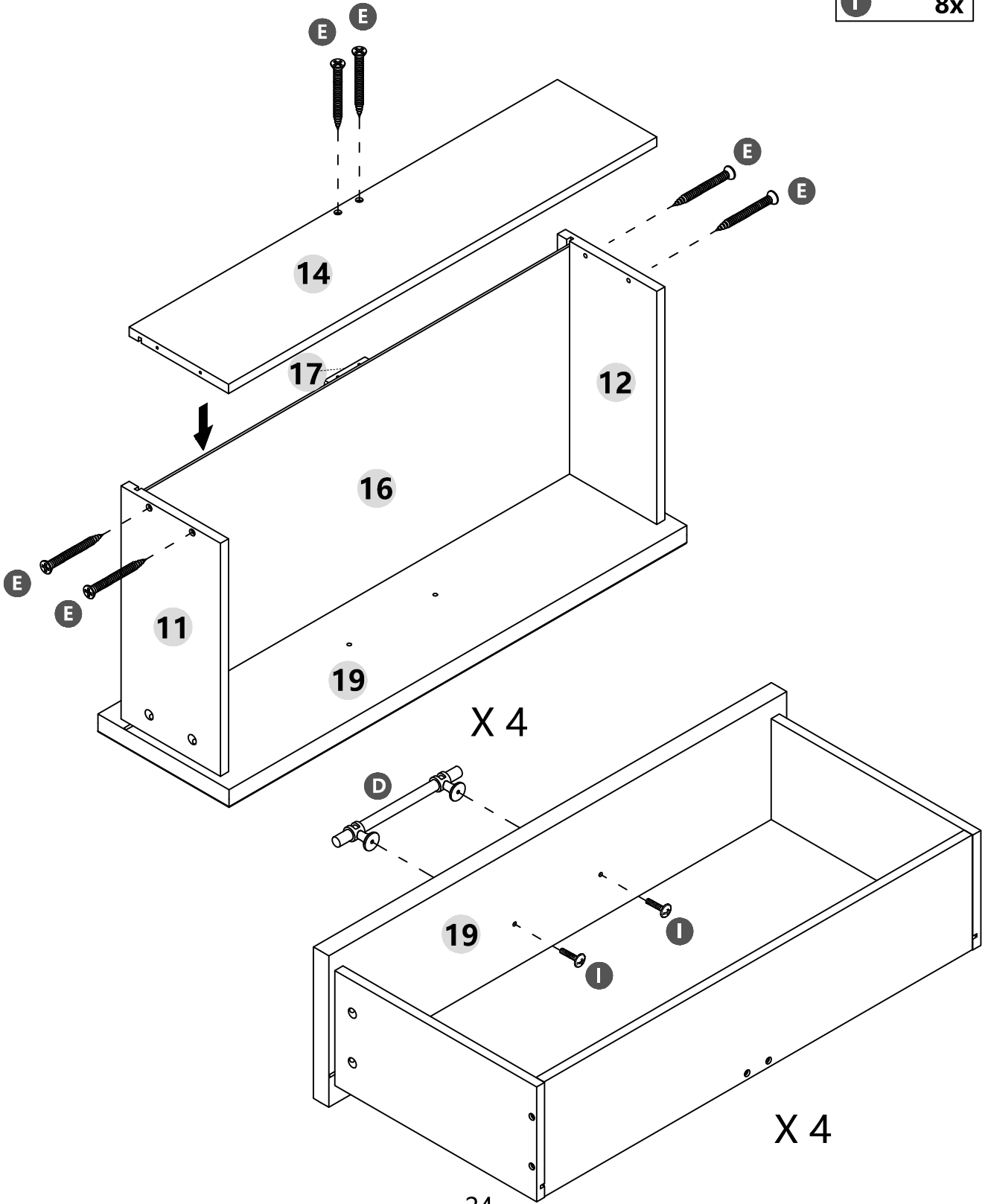
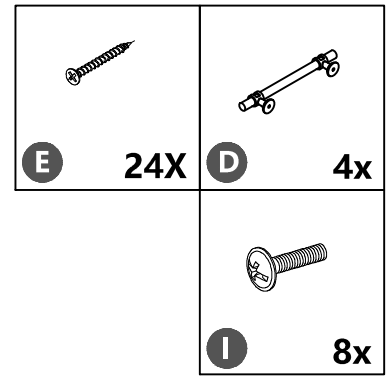

STEP 10-3

-install the drawer slides (H) on the drawer side panels (11)&(12) as below shown

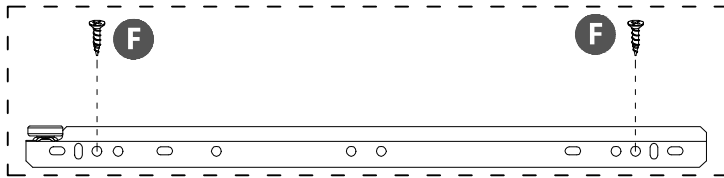
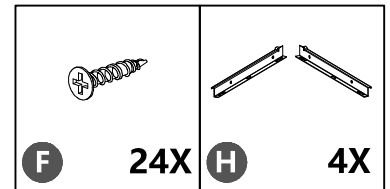

If necessary, install one more screw in the middle of the drawer slide.

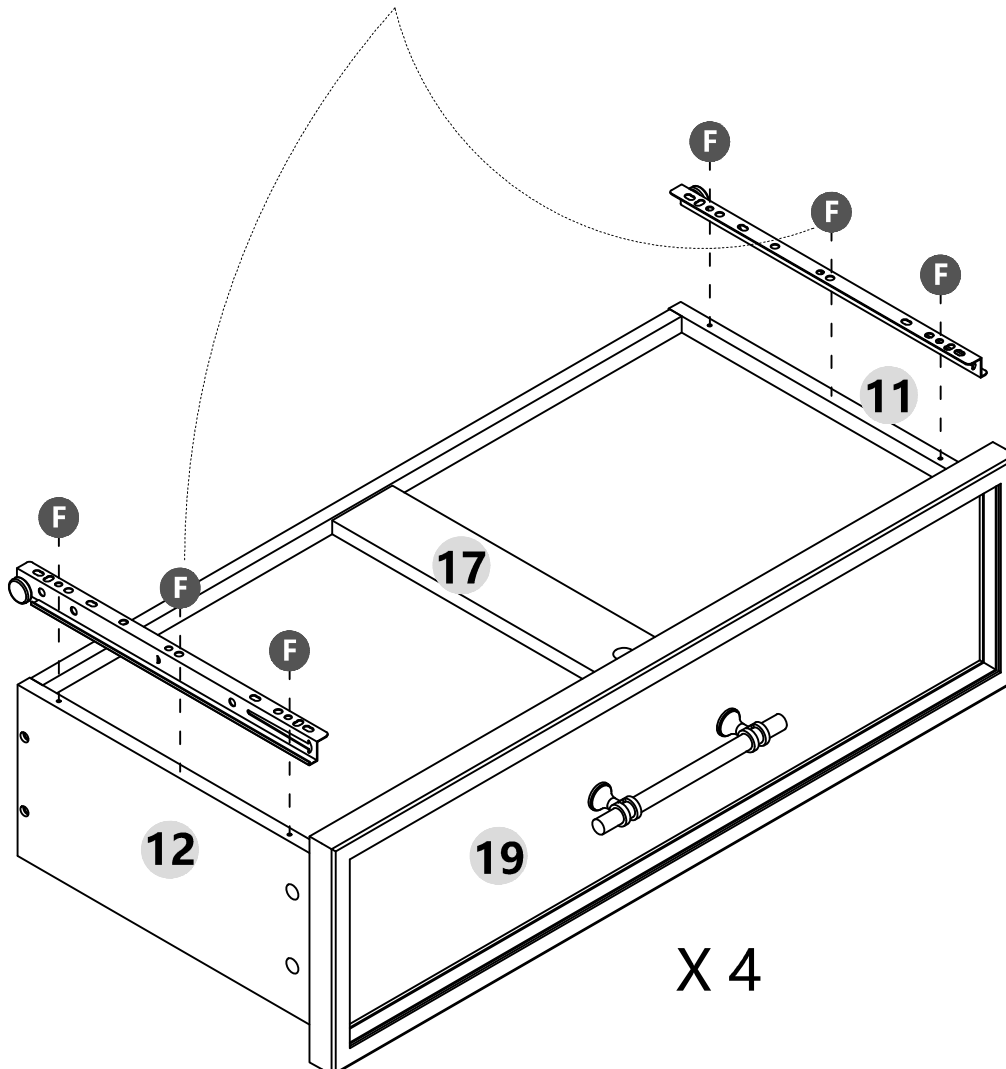

Repeat the previous step to install the remaining drawers

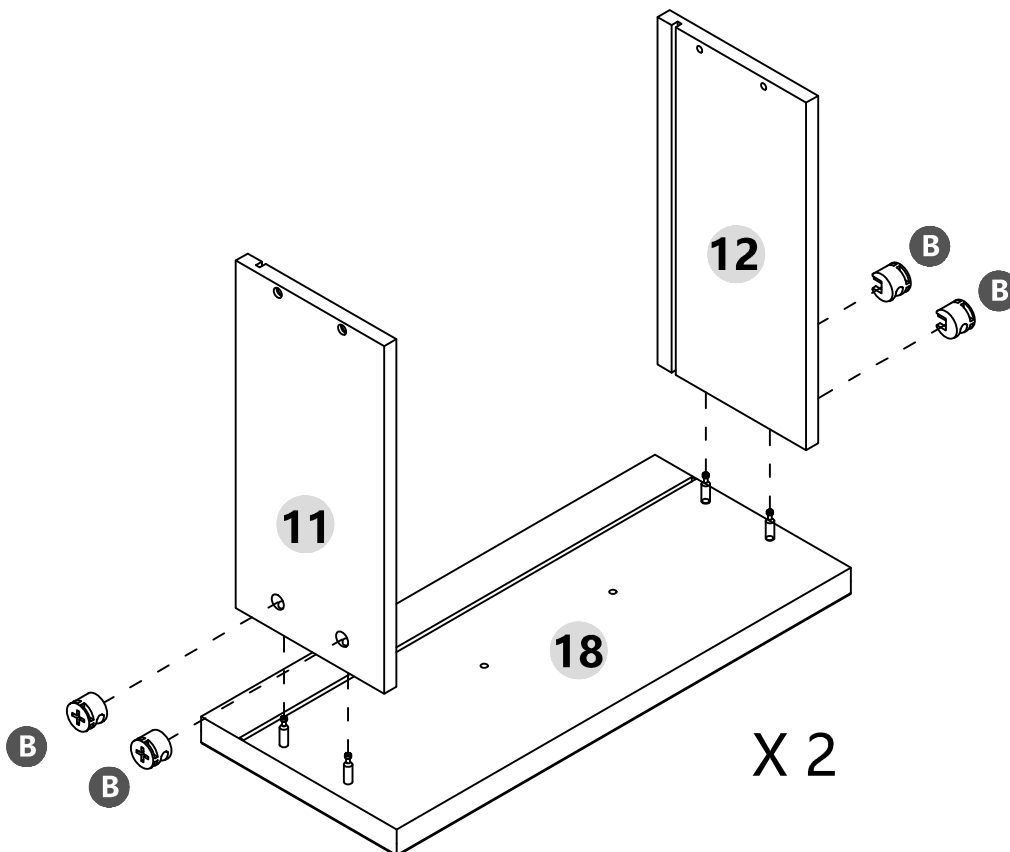
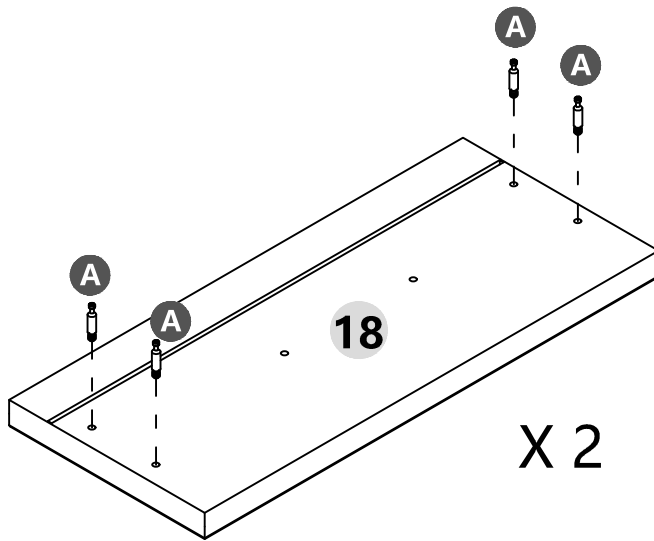
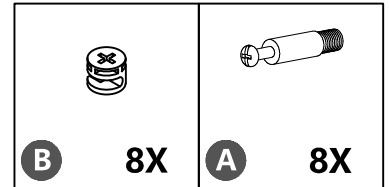

STEP 11-1

- Screw(A) to(18)as below shown
- Attach (11)&(12)&(18) as below shown
- Screw (B) to lock the (11)&(12) as below shown



STEP 11-2

- Attach (13)&(15) to (11)&(12) as below shown
- Screw (E) to attach (11)&(12) to (13) as below shown
- Screw(I)&(K) to (18) as below shown

 E 8X	 K 2x
	 I 4x

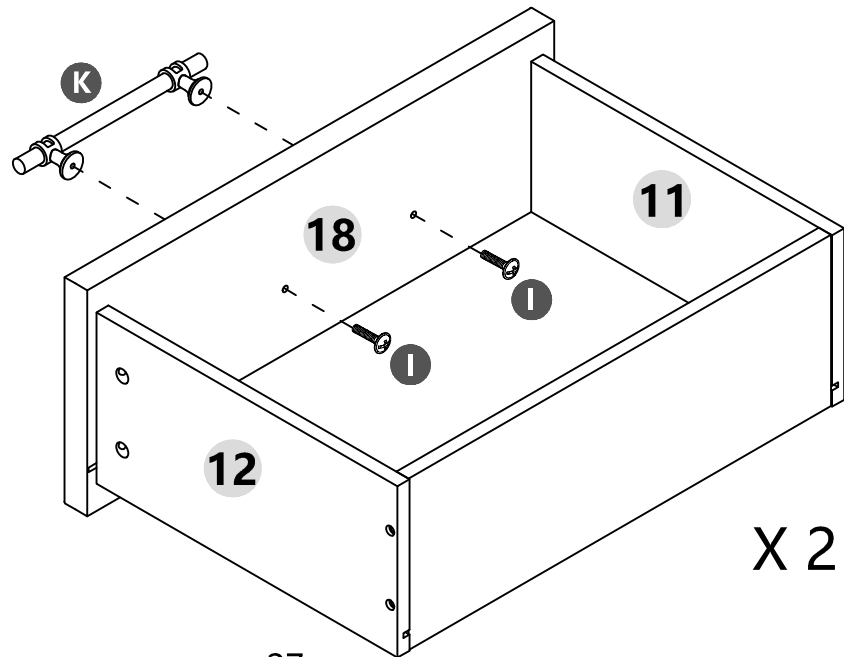
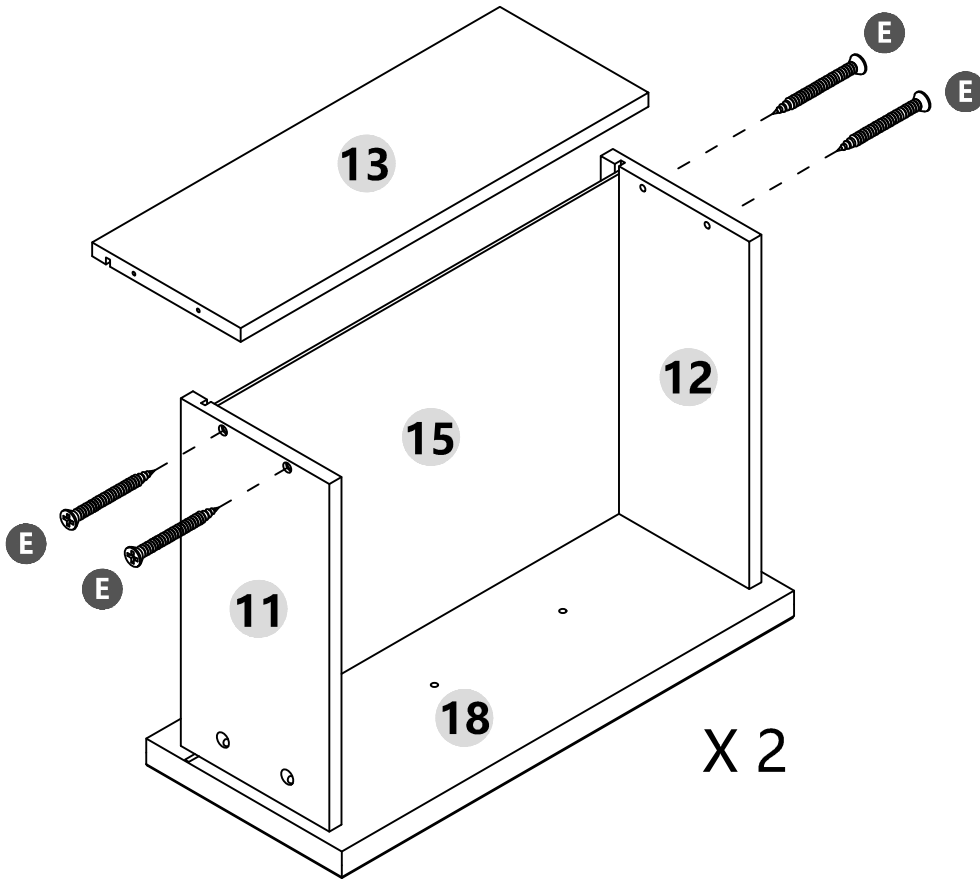

STEP 11-3

-install the drawer slides (H) on the drawer side panels (11)&(12) as below shown

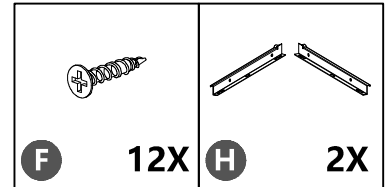

If necessary, install one more screw in the middle of the drawer slide.

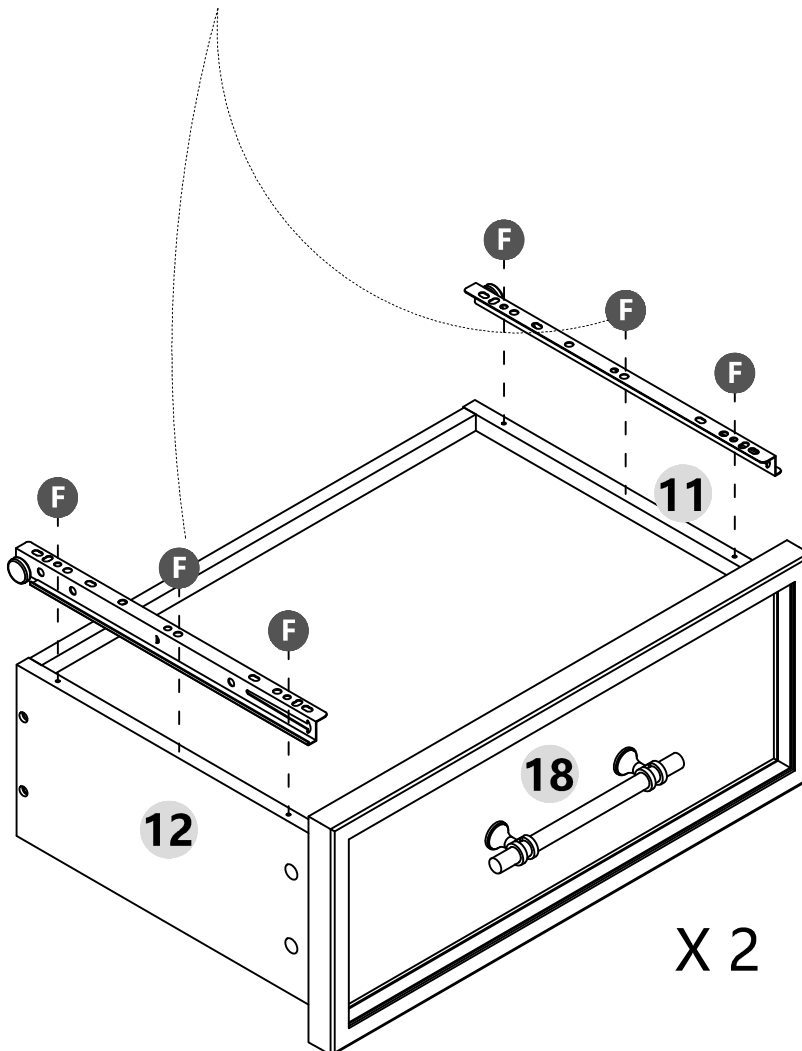

Repeat the previous step to install the remaining drawers

STEP 12

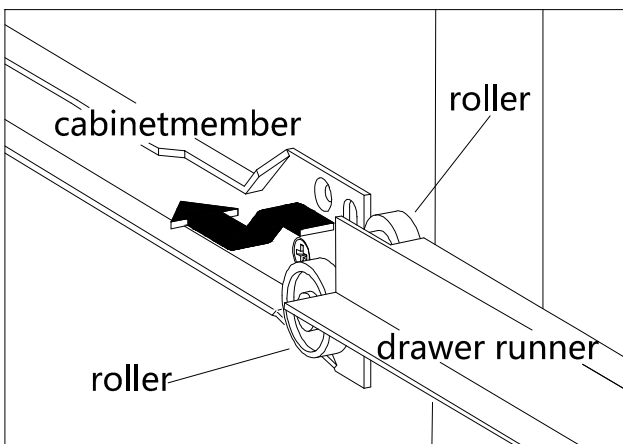
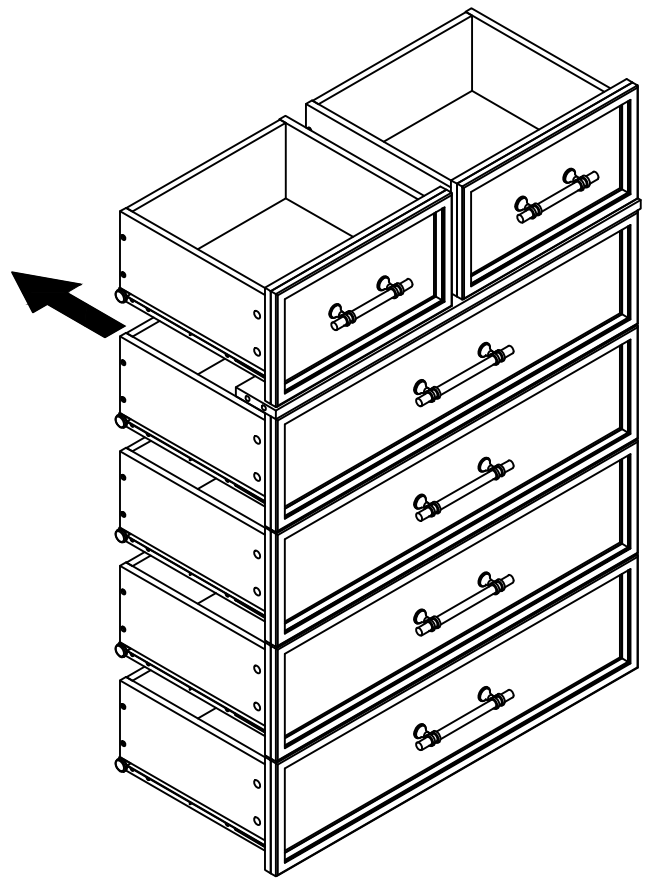
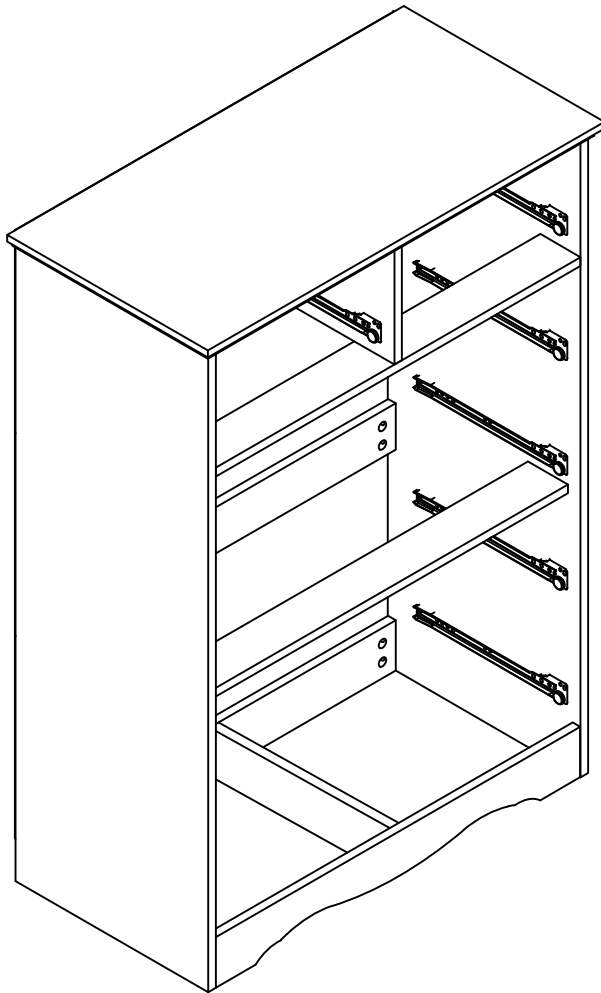

STEP 13

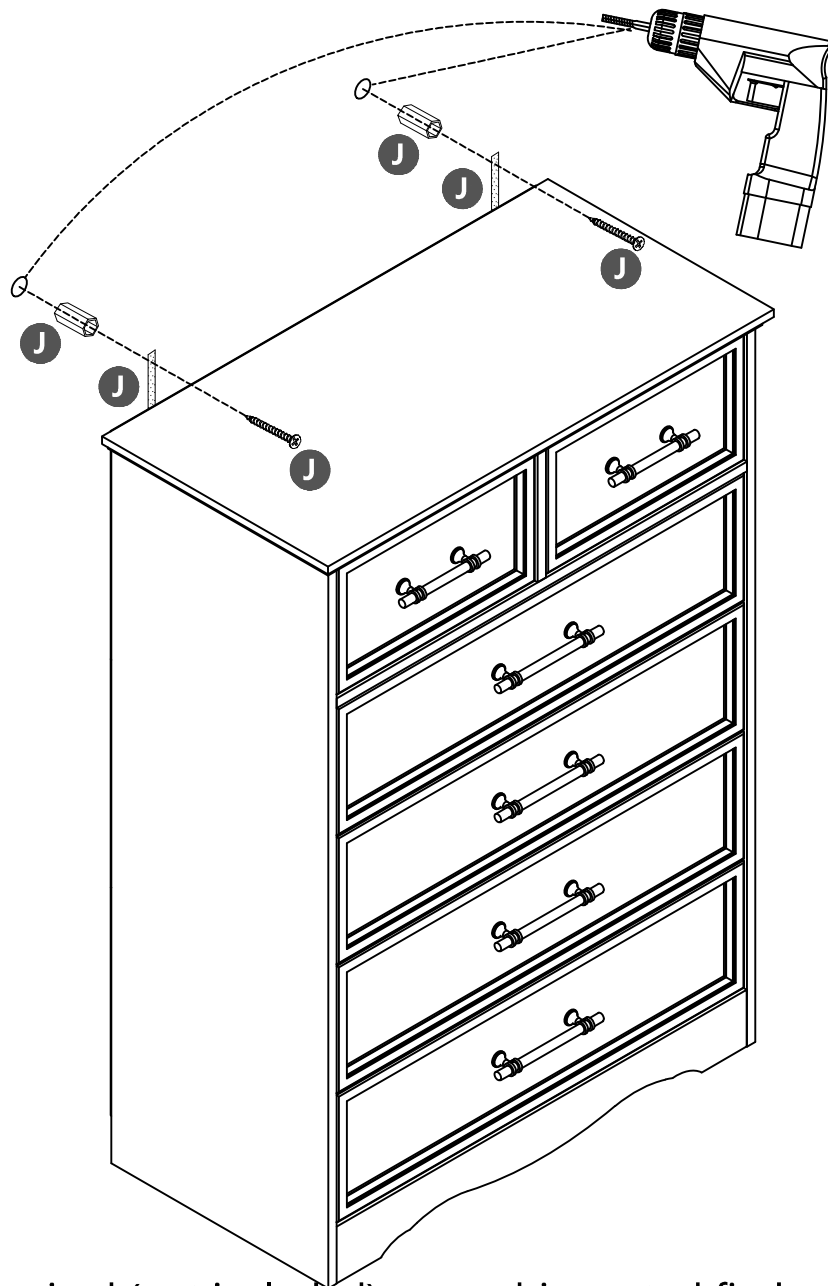

Tools required (not included): screwdriver, stud finder, tape measure, pencil, power drill and 3/16" drill bit.

Now, follow the guide printed on the plastic bag containing the tipping restraint hardware to attach the tip-over restraints to the unit and the wall.

NOTE: The tipping restraint hardware included is for wooden stud wall construction. It must be attached to a wall stud. Depending upon your wall construction, different anchor hardware may be required. Please contact your local hardware store for assistance. Young children can be seriously injured by tipping furniture. You must install the tipping restraint hardware with the unit to prevent the unit from tipping, causing any accidents or damage. The tipping restraints are intended only as a deterrent, they are not a substitute for proper adult supervision, the tipping restraints are not earthquake restraints. If you wish to add the extra security of earthquake restraints, they must be purchased and installed separately.

Finally, you got a 6-drawer dresser!

