

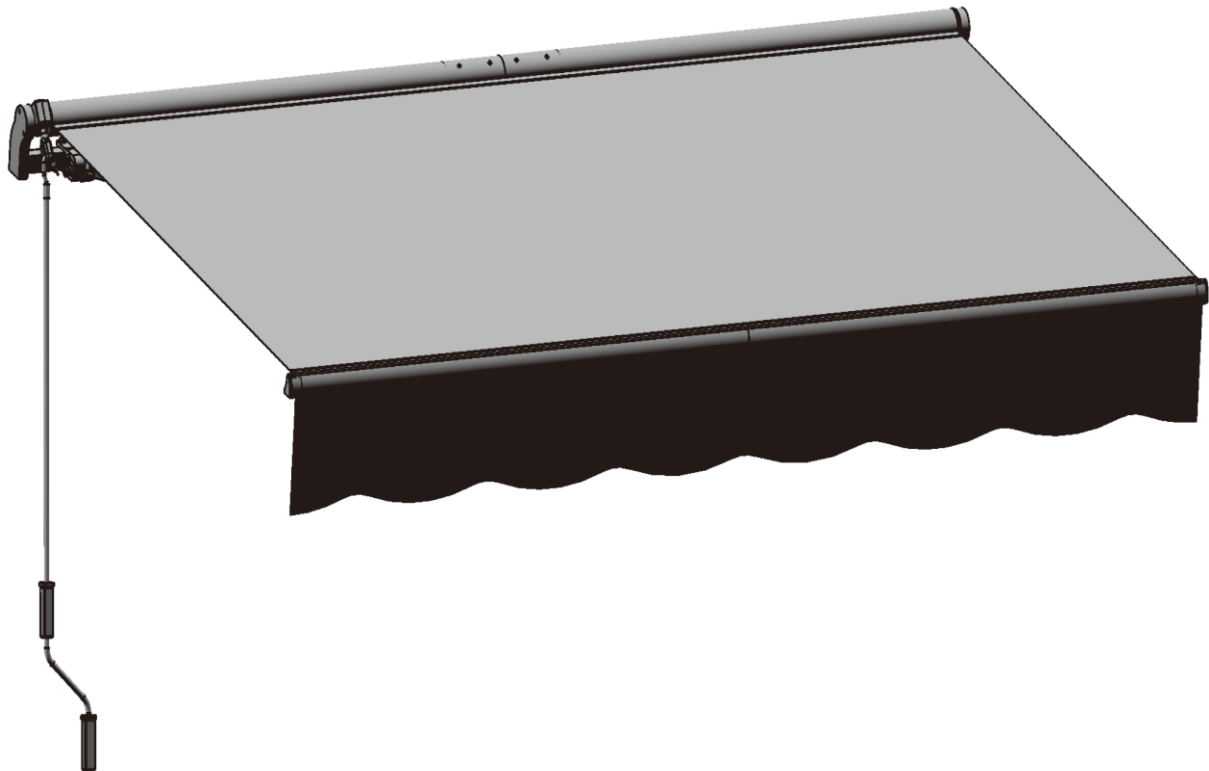

IN221100585V02\_GL



**EN\_Tips:** Please do not use in bad weather to avoid damage.

**FR\_Conseils :** Ne pas utiliser par mauvais temps afin d'éviter tout dommage.

**ES\_Consejos:** No utilizar con mal tiempo para evitar daños.

**PT\_Dicas:** Não utilizar com mau tempo para evitar danos.

**DE\_Tipps:** Bitte nicht bei schlechtem Wetter verwenden, um Schäden zu vermeiden.

**IT\_Suggerimenti:** non utilizzare in caso di maltempo per evitare danni.

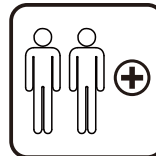
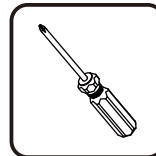
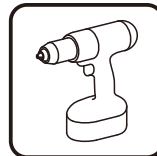
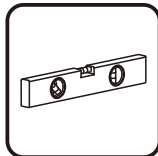
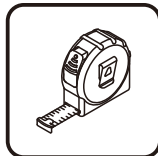
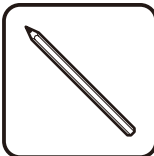
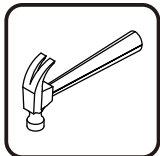

Tools Recommended

**EN\_IMPORTANT, RETAIN FOR FUTURE REFERENCE: READ CAREFULLY.**

**FR\_IMPORTANT: A LIRE ATTENTIVEMENT ET À CONSERVER POUR CONSULTATION ULTÉRIEURE.**

**ES\_IMPORTANTE, LEA Y GUARDE PARA FUTURAS REFERENCIAS.**

**PT\_IMPORTANTE, RETER PARA REFERÊNCIA FUTURA: LEIA ATENTAMENTE.**

**DE\_WICHTIG! SORGFÄLTIG LESEN UND FÜR SPÄTER NACHSCHLAGEN AUFBEWAHREN.**

**IT\_IMPORTANTE! CONSERVARE IL PRESENTE MANUALE PER FUTURO RIFERIMENTO E LEGGERLO ATTENTAMENTE.**

**EN**

**Dear customer,**

Thank you for purchasing this product. So that your appliance serves you well, please read all the instructions in this user's manual. If you have any questions, please contact our customer care center, Our contact details are below:

**FR**

**Cher client,**

Nous vous remercions d'avoir acheté ce produit. Afin que vous puissiez profiter pleinement de votre appareil, veuillez lire toutes les instructions de ce manuel d'utilisation. Si vous avez la moindre question, veuillez contacter notre centre d'assistance à la clientèle, Nos coordonnées sont les suivantes:

**DE**

**Sehr geehrter Kunde,**

Vielen Dank, dass Sie dieses Produkt erworben haben. Damit Ihr Gerät Ihnen gute Dienste leistet, lesen Sie bitte alle Hinweise in diesem Benutzerhandbuch. Wenn Sie Fragen haben, wenden Sie sich bitte an unser Kundendienstzentrum, Unsere Kontaktdaten stehen unten:

**ES**

**Queridos clientes,**

Gracias por comprar este producto. Para que su electrodoméstico le sirva mejor, lea todas las instrucciones de este manual del usuario. Si tiene alguna pregunta, comuníquese con nuestro Centro de Atención al Cliente, Nuestros datos de contacto son los siguientes:

**PT**



**Caros clientes,**

Obrigado por adquirir este produto. Para que o seu aparelho o sirva melhor, leia todas as instruções deste manual do utilizador. Se tiver alguma dúvida, por favor contacte o nosso Centro de Atendimento ao Cliente, Os nossos dados de contacto são os seguintes:

**IT**

**Caro Cliente,**







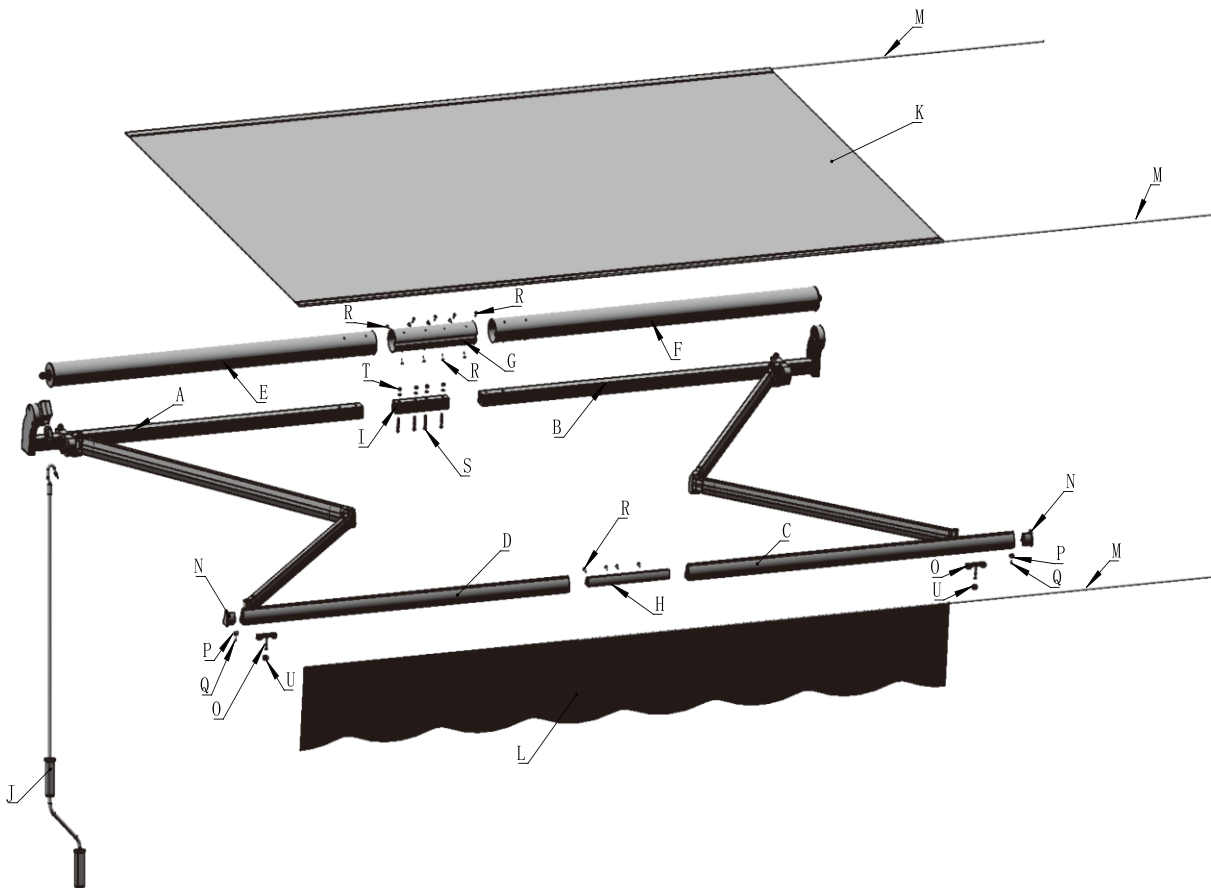



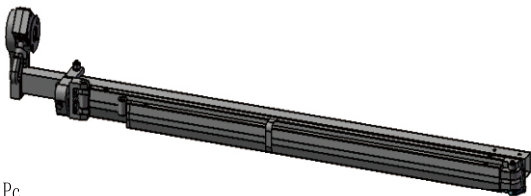
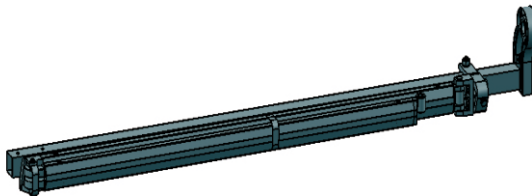



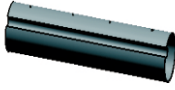

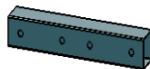

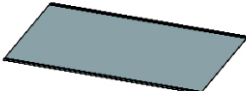



Grazie per aver acquistato questo prodotto. Per servirti meglio con questo apparecchio ti prego di leggere tutte le istruzioni in presente manuale utente. In caso di dubbio, si prega di contattare il nostro centro assistenza clienti, I nostri dettagli di contatto sono di seguito:

<b>Country</b>	<b> Phone</b>	<b> Email</b>
US	001-877-644-9366	customerservice@aosom.com
CA	416-792-6088	customerservice@aosom.ca
UK	0044-800-240-4004	enquiries@mhstar.co.uk
DE	0049-0(40)-88307530	service@aosom.de
FR	0033-1-84166106	aosom@mhfrance.fr
ES	0034-931294512	atencioncliente@aosom.es
PT	0034-931294512	info@aosom.pt
IT	0039-0249471447	clienti@aosom.it

- |                                |  |                    |
|--------------------------------|--|--------------------|
| A. Torsion bar with Arm(Left)  | J. Hand Crank                              | S. M6X40           |
| B. Torsion bar with Arm(Right) | K. Fabric                                  | T. M6              |
| C. Fornt bar(Right)            | L. Valance                                 | U. M10             |
| D. Fornt bar(Left)             | M. Fabric Liner                            | V. M8X55           |
| E. Roller(Left)                | N. Front bar caps(Left and Right)          | W. M8              |
| F. Roller(Right)               | O. Armbar Link                             | X. Expansion Screw |
| G. Roller connector            | P. Plastic Bolt for cover and Fabric Liner | Y. Wall Brackets   |
| H. Front bar connector         | Q. St 3x10                                 |                    |
| I. Torsion bar connector       | R. St 14x15                                |                    |

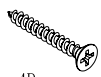

PARTS LIST

 <p>A 1Pc</p>		 <p>B 1Pc</p>					
 <p>C 1Pc</p>		 <p>D 1Pc</p>					
 <p>E 1Pc</p>		 <p>F 1Pc</p>					
 <p>G 1Pc</p>	 <p>H 1Pc</p>	 <p>I 1Pc</p>	 <p>J 1Pc</p>				
 <p>K 1Pc</p>	 <p>L 1Pc</p>	 <p>M 3Pc</p>	 <p>N 2Pcs</p>	 <p>O 2Pcs</p>			
 <p>P 2Pcs</p>	 <p>Q 2Pcs</p>	 <p>R 16Pcs</p>	 <p>S 4Pcs</p>	 <p>T 4Pcs</p>	 <p>U 2Pcs</p>	 <p>V 2Pcs</p>	 <p>W 2Pcs</p>
 <p>X 4Pcs</p>	 <p>Y 2Pcs</p>	 <p>Z 4Pcs</p>					

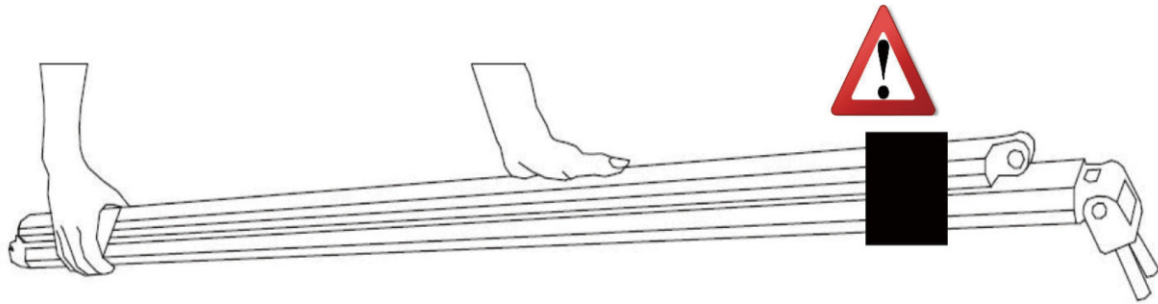

# WARNING!

**AWNING ARMS WILL CAUSE INJURY!**

**ONLY CUT AWNING ARMS TAPES  
AFTER AWNING FULLY ASSEMBLED!!!**

- ALEKO TEAM

**X wrong**



**✓ right**



**WARNING**

**WILL CAUSE INJURY!**

**ONLY CUT AFTER FULLY ASSEMBLED**

STEP1: Thread the fabric Line , and cut the Fabric Line as long as the Fabric

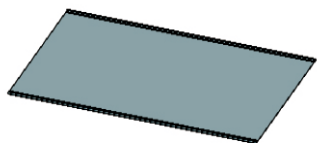
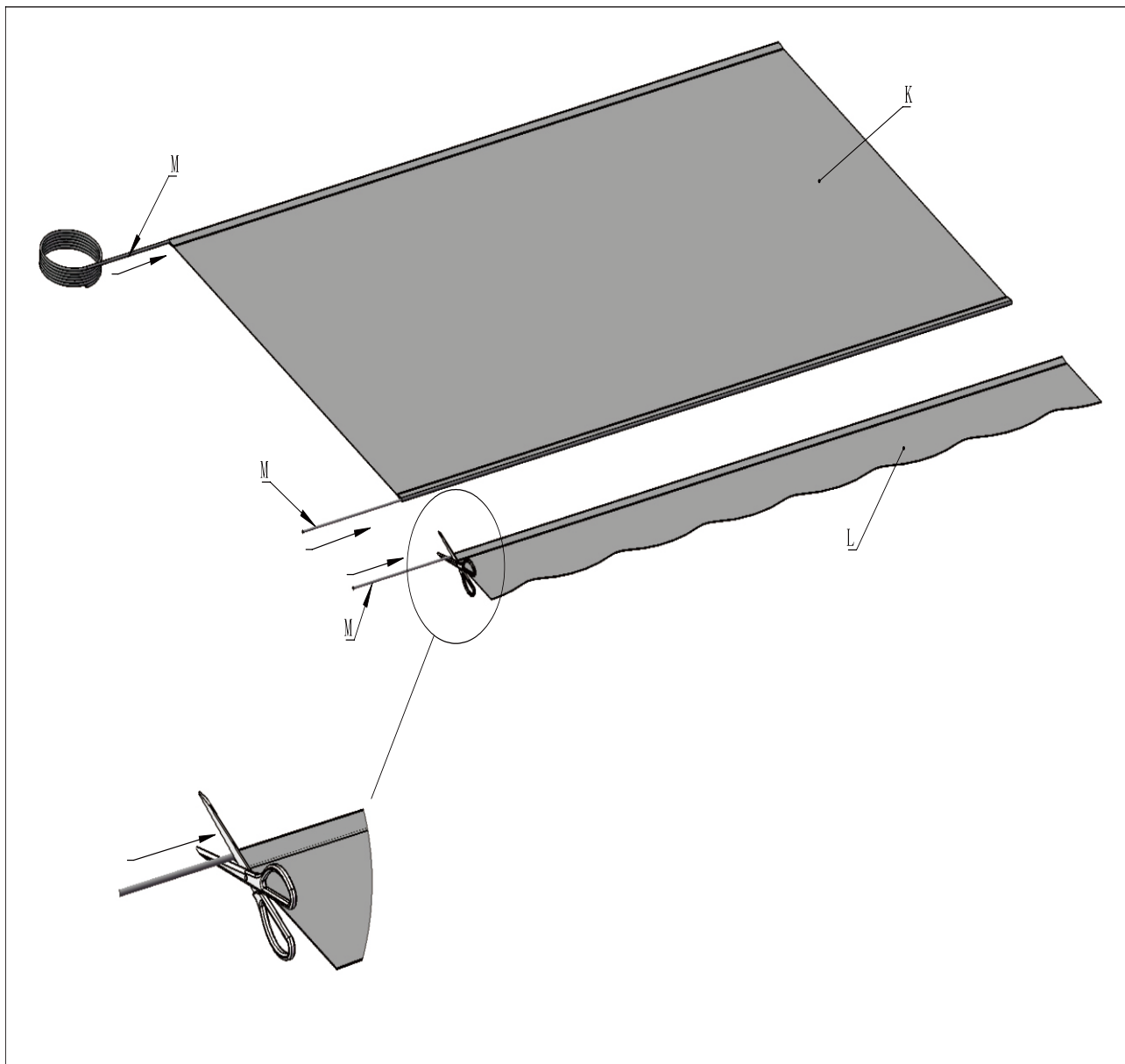

K 1Pc









L 1Pc

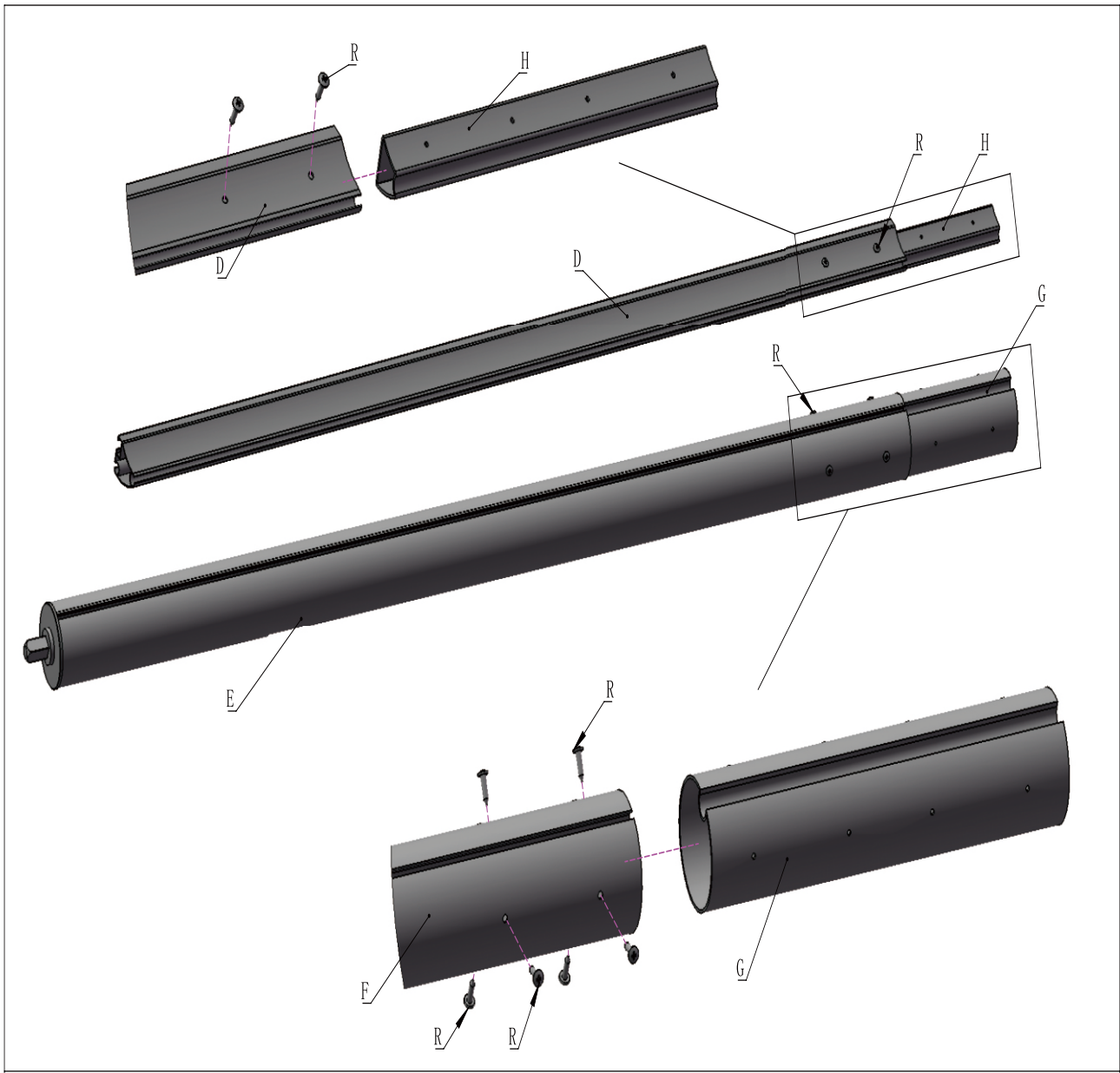

M 3Pc

STEP2:Connecting Roller Tube and Front bar (LEFT)



- |   |   |   |   |   |
|---|---|---|---|---|
|  |  |  |  |  |
| D 1Pc   | H 1Pc   | E 1Pc   | G 1Pc   | R 8Pcs  |

STEP3: Fabric Assembly and Connecting Roller and Front bar

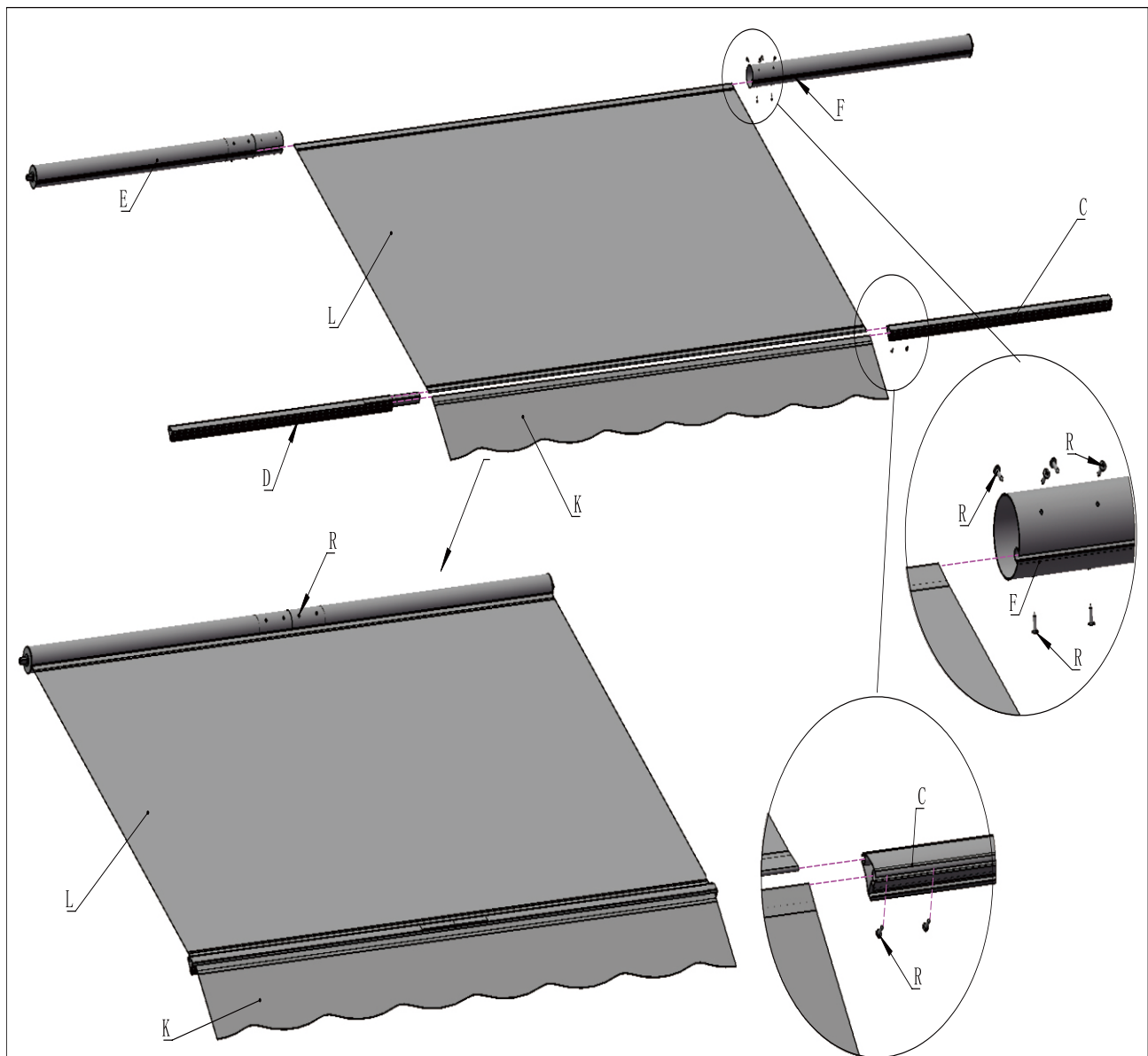

- |       |       |        |
|-------|-------|--------|
|       |       |        |
| C 1Pc | F 1Pc | S4X15  |
|       |       | R 8Pcs |

- STEP4:1.Put the Arm-bar Link into the Front bar  
2. Put P part into the Front bar and Lock it with Screw Q  
3.Tap the Front bar Caps

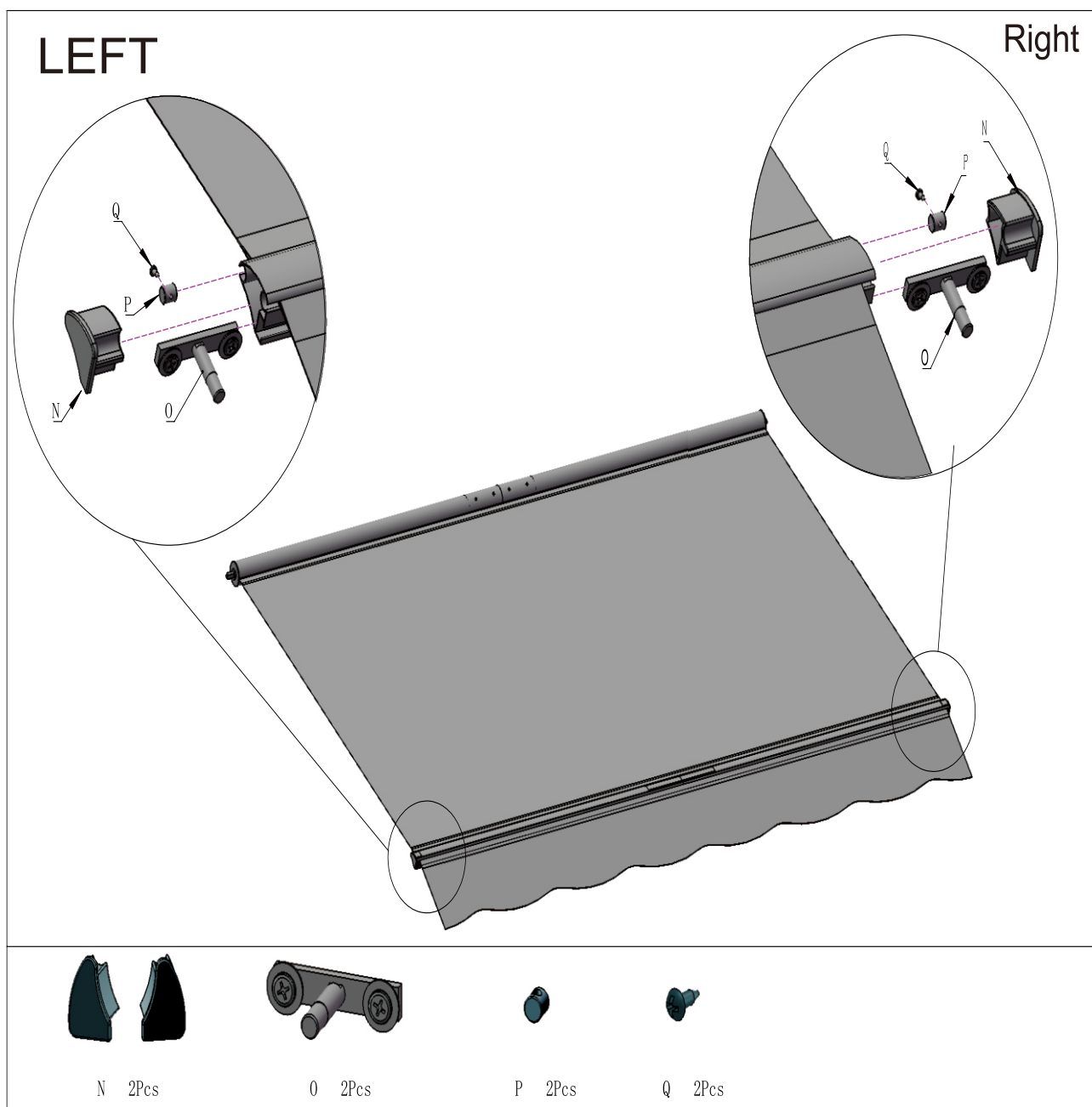

STEP5:Roll the awning Fabric as tightly as Possible

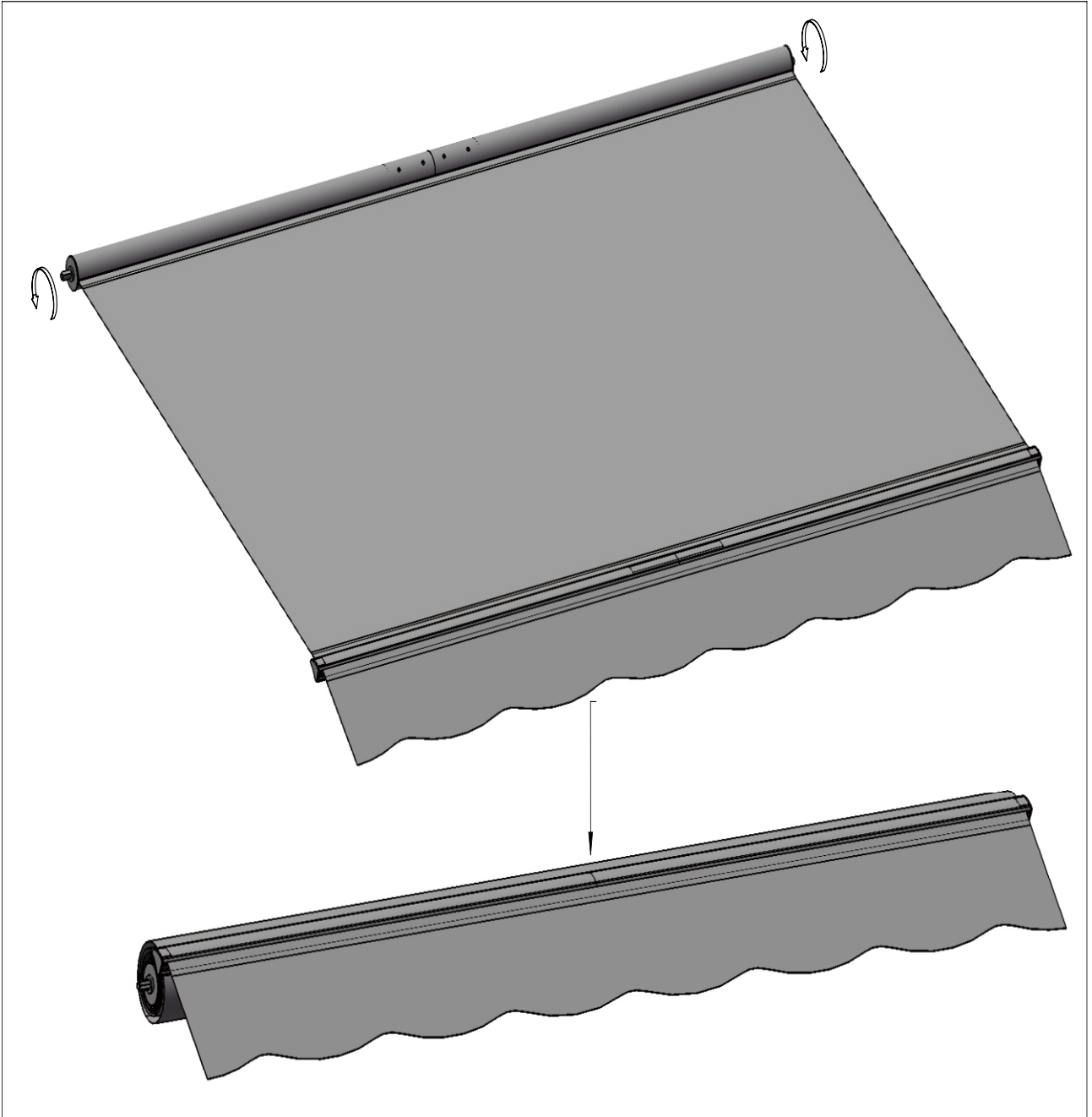

- STEP6:1.Connecting the Torsionbar, and screwed it later  
2.Put the Roller into the square hole of the gear box and Round Square of the roller support  
3.Connect the two torsion bar

# Insertin

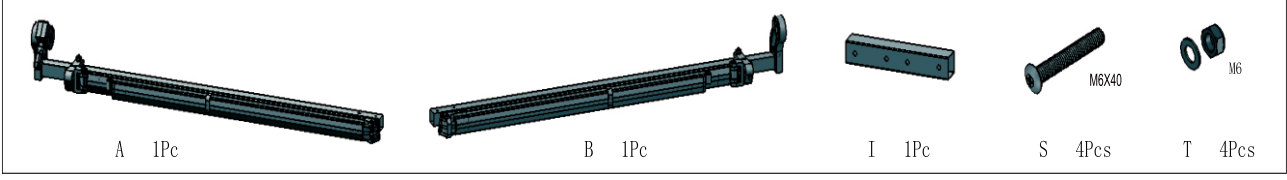
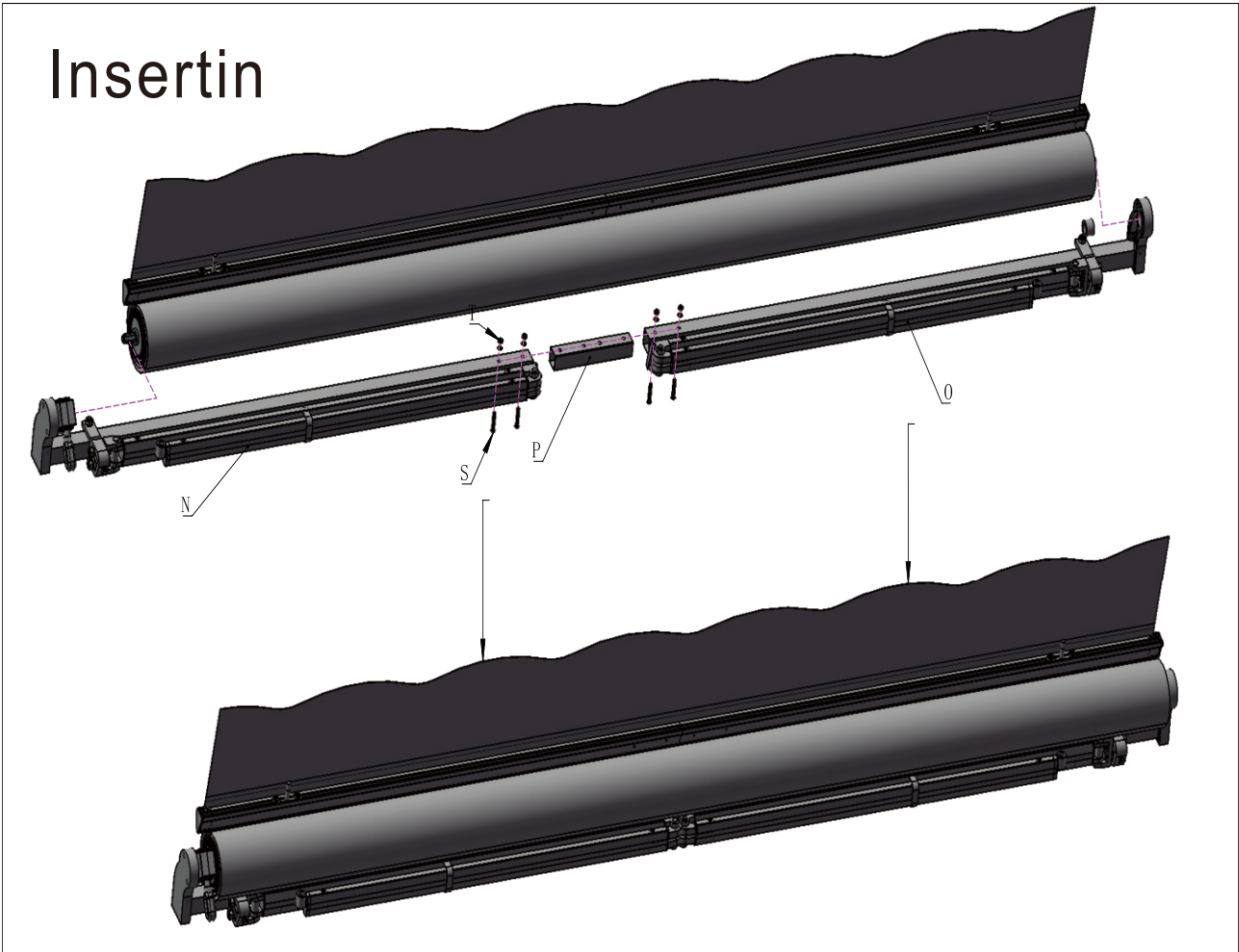

STEP7:Setting Awning Position

- 1.Move the arm-Link until the front bar wrist suppre is Connected throught it.
- 2.Align the from bar and the arm. and tighten the screw O part
- 3.Then tighten U the adjustable bolt up to 90% tight

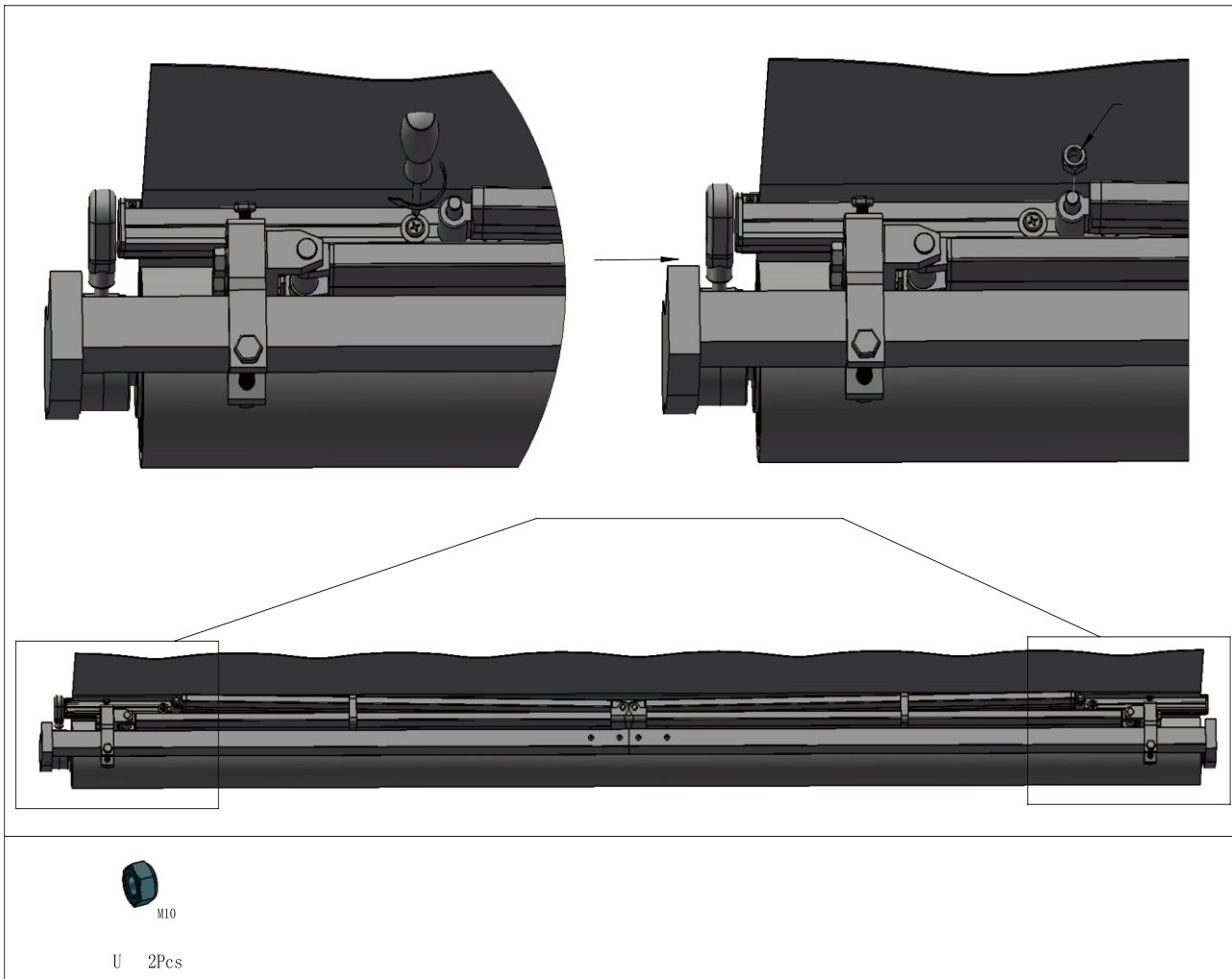

**STEP8: Finishing Awning Assembly**

1. It's safe to cut the safety sleeves that hold the arms and torsion bar down. Awning assembly is complete.
2. Now, Proceed to the wall mounting section.

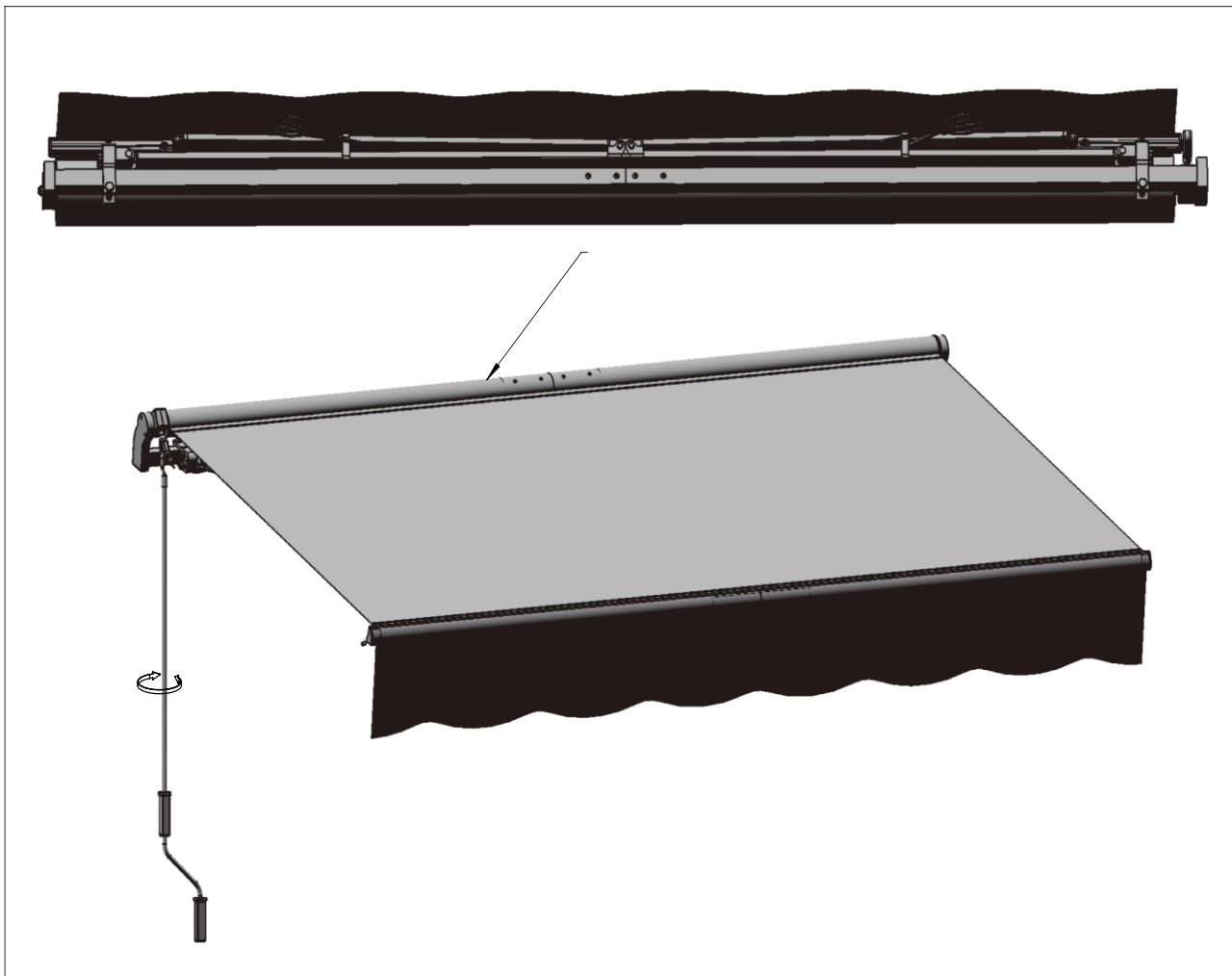

## INSTALLATION

### Notes About Wall Mounting

This awning can be secured to reinforced concrete, brick, and wood, however this awning kit only supplies screws suitable for mounting to brick and reinforced concrete walls.

If you wish to secure your awning to wood, please use carriage bolts of adequate length and of an appropriate diameter to secure the awning to wood beams. The bolt size depends on the size of wood; these can be purchased at a hardware store. We recommend a professional installer for the safest and most secure installation.

**Never attempt to secure the wall brackets to loose wall stones or any surfaces that are not absolutely firm!**



**CAUTION:** Proper location of the brackets is the most important aspect of the awning installation. It is critical that you fasten all the mounting brackets to studs, joists, headers or other major structural components.



**WARNING:** Failure to securely fasten all the brackets to the wall could result in the collapse of the awning and cause personal injury or death.

### Mounting Height

It is important to take the awning's drop area into consideration before bolting your wall mounts. If you would like to mount above a patio door, for example, please leave at least 8 inches above the door frame and be sure that the awning does not interfere with opening and closing the door. The drop angle can only be changed minimally, so take this into consideration when deciding where to place your awning.

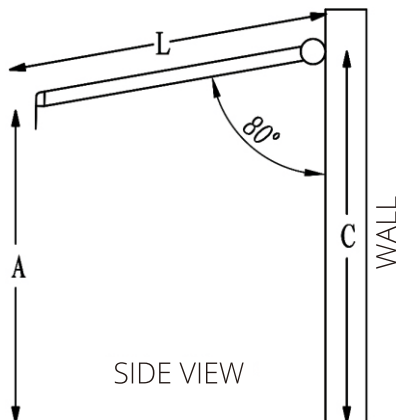

*We recommend that the awning surface make an angle of about 80 degrees to the wall when open.*

- **Recommended Installation Height:** 8-12 feet.
- **The ideal drop angle (when fully extended) has already been set in the factory,** so you may not have to change the pitch/angle.
- **The awning has a drop** of 24 inches when at a slope, or 15 degrees.

#### CALCULATIONS:

You can use the following formula to calculate the appropriate angle.

$$C = A + 0.17 * L$$

A = The desired height of the front bar

L = The length of the arm stretched out

C = The height of the wall brackets

## STEP 1: Measuring the Mount Site

1. Measure the length of your awning along the wall where you intend to install it. This line will be the highest point of your awning and align with the top of the wall bracket. Use a leveler to make a chalk line across the distance.
2. **Important: double check that the line is level all the way across.**
3. Be sure that the line is centered over the patio door, window, or other feature, if applicable.
4. Now that you have a straight, centered line, measure the middle point and mark it. This is where the middle wall bracket will be installed.
5. Take a wall bracket and place the top of it, completely level, under the line, as shown in the diagram below. With chalk or a pencil, mark the position of all the wall brackets and their bolt holes.

Awnings < 10.8 Feet	Requires only 2 wall brackets total: one for each end of the torsion bars.
Awnings 10.8 - 14 Feet	Requires 3 wall brackets total: one for each end, and one in the middle.
Awnings 14.5 - 20 Feet	Requires 4 wall brackets total: one for each end, and two in the middle.

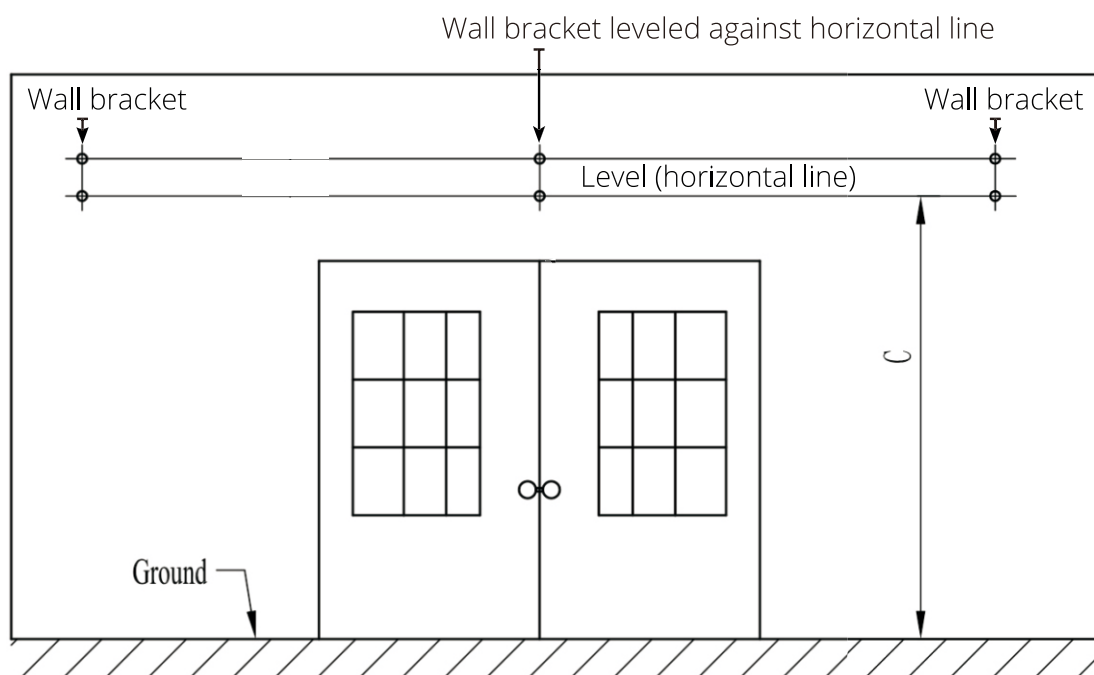

## STEP 2: Drilling the Bolt Holes

1. Now that you have a straight, level line across the wall with the locations of the wall brackets and their bolt holes marked, you will drill holes to mount the brackets.
2. Using a 14mm masonry drill bit, drill the first bolt hole approximately 4 inches (9 centimeters) deep, as shown in the diagram. This must be drilled through solid brick or concrete to offer the necessary support for the awning.
3. Drill the remaining holes exactly as in step 2.

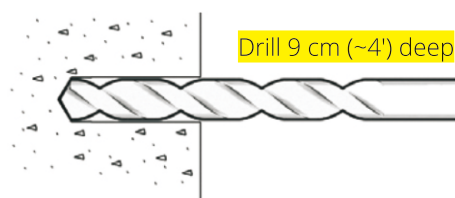

**!! IMPORTANT:** All bolt holes must be aligned vertically and horizontally to ensure that the awning hangs straight.  
**Double check alignment before drilling if you are not certain.**

**!! IMPORTANT:** The diameter and depth of your mounting holes must be the same size as the expansion bolts.

### STEP 3: Preparing For Mounting

1. Now that all of your holes are drilled, insert the expansion bolts.
2. It may be necessary to drive the bolts in with a wooden (or other non-metallic) mallet.



*If a mallet is necessary for installation, we recommend placing the nut on the screw (loosely) before hammering to avoid damaging the bolt threads.*

3. Make sure that the bolts are firmly in place, yet let them stick out of the wall approximately 1 inch or less - enough that the wall bracket can be installed onto them.
4. Firmly tighten the bolts with a 19mm hex key. It is best to use the hex key with a closed end rather than an open end to avoid damaging the nut, should it slip.

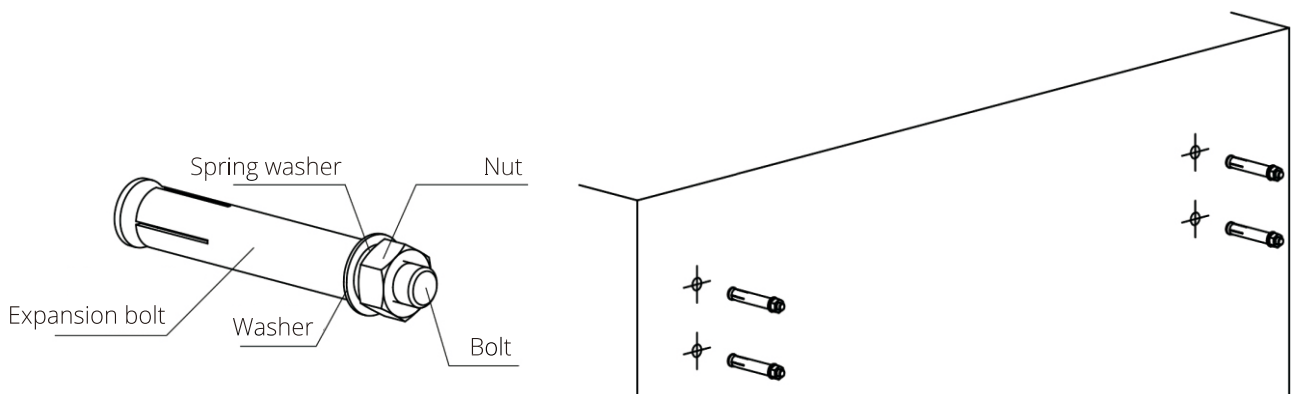

### STEP 4: Mounting the Wall Brackets

1. Now that the bolts are securely in the wall, remove the nuts that are loosely placed over the bolts.
2. Place a wall bracket onto one set of bolts. This should be an easy fit if the bolt holes are properly aligned.
3. Once the wall bracket is resting on the bolts, place a washer over the bolt, then secure it with a nut, as shown in the diagram.
4. The **brackets MUST sit firmly on the wall**. If there is any movement, you must tighten it more.
5. Repeat this step for each of the wall brackets. Once you do this, all wall brackets will be securely in place.

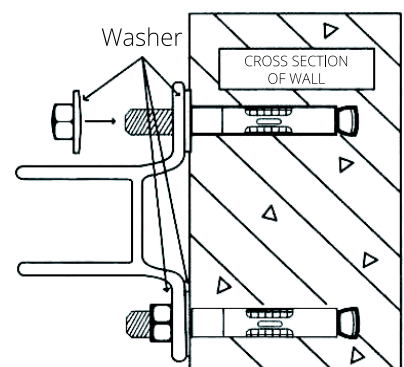

## STEP 5: Mounting the Awning

1. Now that the wall brackets are secure and in place, it is time to install the awning onto the brackets.
2. At least two ladders or sturdy chairs are required to install the awning.
3. Put the original expansion bolts on the wall brackets and tighten them.
4. Finally, fasten all expansion bolts.
5. Using the hand crank or a motor (if applicable), fully open your awning. The front bar should be level.
6. **Congratulations! Your awning is installed. If you are happy with the height of the front bar (awning pitch), sit back and enjoy! If not, please read on.**

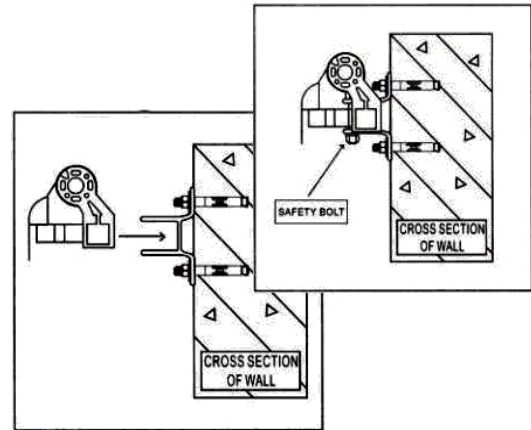

## 😊 OPTIONAL INSTALLATION

### ADJUSTING THE AWNING PITCH/ANGLE

Each awning comes with a pre-set pitch (angle) that is considered ideal. However, if you need to make an adjustment, it can be done in just a few easy steps.

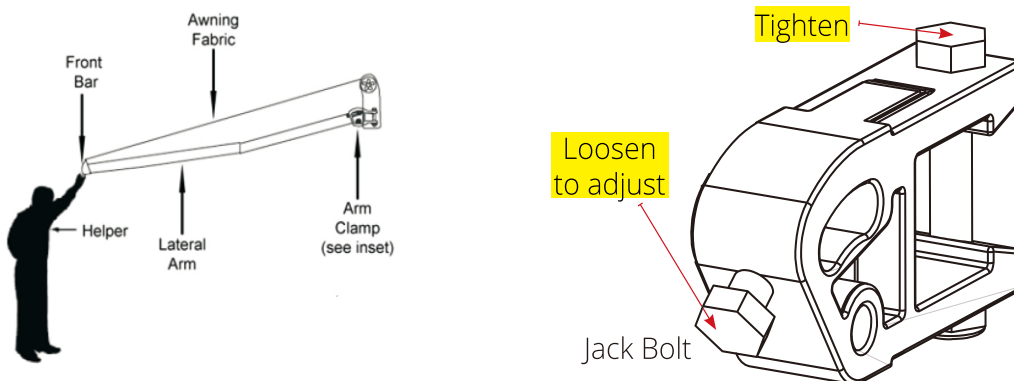

**!! IMPORTANT:** Raising the front bar will reduce the pitch (angle) of the fabric, thus increasing the risk of rain water pooling on the fabric. To prevent the awning from collapsing due to rain water weight, you must retract the awning when unattended. Failure to do so could result in a broken awning or personal injury.

Note: Be sure that the front bar is adjusted to be completely even. Any misalignment will result in improper retraction.

Common mistakes

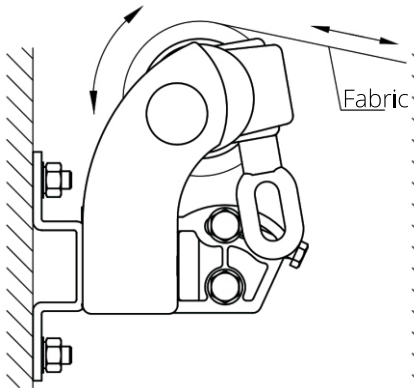

Correct operation

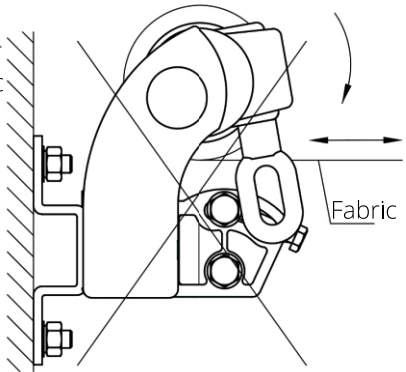

Wrong operation

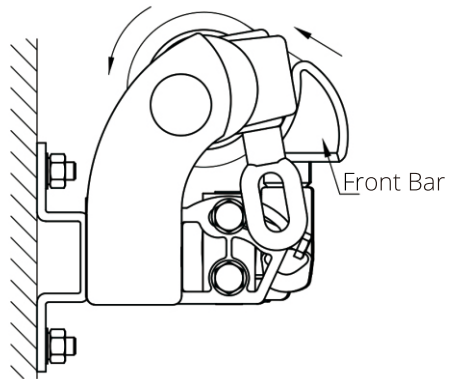





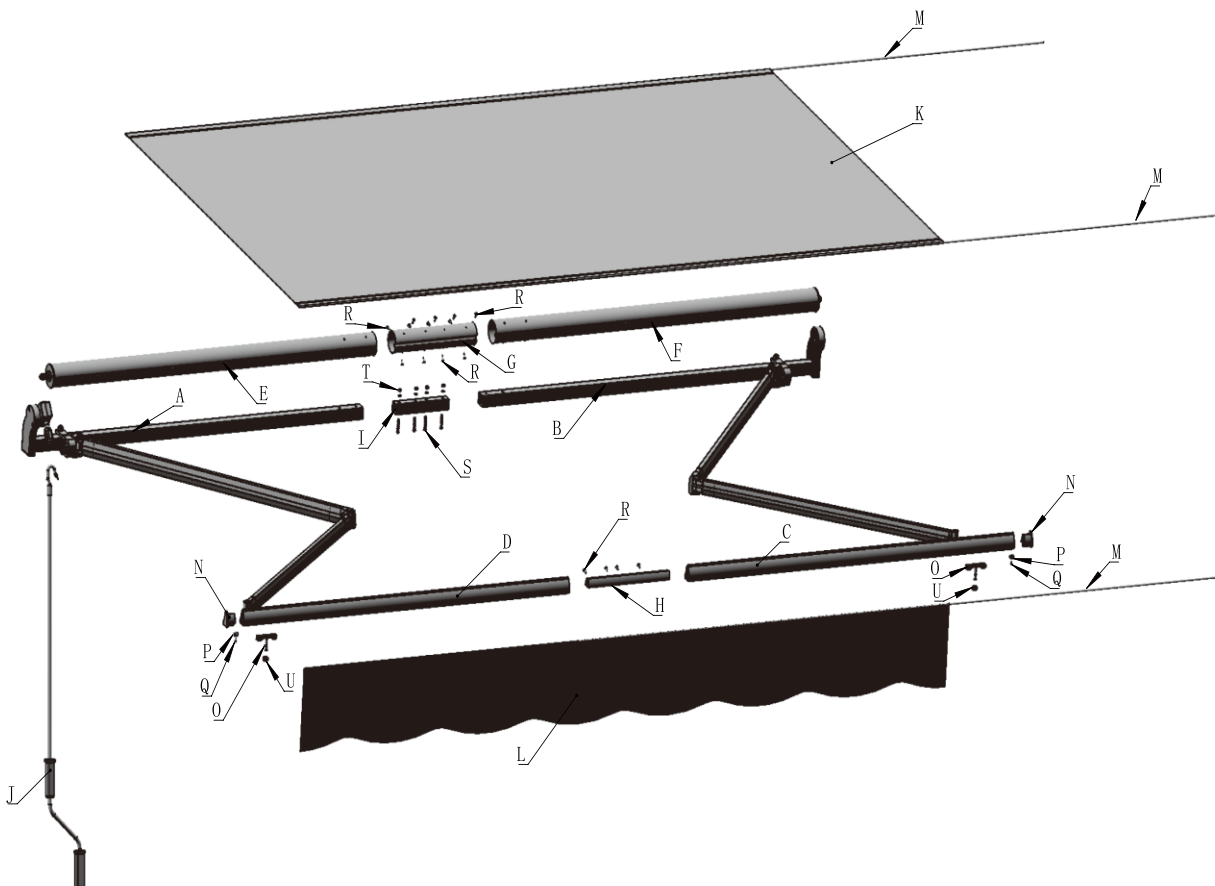



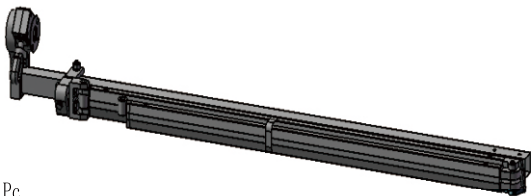
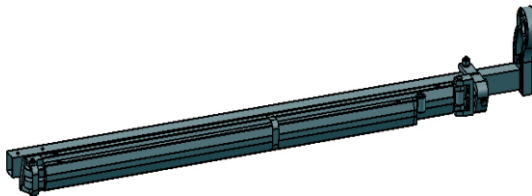



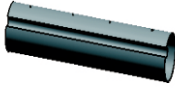

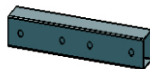

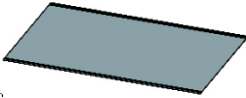





WARNING: When the front bar touches the roller as shown in the figure, don't try to make them closer, otherwise the product may be damaged.

- A. Barre de torsion avec bras (gauche)
- B. Barre de torsion avec bras (droite)
- C. Barre frontale (droite)
- D. Barre frontale (gauche)
- E. Rouleau (gauche)
- F. Rouleau (droit)
- G. Connecteur de rouleau
- H. Connecteur de barre frontale
- I. Connecteur de la barre de torsion
- J. Manivelle
- K. Tissu
- L. Valence
- M. Doublure en tissu
- N. Capuchons de barre frontale (gauche et droite)
- O. Lien Ambar
- P. Boulon en plastique pour le couvercle et le doublure en tissu
- Q. St 3x10
- R. St 14x15
- S. M6X40
- T. M6
- U. M10
- V. M8X55
- W. M8
- X. Vis d'expansion
- Y. Supports muraux

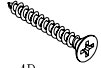

LISTE DES PIÈCES

 <p>A 1Pc</p>		 <p>B 1Pc</p>					
 <p>C 1Pc</p>		 <p>D 1Pc</p>					
 <p>E 1Pc</p>		 <p>F 1Pc</p>					
 <p>G 1Pc</p>	 <p>H 1Pc</p>	 <p>I 1Pc</p>	 <p>J 1Pc</p>				
 <p>K 1Pc</p>	 <p>L 1Pc</p>	 <p>M 3Pc</p>	 <p>N 2Pcs</p>	 <p>O 2Pcs</p>			
 <p>P 2Pcs</p>	 <p>Q 2Pcs</p>	 <p>R 16Pcs</p>	 <p>S 4Pcs</p>	 <p>T 4Pcs</p>	 <p>U 2Pcs</p>	 <p>V 2Pcs</p>	 <p>W 2Pcs</p>
 <p>X 4Pcs</p>	 <p>Y 2Pcs</p>	 <p>Z 4Pcs</p>					

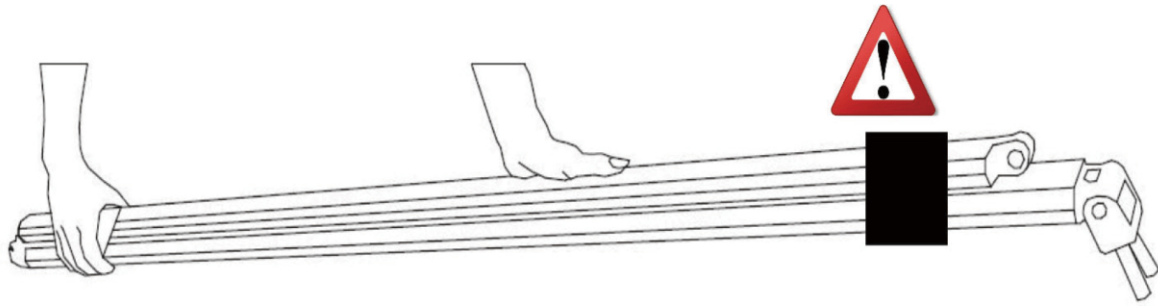

**AVERTISSEMENT  
LES BRAS DE L'AUVENT PEUVENT  
PROVOQUER DES BLESSURES**

**NE COUPER LES RUBANS DES BRAS DE L'AUVENT  
QU'UNE FOIS L'AUVENT COMPLETEMENT MONTÉ**

- ÉQUIPE ALEKO

**X** mauvais



**✓** correct



**AVERTISSEMENT  
CAUSE DES BLESSURES !  
NE COUPER QU'UNE FOIS L'AUVENT ENTIÈREMENT MONTÉ**

ÉTAPE 1 : Enfiler la ligne de tissu, et couper la ligne de tissu de la même longueur que le tissu.

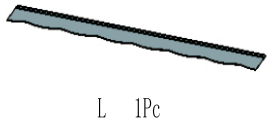
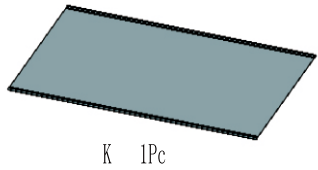
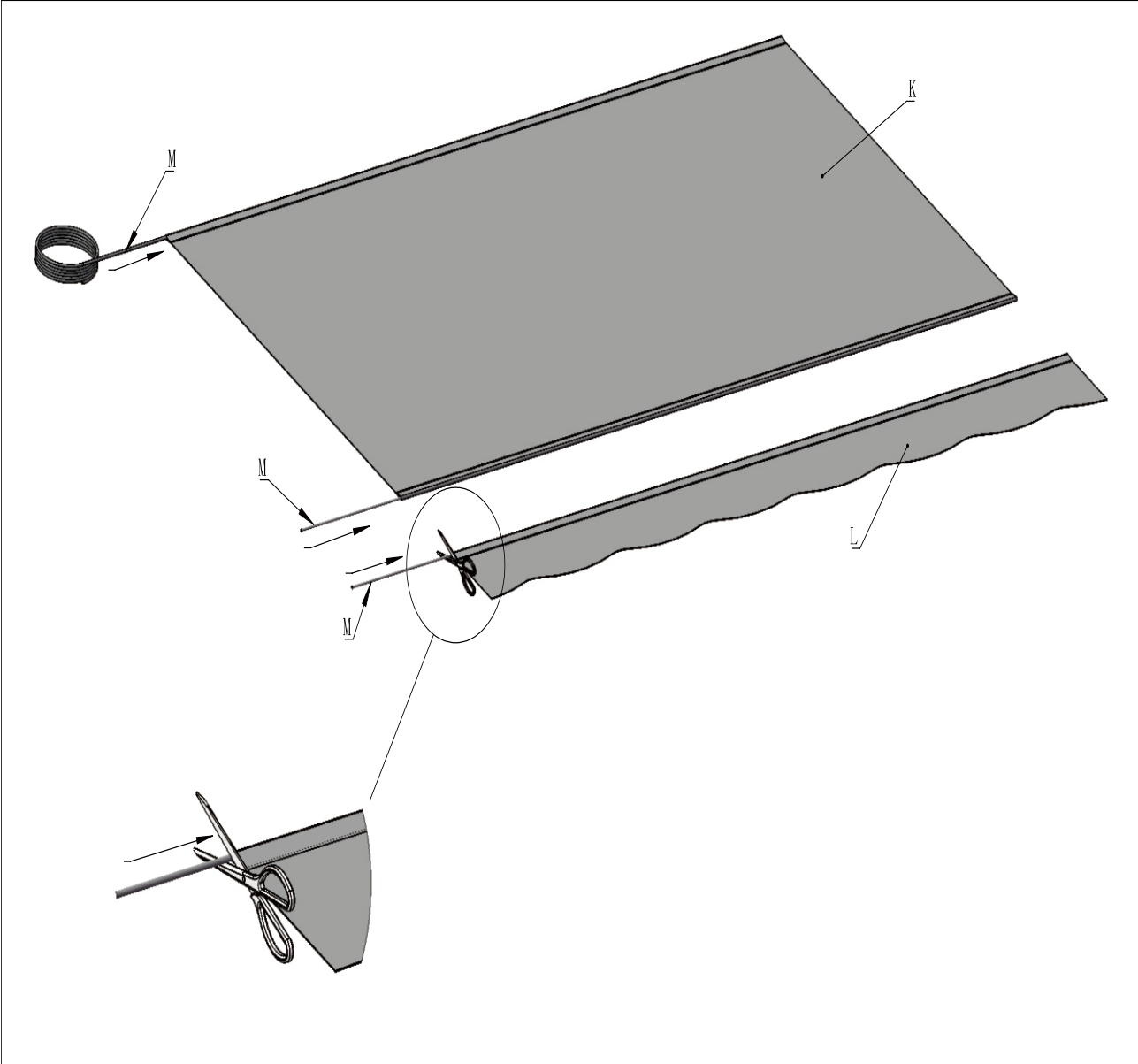



ÉTAPE 3 : Assemblage du tissu et connexion du rouleau et de la barre frontale

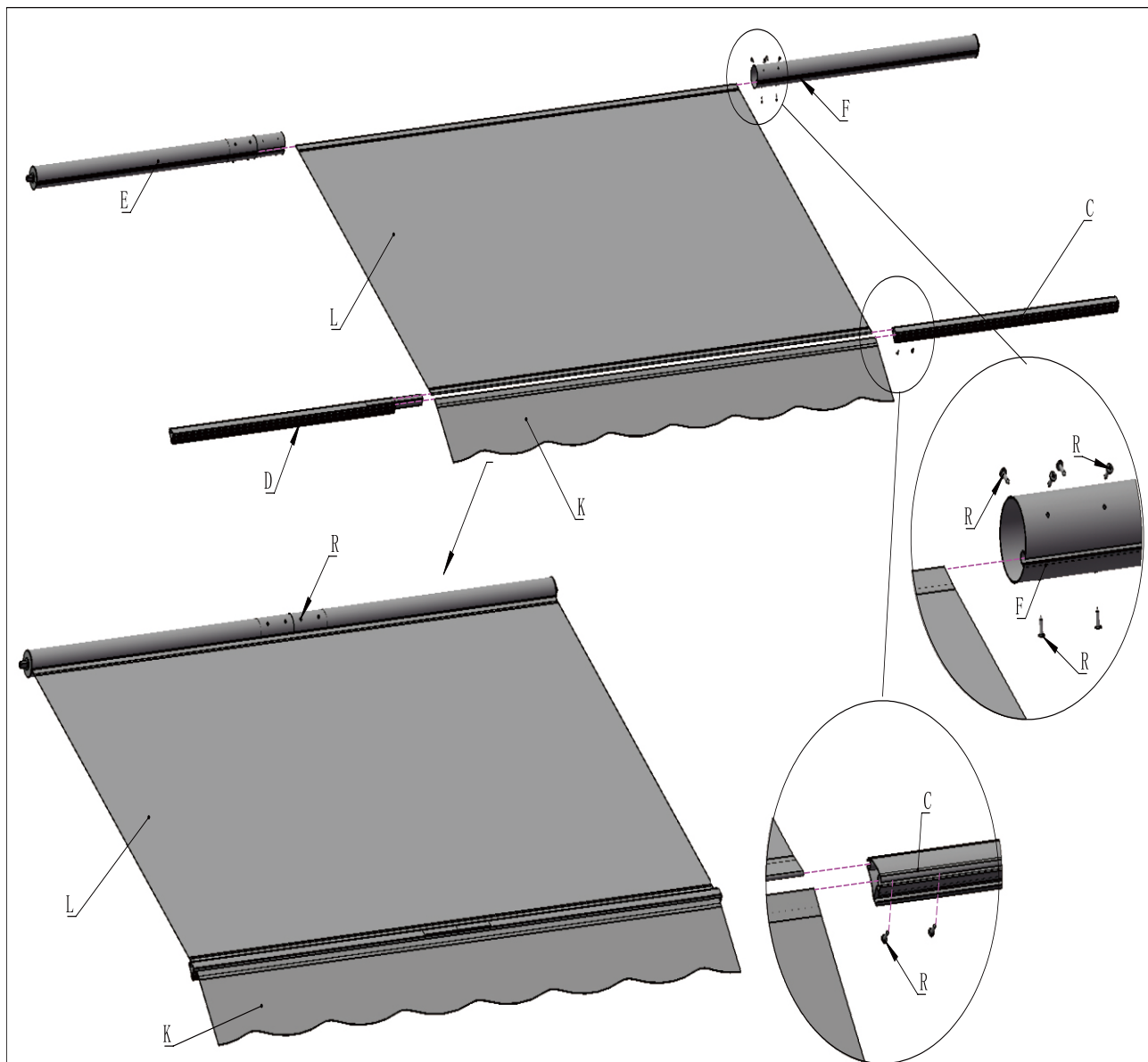

- C 1Pc
  - F 1Pc
  - R 8Pcs
- S4X15

- ÉTAPE 4 : 1. Placer le lien de la barre de bras dans la barre frontale  
2. Placer la partie P dans la barre frontale et la verrouiller avec la vis Q  
3. Fixer fermement les capuchons de la barre frontale

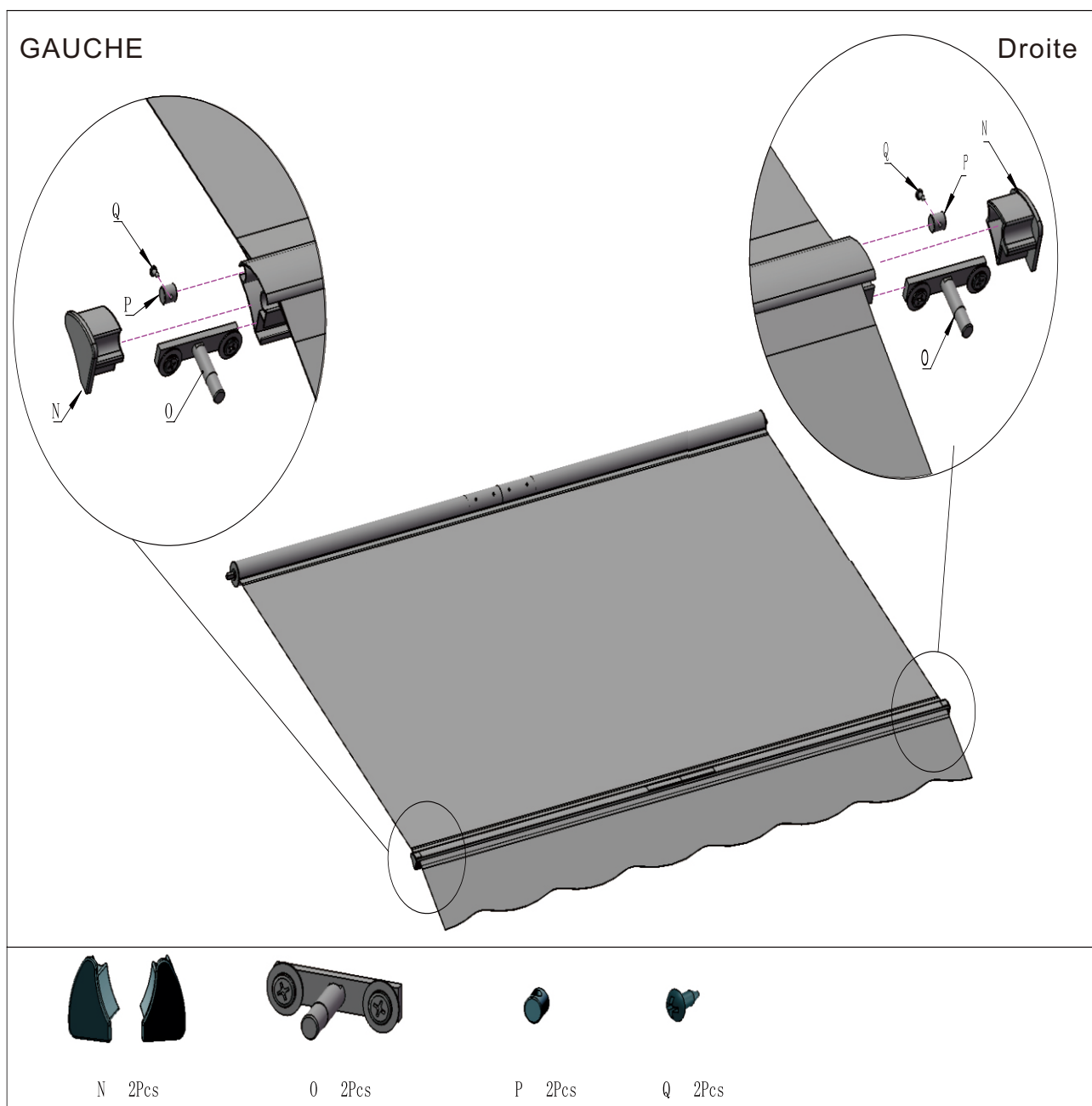

ÉTAPE 5 : Enrouler la toile de l'auvent aussi serré que possible.

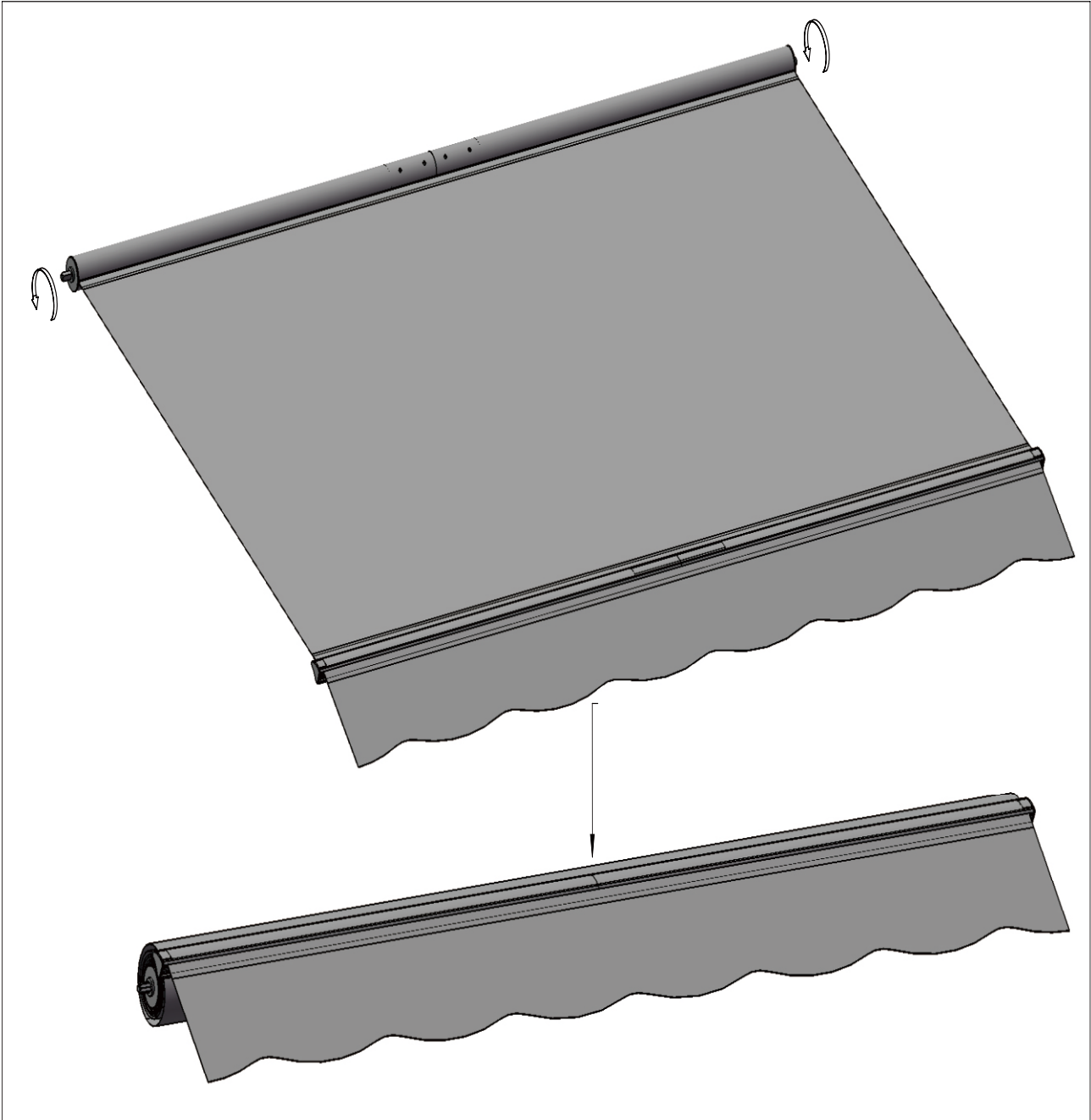

- ÉTAPE 6 : 1. Connecter la barre de torsion et la visser plus tard.  
2. Introduire le rouleau dans le trou carré de la boîte d'engrenage et dans le carré rond du support de rouleau.  
3. Connecter les deux barres de torsion et les visser.

Insérer

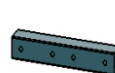
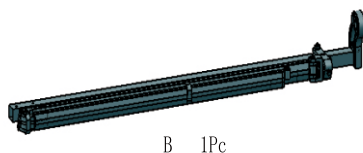
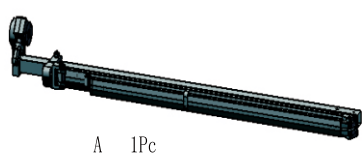
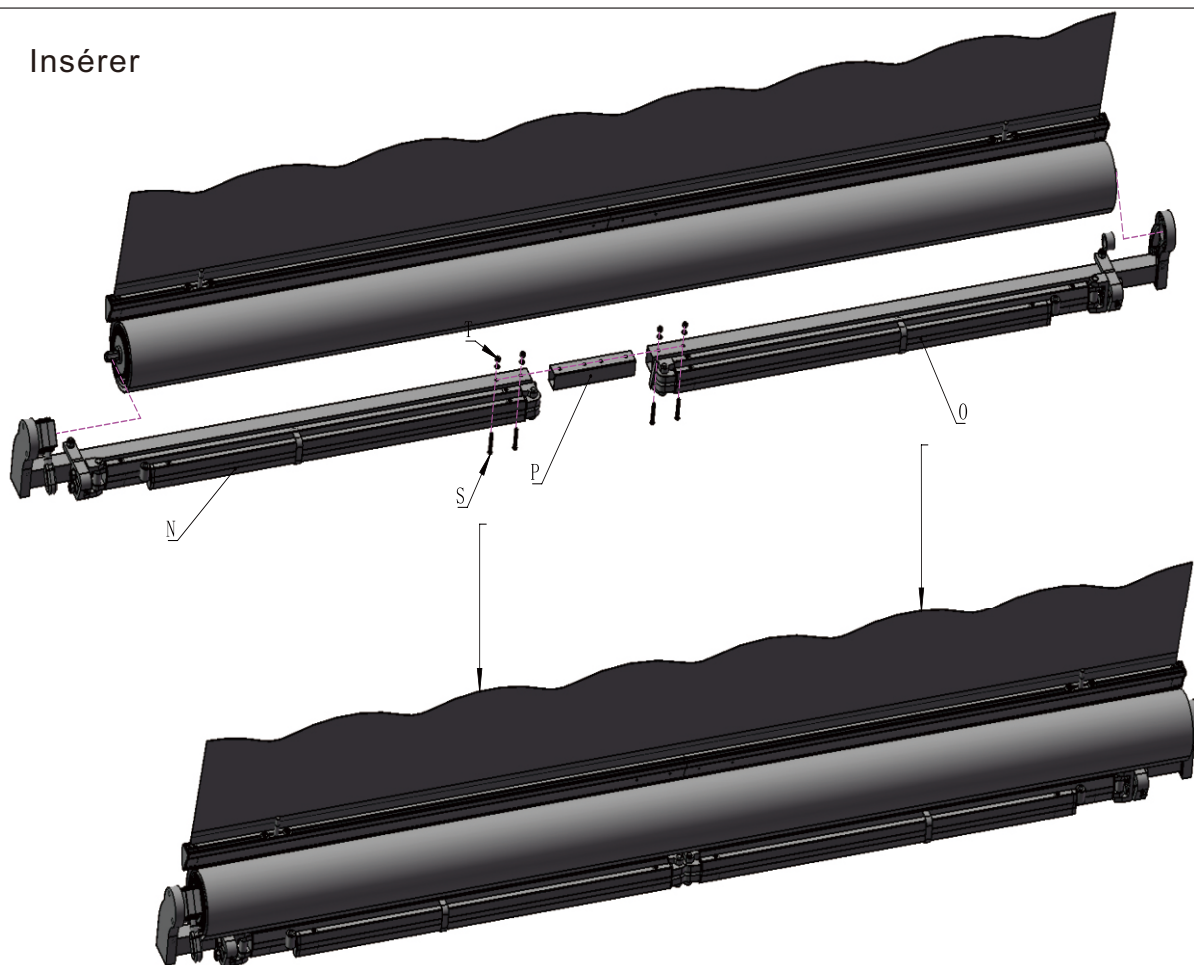

## ÉTAPE 7 : Réglage de la position de l'auvent

1. Faire glisser l'encre du bras jusqu'à ce que le support de poignet de la barre frontale soit connecté à travers elle.
2. Aligner la barre avant et le bras et serrer la vis en O.
3. Serrer ensuite le boulon réglable jusqu'à 90 %

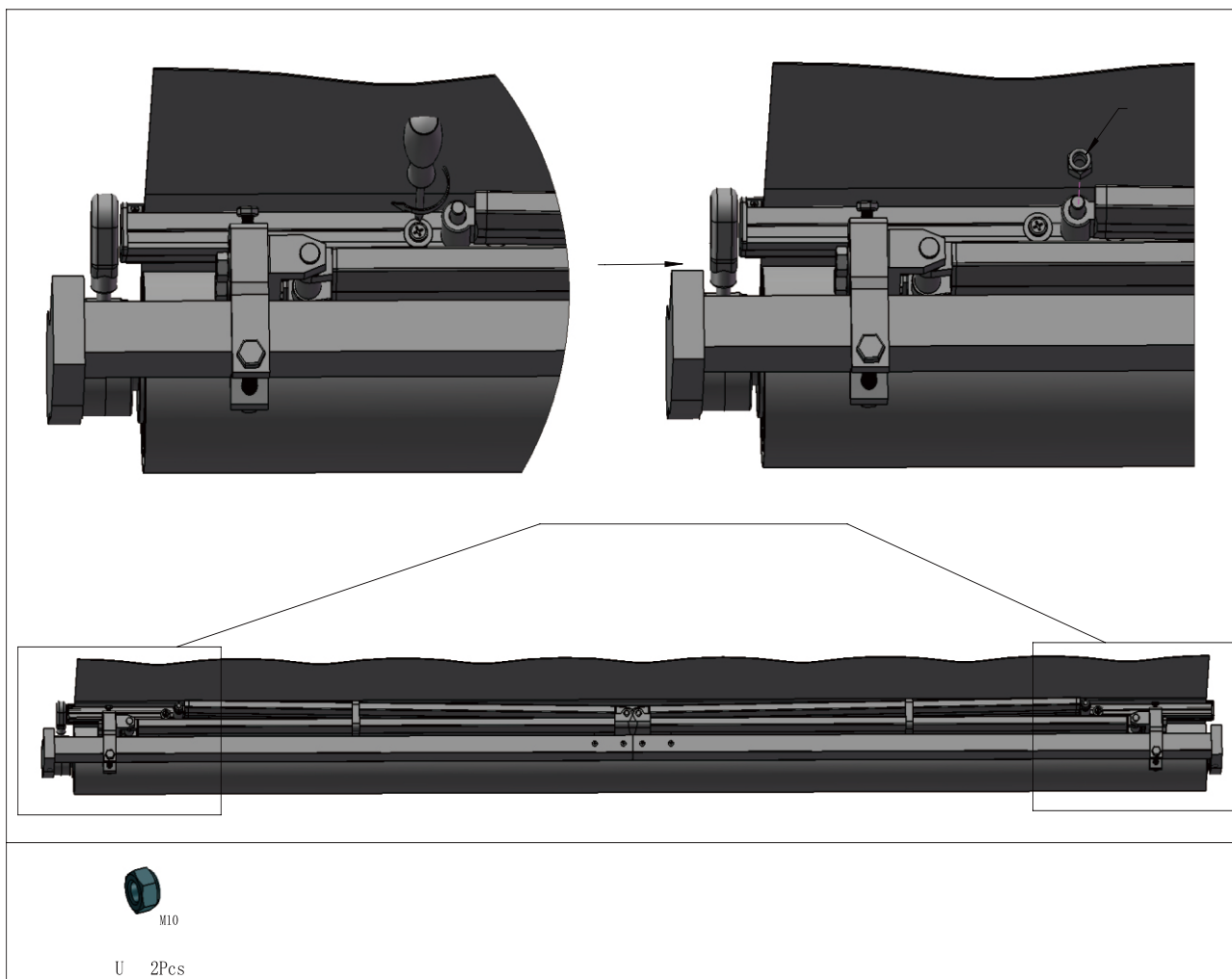

**ÉTAPE 8 : Finalisation de l'assemblage de l'auvent**

1. Il convient de couper les gaines de sécurité qui maintiennent les bras et la barre de torsion vers le bas. Le montage de l'auvent est terminé.
2. Vous pouvez maintenant passer à la section relative au montage mural.

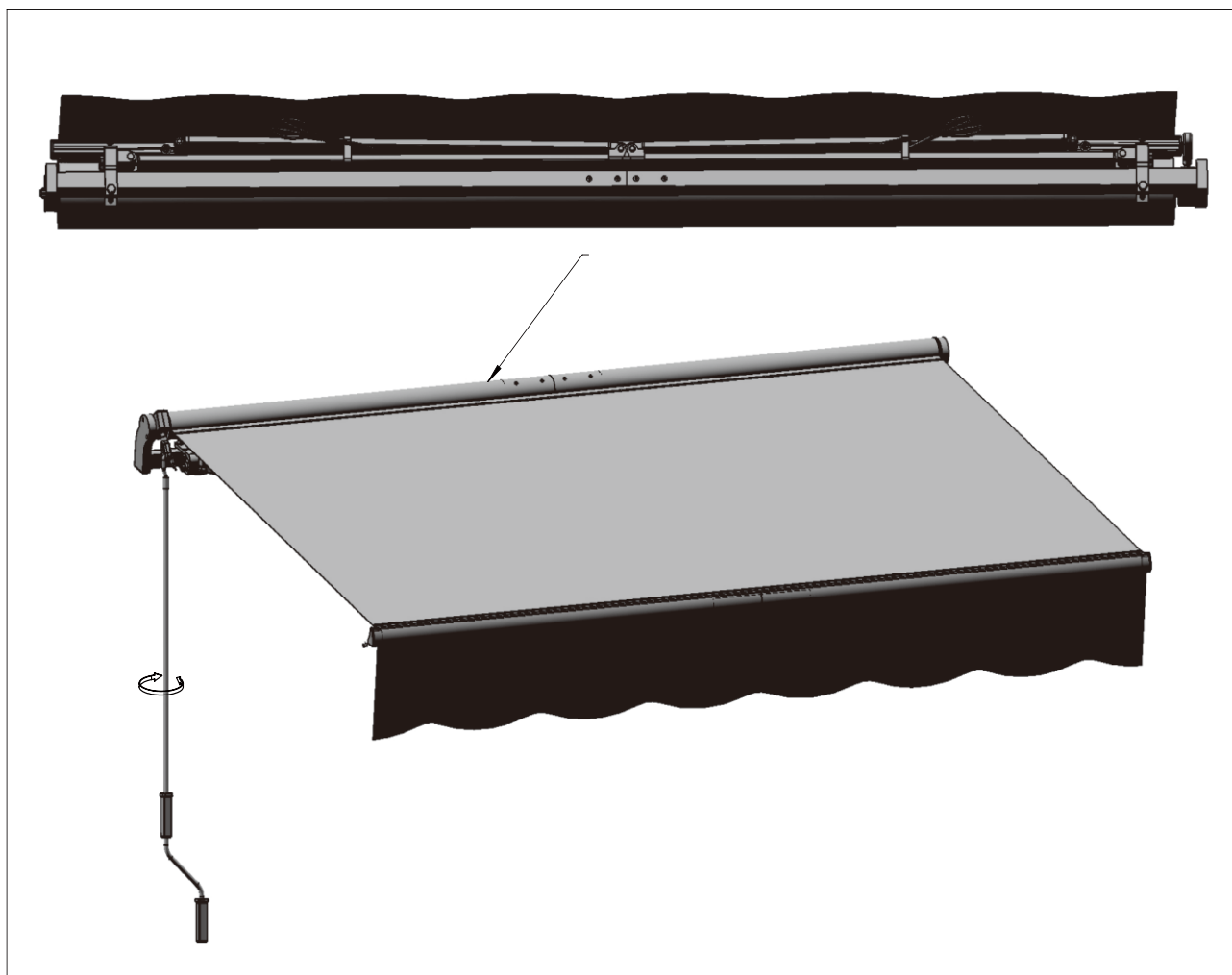

## 🔧 INSTALLATION

### Remarques concernant le montage mural

La fixation de cet auvent peut se faire sur du béton armé, de la brique et du bois. Pour autant, ce kit d'auvent ne comporte que des vis adaptées à la fixation sur des murs en brique et en béton armé.

Pour la fixation de l'auvent sur du bois, veuillez à utiliser des boulons de carrosserie d'une longueur et d'un diamètre suffisants pour fixer l'auvent sur des poutres en bois. La dimension des boulons diffère selon la taille du bois. Ces boulons peuvent être achetés chez un détaillant en quincaillerie. Pour une installation plus sûre, nous vous recommandons de faire appel à un installateur professionnel.

**Il ne faut jamais essayer de fixer les supports muraux à des pierres de taille ou à toute autre surface qui n'est pas absolument ferme !**



**MISE EN GARDE** : la fixation appropriée des supports représente l'aspect le plus important de l'installation. Il est essentiel que vous fixiez plus rapidement tous les supports de montage sur des goujons, des poteaux, des collecteurs ou d'autres éléments structurels importants.



**AVERTISSEMENT** : si tous les supports ne sont pas solidement fixés au mur, l'auvent risque de s'effondrer et de provoquer des blessures corporelles, voire la mort.

### Hauteur de montage

Vous devez tenir compte de la zone de descente de l'auvent avant de visser vos supports muraux. Par exemple, si vous souhaitez installer votre auvent au-dessus d'une porte-fenêtre, laissez un espace d'au moins 8 pouces au-dessus du cadre de la porte et assurez-vous que l'auvent n'interfère pas avec l'ouverture et la fermeture de la porte. Étant donné que l'angle de descente ne peut être modifié que de façon minimale, tenez-en compte lorsque vous décidez de l'emplacement de votre auvent.

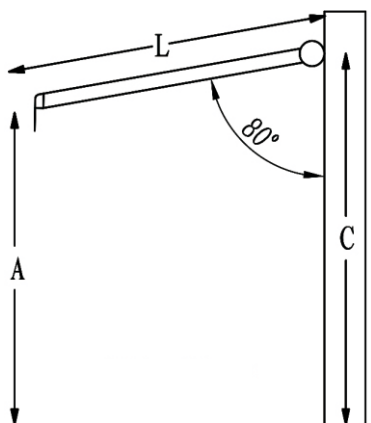

- **Hauteur d'installation recommandée** : 8 à 12 pieds.
- **Nous avons déjà réglé en usine l'angle de descente idéal (lorsque le store est entièrement déployé)**, il est donc possible que vous n'ayez pas à modifier l'inclinaison ou l'angle.
- **L'auvent peut atteindre une descente de 24 pouces à l'inclinaison, soit 15 degrés.**

*En position ouverte, nous vous conseillons d'orienter la surface de l'auvent vers le mur à un angle d'environ 80 degrés.*

### CALCULS :

Pour calculer l'angle approprié, vous pouvez utiliser la formule suivante :

$$C = A + 0,17 * L$$

A = La hauteur souhaitée de la barre frontale

L = La longueur du bras tendu

C = La hauteur des supports muraux

### ÉTAPE 1 : Prise de mesure de l'emplacement de montage

1. Prenez la mesure de la longueur de votre auvent le long du mur où vous avez l'intention de l'installer. Le point le plus haut de votre auvent sera cette ligne, qui s'alignera sur le haut du support mural. À l'aide d'un niveau, tracez une ligne à la craie sur toute la distance.

**2. Important : veillez à ce que la ligne soit bien horizontale sur toute la longueur.**

3. Faites en sorte que la ligne soit centrée par rapport à la porte-fenêtre, à la fenêtre ou à tout autre élément, le cas échéant.

4. Une fois la ligne droite et centrée, mesurez le point central et marquez-le. Le support mural du milieu sera installé à cet endroit.

5. Prenez un support mural et placez sa partie supérieure, parfaitement à niveau, sous la ligne, comme le montre le schéma ci-dessous. Utilisez une craie ou un crayon pour marquer la position de tous les supports muraux et leurs trous de fixation.

Auvents < 10,8 pieds	Ne nécessite que 2 supports muraux au total : un pour chaque extrémité des barres de torsion.
Auvents de 10,8 à 14 pieds	Il faut 3 supports muraux au total : un pour chaque extrémité et un au milieu.
Auvents de 14,5 à 20 pieds	Il faut 4 supports muraux au total : un pour chaque extrémité et deux au milieu.

Fixation murale nivelée par rapport à la ligne horizontale

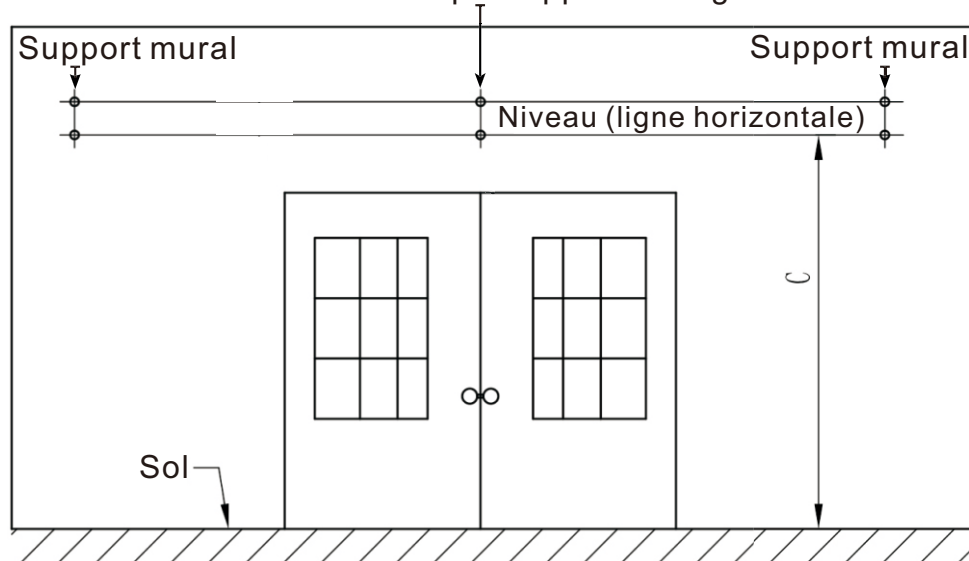

### ÉTAPE 2 : Perçage des trous de fixation

1. Après avoir tracé une ligne droite et horizontale sur le mur et marqué l'emplacement des supports muraux et de leurs trous de fixation, vous allez maintenant percer les trous pour monter les supports.

2. À l'aide d'une mèche à maçonnerie de 14 mm, percez le premier trou de fixation à une profondeur d'environ 9 centimètres (4 pouces), comme indiqué sur le schéma. Il faut percer à travers une brique solide ou du béton pour offrir le support nécessaire à l'auvent.

3. Procédez de la même manière qu'à l'étape 2 pour percer les autres trous.

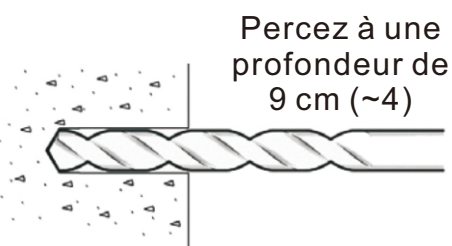

**!! IMPORTANT** : Il faut aligner tous les trous des boulons verticalement et horizontalement pour que l'auvent soit bien suspendu.  
**Si vous n'êtes pas sûr, vérifiez l'alignement avant de percer.**

**!! IMPORTANT** : les trous de montage doivent avoir le même diamètre et la même profondeur que les boulons d'expansion.

### ÉTAPE 3 : Préparation du montage

1. Après avoir percé tous les trous, insérez les boulons d'expansion.
2. Vous devrez peut-être enfoncer les boulons à l'aide d'un maillet en bois (ou d'un autre outil non métallique).



*Si vous devez utiliser un maillet pour l'installation, nous vous recommandons de placer l'écrou sur la vis (sans le serrer) avant d'enfoncer le maillet afin d'éviter d'endommager le filetage du boulon.*

3. Faites en sorte que les boulons soient fermement en place, tout en les laissant dépasser du mur d'environ 1 pouce ou moins - suffisamment pour que le support mural puisse être installé dessus.
4. Serrez fermement les boulons à l'aide d'une clé hexagonale de 19 mm. Mieux vaut utiliser une clé hexagonale à bout fermé plutôt qu'à bout ouvert pour éviter d'endommager l'écrou s'il venait à glisser.

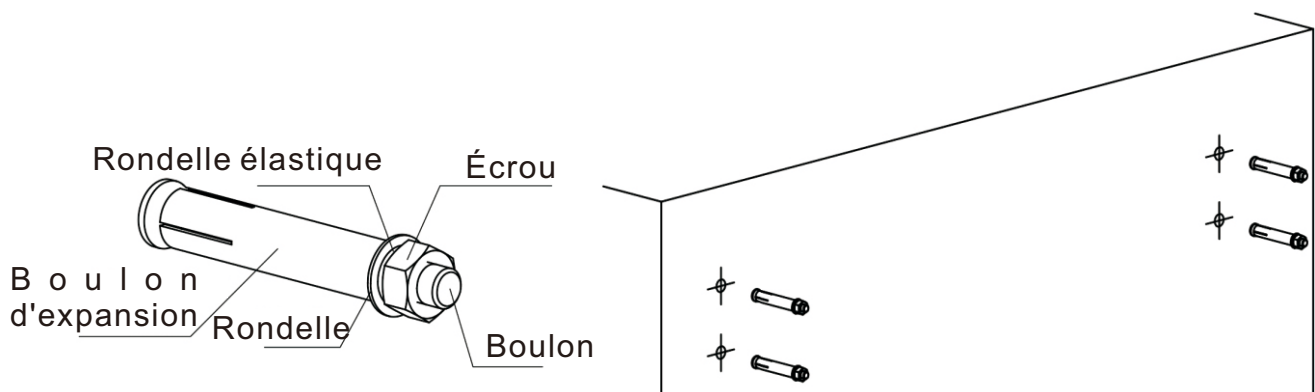

### ÉTAPE 4 : Montage des supports muraux

1. Une fois les boulons solidement ancrés dans le mur, retirez les écrous qui les recouvrent sans les serrer.
2. Placez un support mural sur un jeu de boulons. Le montage devrait être facile si les trous des boulons sont correctement alignés.
3. Après avoir posé le support mural sur les boulons, mettez une rondelle sur le boulon, puis fixez-la à l'aide d'un écrou, comme le montre le schéma.
4. **La fixation DOIT être fermement ancrée au mur.** Si un mouvement se produit, vous devez serrer davantage.
5. Il faut répéter cette étape pour chacun des supports muraux. Une fois cette opération effectuée, tous les supports muraux sont bien en place.

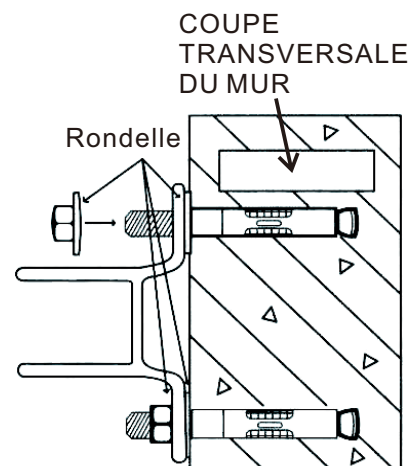

## ÉTAPE 5 : Montage de l'auvent

1. Une fois les supports muraux bien en place, il est temps d'installer l'auvent sur les supports.
2. Deux échelles au moins ou des chaises robustes sont nécessaires pour installer l'auvent.
3. Insérez les boulons d'expansion d'origine sur les supports muraux et serrez-les.
4. Pour terminer, fixez tous les boulons d'expansion.
5. Ouvrez complètement votre auvent à l'aide de la manivelle ou d'un moteur (le cas échéant). La barre frontale doit être nivelée.
6. **Vous voilà rassuré ! Votre auvent est installé. Si la hauteur de la barre frontale (inclinaison de l'auvent) vous convient, vous pouvez vous asseoir et profiter de l'auvent ! Si vous n'êtes pas satisfait, veuillez lire ce qui suit.**

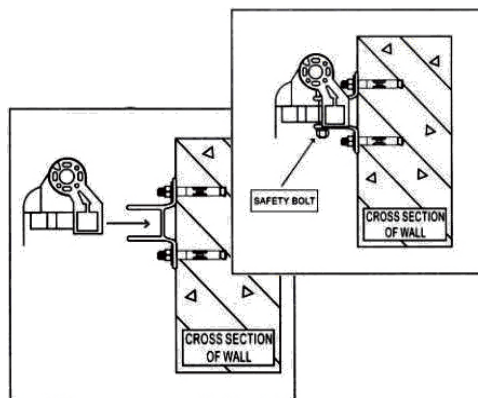

## ☺ INSTALLATION OPTIONNELLE

### RÉGLAGE DE L'INCLINAISON DE L'AUVENT

Tous les auvents sont livrés avec une inclinaison (un angle) prédéfinie, considérée comme idéale. Si toutefois vous avez besoin d'effectuer un réglage, vous pouvez le faire en quelques étapes simples.

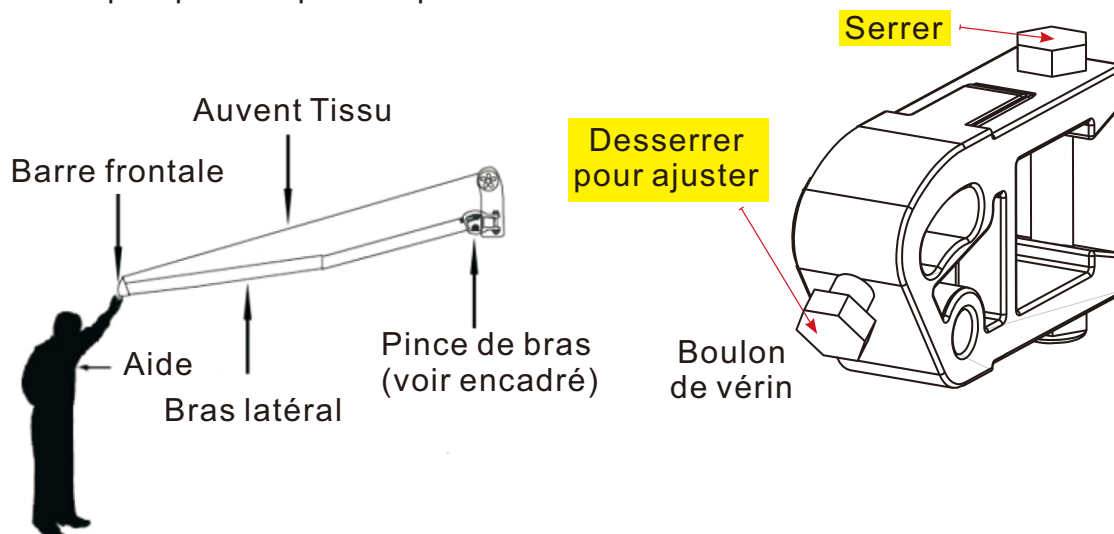

**!! IMPORTANT :** Le fait de remonter la barre frontale va réduire l'inclinaison (l'angle) de l'auvent, augmentant ainsi le risque de polissage de la toile par l'eau de pluie. Vous devez attacher l'auvent lorsqu'il est surveillé afin d'éviter qu'il ne s'effondre sous l'effet du poids de l'eau de pluie. Si vous ne respectez pas cette consigne, vous risquez de casser l'auvent ou de vous blesser.



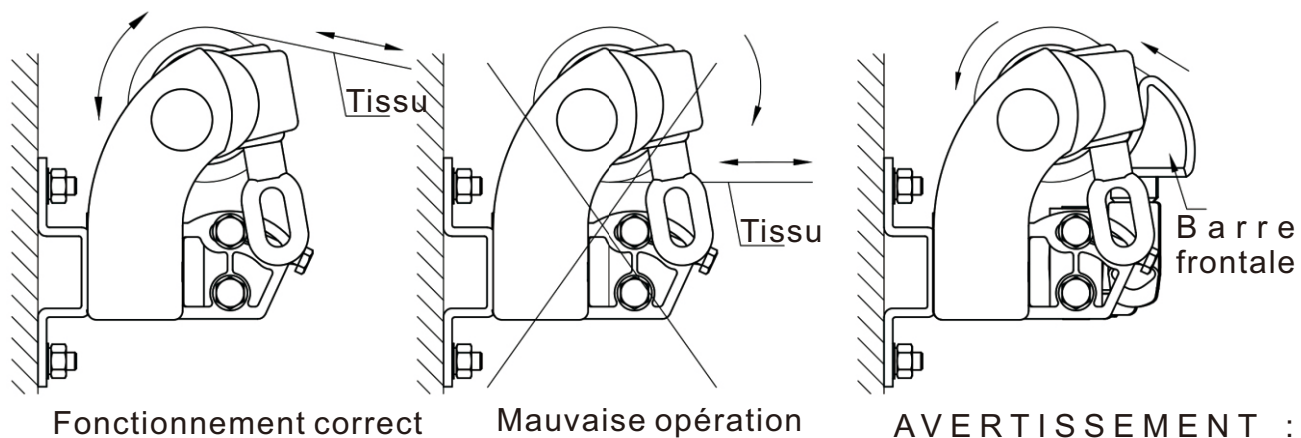







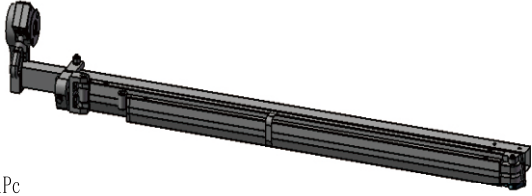
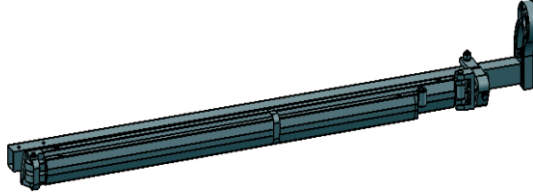

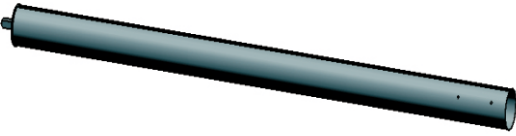
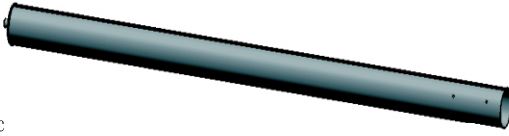
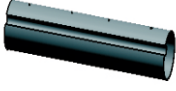

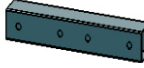

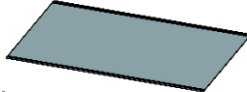



Remarque : veuillez à ce que la barre frontale soit réglée de manière à être parfaitement plane. Tout défaut d'alignement entraînera une mauvaise rétraction.

**Erreurs courantes**

**AVERTISSEMENT :**  
lorsque la barre frontale  
touche le rouleau comme  
le montre la figure,  
n'essayez pas de les  
rapprocher, sinon le  
produit risque d'être  
endommagé.

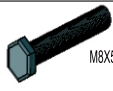

LISTA DE PIEZAS

 <p>A 1Pc</p>		 <p>B 1Pc</p>					
 <p>C 1Pc</p>		 <p>D 1Pc</p>					
 <p>E 1Pc</p>		 <p>F 1Pc</p>					
 <p>G 1Pc</p>	 <p>H 1Pc</p>	 <p>I 1Pc</p>	 <p>J 1Pc</p>				
 <p>K 1Pc</p>	 <p>L 1Pc</p>	 <p>M 3Pc</p>	 <p>N 2Pcs</p>	 <p>O 2Pcs</p>			
 <p>P 2Pcs</p>	 <p>Q 2Pcs</p>	 <p>R 16Pcs</p>	 <p>S 4Pcs</p>	 <p>T 4Pcs</p>	 <p>U 2Pcs</p>	 <p>V 2Pcs</p>	 <p>W 2Pcs</p>
 <p>X 4Pcs</p>	 <p>Y 2Pcs</p>	 <p>Z 4Pcs</p>					

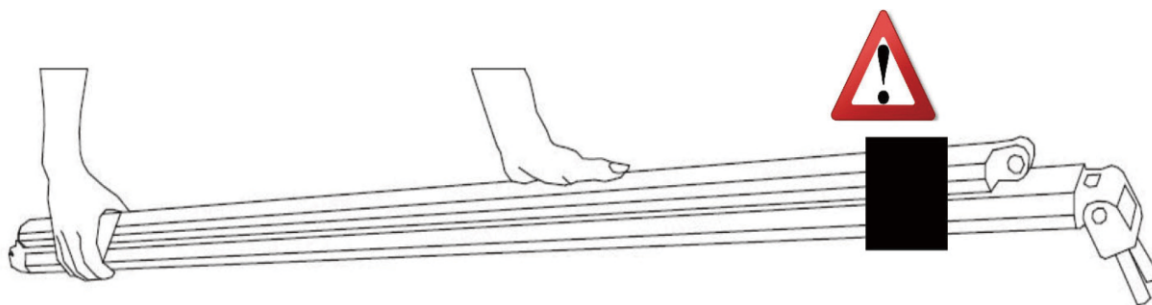

**¡ATENCIÓN!  
¡LOS BRAZOS DEL TOLDO PUEDEN CAUSAR LESIONES!**

**CORTE LAS CINTAS DE LOS BRAZOS DEL TOLDO SÓLO DESPUÉS DE QUE EL TOLDO ESTÉ COMPLETAMENTE MONTADO**

**X** Equivocado



**✓** Correcto



**AVISO**  
**¡PUEDE CAUSAR LESIONES!**  
**SÓLO CORTE DESPUÉS DE COMPLETAMENTE MONTADO**

PASO 1: Enhebre el hilo en la tela y córtelo del mismo largo que la tela.

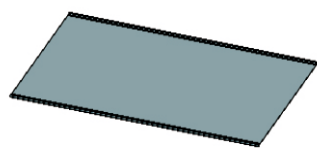
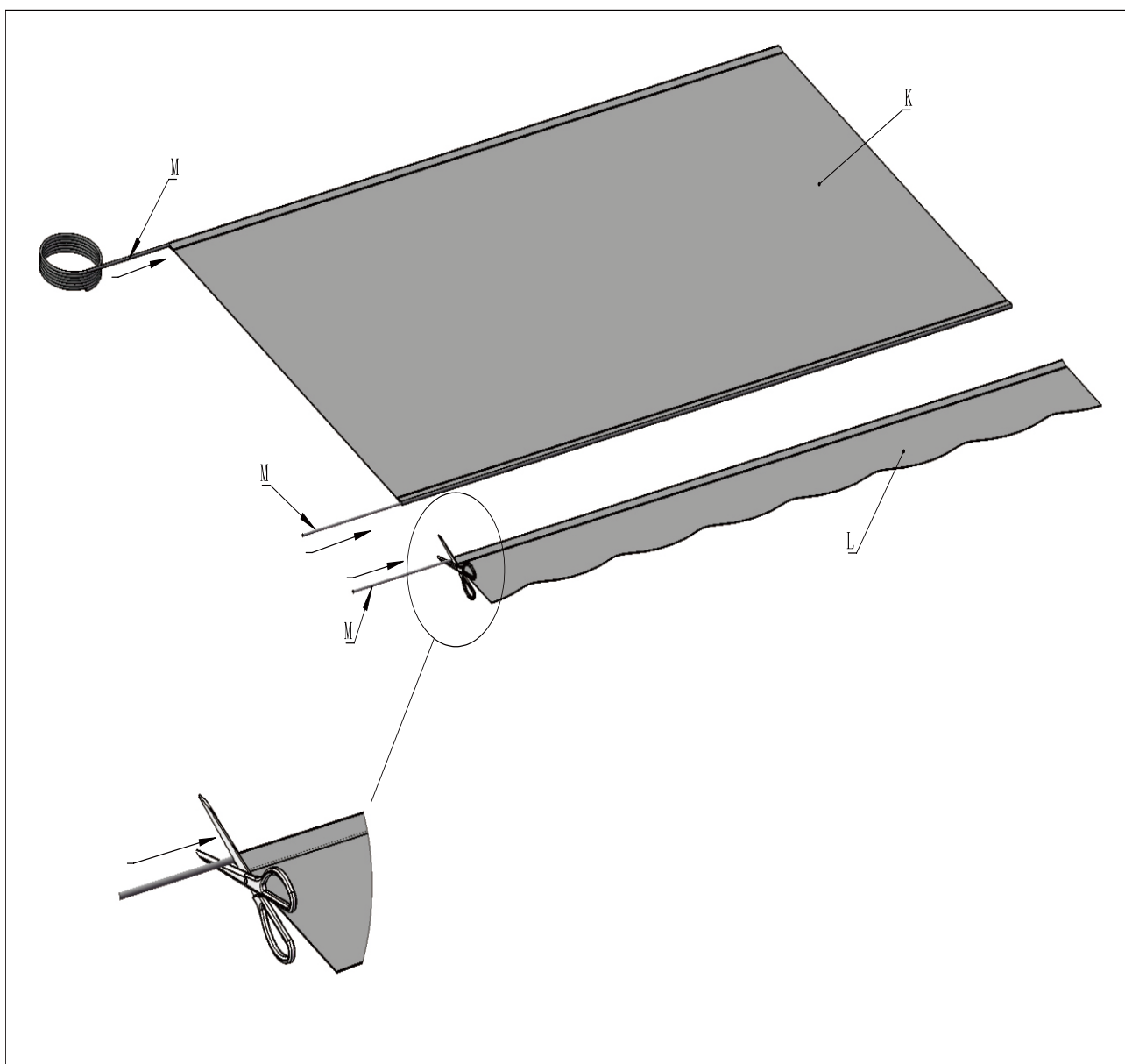

K 1Pc







L 1Pc



M 3Pc

PASO 2: Conecte el tubo del rodillo y la barra frontal (IZQUIERDA).

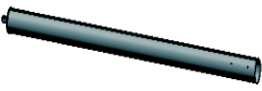

				
D 1Pc	H 1Pc	E 1Pc	G 1Pc	R 8Pcs

### PASO 3: Monte la tela y conecte el rollo y el dobladillo delantero

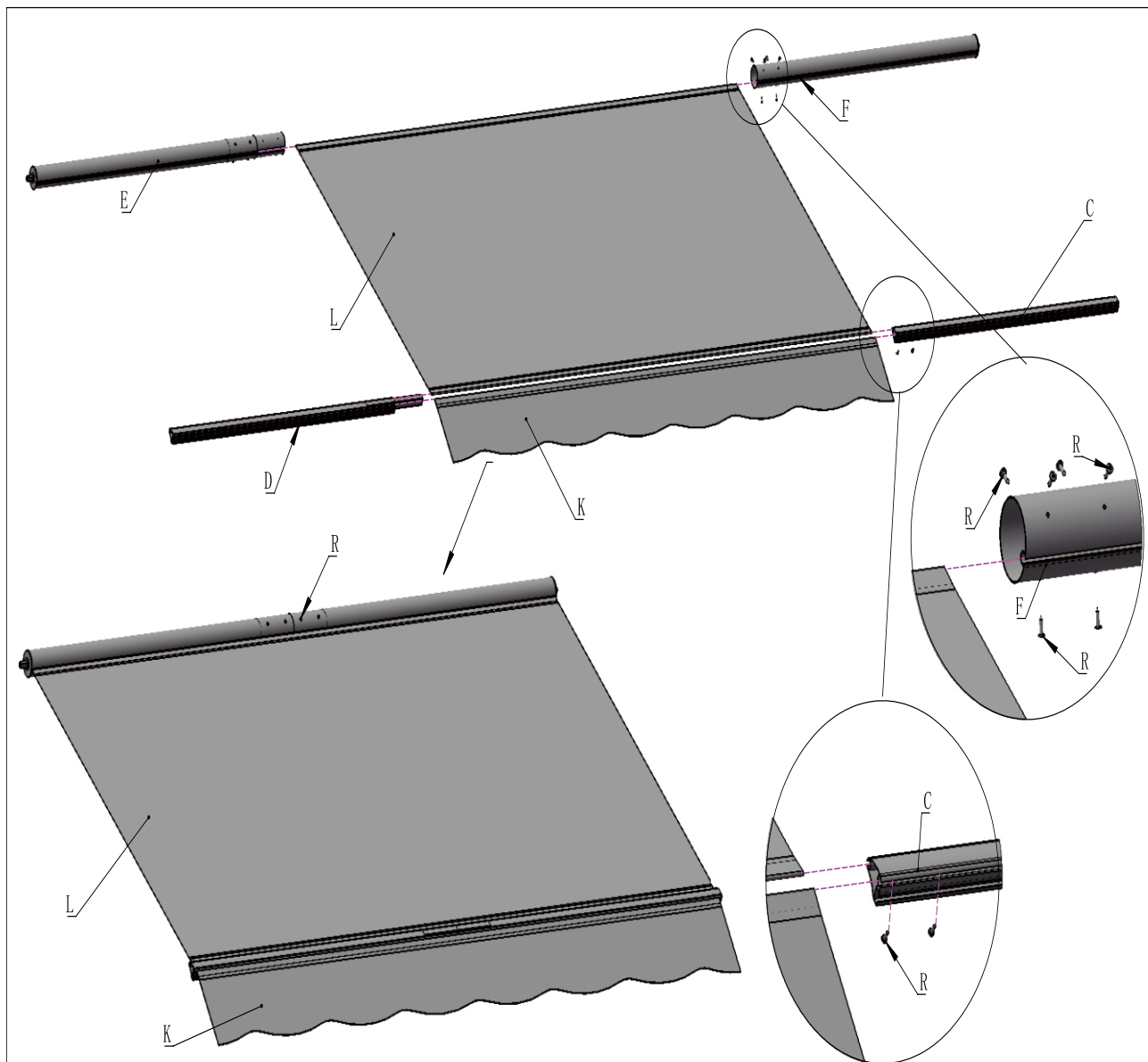

- |       |       |        |
|-------|-------|--------|
|       |       |        |
| C 1Pc | F 1Pc | R 8Pcs |

- PASO 4:**
- 1. Coloque el enlace de la barra del brazo en la barra frontal.**
  - 2. Coloque la pieza P en la barra frontal y fíjela con el tornillo Q.**
  - 3. Coloque las cubiertas de la barra delantera.**

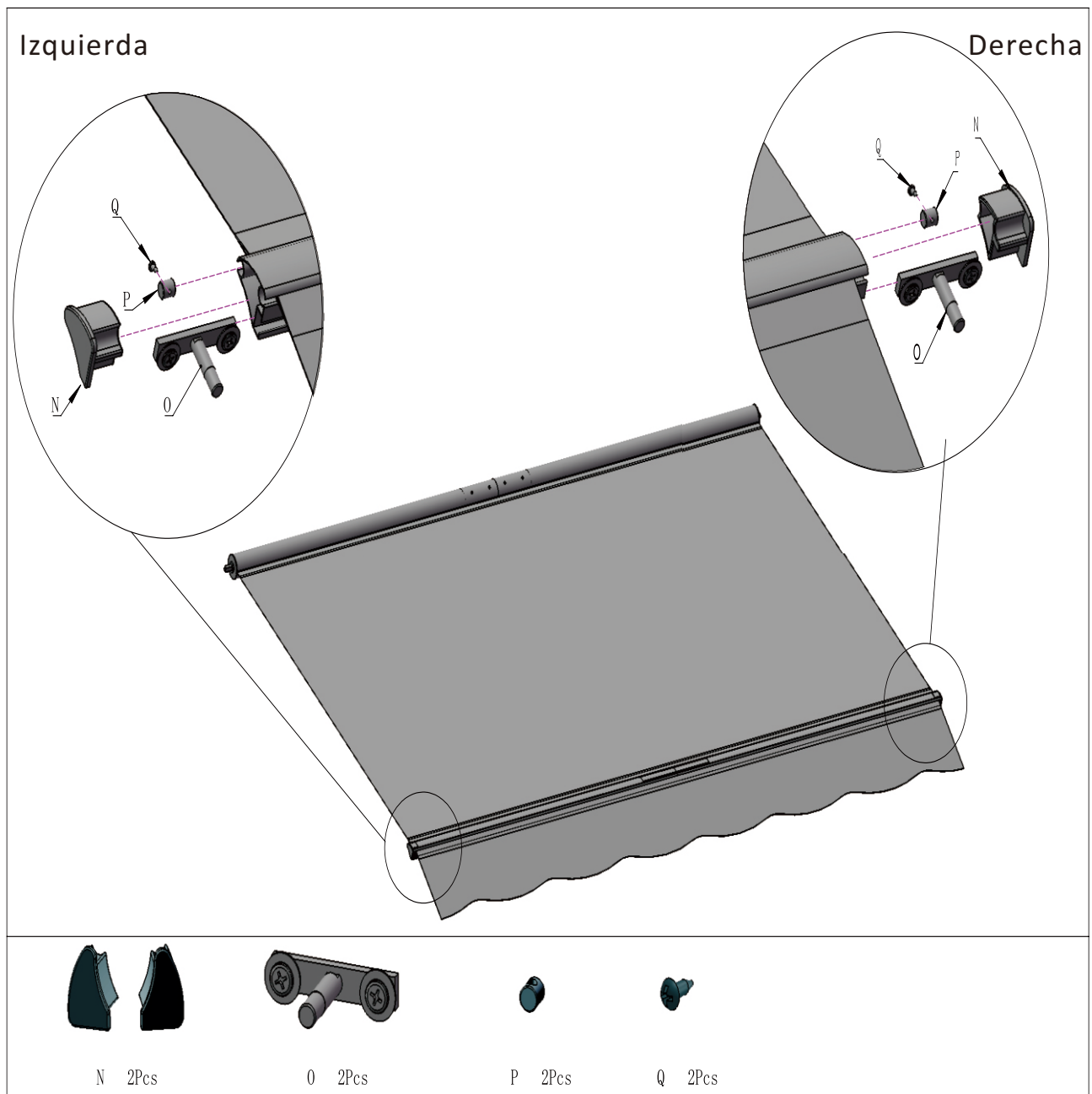

**PASO 5: Enrolle la tela del toldo lo más ajustadamente posible.**

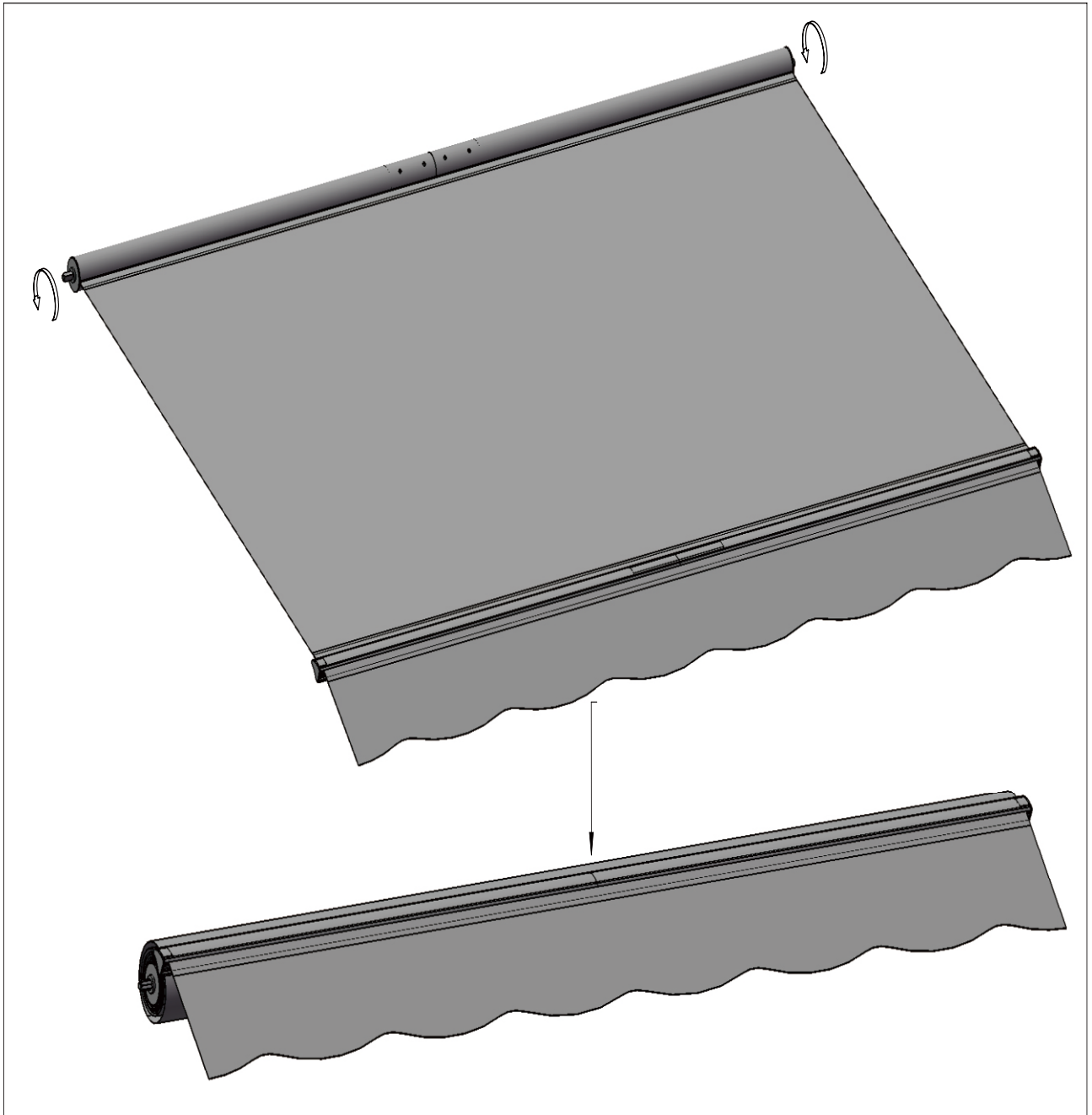

**PASO 6: Conecte la barra de torsión y atorníllela más tarde.**

**2. Coloque el rodillo en el agujero cuadrado de la caja de engranajes y en el cuadrado redondo del soporte del rodillo.**

**3. Conecte las dos barras de torsión y atorníllelas.**

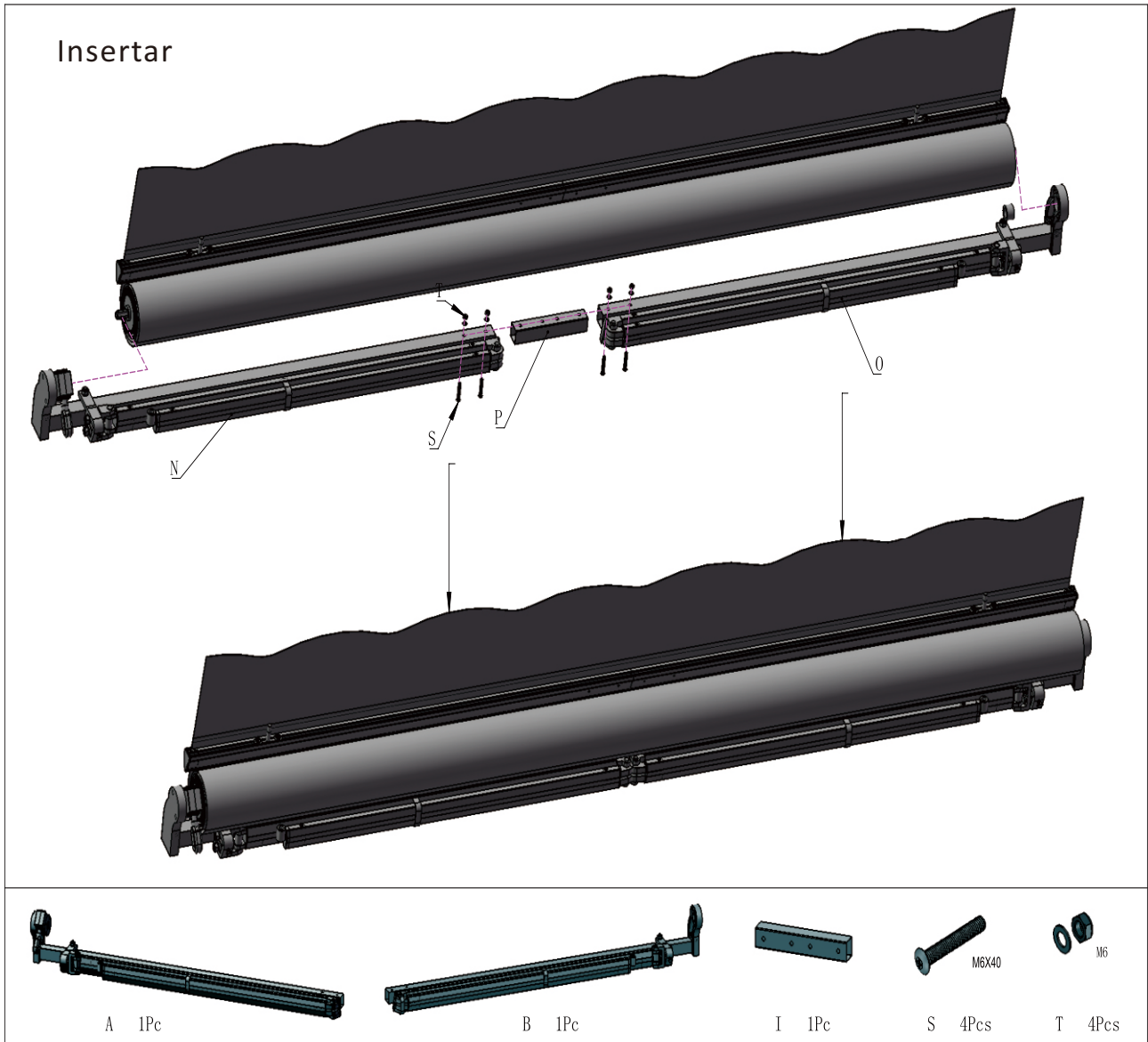

**PASO 7: Coloque el toldo en su posición.**

- 1. Mueva el brazo de soporte hasta que el soporte de la barra frontal quede conectado a través de él.**
- 2. Alinee la barra frontal y el brazo.**
- 3. Luego apriete el tornillo ajustable hasta el 90%.**

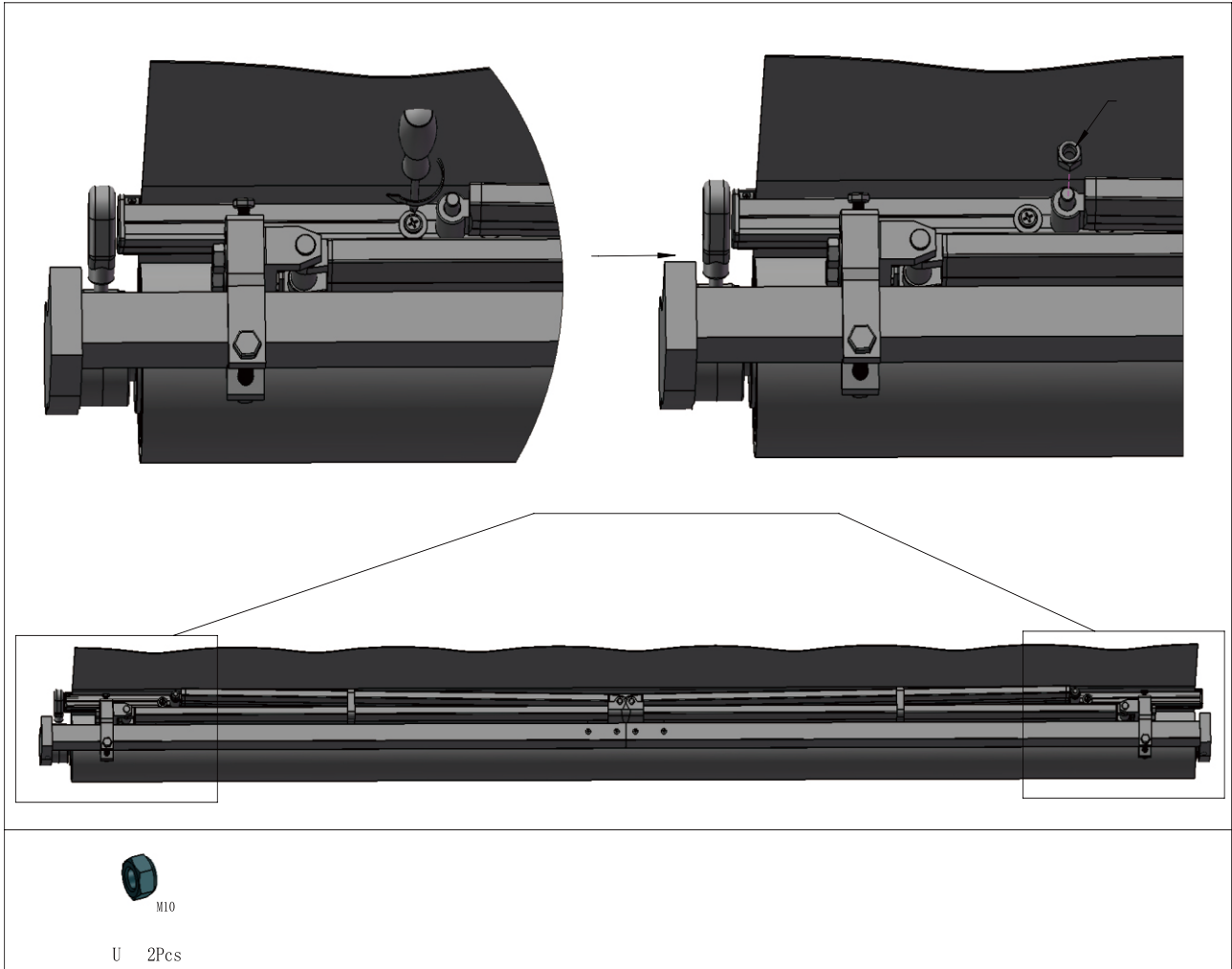

**PASO 8: Finalizando del montaje del toldo.**

1. Es seguro cortar las correas de seguridad que sujetan los soportes y la barra de torsión. El montaje del toldo está completo.
2. Ahora pase a la sección de montaje en la pared.

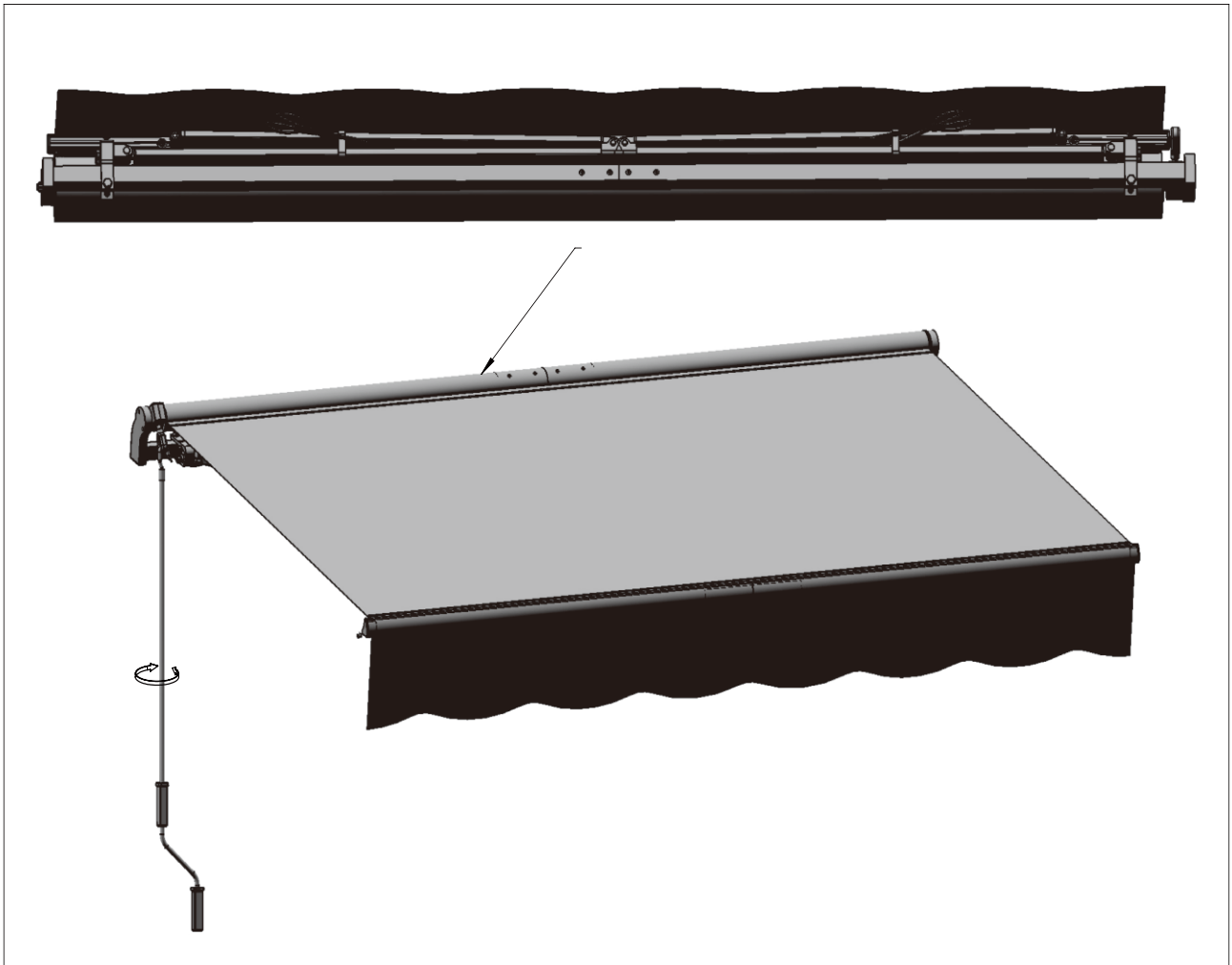

## 🔧 INSTALACIÓN

### Notas sobre el montaje en pared

Este toldo se puede fijar a paredes de hormigón armado, ladrillo y madera. Sin embargo, este kit de toldo sólo proporciona tornillos adecuados para el montaje en paredes de ladrillo y hormigón armado.

Si desea fijar su toldo a la madera, utilice tornillos de la longitud y diámetro adecuados para fijar el toldo a los soportes de madera. El tamaño de los tornillos depende del tamaño de la madera y se pueden adquirir en una ferretería. Recomendamos un instalador profesional para una instalación más segura y protegida.

¡Nunca intente fijar los soportes de pared en pavimentos sueltos o en superficies que no sean absolutamente firmes!



**CUIDADO:** La ubicación correcta de los soportes es el aspecto más importante en la instalación del toldo. Es esencial que todos los soportes de montaje estén asegurados a vigas, travesaños, soportes u otros componentes estructurales importantes.



**AVISO:** La falta de fijación segura de todos los soportes a la pared puede provocar el colapso de la toldilla y causar lesiones personales o la muerte.

### Altura de montaje

Es importante tener en cuenta la zona de inclinación del toldo antes de atornillar los soportes de pared. Si planea montarlo encima de una puerta de patio, por ejemplo, deje al menos 20 cm por encima del marco de la puerta y asegúrese de que el toldo no interfiera con la apertura y el cierre de la puerta. El ángulo de inclinación sólo se puede cambiar mínimamente, por lo que debes tenerlo en cuenta a la hora de decidir dónde colocar el toldo.

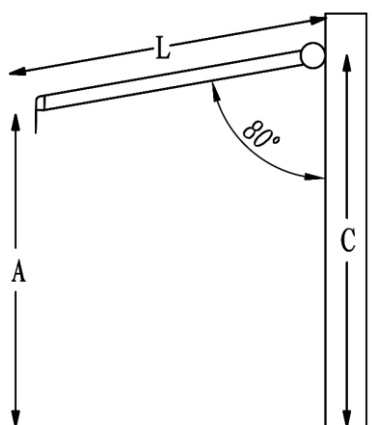

**Altura de instalación recomendada:** 2,4-3,6 metros.  
**El ángulo de caída ideal (cuando está completamente extendido) ya se ha configurado en fábrica.**, por lo que puede que no sea necesario cambiar el ángulo.  
**El toldo tiene caída.** 61 cm en pendiente, o 15 grados

### CÁLCULOS:

Puede utilizar la siguiente fórmula para calcular el ángulo apropiado

$$C = A + 0,17 * L$$

A= La altura deseada de la barra frontal.

L= La pierna del brazo estirado.

C= La altura de los soportes de pared.

Recomendamos que la superficie del toldo esté en un ángulo de unos 80 grados con respecto a la pared cuando esté abierto.

**PASO 1: Medir la ubicación de montaje**

1. Mide la altura de tu toldo a lo largo de la pared donde quieras instalarlo. Esta línea será el punto más alto del toldo y estará alineada con la parte superior del soporte de pared. Utilice un nivel para hacer una línea de tiza a lo largo de la distancia.
2. Importante: verifique que la línea esté nivelada en toda su longitud.
3. Asegúrese de que la línea esté centrada sobre la puerta del patio, la ventana u otra característica, si corresponde.
4. Ahora que tienes una línea recta centrada, mide el punto medio y márcalo. Aquí es donde se colocará el soporte de pared central. Aquí es donde se instalará el soporte de pared central.
5. Tome un soporte de pared y coloque su parte superior, completamente nivelada, debajo de la línea, como se muestra en el diagrama a continuación. Con tiza o un lápiz, marque la posición de todos los soportes de pared y sus orificios para tornillos.

Toldo < 3,30 m	Sólo requiere 2 soportes de pared en total: uno para cada extremo de las barras de torsión.
Toldo < 3,30-4,25 m	Requiere un total de 3 soportes de pared: uno para cada extremo y otro en el medio.
Toldo < 4,40-6 m	Requiere 4 soportes de pared en total: uno para cada extremo y dos en el medio.

Soporte de pared al ras de la línea horizontal | Soporte de pared al ras de la línea horizontal

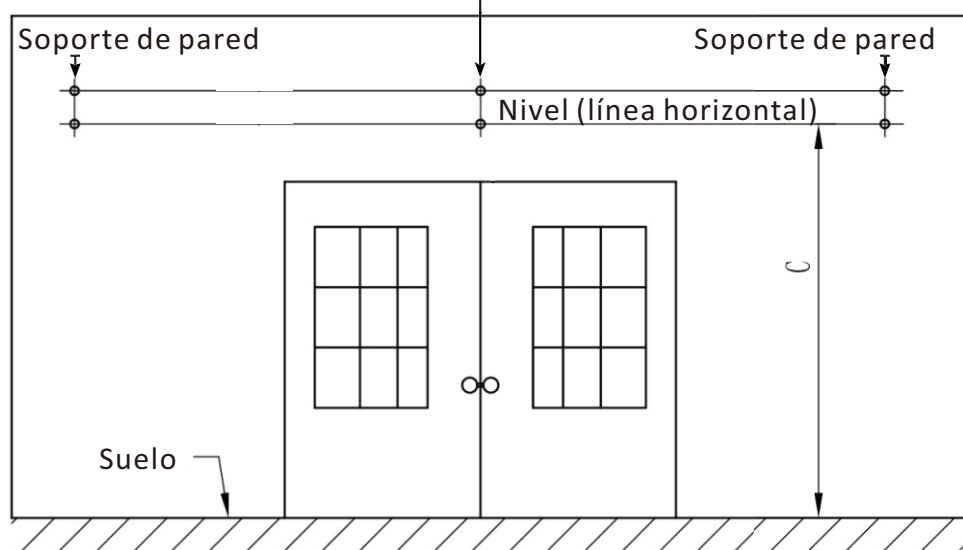

**PASO 2: taladre los orificios para los tornillos**

1. Ahora que tiene una línea recta y nivelada a lo largo de la pared con las ubicaciones de los soportes de pared y sus soportes marcados, taladre los orificios para montar los soportes.
2. Con una broca de 14 mm, taladre el primer orificio de unos 9 centímetros de profundidad, como se muestra en el diagrama. Esto se debe hacer utilizando ladrillo macizo o cemento para obtener el soporte necesario para el toldo.
3. Taladre los agujeros restantes exactamente como en el paso 2.

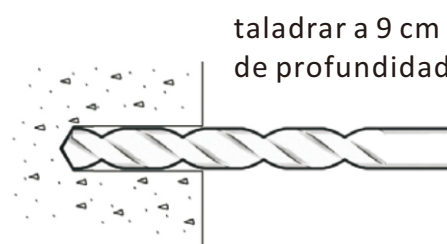

**!! IMPORTANTE:** Todos los orificios para tornillos deben estar alineados vertical y horizontalmente para garantizar que el toldo quede recto. Vuelva a verificar la alineación antes de perforar si no está seguro.

**!! IMPORTANTE:** El diámetro y la profundidad de los agujeros deben ser del mismo tamaño que los tacos.

### Paso 3: Preparación para el montaje

1. Ahora que los agujeros están perforados, inserte los tacos.
2. Puede que sea necesario introducirlos con un martillo de madera (o no metálico).



Si se requiere un martillo para la instalación, recomendamos colocar la tuerca en el perno (sin apretar) antes de martillar para evitar dañar las roscas del perno.

3. Asegúrese de que los tacos estén firmemente en su lugar, pero permita que sobresalgan de la pared aproximadamente una pulgada, lo suficiente para que se pueda instalar el soporte de pared en ellos.

4. Apriete los tornillos firmemente con una llave hexagonal de 19 mm. Es preferible utilizar la llave hexagonal con el extremo cerrado en lugar de abierto para evitar dañar la tuerca si se desliza.

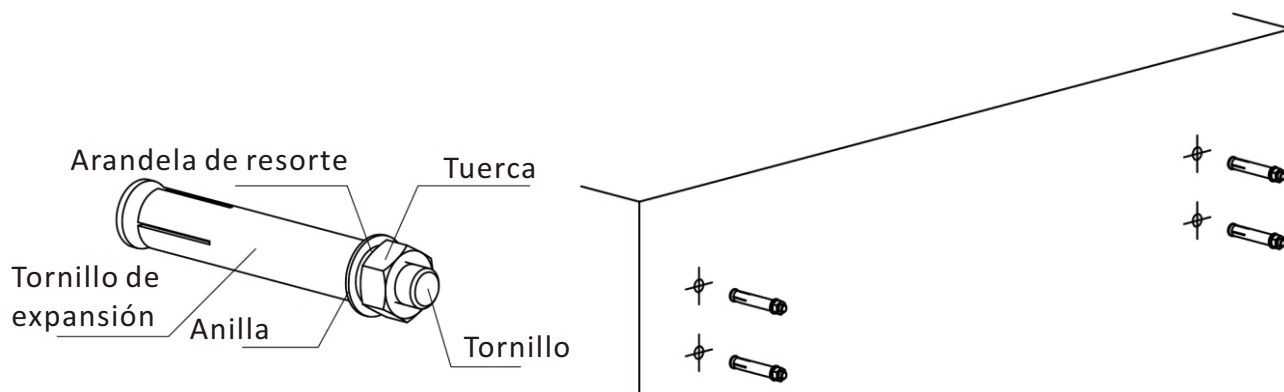

### PASO 4: Montaje de los soportes de pared

1. Ahora que los tornillos están fijados a la pared, retire las tuercas que están colocadas sin apretar en los tornillos.
2. Coloque un soporte de pared sobre un juego de tornillos. Esto debería encajar si los orificios de los tornillos están alineados correctamente.
3. Cuando el soporte de pared esté asentado sobre los tornillos, coloque una arandela sobre el tornillo y luego asegúrelo con una tuerca como se muestra en el diagrama.
4. Los soportes DEBEN estar fijados firmemente a la pared. Si hay algún movimiento, es necesario apretarlo más.
5. Repita este paso para cada uno de los soportes de pared. Una vez que haga esto, todos los soportes de pared estarán firmemente en su lugar.

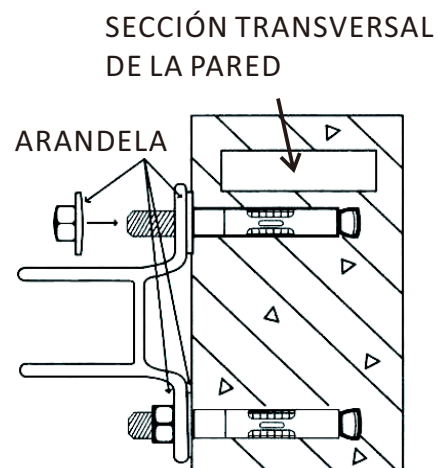

**PASO 5: Montaje del toldo**

1. Ahora que los soportes de pared están seguros y en su lugar, es momento de instalar el toldo en los soportes.
2. Se requieren al menos dos escaleras o sillas para instalar el toldo.
3. Coloque los tornillos de expansión originales en los soportes de pared y apriételos.
4. Finalmente, apriete todos los tornillos de expansión.
5. Usando la manivela o un motor (si corresponde), abra el toldo completamente. La barra frontal debe estar nivelada.
6. ¡Felicidades! Tu toldo está instalado. Si estás satisfecho con la altura o la barra frontal (inclinación del toldo), ¡siéntate y disfruta! Si no, sigue leyendo.

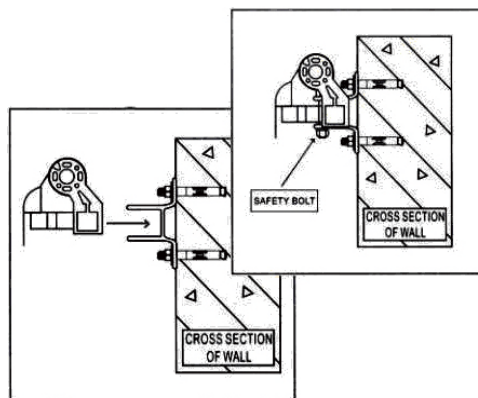

**😊 INSTALACIÓN OPCIONAL**

**AJUSTAR LA INCLINACIÓN/ÁNGULO DEL TOLDO**

Cada toldo viene con un ángulo (ángulo) predefinido que se considera ideal. Sin embargo, si es necesario un ajuste, se puede realizar en unos sencillos pasos.

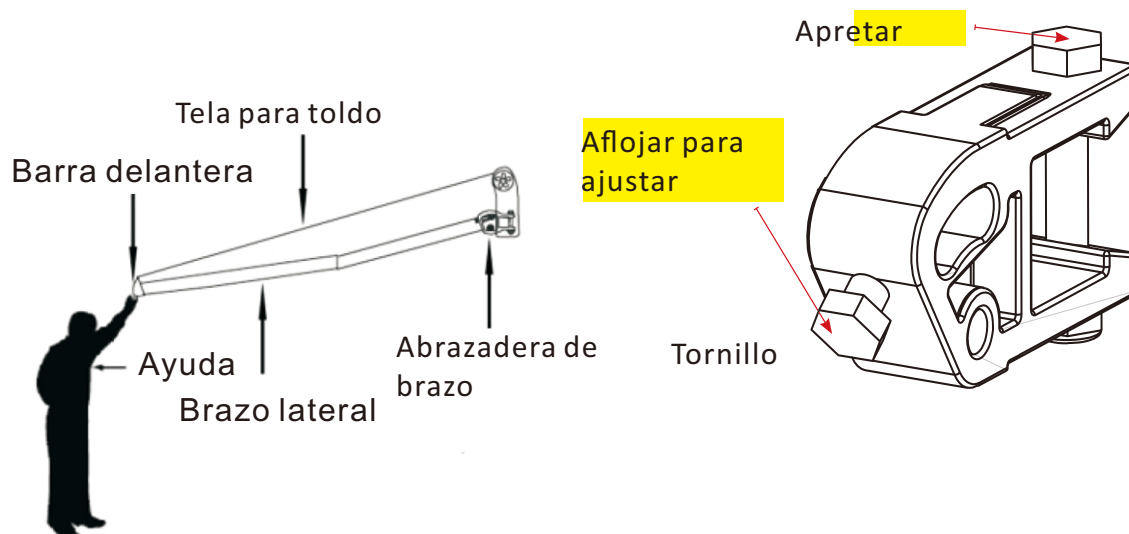

**!! IMPORTANTE:** Al levantar la barra frontal se reducirá el ángulo del tejido, aumentando así el riesgo de que el agua de lluvia se acumule sobre el tejido. Para evitar que el toldo se colapse debido al peso del agua de lluvia, deberá retraer el toldo cuando no esté en uso. De lo contrario, el toldo podría romperse o provocar lesiones personales.

**Nota:** Asegúrese de que la barra frontal esté ajustada para que esté completamente nivelada. Cualquier desalineación resultará en una retracción incorrecta.

Errores comunes

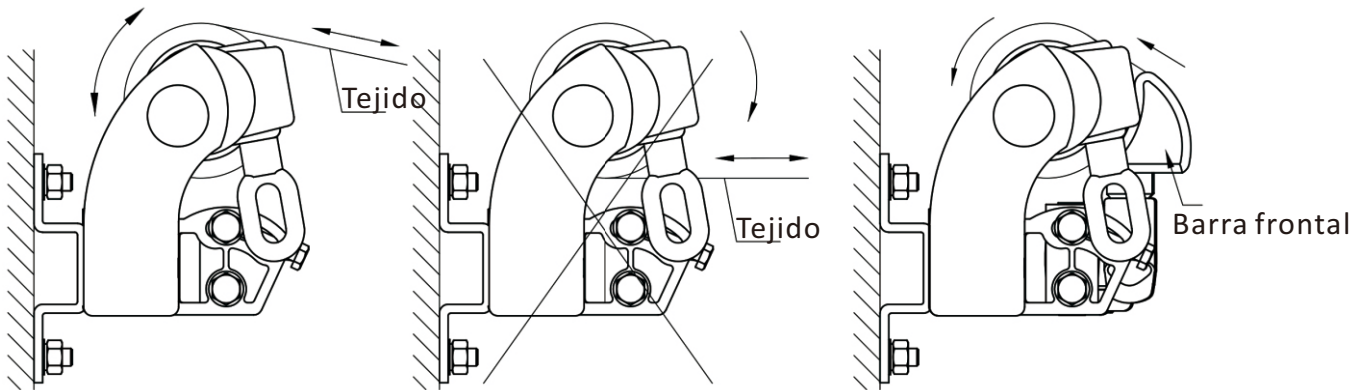

Funcionamiento correcto







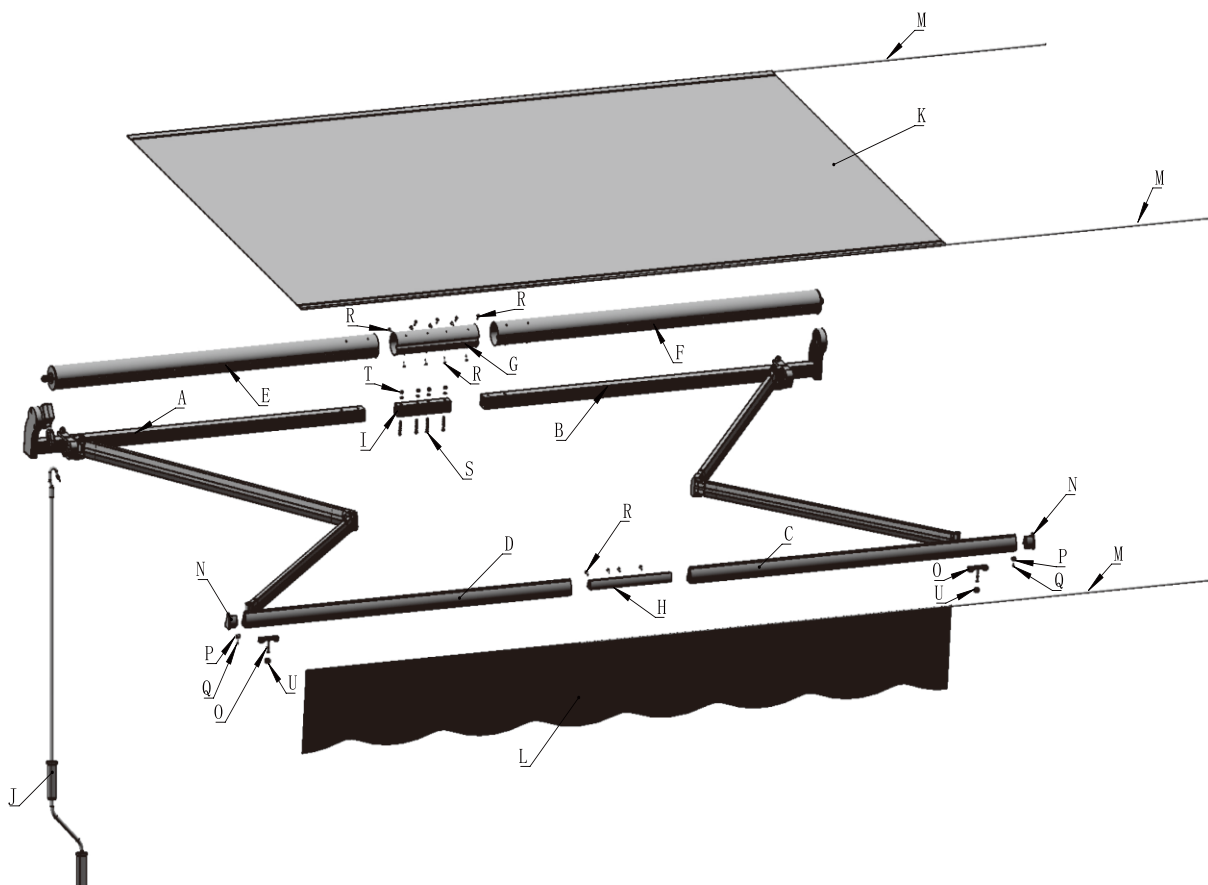



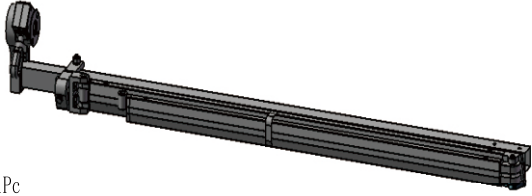
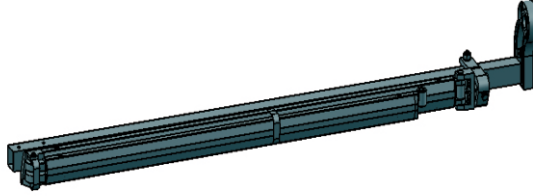

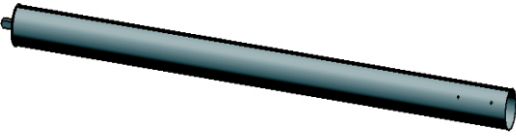
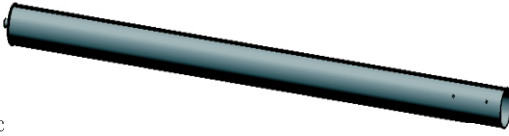
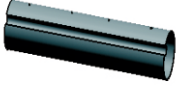

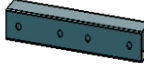

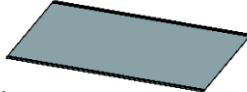



Funcionamiento incorrecto

ADVERTENCIA: Cuando la barra frontal toque el rodillo, como se muestra en la figura, no intente acercarlas, de lo contrario el producto podría dañarse.

- A. Barra de torção com braço (esquerda)
- B. Barra de torção com braço (direita)
- C. Barra de torção (direita)
- D. Barra de torção (esquerda)
- E. Rolo (esquerda)
- F. Rolo (direita)
- G. Conector do rolo
- H. Conector da barra frontal
- I. Conector da barra de torção
- J. Manivela de mão
- K. Tecido
- L. Saia
- M. Forro de tecido
- N. Tampas da barra dianteira (esquerda e direita)
- O. Braçadeira de braço
- P. Parafuso de plástico para a cobertura e o revestimento de tecido
- Q. Parafuso St3x10
- R. Parafuso St14x15
- S. M640
- T. M6
- U. M10
- V. M8x55
- W. M8
- X. Parafuso de expansão
- Y. Suportes de parede

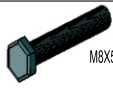

LISTA DE PEÇAS

 <p>A 1Pc</p>		 <p>B 1Pc</p>							
 <p>C 1Pc</p>		 <p>D 1Pc</p>							
 <p>E 1Pc</p>		 <p>F 1Pc</p>							
 <p>G 1Pc</p>	 <p>H 1Pc</p>	 <p>I 1Pc</p>	 <p>J 1Pc</p>						
 <p>K 1Pc</p>	 <p>L 1Pc</p>	 <p>M 3Pc</p>							
 <p>N 2Pcs</p>	 <p>O 2Pcs</p>	 <p>P 2Pcs</p>	 <p>Q 2Pcs</p>	 <p>R 16Pcs</p>	 <p>S 4Pcs</p>	 <p>T 4Pcs</p>	 <p>U 2Pcs</p>	 <p>V 2Pcs</p>	 <p>W 2Pcs</p>
 <p>X 4Pcs</p>	 <p>Y 2Pcs</p>	 <p>Z 4Pcs</p>							

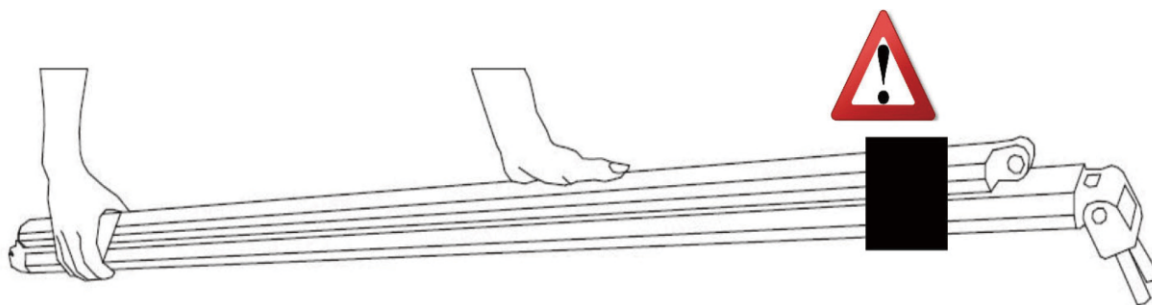

**ATENÇÃO!**  
OS BRAÇOS DO TOLDO PODEM PROVOCAR  
FERIMENTOS!

**CORTAR AS FITAS DOS BRAÇOS DO TOLDO APENAS DEPOIS DE O  
TOLDO ESTAR COMPLETAMENTE MONTADO**

**X** Errado



**✓** Correto



**AVISO**  
PODE CAUSAR FERIMENTOS!  
CORTAR APENAS DEPOIS DE COMPLETAMENTE MONTADO

**PASSO 1: Enfiar o fio no tecido e cortar no mesmo comprimento que o tecido.**

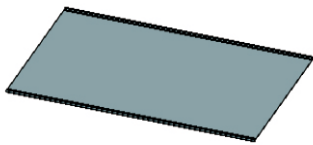
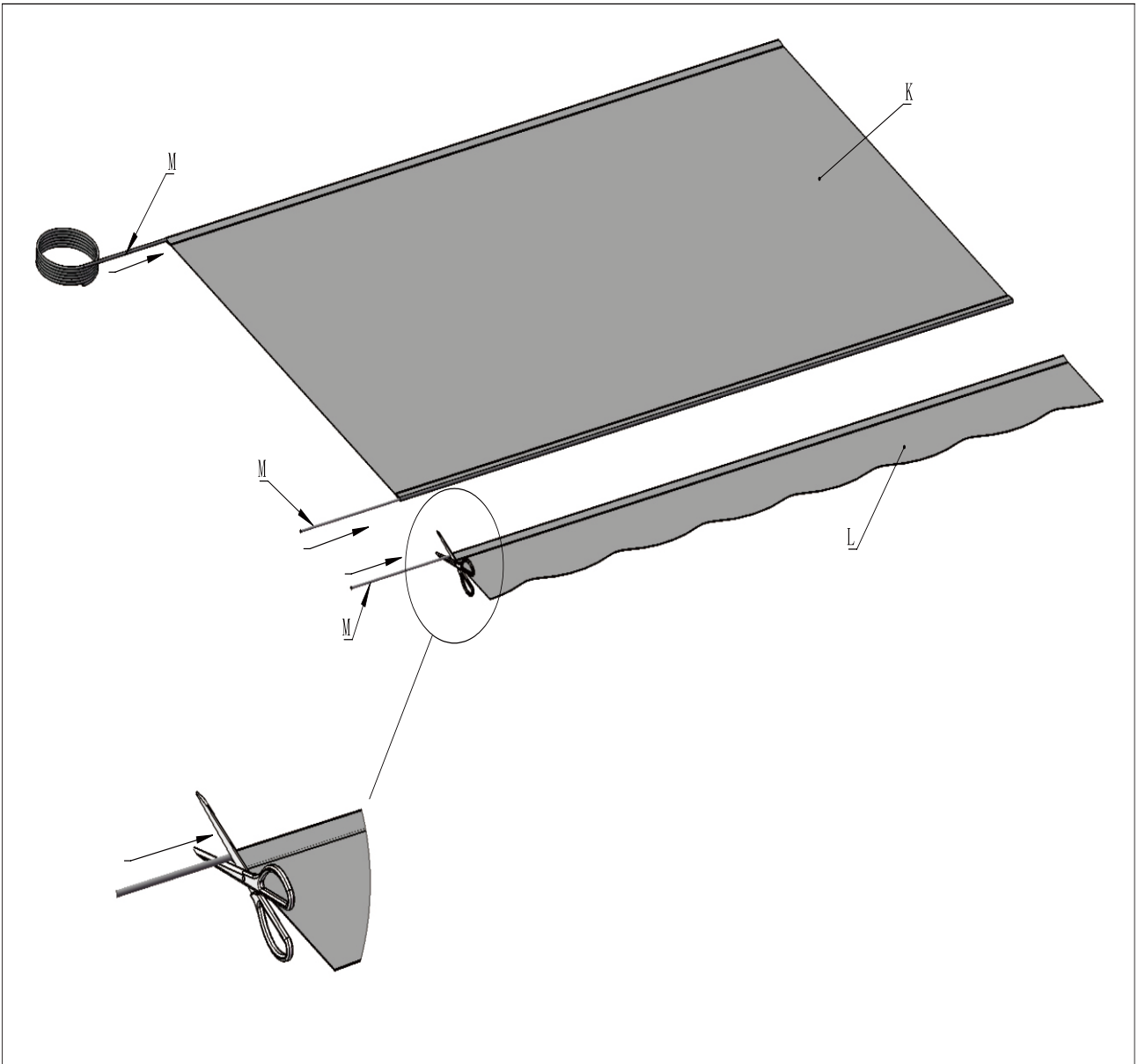

K 1Pc







L 1Pc

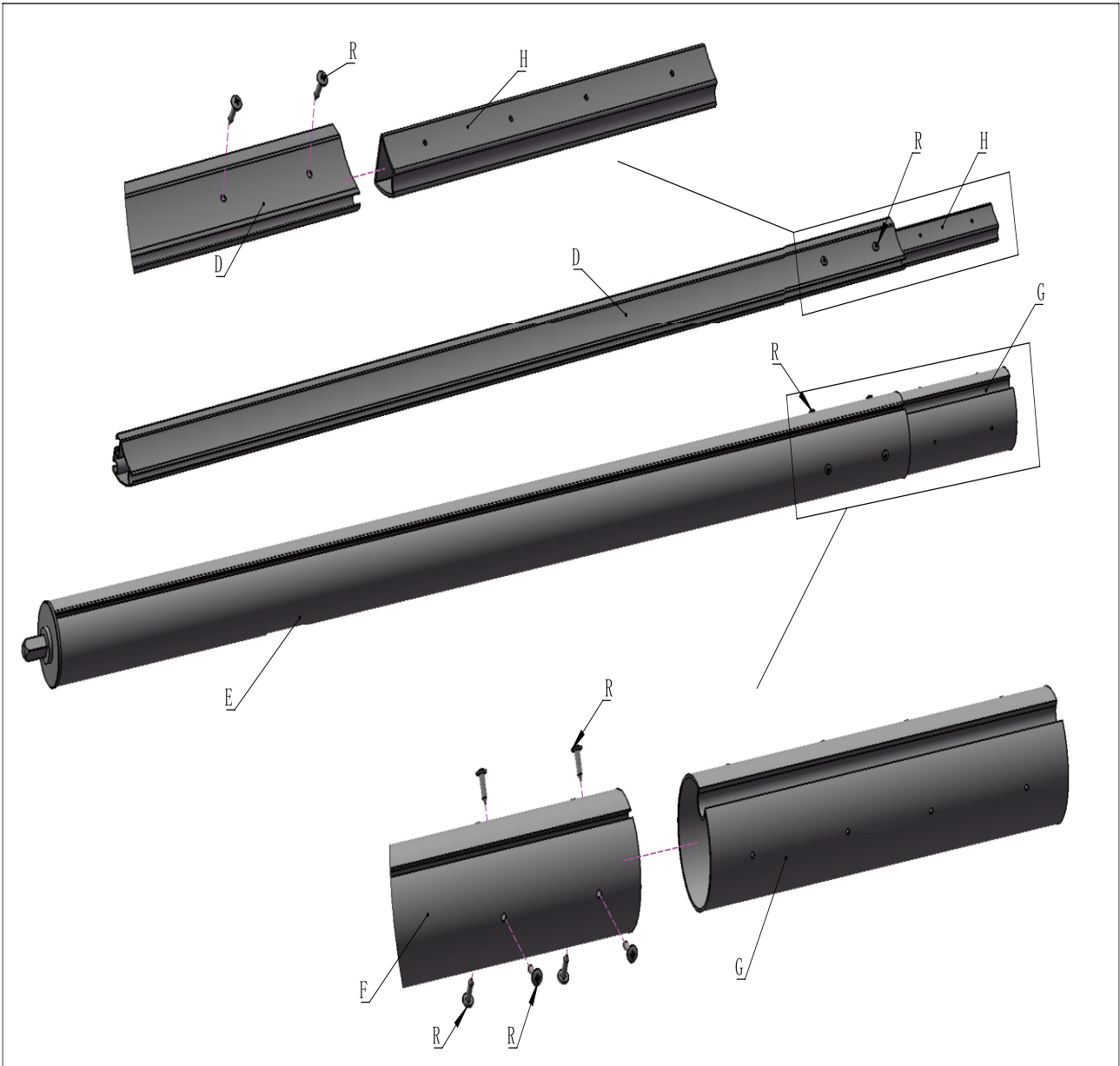

M 3Pc

**PASSO 2: Conectar o tubo do rolo e a barra dianteira (ESQUERDA).**

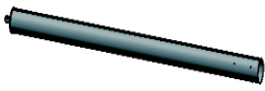

				
D 1Pc	H 1Pc	E 1Pc	G 1Pc	R 8Pcs

### PASSO 3: Montagem do tecido e conexão do rolo e da barra frontal

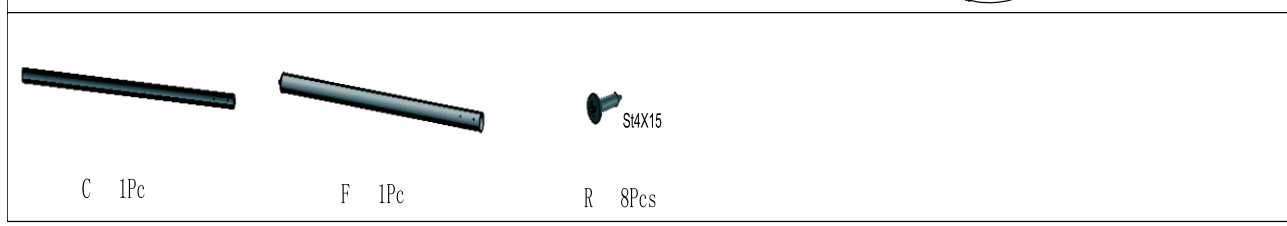
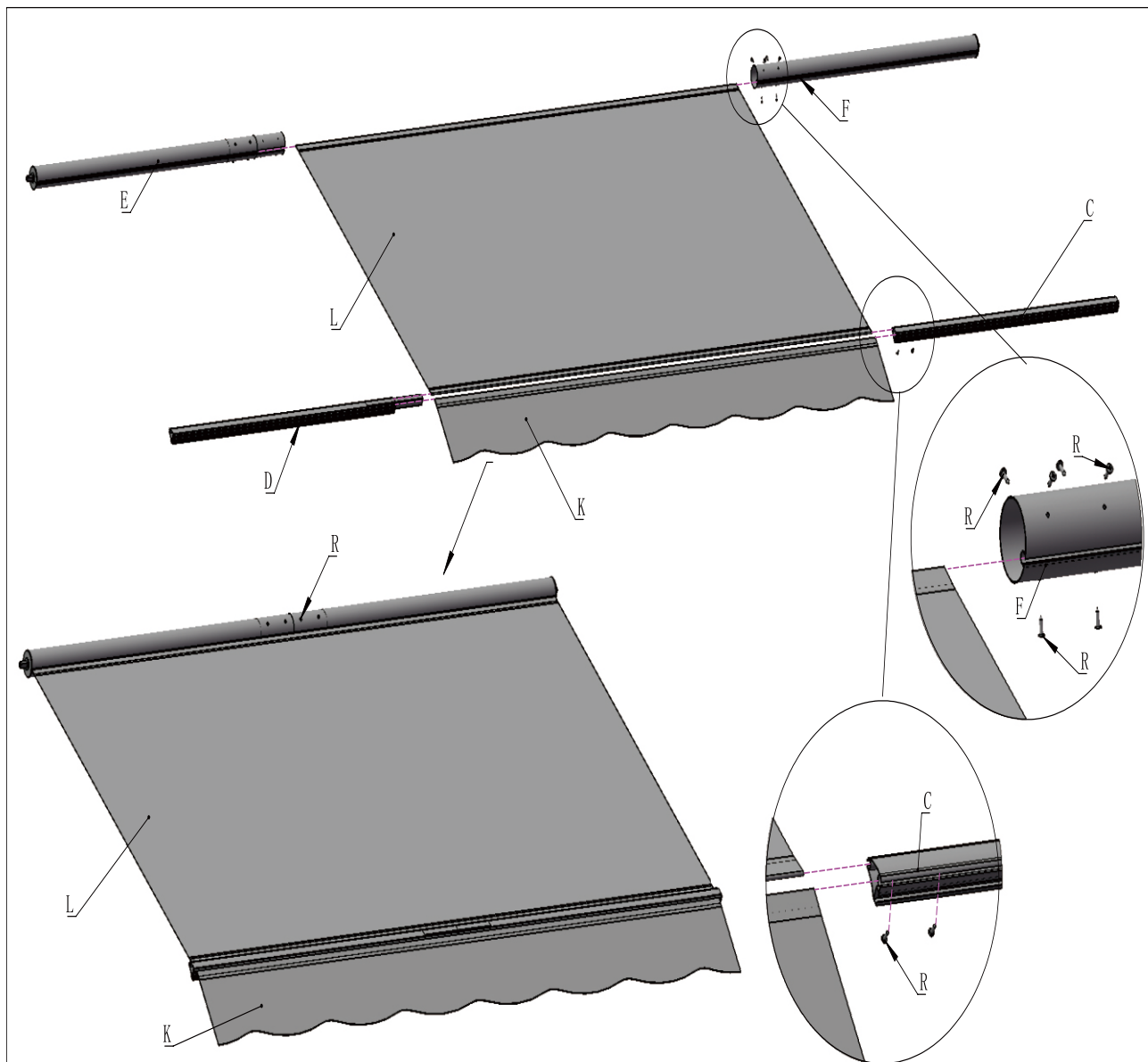

- PASSO 4:** 1. Coloque o elo da barra de braço na barra dianteira.  
2. Coloque a peça P na barra dianteira e fixe-a com o parafuso Q.  
3. Coloque as tampas da barra dianteira

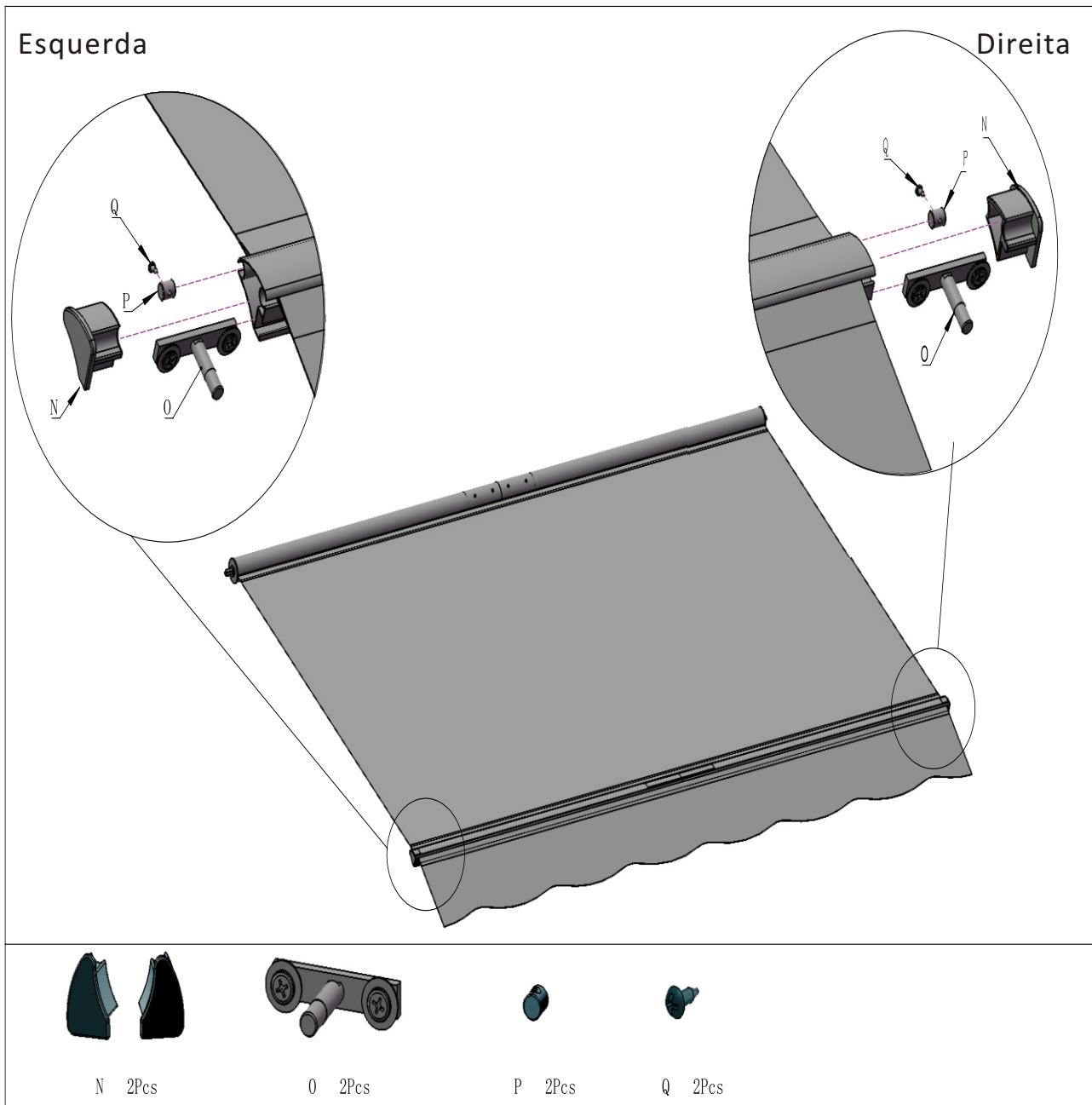

**PASSO 5: Enrolar o tecido do toldo o mais apertado possível.**

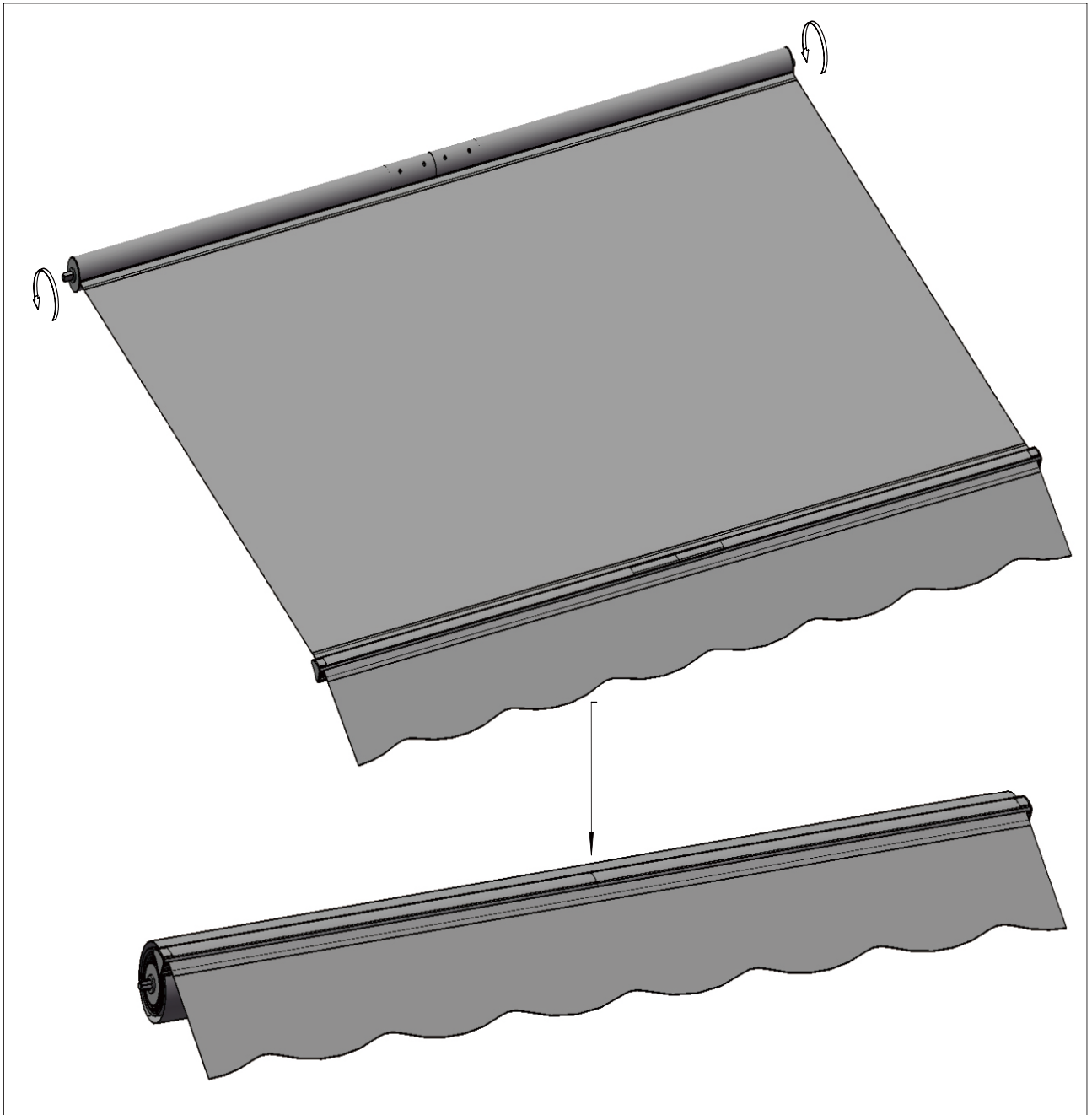

- PASSO 6: Conectar a barra de torção e aparafusá-la posteriormente.**
- 2. Colocar o rolo no orifício quadrado da caixa de engrenagens e no quadrado redondo do suporte do rolo.**
  - 3. Conectar as duas barras de torção e aparafusá-las.**

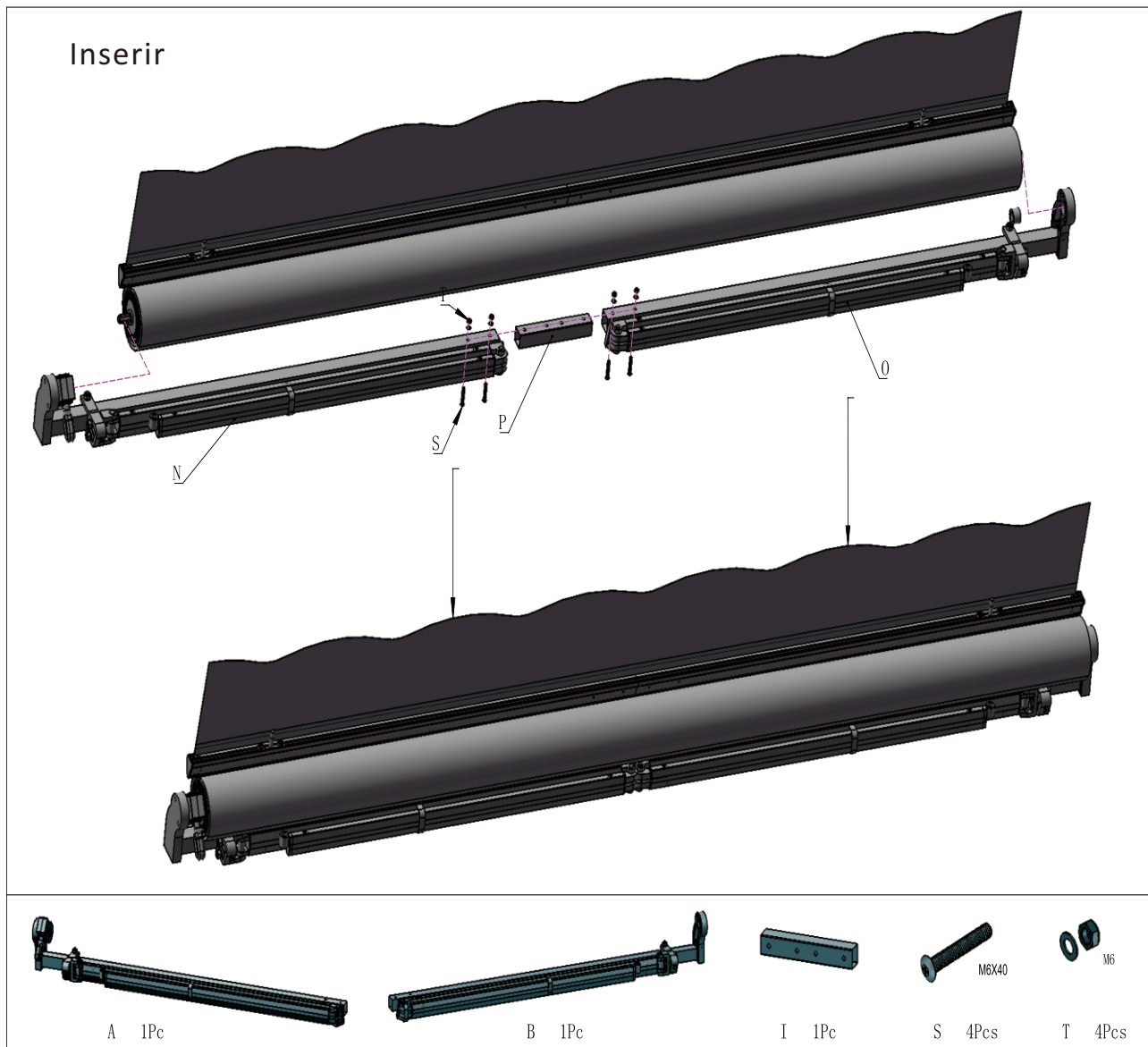

**PASSO 7: Colocar o toldo em posição.**

1. Mover o braço de suporte até que o apoio da barra frontal esteja conectado através dele.
2. Alinhar a barra da frente e o braço.
3. De seguida, aperte o parafuso ajustável até 90%.

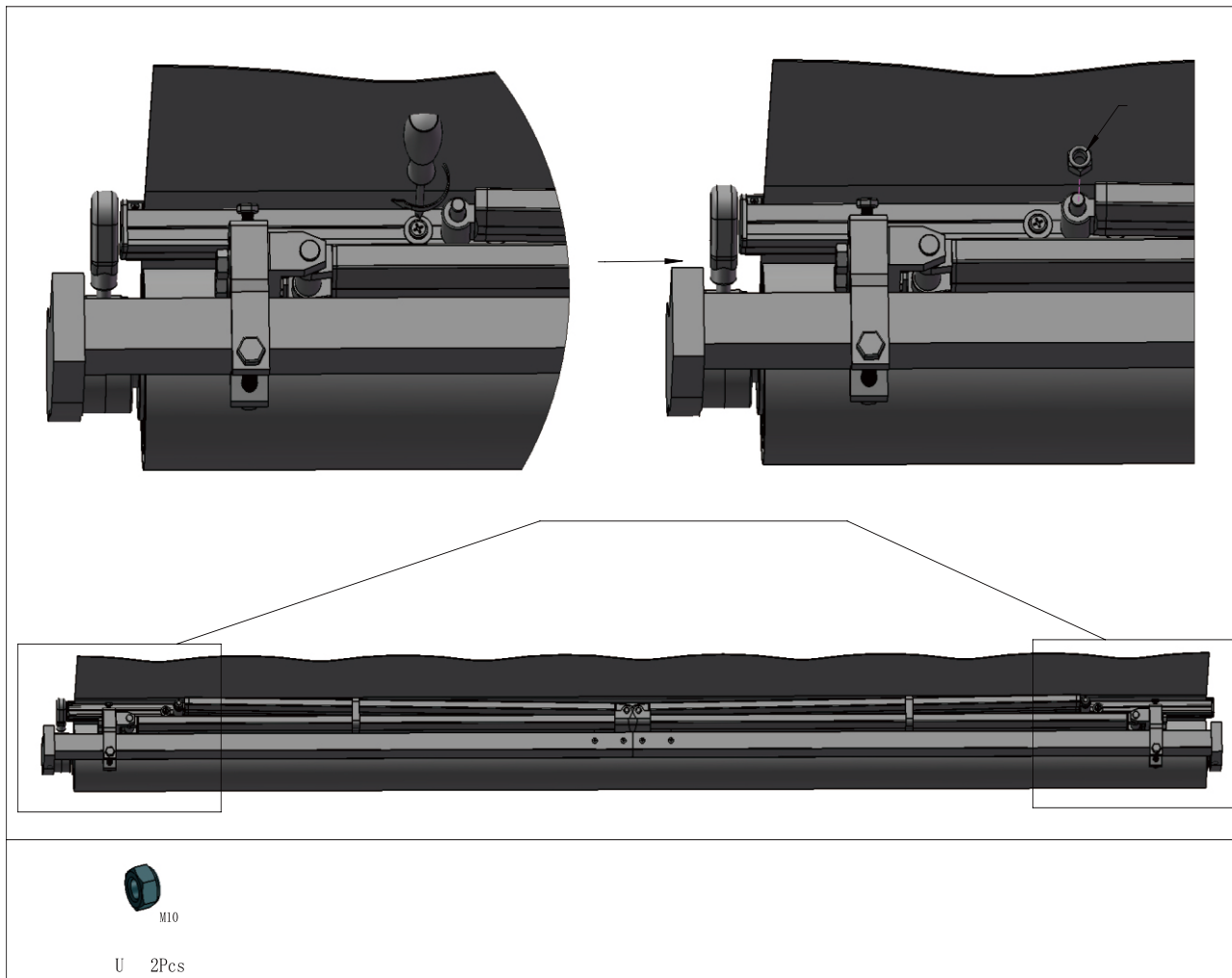

**PASSO 8: Acabamento da montagem do toldo.**

1. É seguro cortar as correias de segurança que prendem os suportes e a barra de torção. A montagem do toldo está concluída.
2. Agora, passe para a secção de montagem na parede.

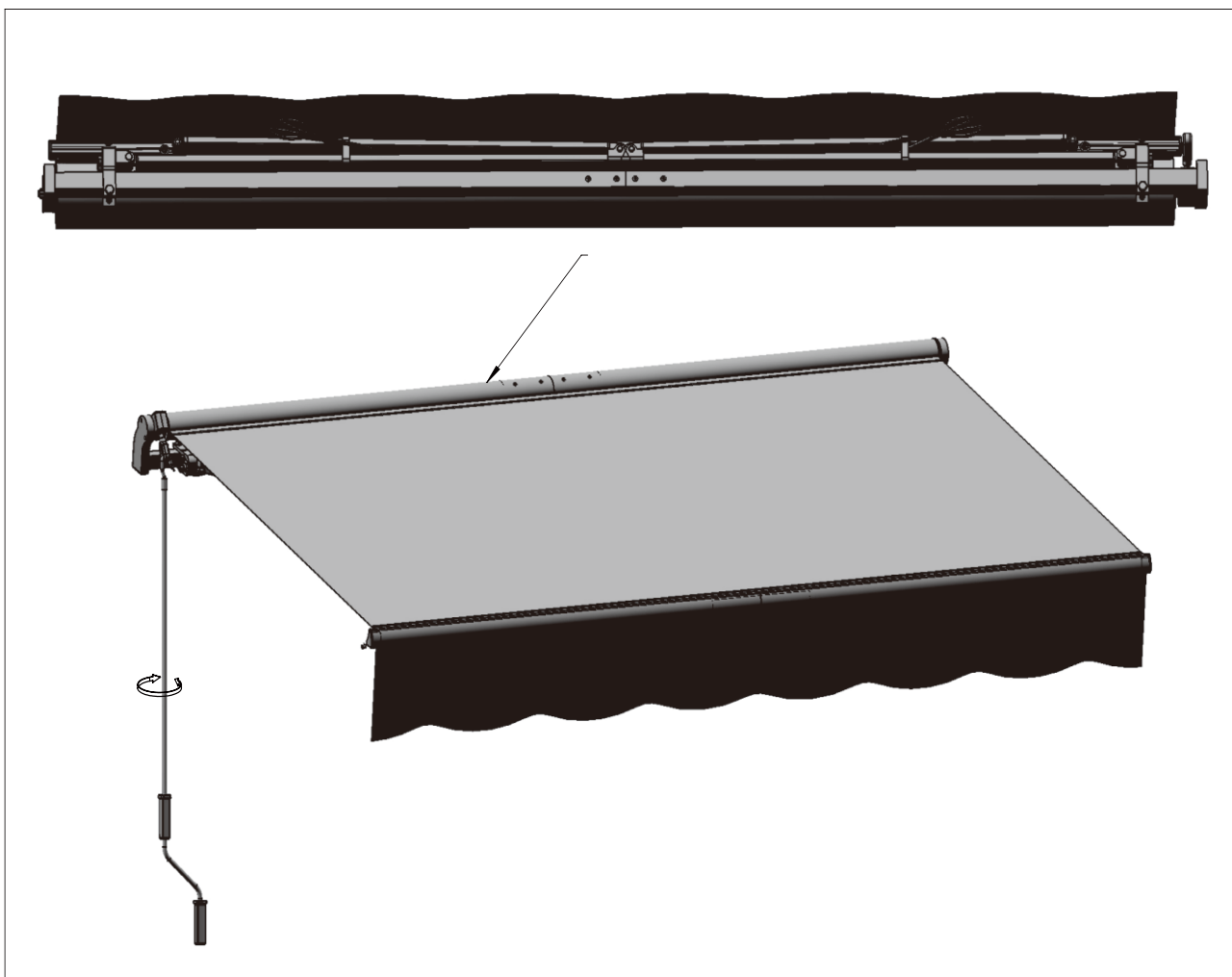

## 🔧 INSTALAÇÃO

Notas sobre a montagem na parede

Este toldo pode ser fixado em paredes de cimento reforçado, tijolo e madeira. No entanto, este kit de toldo apenas fornece parafusos adequados para montagem em paredes de tijolo e cimento reforçado.

Se pretender fixar o seu toldo à madeira, utilize parafusos de comprimento adequado e com um diâmetro apropriado para fixar o toldo aos suportes de madeira. O tamanho dos parafusos depende do tamanho da madeira e podem ser adquiridos numa loja de ferragens. Recomendamos um instalador profissional para uma instalação mais segura e protegida.

Nunca tente fixar os suportes de parede a pavimentos soltos ou a superfícies que não sejam absolutamente firmes!



**CUIDADO:** A localização correta dos suportes é o aspeto mais importante da instalação do toldo. É fundamental que todos os suportes de montagem sejam fixados a vigas, travessas, suportes ou outros componentes estruturais importantes



**AVISO:** A não fixação segura de todos os suportes à parede pode provocar o desmoronamento do toldo e causar ferimentos pessoais ou morte

### Altura de montagem

É importante ter em consideração a área de inclinação do toldo antes de aparafusar os suportes de parede. Se pretender montar por cima de uma porta de pátio, por exemplo, deixe pelo menos 20 cm acima da moldura da porta e certifique-se de que o toldo não interfere com a abertura e o fecho da porta. O ângulo de inclinação só pode ser alterado minimamente, pelo que deve ter isto em consideração quando decidir onde colocar o toldo.

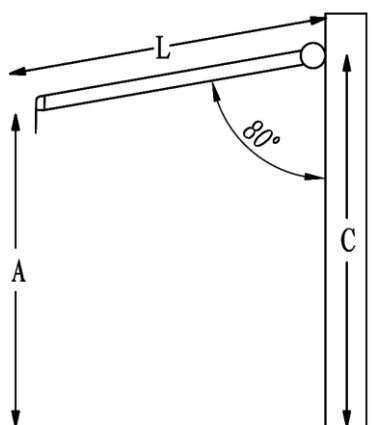

**Altura de instalação recomendada:** 2,4-3,6 m.

**O ângulo de queda ideal (quando totalmente estendido) já foi definido na fábrica,** pelo que poderá não ser necessário alterar o ângulo.

**O toldo tem uma queda** de 61 cm quando em declive, ou 15 graus

#### CÁLCULOS:

Pode utilizar a seguinte fórmula para calcular o ângulo adequado

$$C = A + 0,17 * L$$

A = A altura pretendida da barra frontal

L = A perna do braço esticado.

C = A altura dos suportes de parede

Recomendamos que a superfície do toldo faça um ângulo de cerca de 80 graus em relação à parede quando aberta.

## PASSO 1: Medição do local de montagem

1. Meça a altura do seu toldo ao longo da parede onde o pretende instalar. Esta linha será o ponto mais alto do toldo e estará alinhada com a parte superior do suporte de parede. Utilize um nivelador para fazer uma linha de giz ao longo da distância.
2. Importante: verifique duplamente se a linha está nivelada em toda a sua extensão.
3. Certifique-se de que a linha está centrada sobre a porta do pátio, janela ou outra característica, se aplicável.
4. Agora que tem uma linha reta e centrada, meça o ponto médio e marque-o. É aqui que o suporte de parede do meio será colocado. É aqui que o suporte de parede do meio será instalado.
5. Pegue num suporte de parede e coloque a parte superior do mesmo, completamente nivelada, sob a linha, como mostra o diagrama abaixo. Com giz ou um lápis, marque a posição de todos os suportes de parede e os respectivos orifícios para os parafusos.

Toldo < 3,30 m	Requer apenas 2 suportes de parede no total: um para cada extremidade das barras de torção.
Toldo < 3,30-4,25 m	Requer um total de 3 suportes de parede: um para cada extremidade e um no meio.
Toldo < 4,40-6 m	Requer 4 suportes de parede no total: um para cada extremidade e dois no meio.

Suporte de parede alinhado com a linha horizontal Suporte de parede alinhado com a linha horizontal

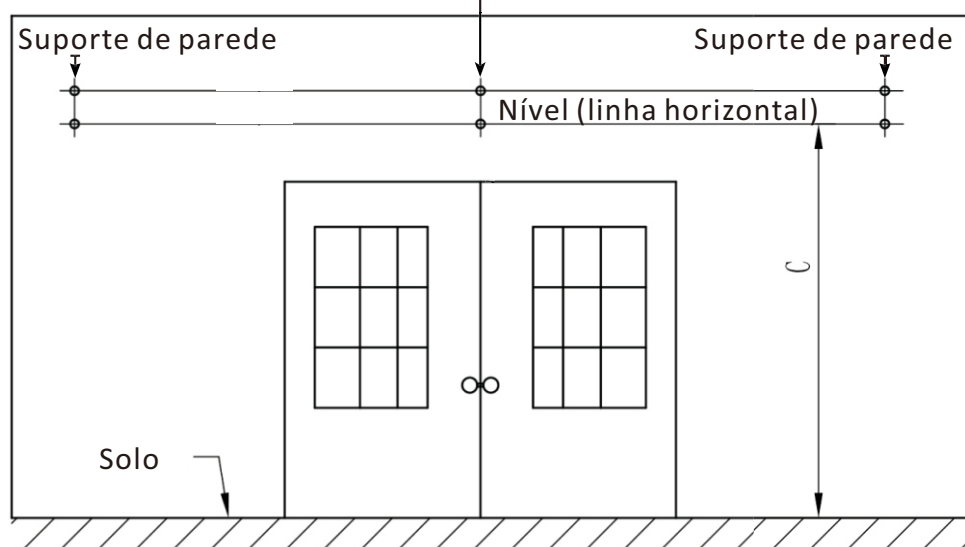

## PASSO 2: Perfurar os orifícios dos parafusos

1. Agora que tem uma linha reta e nivelada ao longo da parede com as localizações dos suportes de parede e os respectivos suportes marcados, faça os orifícios para montar os suportes.
2. Utilizando uma broca de 14 mm, faça o primeiro orifício com cerca de 9 centímetros de profundidade, como mostra o diagrama. Este deve ser feito através de tijolo sólido ou cimento para obter o suporte necessário para o toldo.
3. Faça os restantes orifícios exatamente como no passo 2.

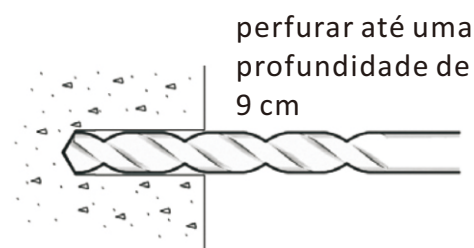

**!! IMPORTANTE:** Todos os orifícios dos parafusos devem estar alinhados na vertical e na horizontal para garantir que o toldo fica direito. Verificar novamente o alinhamento antes de perfurar se não tiver a certeza.

**!! IMPORTANTE:** O diâmetro e a profundidade dos seus orifícios de perfuração devem ser do mesmo tamanho que os parafusos de expansão.

### Passo 3: Preparação para a montagem

1. Agora que os orifícios estão perfurados, insira os parafusos de expansão.
2. Pode ser necessário introduzir os parafusos com um martelo de madeira (ou não metálico).



Se for necessário um martelo para a instalação, recomendamos que coloque a porca no parafuso (de forma solta) antes de martelar para evitar danificar as roscas do parafuso.

3. Certifique-se de que os parafusos estão bem colocados, mas deixe-os sobressair da parede cerca de 2,5 cm ou menos - o suficiente para que o suporte de parede possa ser instalado neles.

4. Aperte firmemente os parafusos com uma chave hexagonal de 19 mm. É preferível utilizar a chave hexagonal com uma extremidade fechada em vez de uma extremidade aberta para evitar danificar a porca caso esta escorregue.

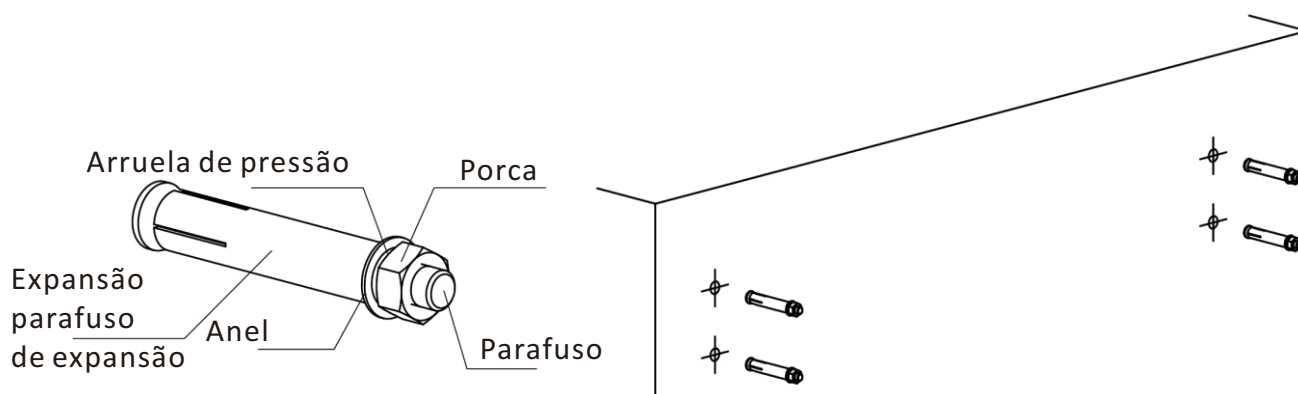

### PASSO 4: Montagem dos suportes de parede

1. Agora que os parafusos estão fixos na parede, retire as porcas que estão colocadas de forma solta sobre os parafusos.
2. Coloque um suporte de parede num conjunto de parafusos. Isto deve ser um encaixe se os orifícios dos parafusos estiverem corretamente alinhados.
3. Quando o suporte de parede estiver assente nos parafusos, coloque uma anilha sobre o parafuso e, em seguida, fixe-o com uma porca, como se mostra no diagrama.
4. Os suportes DEVEM ficar bem fixos na parede. Se houver algum movimento, é necessário apertar mais.
5. Repita este passo para cada um dos suportes de parede. Assim que o fizer, todos os suportes de parede estarão firmemente colocados no sítio.

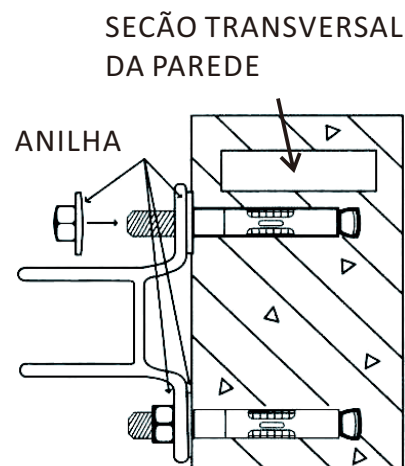

## PASSO 5: Montagem do toldo

1. Agora que os suportes de parede estão seguros e no lugar, é hora de instalar o toldo nos suportes.
2. São necessárias pelo menos duas escadas ou cadeiras para instalar o toldo.
3. Coloque os parafusos de expansão originais nos suportes de parede e aperte-os.
4. Por fim, apertar todos os parafusos de expansão.
5. Utilizando a manivela manual ou um motor (se aplicável), abra totalmente o toldo. A barra frontal deve estar nivelada.
6. Parabéns! O seu toldo está instalado. Se estiver satisfeito com a altura ou com a barra dianteira (inclinação do toldo), sente-se e desfrute! Caso contrário, continue a ler.

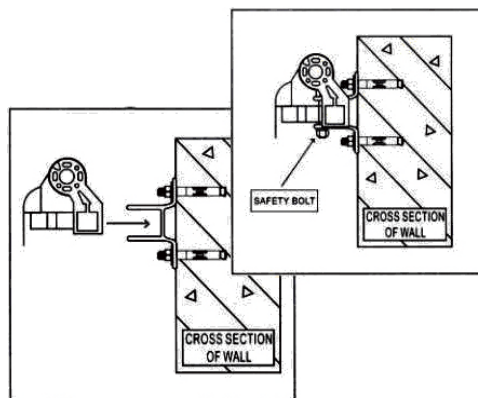

## 😊 INSTALAÇÃO OPCIONAL

### AJUSTAR A INCLINAÇÃO/ÂNGULO DO TOLDO

Cada toldo vem com um ângulo pré-definido (ângulo) que é considerado ideal. No entanto, se for necessário efetuar um ajuste, este pode ser feito em apenas alguns passos simples.

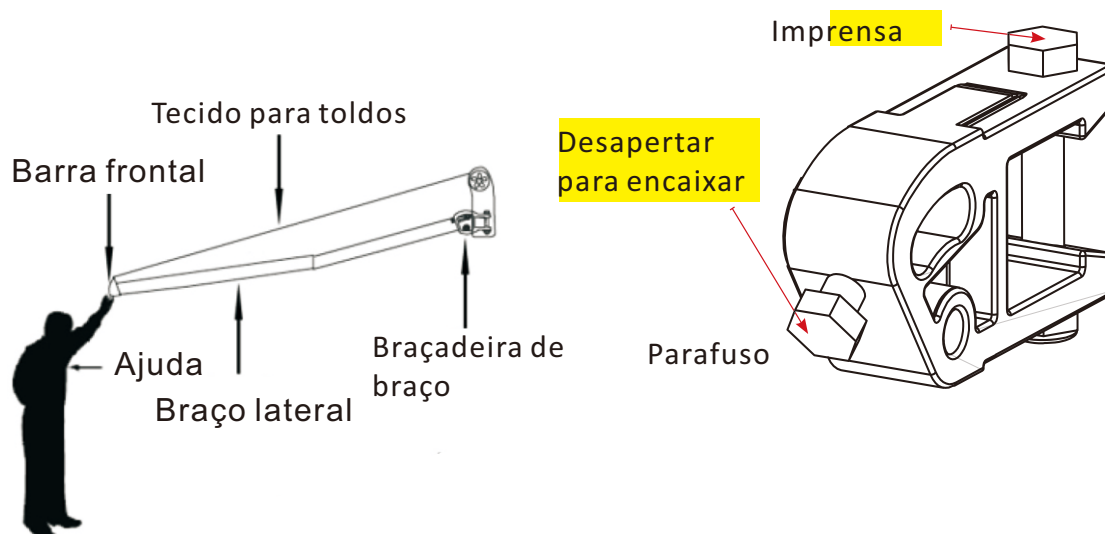

**!! IMPORTANTE:** Ao elevar a barra dianteira, o ângulo do tecido será reduzido, aumentando assim o risco de acumulação de água da chuva no tecido. Para evitar que o toldo se desmorone devido ao peso da água da chuva, deve recolher o toldo quando não estiver a ser utilizado. Se não o fizer, o toldo pode partir-se ou causar ferimentos pessoais

**Nota:** Certifique-se de que a barra frontal está ajustada de forma a ficar completamente nivelada. Qualquer desalinhamento resultará numa retração incorreta.

## Erros comuns

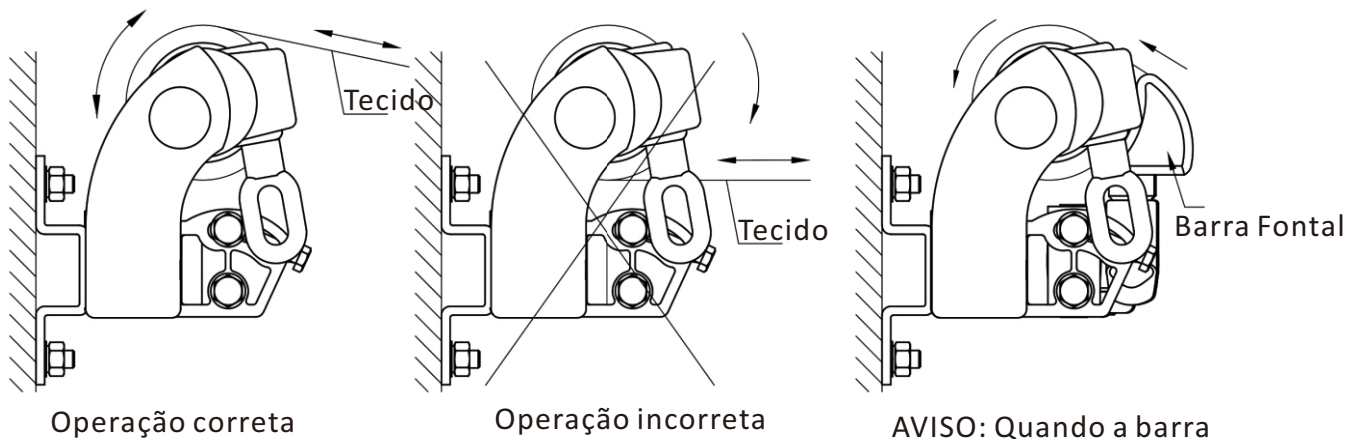





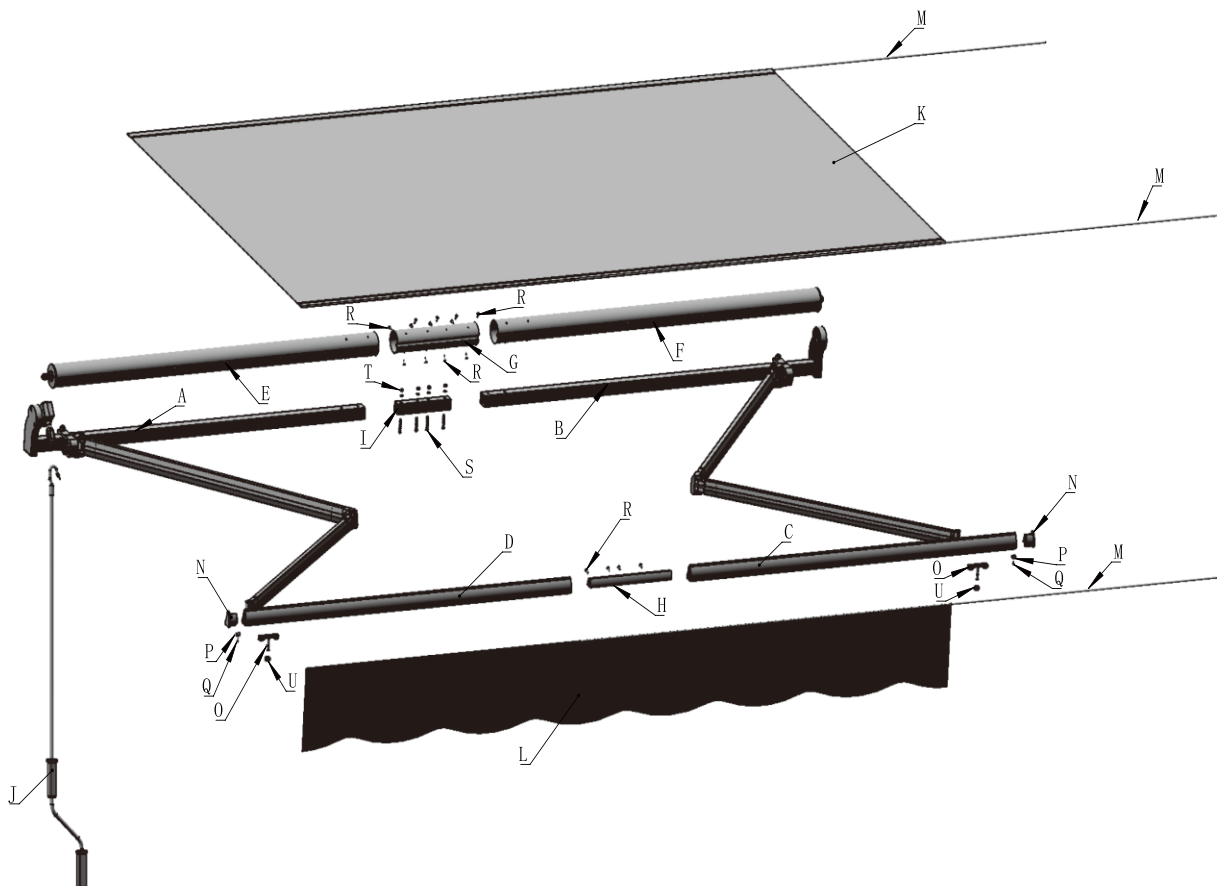



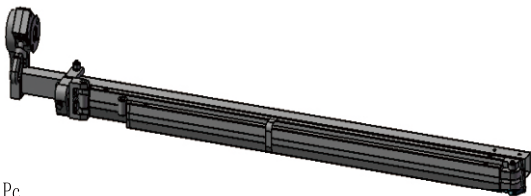
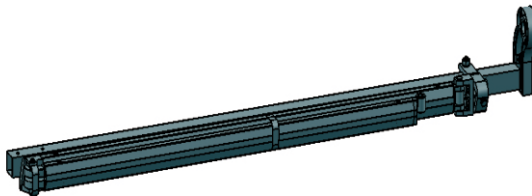



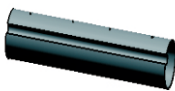

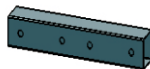

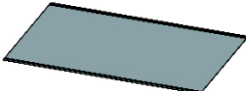







**AVISO:** Quando a barra frontal toca no rolo, como mostra a figura, não tente aproximá-los, caso contrário o produto pode ficar danificado.

- A. Torsionsstab mit Arm (Links)
- B. Torsionsstab mit Arm (Rechts)
- C. Vordere Stange (Rechts)
- D. Vordere Stange (Links)
- E. Rolle (Links)
- F. Rolle (Rechts)
- G. Rollenverbindung
- H. Vordere Stangenverbindung
- I. Torsionsstabverbindung
- J. Handkurbel
- K. Stoff
- L. Volant
- M. Stoffeinlage
- N. Vordere Stangenkappen (Links und Rechts)
- O. Armstangenverbindung
- P. Kunststoffbolzen für Abdeckung und Stoffeinlage
- Q. St 3 × 10
- R. St 14 × 15
- S. M6 × 40
- T. M6
- U. M10
- V. M8 × 55
- W. M8
- X. Expansionschraube
- Y. Wandhalterungen



TEILELISTE

 <p>A 1Pc</p>		 <p>B 1Pc</p>					
 <p>C 1Pc</p>		 <p>D 1Pc</p>					
 <p>E 1Pc</p>		 <p>F 1Pc</p>					
 <p>G 1Pc</p>	 <p>H 1Pc</p>	 <p>I 1Pc</p>	 <p>J 1Pc</p>				
 <p>K 1Pc</p>	 <p>L 1Pc</p>	 <p>M 3Pc</p>	 <p>N 2Pcs</p>	 <p>O 2Pcs</p>			
 <p>P 2Pcs</p>	 <p>Q 2Pcs</p>	 <p>R 16Pcs</p>	 <p>S 4Pcs</p>	 <p>T 4Pcs</p>	 <p>U 2Pcs</p>	 <p>V 2Pcs</p>	 <p>W 2Pcs</p>
 <p>X 4Pcs</p>	 <p>Y 2Pcs</p>	 <p>Z 4Pcs</p>					

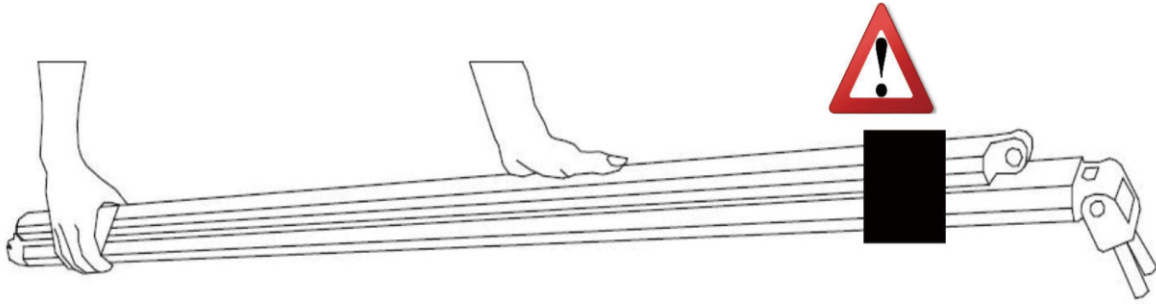

**WARNUNG!  
MARKISENARME KÖNNEN  
VERLETZUNGEN VERURSACHEN!**

**SCHNEIDEN SIE DIE BÄNDER DER  
MARKISENARME ERST DURCH, WENN  
DIE MARKISE VOLLSTÄNDIG MONTIERT  
IST!!!**

**- ALEKO TEAM**

**X Falsch**



**✓ Rechts**



**WARNUNG  
KANN ZU VERLETZUNGEN FÜHREN!  
ERST NACH VOLLSTÄNDIGER MONTAGE  
DURCHSCHNEIDEN**

SCHRITT 1: Fädeln Sie die Stoffeinlage ein, und schneiden Sie die Stoffeinlage so lang wie der Stoff

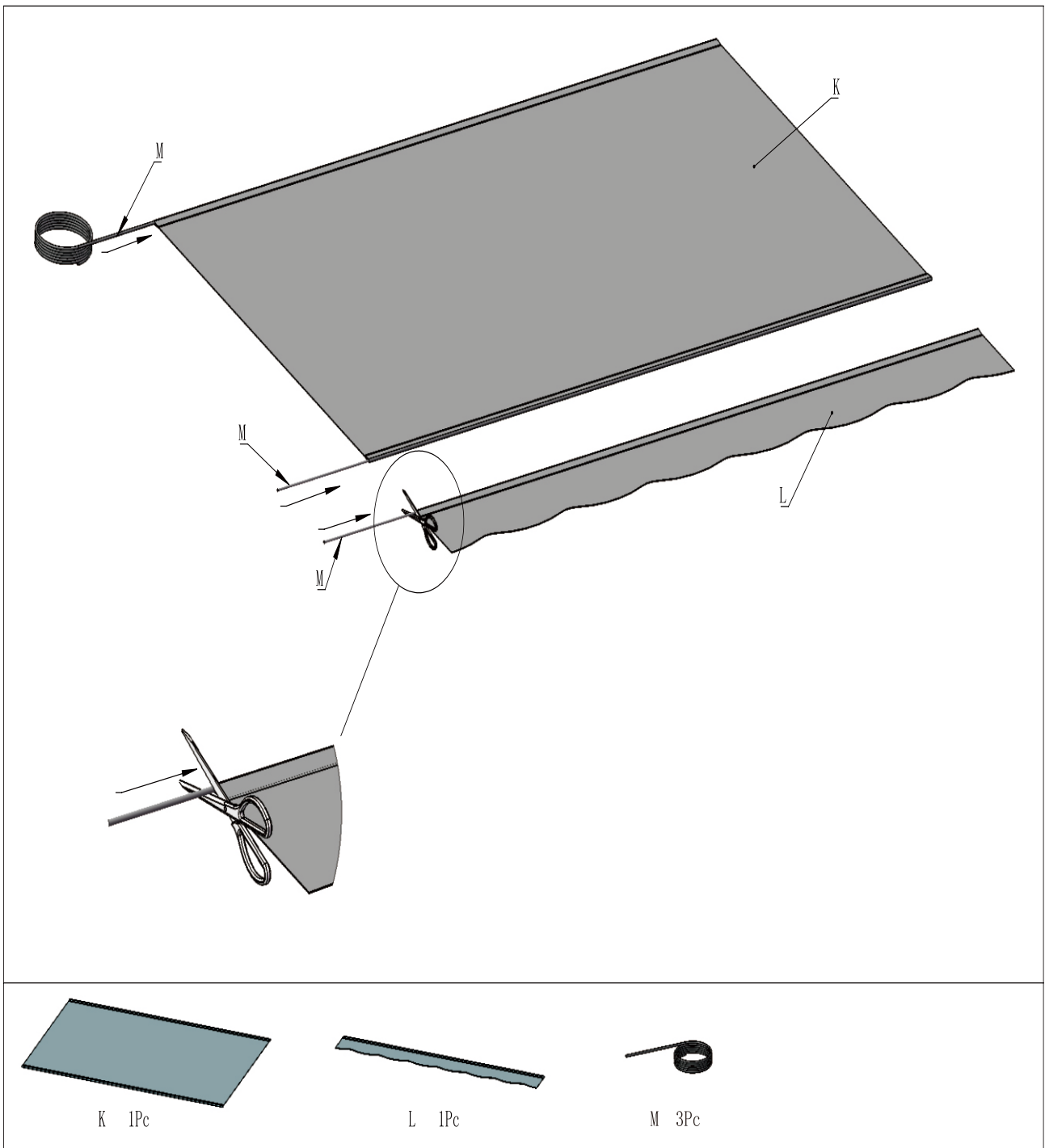

### SCHRITT 2: Verbindung von Rollenrohr und Vorderstange (LINKS)

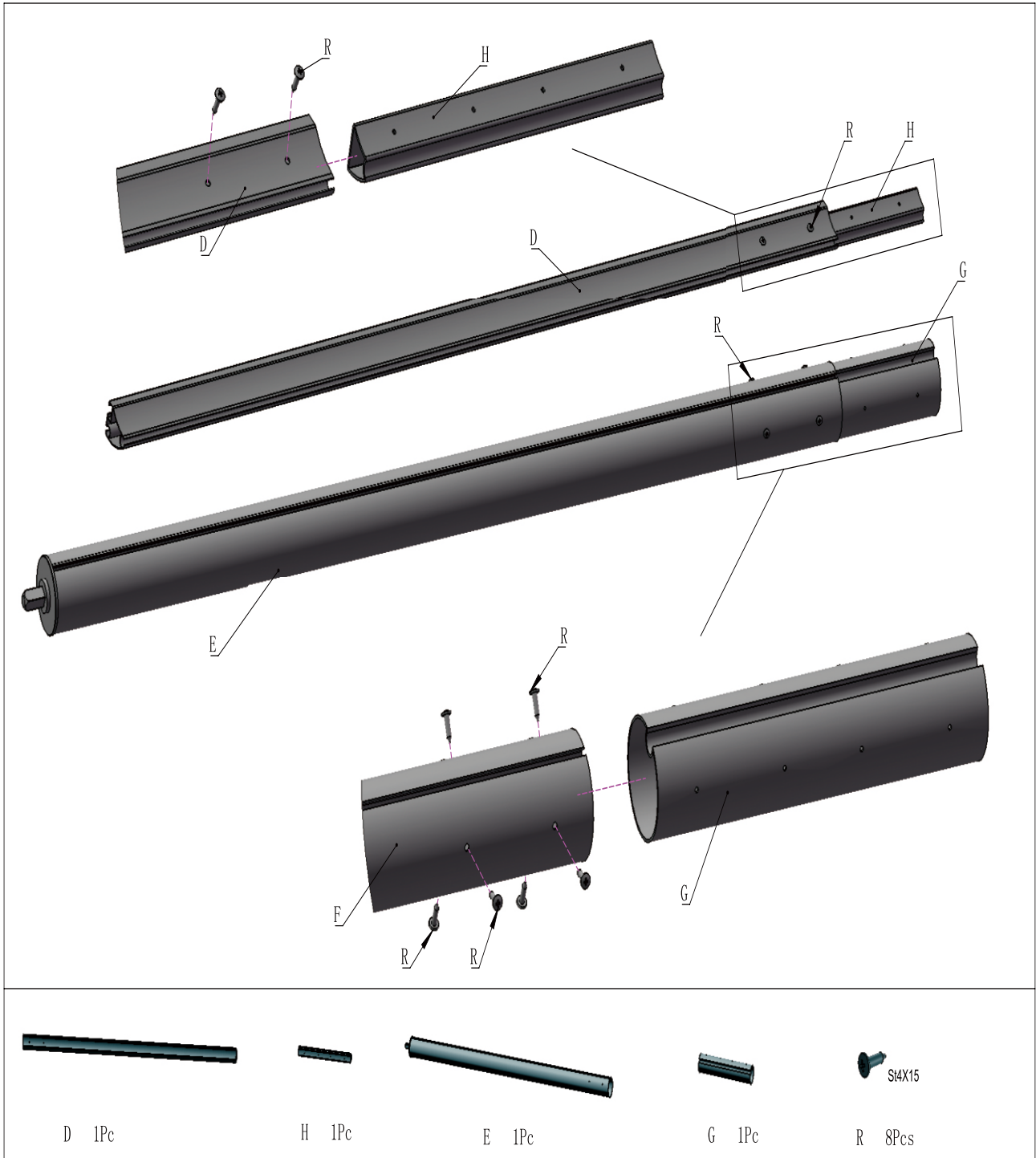

### PASSO 3: Montaggio del tessuto e collegamento del rullo e della barra anteriore

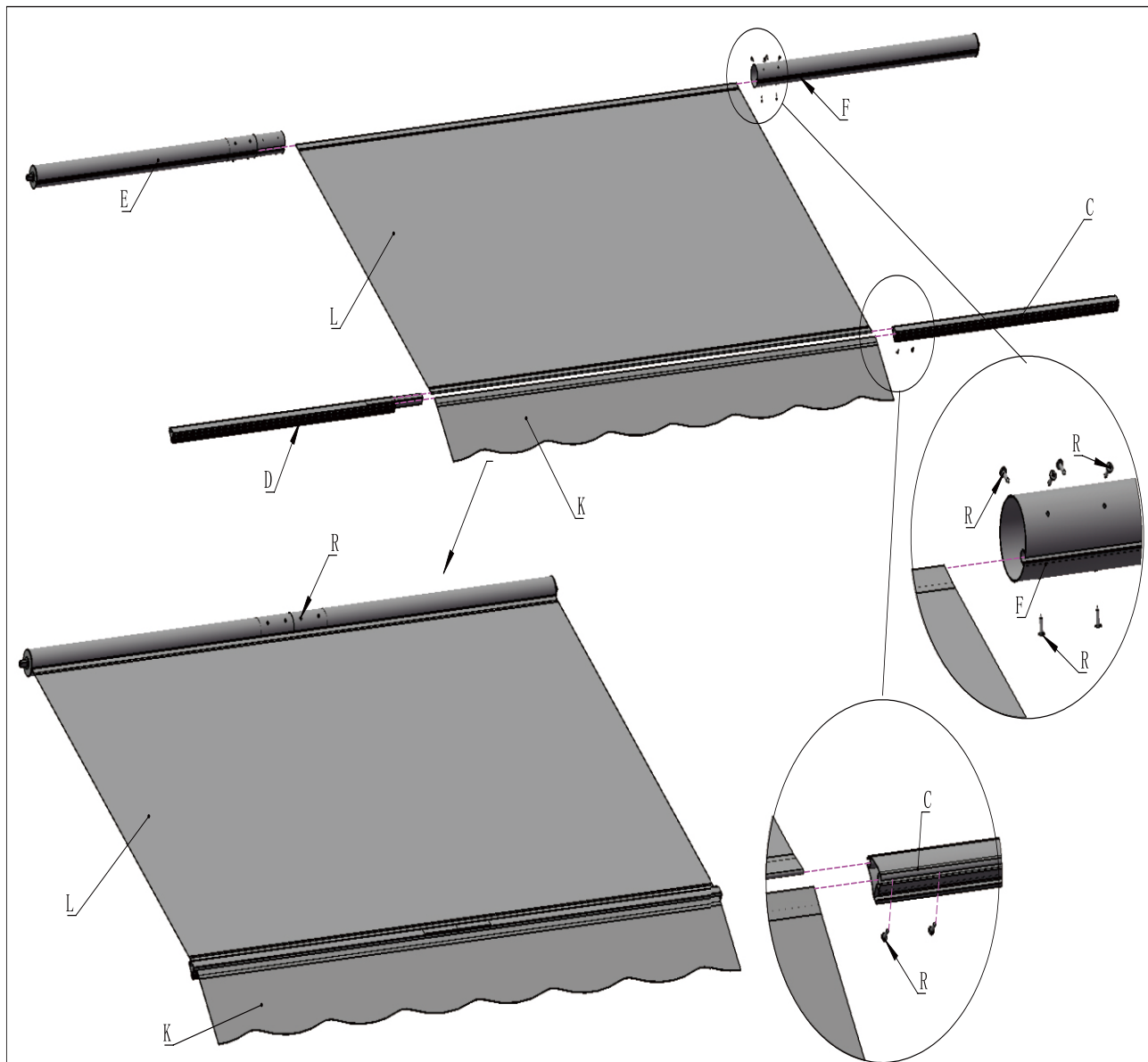

**SCHRITT 4:** 1. Stecken Sie die Armstangenverbindung in die vordere Stange  
2. Setzen Sie das Teil P in die vordere Stange und verriegeln Sie es mit der Schraube Q  
3. Klopfen Sie auf die der vorderen Stangenkappe

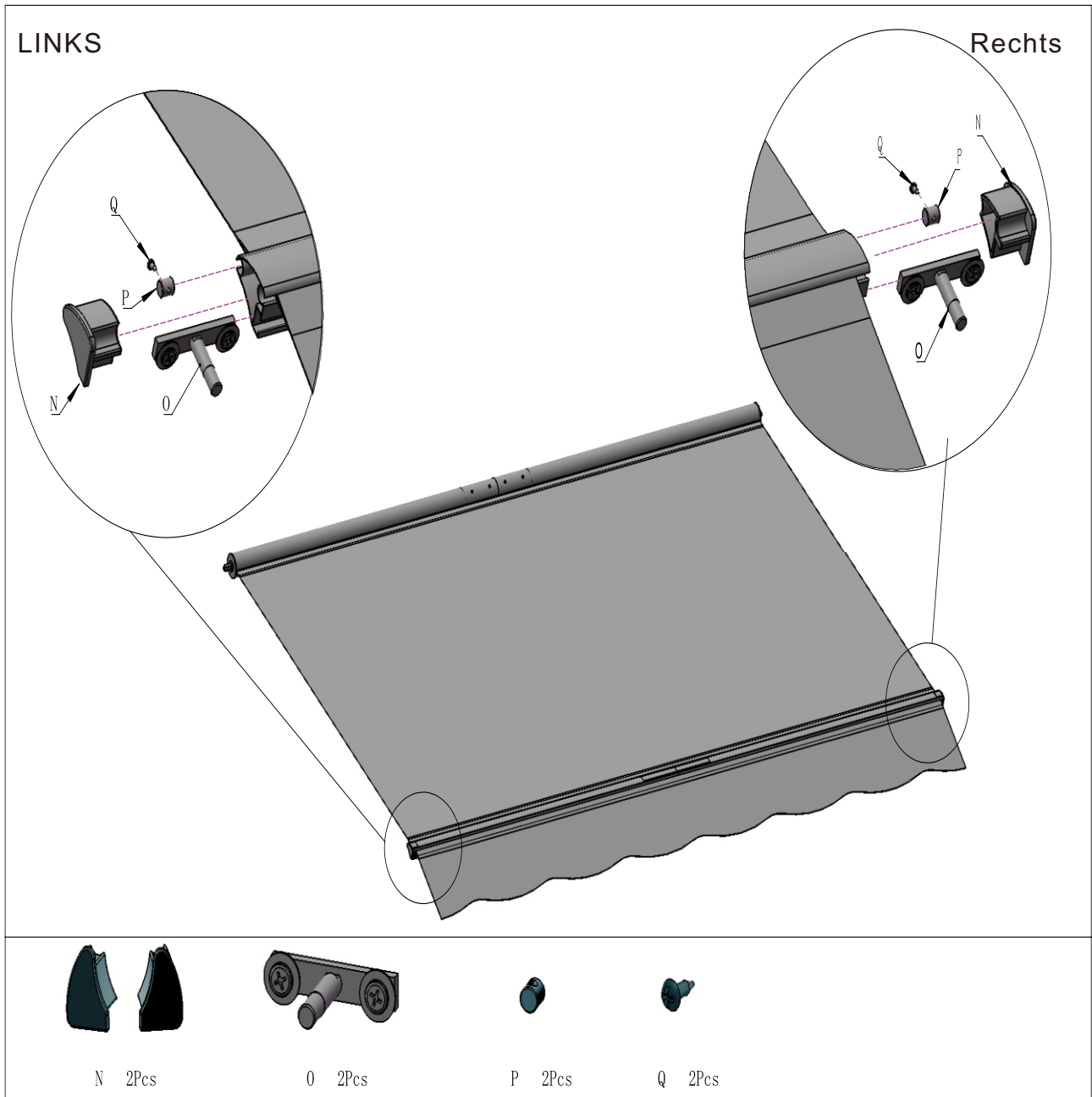

SCHRITT 5: Rollen Sie das Markisentuch so straff wie möglich auf

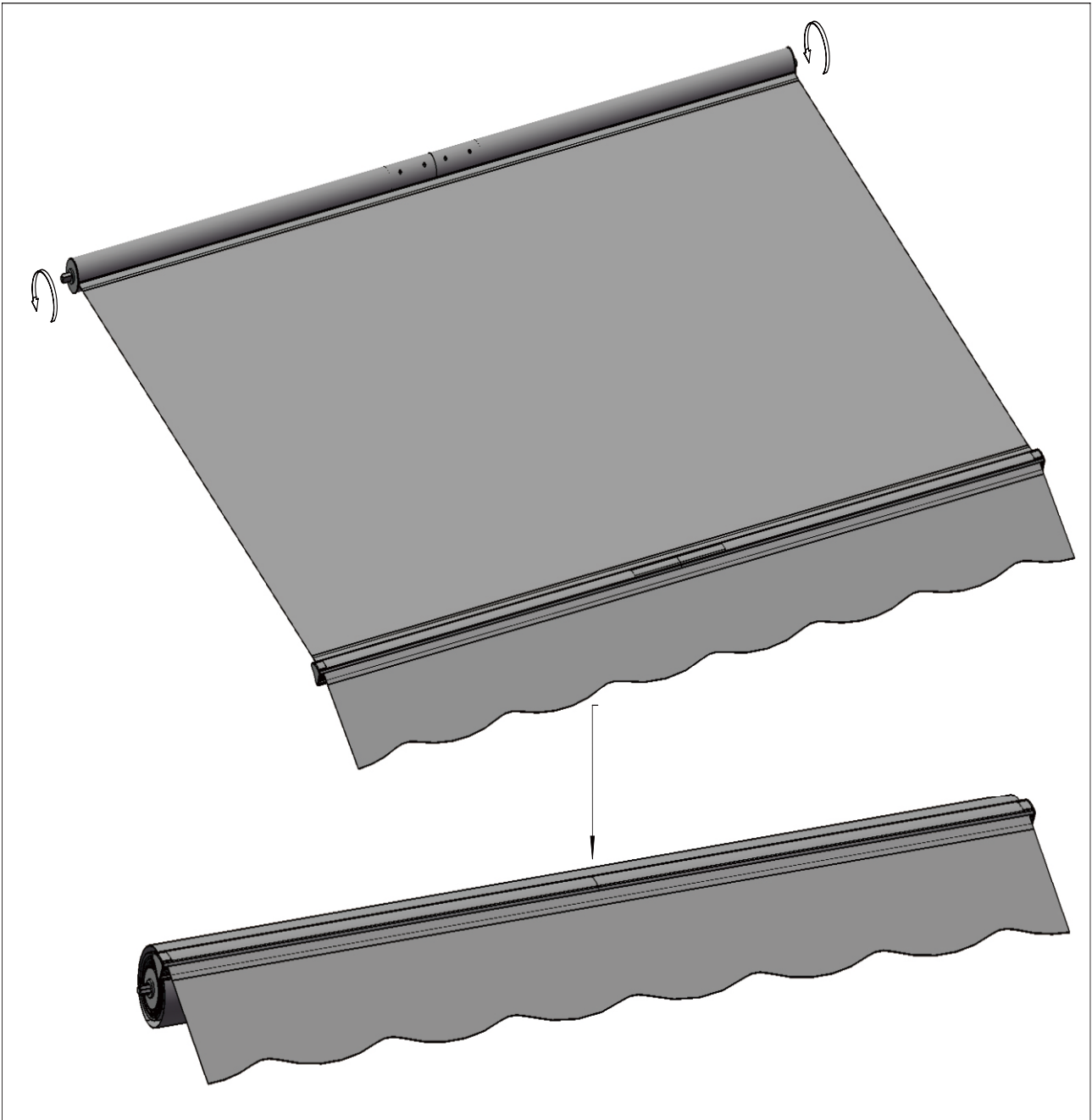

- SCHRITT 6: 1. Verbinden Sie den Torsionsstab und verschrauben Sie ihn später  
 2. Stecken Sie die Rolle in das viereckige Loch des Zahnradkastens und das runde Quadrat der Rollenhalterung  
 3. Verbinden Sie die beiden Torsionsstab und verschrauben Sie sie

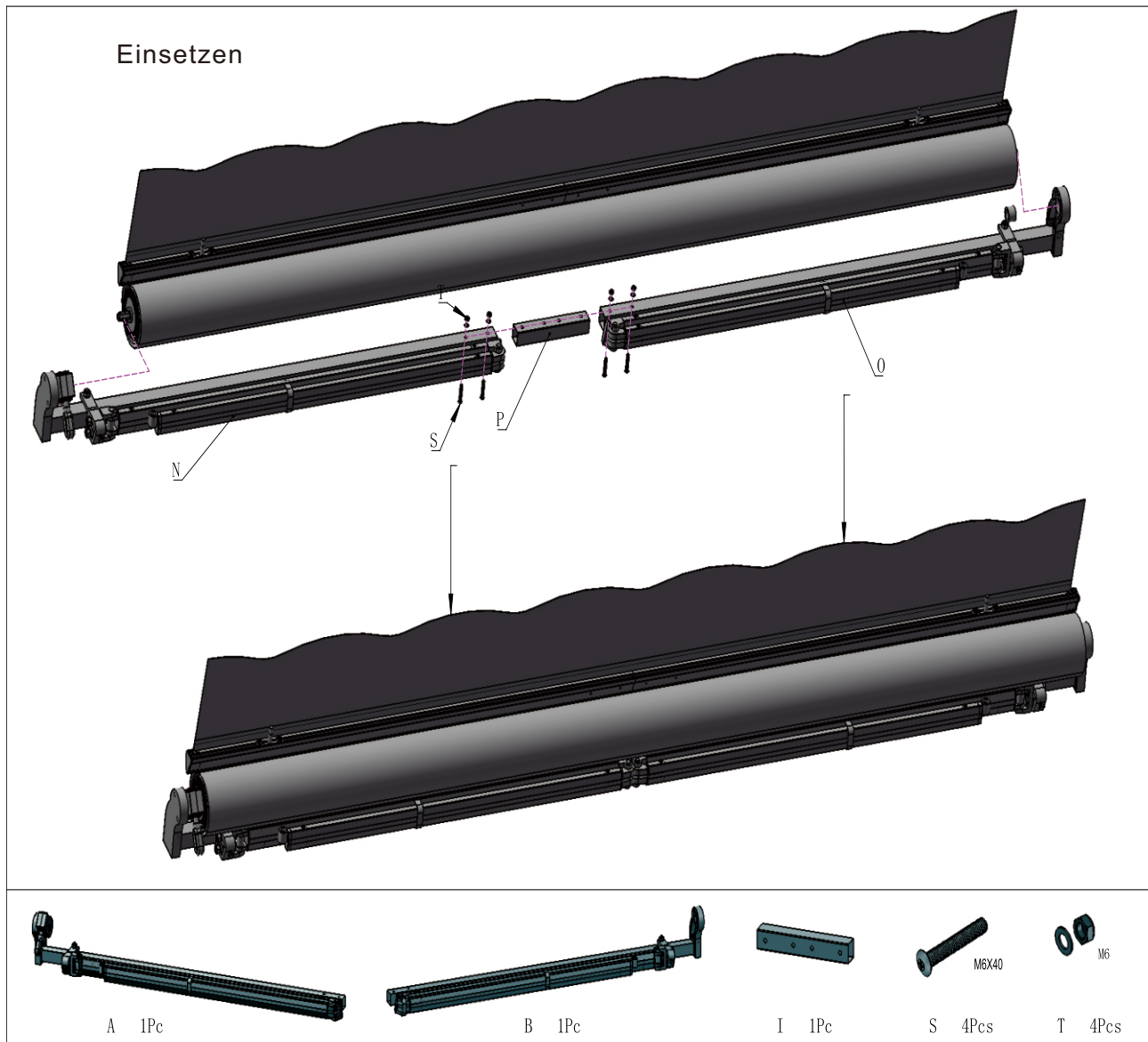

## SCHRITT7: Einstellen der Markisenposition

1. Bewegen Sie die Armverbindung, bis die vordere Stange mit dem Gelenkkopf angeschlossen ist.
2. Richten Sie die Stange und den Arm aus und ziehen Sie das O-Teil fest
3. Ziehen Sie dann den verstellbaren Bolzen U bis zu 90 % fest

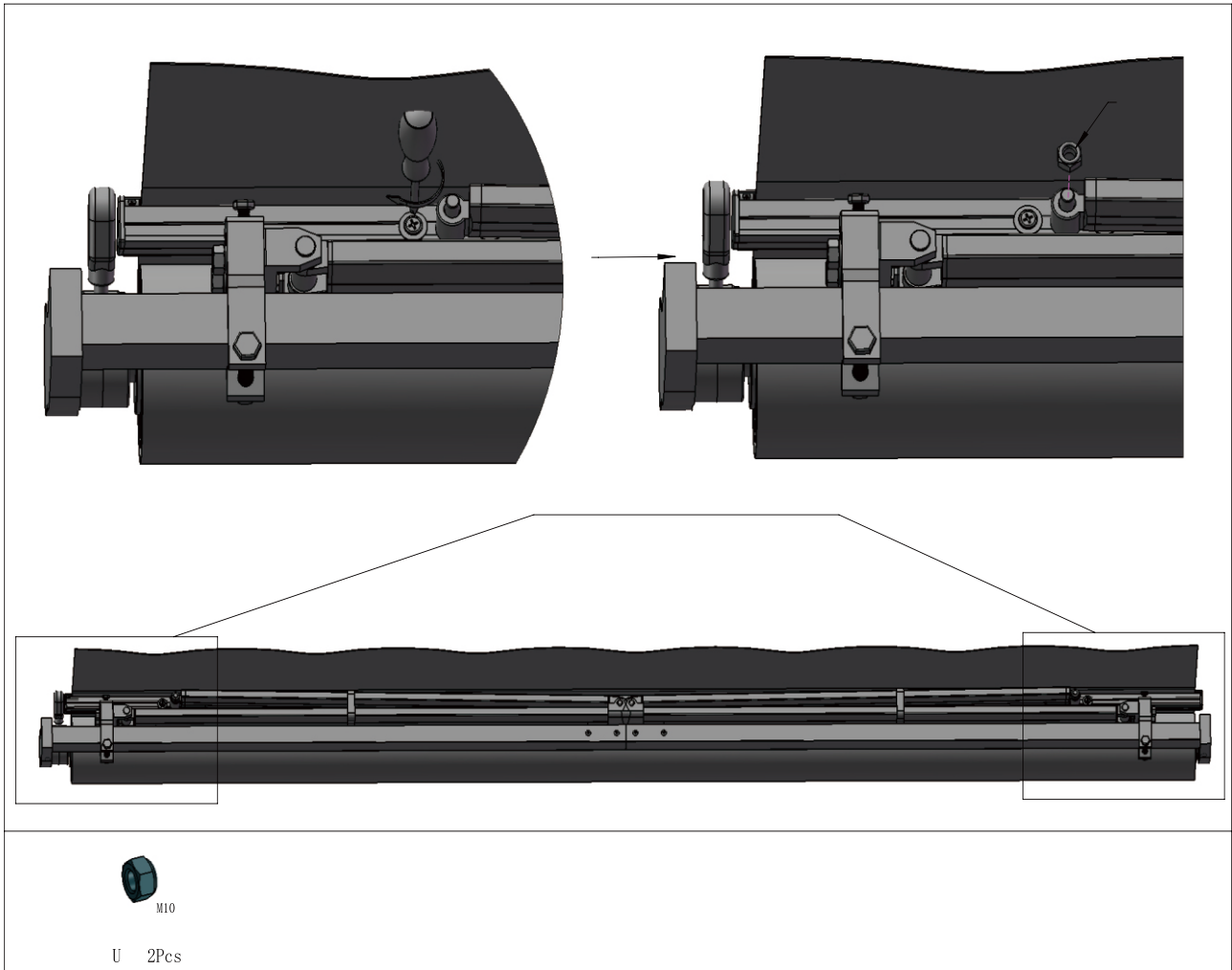

**SCHRITT 8: Fertigstellung des Zusammenbaus der Markise**

1. Sie können die Sicherungsbänder, die den Arm und den Torsionsstab festhalten, durchschneiden. Der Zusammenbau der Markise ist abgeschlossen.
2. Fahren Sie nun mit dem Abschnitt über die Wandbefestigung fort.

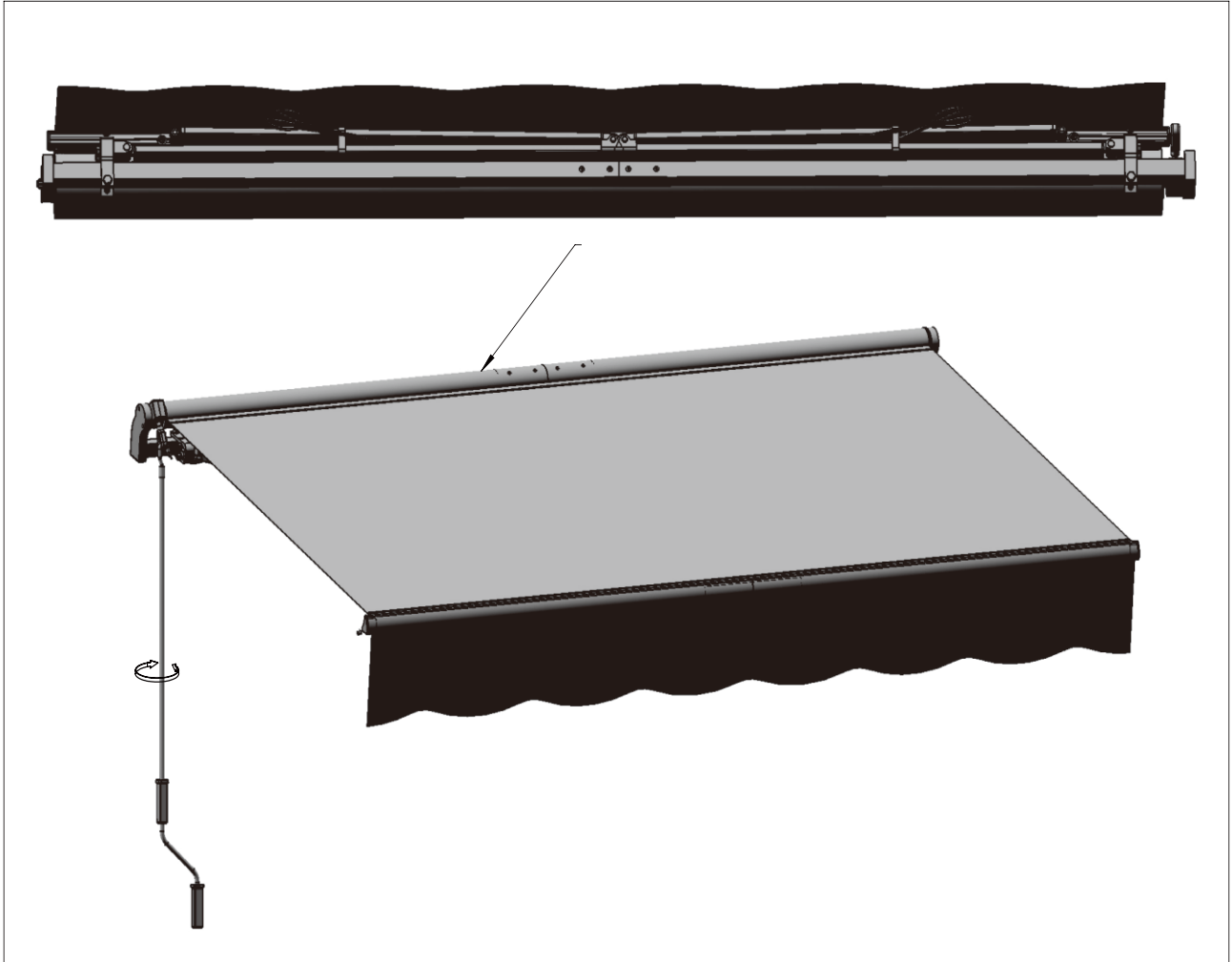

## 🔧 INSTALLATION

### Hinweise zur Anbringung an der Wand

Diese Markise kann an Stahlbeton, Ziegeln und Holz befestigt werden. In diesem Markisenbausatz sind jedoch nur Schrauben enthalten, die für die Befestigung an Ziegel- und Stahlbetonwänden geeignet sind.

Wenn Sie Ihre Markise an Holz befestigen möchten, verwenden Sie bitte Bolzen von ausreichender Länge und mit einem geeigneten Durchmesser, um die Markise an Holzbalken zu befestigen. Das Format der Bolzen hängt vom Format des Holzes ab; diese können Sie in einem Baumarkt erwerben. Wir empfehlen einen professionellen Installateur für den sichersten Einbau.

**Versuchen Sie niemals, die Wandhalterungen an Steinen oder anderen Oberflächen zu befestigen, die nicht absolut fest sind!**



**ACHTUNG:** Die ordnungsgemäße Befestigung der Wandhalterungen ist das wichtigste Kriterium für eine schnelle Montage der Wandhalterungen an Bolzen, Pfosten, Dachbalken oder anderen wichtigen Bauteilen.



**WARNUNG:** Wenn Sie nicht alle Halterungen sicher an der Wand befestigen, kann die Markise einstürzen und zu Verletzungen oder zum Tod führen.

### Montagehöhe

Es ist wichtig, den Neigungsbereich der Markise zu berücksichtigen, bevor Sie Ihre Wandhalterungen anschrauben. Wenn Sie die Markise z.B. über einer Terrassentür montieren möchten, lassen Sie bitte mindestens 8 Zoll über dem Türrahmen und stellen Sie sicher, dass die Markise das Öffnen und Schließen der Tür nicht behindert. Der Neigungswinkel kann nur geringfügig verändert werden. Berücksichtigen Sie dies also bei der Entscheidung, wo Sie Ihre Markise anbringen möchten.

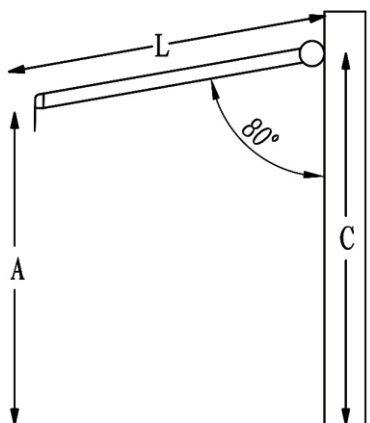

- **Empfohlene Montagehöhe:** 8 bis 12 Fuß.
- **Der ideale Neigungswinkel (bei vollständig ausgefahrener Markise) wurde bereits im Werk eingestellt**, so dass Sie die Neigung/den Winkel möglicherweise nicht ändern müssen.
- **Die Markise hat einen Neigungswinkel von 24 Zoll**, also 15 Grad.

### BERECHNUNGEN:

Sie können die folgende Formel verwenden, um den entsprechenden Winkel zu berechnen.

$$C = A + 0,17 \times L$$

A = Die gewünschte Höhe der vorderen Stange

L = Die Länge des ausgestreckten Arms

C = Die Höhe der Wandhalterung

*Wir empfehlen, dass die Markisenfläche im geöffneten Zustand einen Winkel von etwa 80 Grad zur Wand bildet.*

### SCHRITT 1: Ausmessen des Montageortes

1. Messen Sie die Länge Ihrer Markise entlang der Wand, an der Sie sie montieren möchten. Diese Linie wird der höchste Punkt Ihrer Markise sein und mit der Oberkante der Wandhalterung übereinstimmen. Verwenden Sie eine Wasserwaage, um eine Kreidelinie über die Strecke zu ziehen.

**2. Wichtig: Prüfen Sie, ob die Linie durchgängig waagrecht ist.**

3. Achten Sie darauf, dass die Linie mittig über der Terrassentür, dem Fenster oder, falls zutreffend, einem anderen Element verläuft.

4. Jetzt, wo Sie eine gerade, zentrierte Linie haben, messen Sie den Mittelpunkt und markieren ihn. An dieser Stelle wird die mittlere Wandhalterung montiert.

5. Nehmen Sie eine Wandhalterung und platzieren Sie die Oberseite der Halterung völlig waagrecht unter der Linie, wie in der Abbildung unten gezeigt. Markieren Sie mit Kreide oder einem Bleistift die Position aller Wandhalterungen und deren Bolzenlöcher.

Markisen <10,8 Fuß	Erfordert insgesamt nur 2 Wandhalterungen: eine für jedes Ende der Torsionsstab.
Markisen 10,8 bis 14 Fuß	Erfordert insgesamt 3 Wandhalterungen: eine für jedes Ende und eine in der Mitte.
Markisen 14,5 bis 20 Fuß	Benötigt insgesamt 4 Wandhalterungen: eine für jedes Ende und zwei in der Mitte.

Wandhalterung an der horizontalen Linie ausrichten

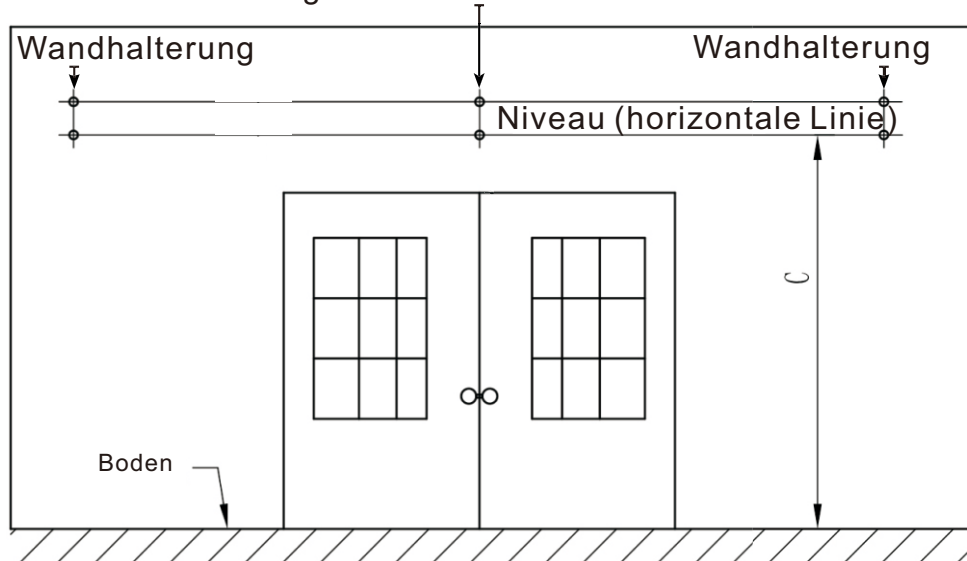

### SCHRITT 2: Bohren der Löcher für die Bolzen

1. Nachdem Sie nun eine gerade, ebene Linie über die Wand gezogen und die Positionen der Wandhalterungen und ihrer Bolzenlöcher markiert haben, bohren Sie die Löcher für die Montage der Halterungen.

2. Verwenden Sie einen 14-mm-Mauerbohrer und bohren Sie das erste Bolzenloch etwa 9 cm (4 Zoll) tief, wie in der Abbildung gezeigt. Dieses Loch muss durch soliden Ziegelstein oder Beton gebohrt werden, um der Markise den nötigen Halt zu geben.

3. Bohren Sie die restlichen Löcher genau wie in Schritt 2.

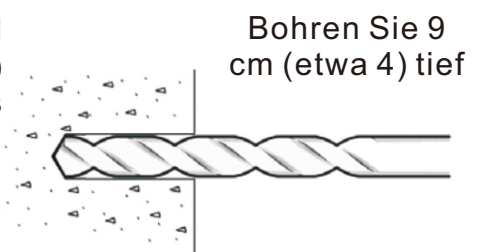

**!! WICHTIG:** Alle Bolzenlöcher müssen vertikal und horizontal ausgerichtet sein, um sicherzustellen, dass die Markise gerade hängt.

**Prüfen Sie die Ausrichtung vor dem Bohren, wenn Sie sich nicht sicher sind. WICHTIG:** Der Durchmesser und die Tiefe der Befestigungslöcher

**!!** müssen mit dem Format der Expansionsbolzen übereinstimmen.

### SCHRITT 3: Vorbereitungen für die Montage

1. Nachdem Sie nun alle Löcher gebohrt haben, setzen Sie die Expansionsbolzen ein.
2. Möglicherweise müssen Sie die Bolzen mit einem Holzhammer (oder einem anderen nicht-metallischen Hammer) einschlagen.



*Wenn ein Hammer für den Einbau erforderlich ist, empfehlen wir, die Mutter vor dem Einschlagen (lose) auf die Schraube zu setzen, um eine Beschädigung der Bolzengewinde zu vermeiden.*

3. Stellen Sie sicher, dass die Bolzen festsitzen, aber noch etwa 1 Zoll oder weniger aus der Wand herausragen - genug, dass die Wandhalterung darauf montiert werden kann.
4. Ziehen Sie die Bolzen mit einem 19-mm-Sechskantschlüssel fest. Verwenden Sie am besten einen Sechskantschlüssel mit einem geschlossenen Ende und nicht mit einem offenen Ende, damit die Mutter nicht beschädigt wird, falls sie abrutscht.

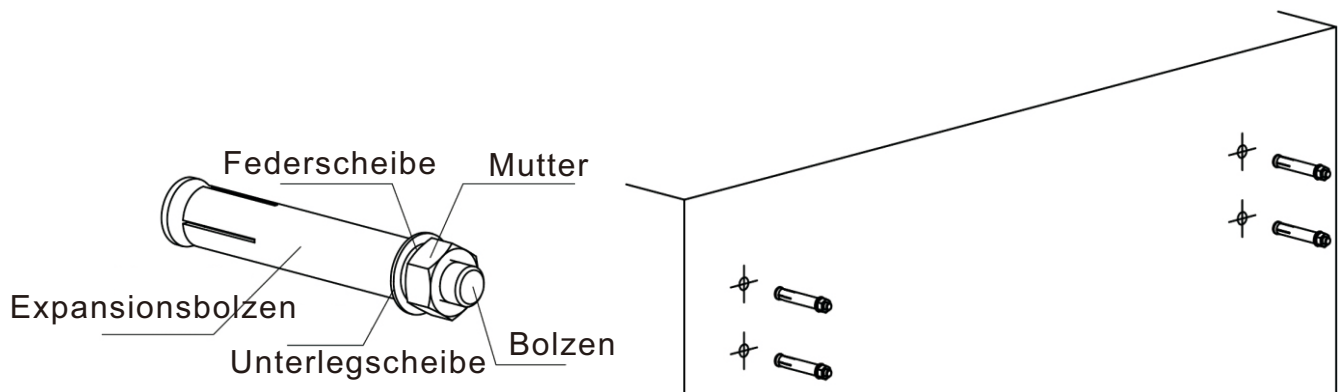

### SCHRITT 4: Montage der Wandhalterungen

1. Nachdem die Bolzen nun fest in der Wand sitzen, entfernen Sie die Muttern, die lose auf den Bolzen sitzen.
2. Setzen Sie eine Wandhalterung auf einen Satz Bolzen. Wenn die Löcher für die Bolzen richtig ausgerichtet sind, sollte dies ein Kinderspiel sein.
3. Sobald die Wandhalterung auf den Bolzen aufliegt, legen Sie eine Unterlegscheibe über den Bolzen und sichern ihn dann mit einer Mutter, wie in der Abbildung gezeigt.
4. **Die Halterungen MÜSSEN fest auf der Wand sitzen.** Wenn sie sich bewegen, müssen Sie sie noch fester festziehen.
5. Wiederholen Sie diesen Schritt für jede der Wandhalterungen. Sobald Sie dies getan haben, sind alle Wandhalterungen sicher an ihrem Platz.

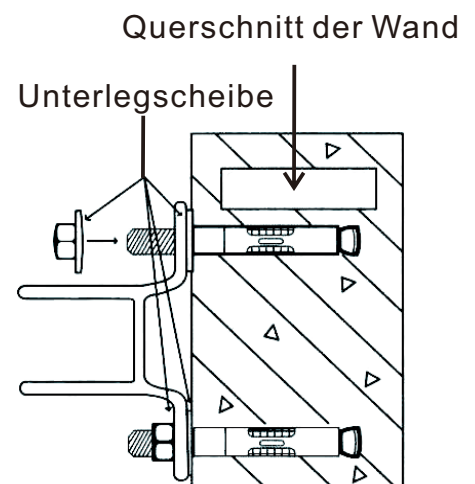

### SCHRITT 5: Montage der Markise

1. Jetzt, da die Wandhalterungen sicher und an ihrem Platz sind, ist es an der Zeit, die Markise an den Halterungen zu montieren.
2. Für die Montage der Markise benötigen Sie mindestens zwei Leitern oder stabile Stühle.
3. Setzen Sie die originalen Expansionsbolzen auf die Wandhalterungen und ziehen Sie sie fest.
4. Ziehen Sie schließlich alle Expansionsbolzen an.
5. Verwenden Sie die Handkurbel oder einen Motor (falls vorhanden), um Ihre Markise vollständig zu öffnen. Die vordere Stange sollte waagrecht sein.
6. **Herzlichen Glückwunsch! Ihre Markise ist montiert. Wenn Sie mit der Höhe der vorderen Stange (Markisenneigung) zufrieden sind, können Sie sich zurücklehnen und genießen! Wenn nicht, lesen Sie bitte weiter.**

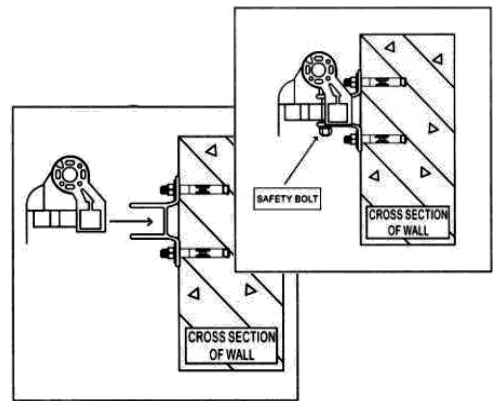

### ☺ OPTIONALE MONTAGE

#### ANPASSUNG DER MARKISENNEIGUNG/DES NEIGUNGSWINKELS

Jede Markise wird mit einer voreingestellten Neigung (Winkel) geliefert, die als ideal angesehen wird. Wenn Sie jedoch eine Anpassung vornehmen möchten, können Sie dies in wenigen einfachen Schritten tun.

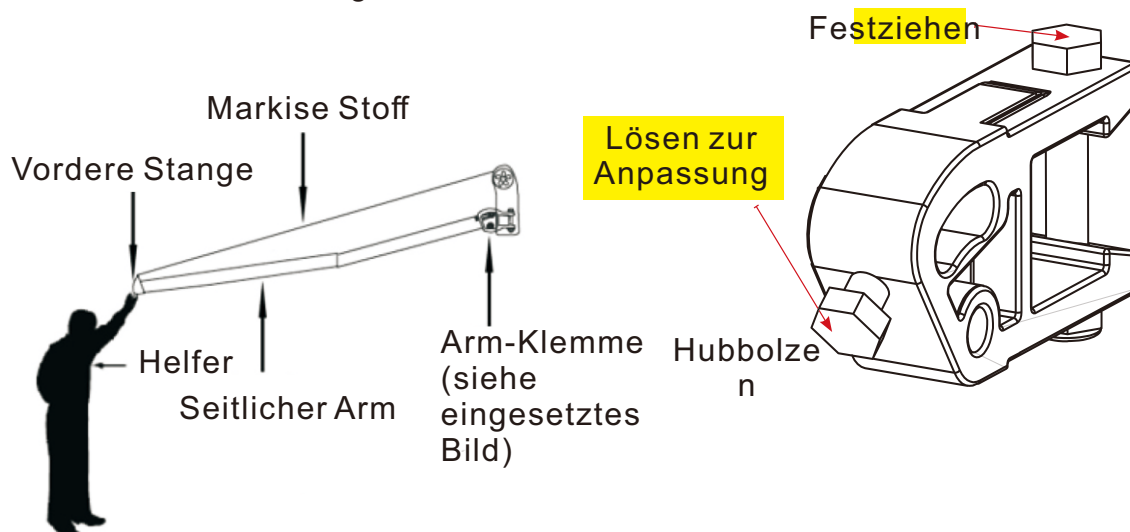

- !! **WICHTIG:** Wenn Sie die vordere Stange anheben, verringert sich der Neigungswinkel der Markise, wodurch sich das Risiko erhöht, dass Regenwasser auf das Tuch läuft. Um zu verhindern, dass die Markise durch das Gewicht des Regenwassers zusammenbricht, müssen Sie die Markise einfahren, wenn Sie unbeaufsichtigt sind. Wenn Sie dies nicht tun, kann die Markise beschädigt werden oder Sie können sich verletzen.

Hinweis: Vergewissern Sie sich, dass die vordere Stange völlig gleichmäßig ausgerichtet ist. Jede Fehlausrichtung führt dazu, dass die Markise nicht richtig eingefahren wird.

Häufige Fehler

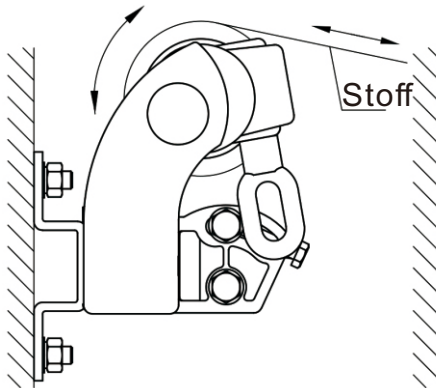

Richtige Bedienung

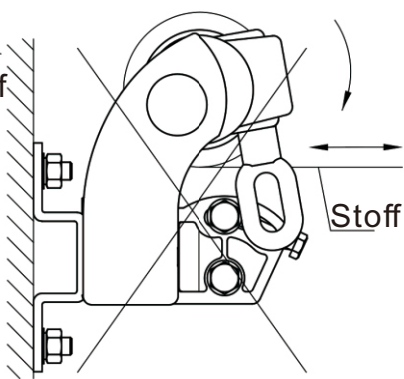

Falsche Bedienung

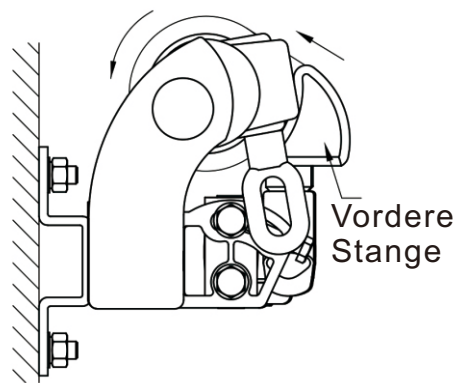





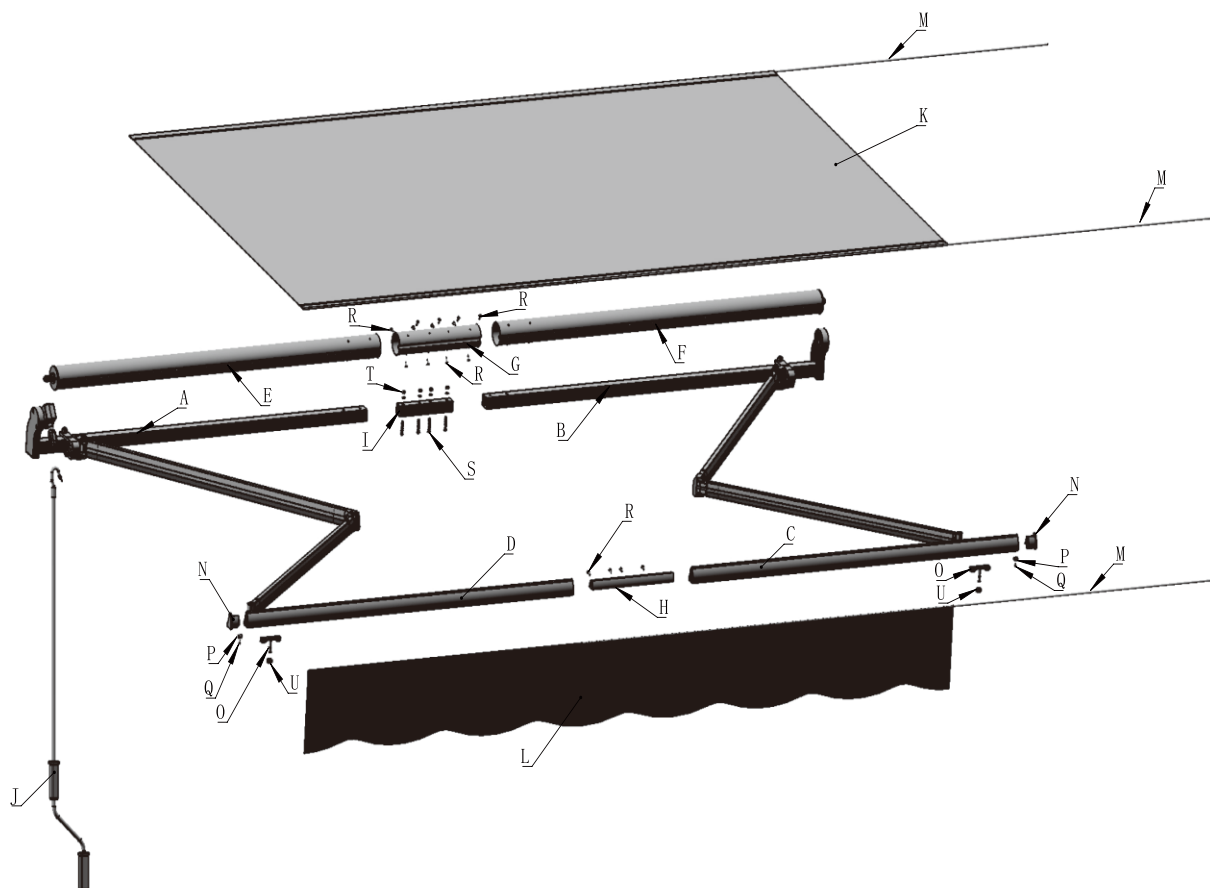



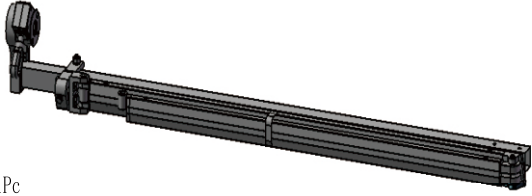
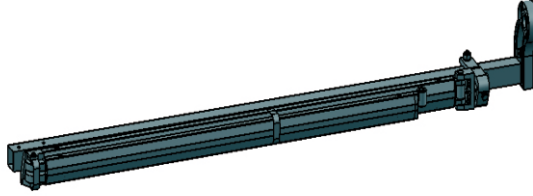



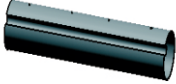

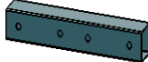

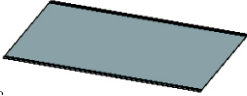







**WARNUNG:** Wenn die vordere Stange die Walze berührt, wie in der Abbildung gezeigt, versuchen Sie nicht, sie weiter anzunähern, da das Produkt sonst beschädigt werden kann.

- A. Barra di torsione con braccio (sinistra)
- B. Barra di torsione con braccio (destra)
- C. Barra anteriore (destra)
- D. Barra anteriore (sinistra)
- E. Rullo (sinistro)
- F. Rullo (destro)
- G. Connettore a rulli
- H. Connettore barra anteriore
- I. Connettore barra di torsione
- J. Manovella
- K. Tela
- L. Drappeggio
- M. Fodera in tessuto
- N. Tappi barra anteriore (sinistro e destro)
- O. Tirante braccio-barra
- P. Bullone in plastica per fodera in tessuto
- Q. St 3x10
- R. St 14x15
- S. M6X40
- T. M6
- U. M10
- V. M8X55
- W. M8
- X. Vite a espansione
- Y. Staffe a parete



ELENCO DEI COMPONENTI

 <p>A 1Pc</p>		 <p>B 1Pc</p>					
 <p>C 1Pc</p>		 <p>D 1Pc</p>					
 <p>E 1Pc</p>		 <p>F 1Pc</p>					
 <p>G 1Pc</p>	 <p>H 1Pc</p>	 <p>I 1Pc</p>	 <p>J 1Pc</p>				
 <p>K 1Pc</p>	 <p>L 1Pc</p>	 <p>M 3Pc</p>	 <p>N 2Pcs</p>	 <p>O 2Pcs</p>			
 <p>P 2Pcs</p>	 <p>Q 2Pcs</p>	 <p>R 16Pcs</p>	 <p>S 4Pcs</p>	 <p>T 4Pcs</p>	 <p>U 2Pcs</p>	 <p>V 2Pcs</p>	 <p>W 2Pcs</p>
 <p>X 4Pcs</p>	 <p>Y 2Pcs</p>	 <p>Z 4Pcs</p>					

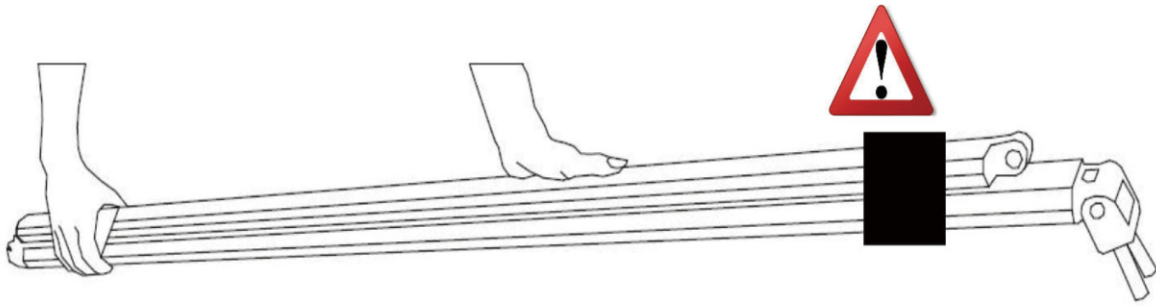

**AVVERTENZA!  
I BRACCI DELLA TENDA POSSONO  
CAUSARE LESIONI!**

**TAGLIARE I NASTRI DI BLOCCAGGIO  
DEI BRACCI DELLA TENDA SOLO DOPO  
AVER MONTATO COMPLETAMENTE LA  
TENDA!!!**

**- SQUADRA ALEKO**

**X sbagliato**



**✓ corretto**







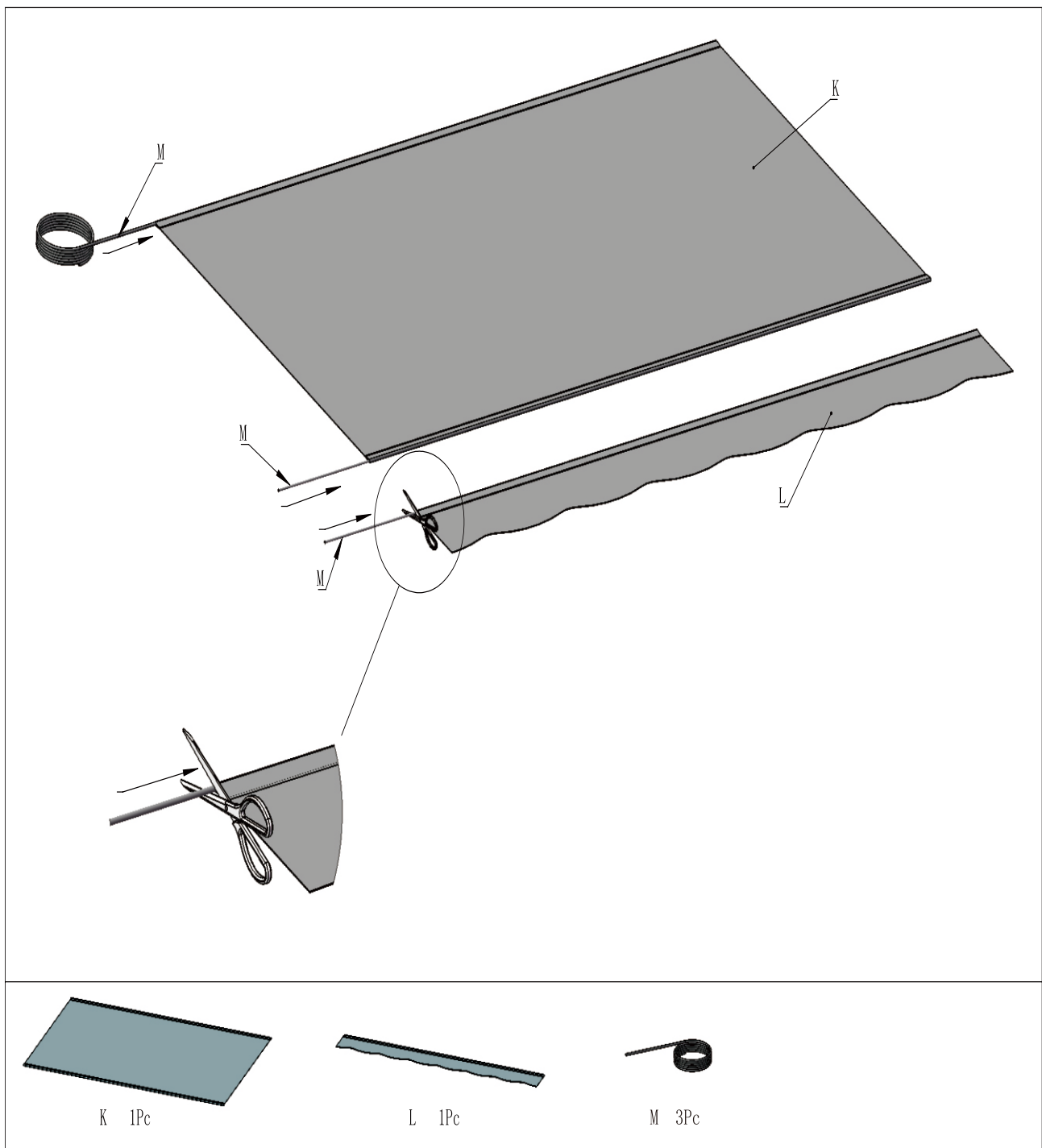

**AVVERTENZA  
CAUSERÀ LESIONI!  
TAGLIARE SOLO DOPO AVER ASSEMBLATO  
COMPLETAMENTE**

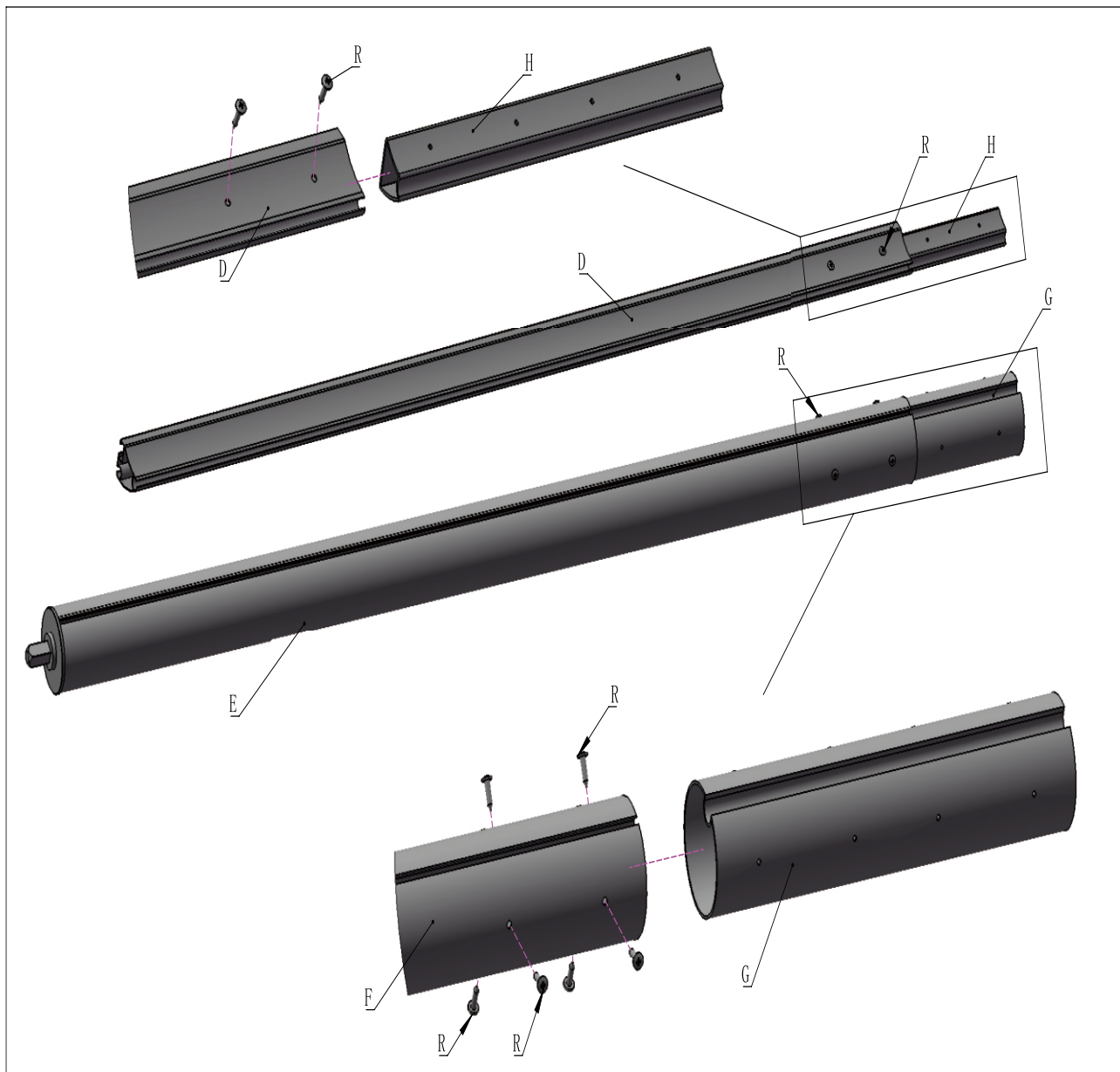
## PASSO 1: Infilare il tessuto e tagliarlo alla lunghezza necessaria



PASSO 2: Collegare il rullo tubolare e la barra anteriore (SINISTRA)



				
D 1Pc	H 1Pc	E 1Pc	G 1Pc	R 8Pcs

### PASSO 3: Montaggio del tessuto e collegamento del rullo e della barra anteriore

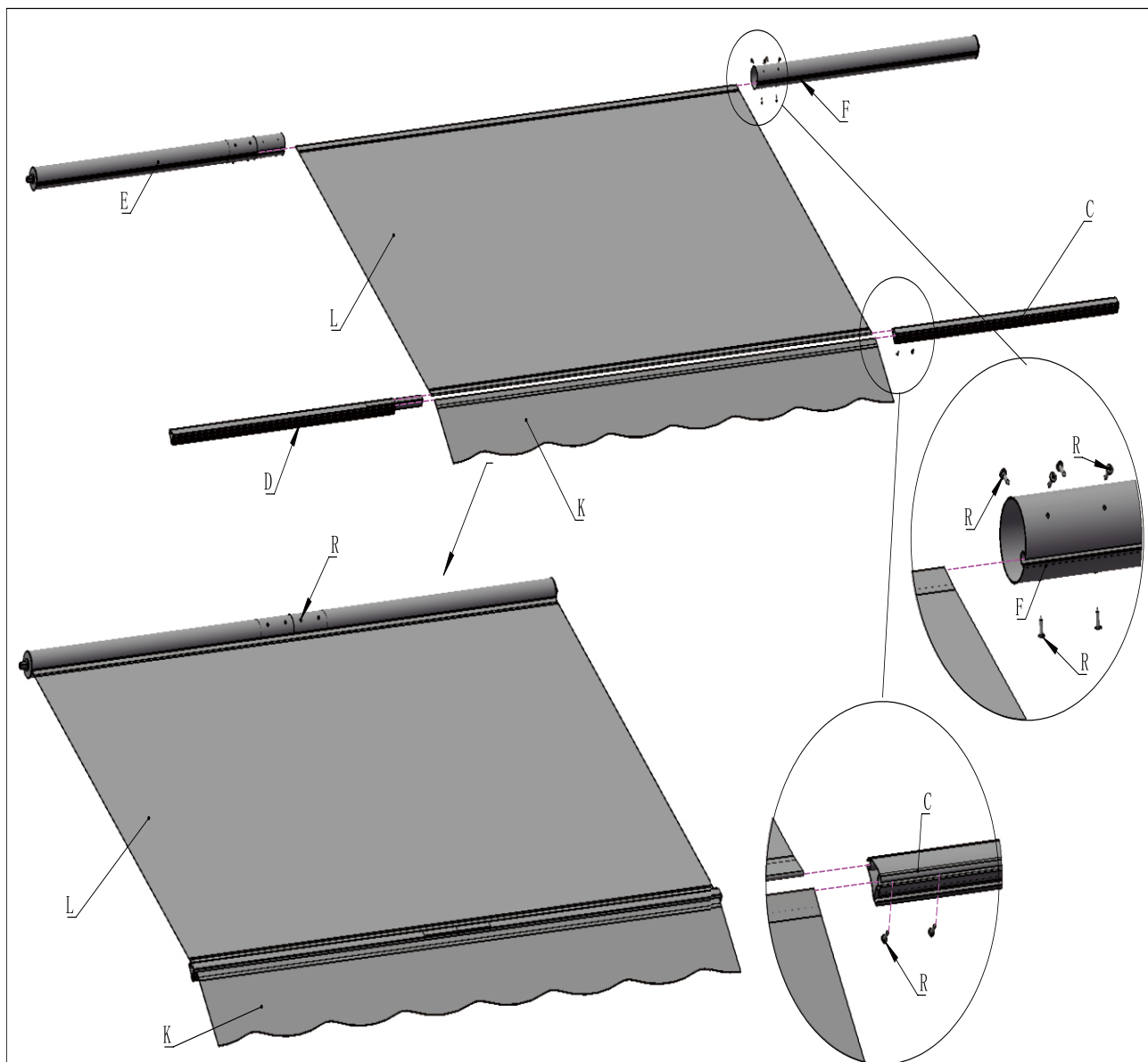

C 1Pc



F 1Pc



R 8Pcs

- PASSO 4:** 1. Inserire il tirante braccio-barra nella barra anteriore  
2. Inserire la parte P nella barra anteriore e bloccarla con la vite Q  
3. Inserire i tappi barra anteriore

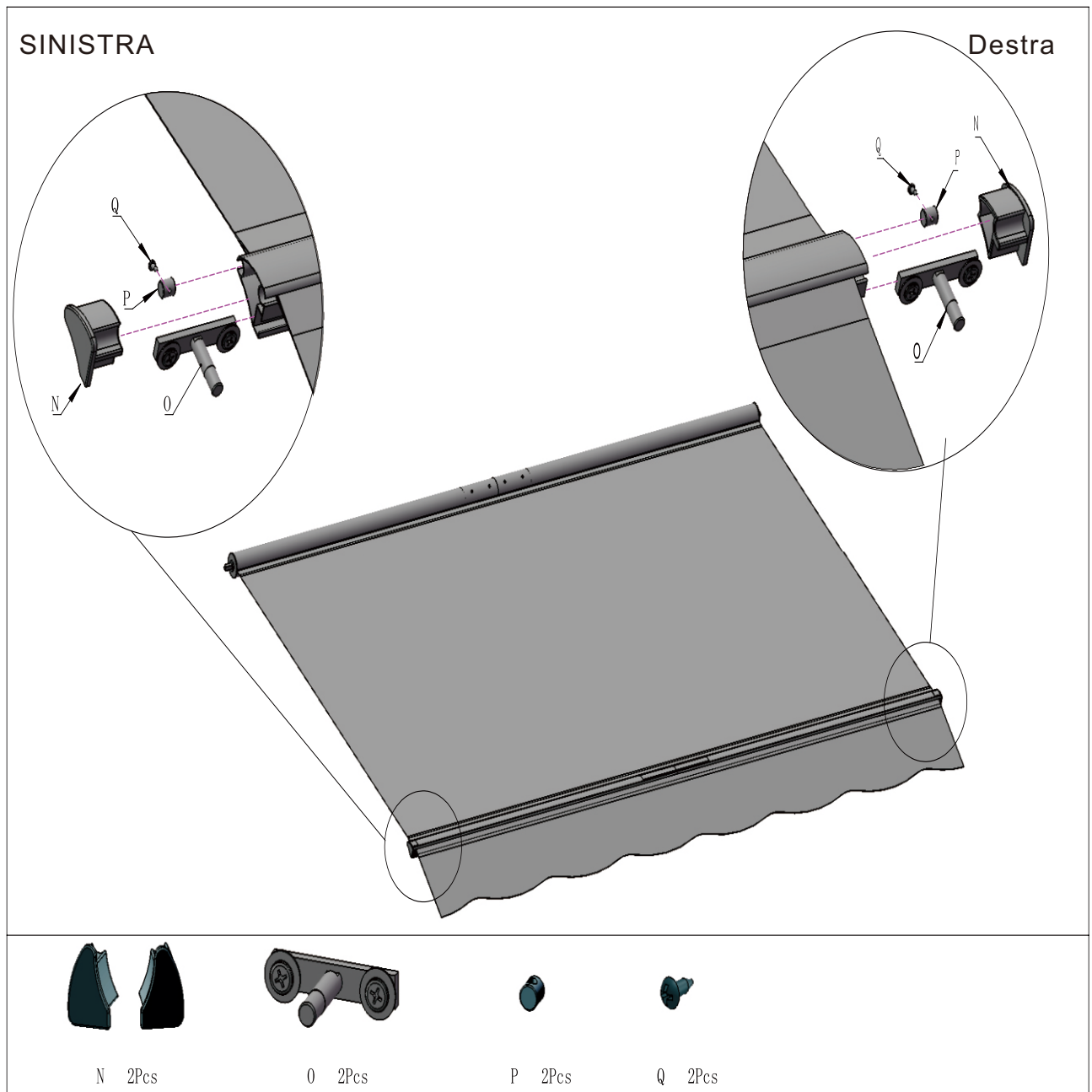

## PASSO 5: Arrotolare il tessuto della tenda il più stretto possibile

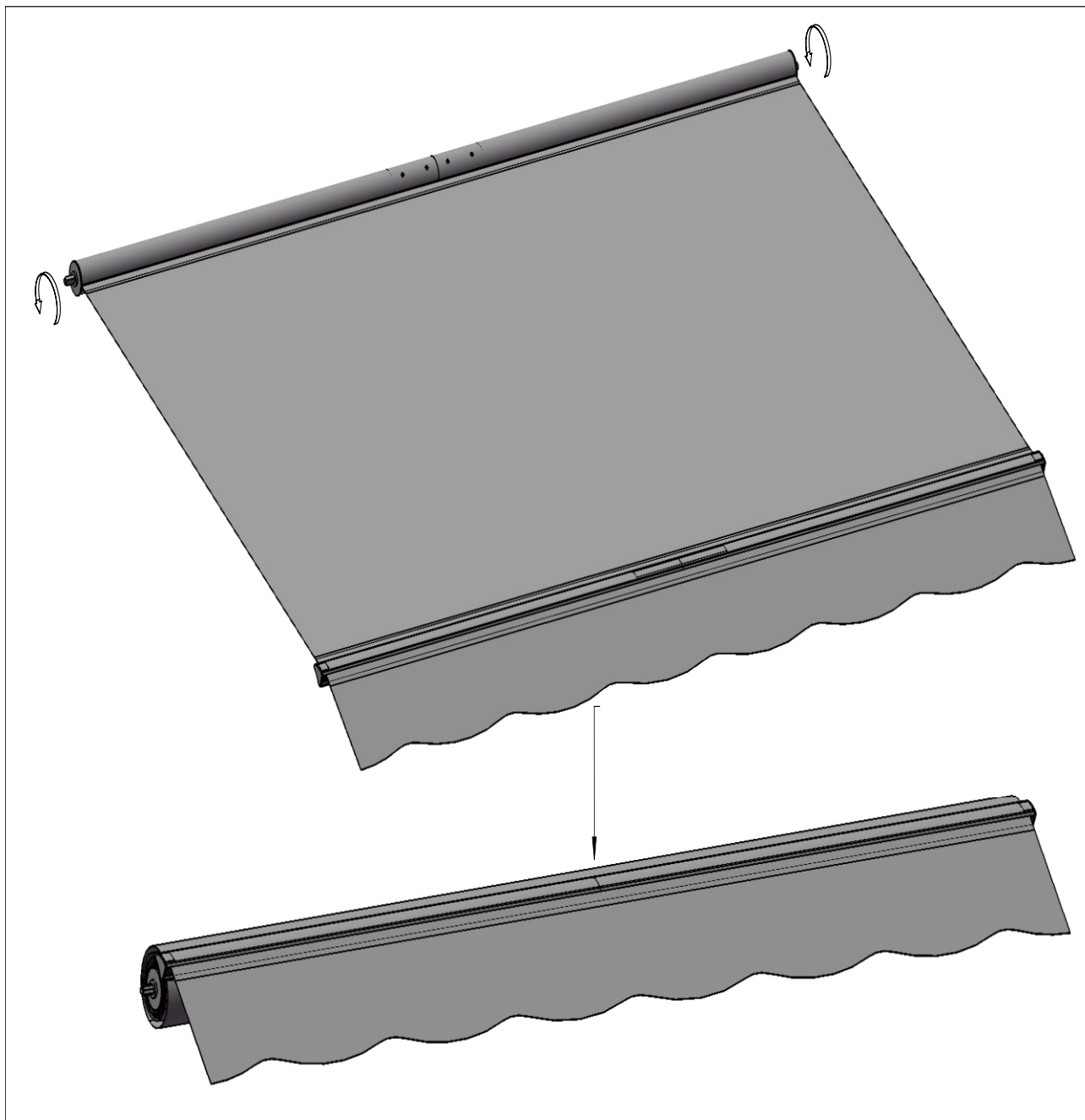

- PASSO 6: 1. Collegare la barra di torsione e avvitarla in seguito  
 2. Inserire il rullo nel foro quadrato della scatola ingranaggi e nel quadrato rotondo del supporto del rullo  
 3. Collegare le due barre di torsione e avvitarle

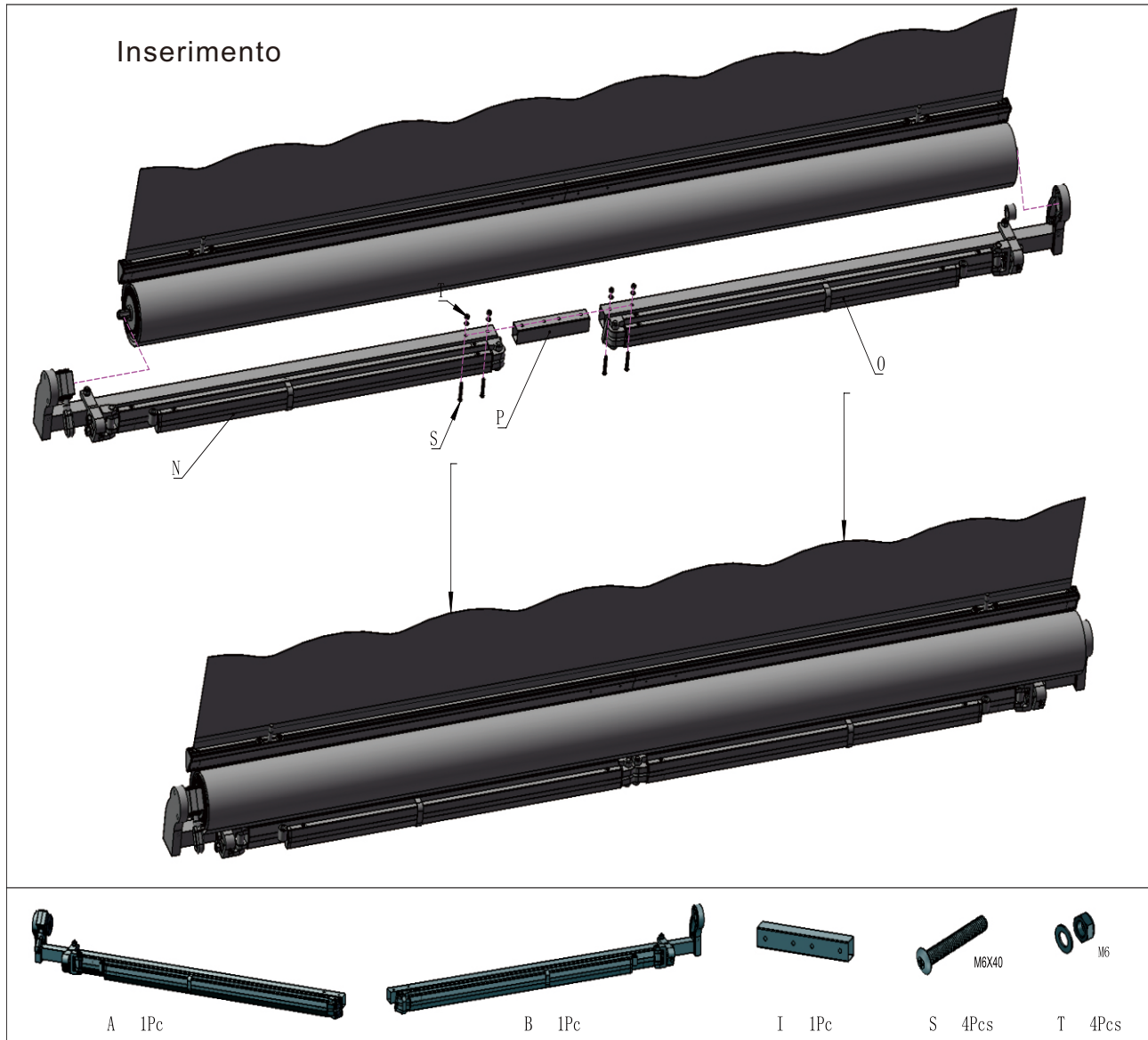

**PASSO 7: Impostazione della posizione della tenda**

1. Spostare il collegamento del braccio fino a quando il supporto del braccio della barra anteriore non è collegato attraverso di esso.
2. Allineare la barra anteriore e il braccio e serrare la vite O
3. Quindi serrare il bullone regolabile U fino al 90%

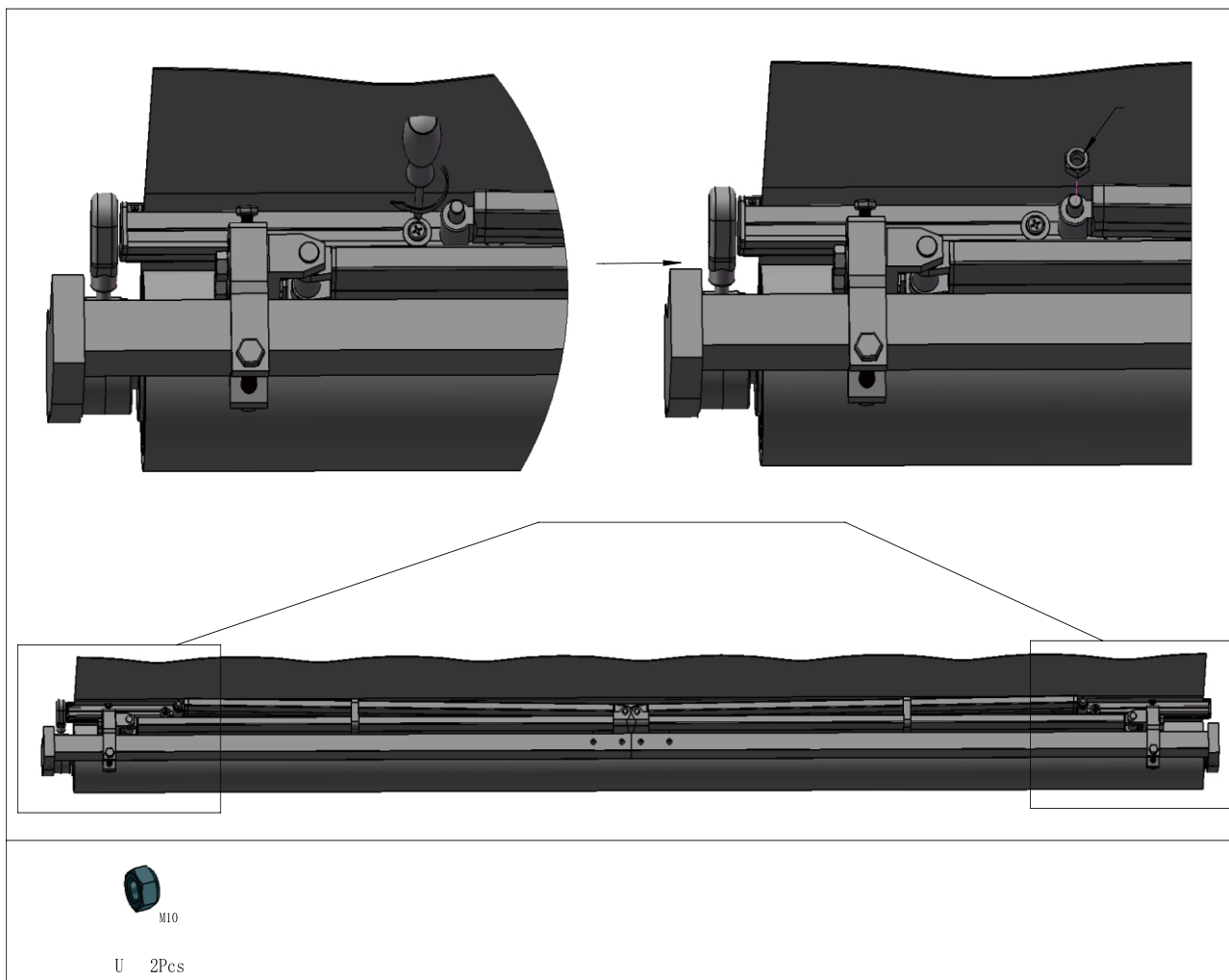

**PASSO 8: Finitura dell'assemblaggio della tenda**

1. È possibile tagliare le guaine di sicurezza che bloccano i bracci e la barra di torsione. Il montaggio della tenda è completo.
2. A questo punto, passare alla sezione per il montaggio a parete.

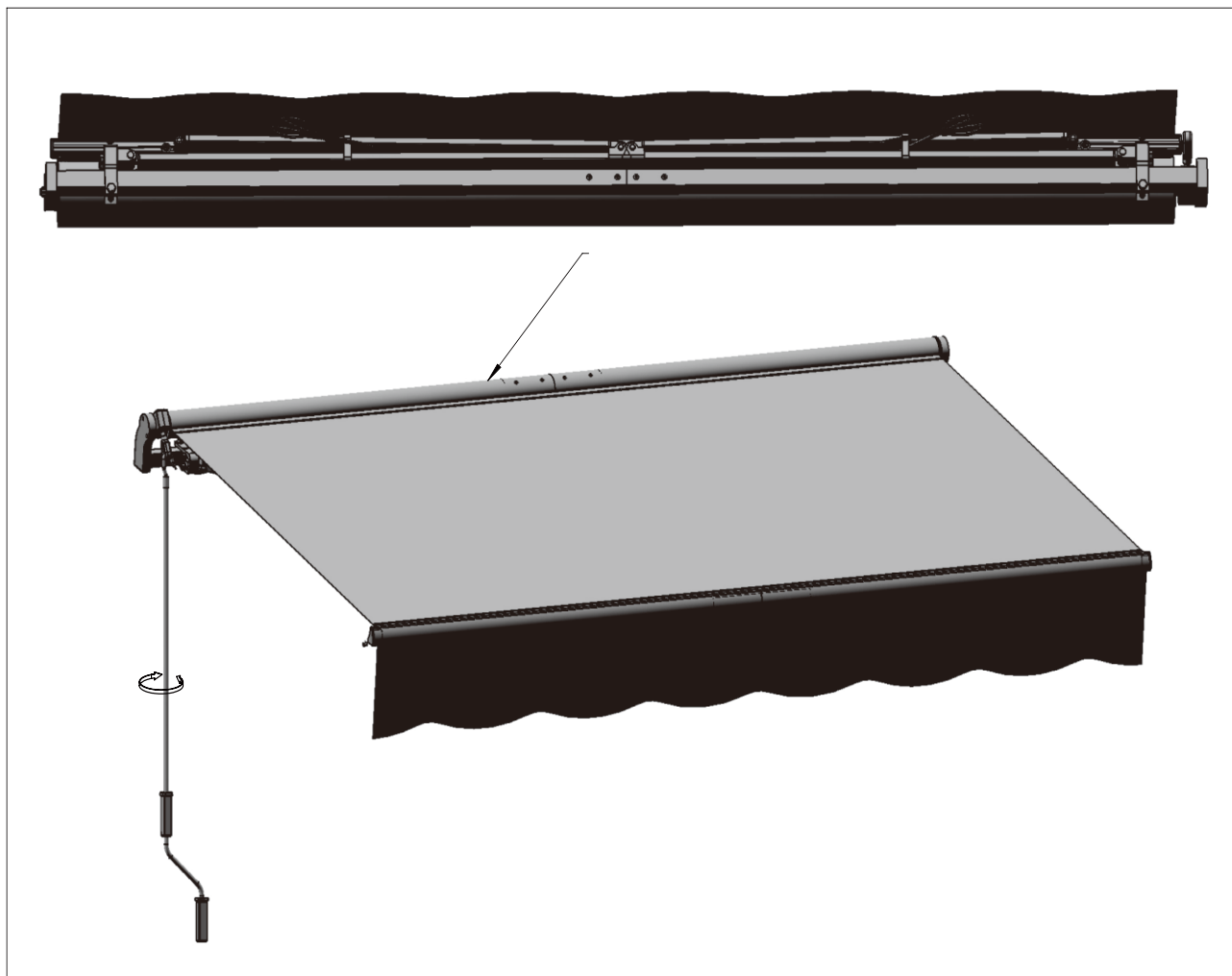

## 🔧 INSTALLAZIONE

### Note sul montaggio a parete

Questa tenda può essere fissata su cemento armato, mattoni e legno, tuttavia questo kit fornisce solo viti adatte per il montaggio su mattoni e pareti in cemento armato.

Se si desidera fissare la tenda su legno, utilizzare bulloni a testa tonda di lunghezza e diametro adeguati per fissaggio su travi di legno. La dimensione del bullone dipende dalla dimensione del supporto in legno; questi possono essere acquistati presso un negozio di ferramenta. Consigliamo di contattare un installatore professionista per un'installazione più sicura.

**Non tentare mai di fissare le staffe a parete a muri in pietra o ad altre superfici che non siano assolutamente solide!**



**ATTENZIONE:** la corretta posizione delle staffe è l'aspetto più importante dell'installazione della tenda da sole. È fondamentale fissare tutte le staffe di montaggio a borchie, travetti, testate o altri componenti strutturali importanti.



**AVVERTENZA:** Il mancato fissaggio sicuro di tutte le staffe alla parete potrebbe causare il crollo della tenda e causare lesioni personali.

### Altezza di montaggio

È importante prendere in considerazione l'area di apertura della tenda prima di imbullonare i supporti a parete. Se ad esempio si desidera montarla sopra una porta del patio, lasciare almeno 20 centimetri sopra il telaio della porta e assicurarsi che la tenda non interferisca con l'apertura e la chiusura della porta. L'angolo di inclinazione durante l'apertura può essere modificato solo in minima parte, quindi tenerlo in considerazione quando si decide dove posizionare la tenda.

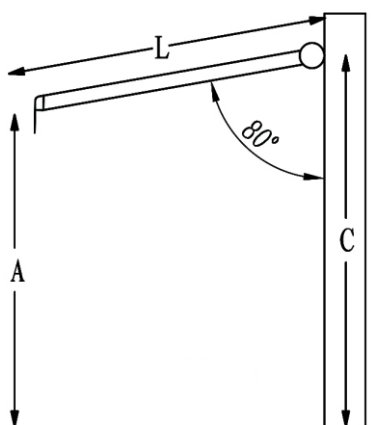

- **Altezza di installazione consigliata:** 20-30 centimetri.
- **L'angolo di inclinazione ideale (quando completamente estesa) è già stato impostato in fabbrica,** quindi potrebbe non essere necessario modificarlo.
- **La tenda da sole ha un'inclinazione di 60 centimetri verso il basso, o 15 gradi.**

#### CALCOLI:

È possibile utilizzare la seguente formula per calcolare l'angolo appropriato.

$$C = A + 0,17 * L$$

A = altezza desiderata della barra anteriore

L = lunghezza del braccio teso

C = altezza delle staffe a parete

*Raccomandiamo che la superficie della tenda da sole abbia un angolo di circa 80 gradi rispetto alla parete quando è aperta.*

### PASSO 1: Misurazione del sito di montaggio

1. Misurare la lunghezza della tenda lungo la parete dove si intende installarla. Questa linea sarà il punto più alto della tenda da sole e si allineerà con la parte superiore delle staffe a parete. Usa una livella per tracciare una linea con il gesso su tutta la lunghezza.

**2. Importante: Controllare che la linea sia completamente a livello.**

3. Accertarsi che la linea sia centrata sulla porta del patio, sulla finestra o su altre strutture, se applicabile.

4. Ora che si dispone di una linea retta e centrata, misurare il punto centrale e contrassegnarlo. In questo punto verrà installata la staffa della parete centrale.

5. Prendere una staffa a parete e posizionarne la parte superiore, completamente orizzontale, sotto la linea, come mostrato nello schema seguente. Con un gesso o una matita, contrassegnare la posizione di tutte le staffe a parete e i relativi fori dei bulloni.

Tende da sole < 10,8 piedi	Richiede solo 2 staffe a parete in totale: Una per ogni estremità delle barre di torsione.
Tende da sole da 10,8 - 14 piedi	Richiede 3 staffe a parete in totale: Una per ogni estremità e una al centro.
Tende da sole da 14,5 - 20 piedi	Richiede 4 staffe a parete in totale: Una per ogni estremità e due al centro.

Staffa a parete livellata con la linea orizzontale

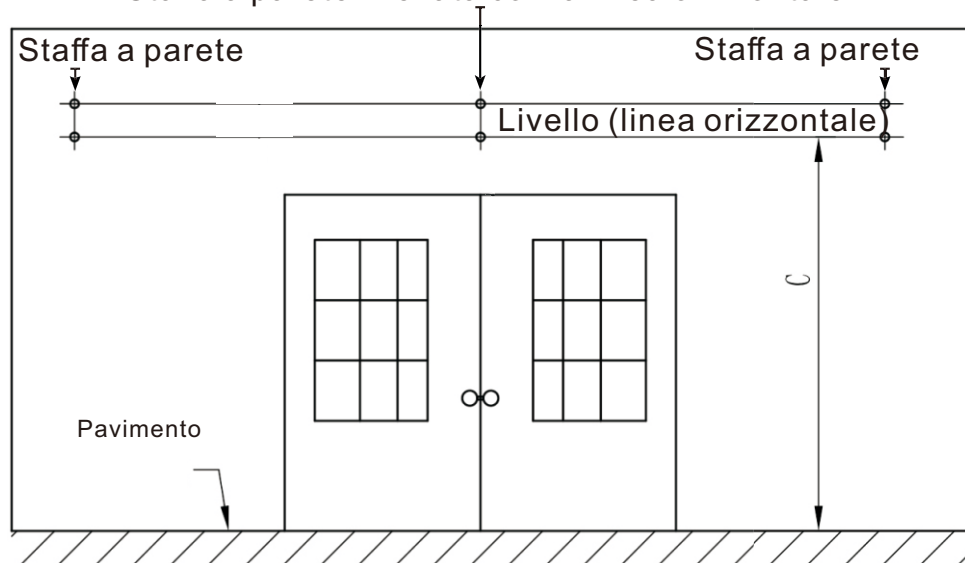

### PASSO 2: Praticare i fori dei bulloni

1. Ora che si dispone di una linea dritta e piana attraverso la parete con le posizioni delle staffe a parete e i relativi fori dei bulloni contrassegnati, è necessario praticare dei fori per montare le staffe.

2. Utilizzando una punta da trapano per muratura da 14 mm, praticare il primo foro del bullone di circa 4 pollici (9 centimetri) di profondità, come mostrato nello schema. I fori vanno praticati su mattoni pieni o calcestruzzo per offrire il supporto necessario per la tenda.

3. Praticare i fori rimanenti esattamente come indicato al punto 2.

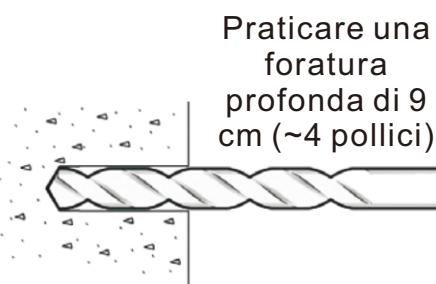

**!! IMPORTANTE:** Tutti i fori dei bulloni devono essere allineati verticalmente e orizzontalmente per garantire che la tenda sia dritta.

**Se non si è certi, ricontrollare l'allineamento prima della foratura. IMPORTANTE:** Il diametro e la profondità dei fori di montaggio

**!!** devono essere delle stesse dimensioni dei bulloni a espansione.

### PASSO 3: Preparazione per il montaggio

1. Dopo aver praticato tutti i fori, inserire i bulloni a espansione.
2. Potrebbe essere necessario inserire i bulloni con un martello di legno (o altro materiale non metallico).



*Se è necessario un martello per l'installazione, si consiglia di posizionare il dado sulla vite (allentato) prima di martellare per evitare di danneggiare le filettature dei bulloni.*

3. Assicurarsi che i bulloni siano saldamente in posizione, ma lasciarli fuoriuscire dalla parete di circa 1 pollice o meno, in modo tale che la staffa a parete possa essere installata su di essi.

4. Serrare saldamente i bulloni con una chiave esagonale da 19 mm. Si consiglia di utilizzare la chiave esagonale con un'estremità chiusa piuttosto che un'estremità aperta per evitare di danneggiare il dado, in caso di slittamento.

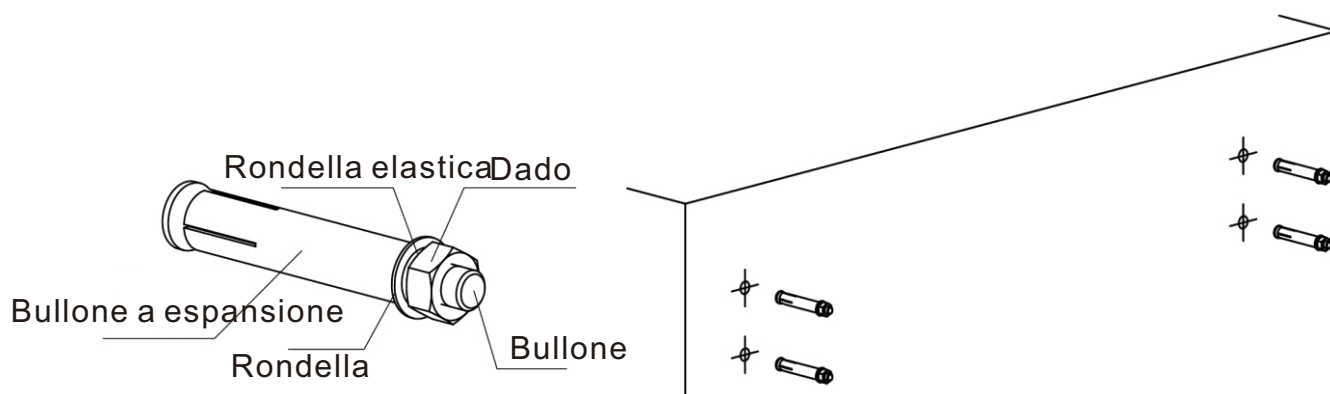

### PASSO 4: Montaggio delle staffe a parete

1. Ora che i bulloni sono saldamente nella parete, rimuovere i dadi che non sono posizionati saldamente sui bulloni.

2. Posizionare una staffa a parete su un set di bulloni. Questa dovrebbe essere facile da montare se i fori dei bulloni sono allineati correttamente.

3. Quando la staffa a parete poggia sui bulloni, posizionare una rondella sul bullone, quindi fissarla con un dado, come mostrato nello schema.

4. **Le staffe DEVONO essere posizionate saldamente sulla parete.** In caso di movimento, è necessario serrare maggiormente.

5. Ripetere questa operazione per ciascuna staffa a parete. Una volta fatto questo, tutte le staffe saranno saldamente in posizione.

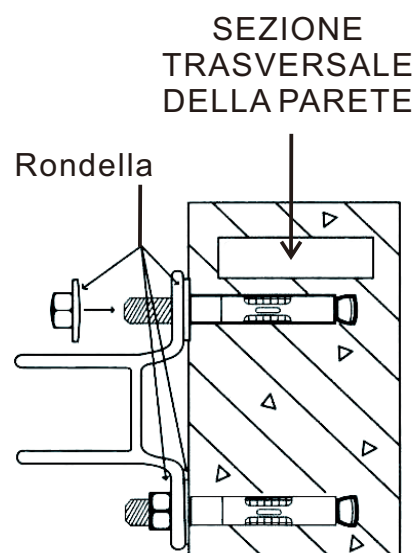

### PASSO 5: Montaggio della tenda

1. Ora che le staffe a parete sono fissate e in posizione, è il momento di installare la tenda sulle staffe.
2. Per montare la tenda sono necessarie almeno due scale o sedie robuste.
3. Posizionare i bulloni a espansione originali sulle staffe a parete e serrarli.
4. Infine, fissare tutti i bulloni a espansione.
5. Utilizzando la manovella manuale o un motorino (se applicabile), aprire completamente la tenda. La barra anteriore deve essere a livello.
6. **Congratulazioni! La tenda è installata. Una volta soddisfatti dell'altezza della barra anteriore (passo della tenda da sole), rilassatevi e godetevi la vostra tenda! In caso contrario, continuare a leggere.**

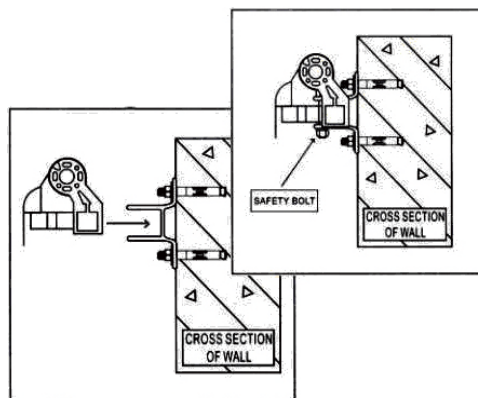

### ☺ INSTALLAZIONE OPZIONALE

#### REGOLAZIONE DEL PASSO/ANGOLO DELLA TENDA

Ogni tenda è dotata di un passo preimpostato (angolo) considerato ideale. Tuttavia, se è necessario effettuare una regolazione, è possibile farlo in pochi semplici passaggi.

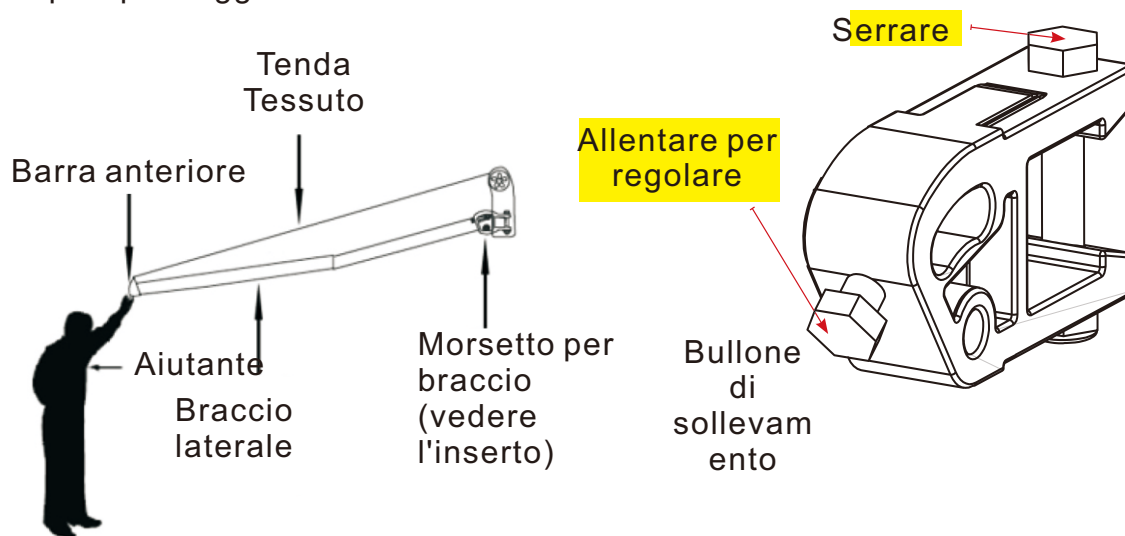

**!! IMPORTANTE:** L'innalzamento della barra anteriore ridurrà l'inclinazione (angolo) del tessuto, aumentando così il rischio di infiltrazione di acqua piovana nel tessuto. Per evitare che la tenda collassi a causa del peso dell'acqua piovana, è necessario ritrarla quando non è sorvegliata. Il mancato rispetto di questa precauzione potrebbe causare la rottura della tenda o lesioni personali.

Nota: Assicurarsi che la barra anteriore sia regolata in modo da essere perfettamente orizzontale. Qualsiasi disallineamento causerà una ritrazione non corretta.

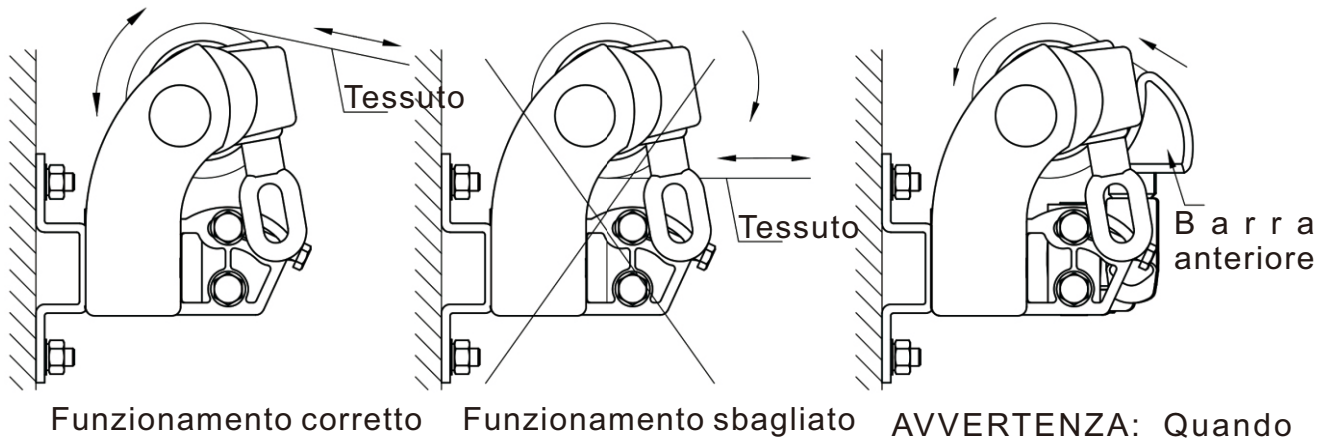
**Errori comuni**

Funzionamento corretto

Funzionamento sbagliato

**AVVERTENZA:** Quando la barra anteriore tocca il rullo come mostrato in figura, non cercare di avvicinarli, altrimenti il prodotto potrebbe danneggiarsi.

**US**

Imported by Aosom LLC  
 27150 SW Kinsman Rd Wilsonville, OR 97070 USA  
 MADE IN CHINA

**CA**

Imported by Aosom Canada Inc.  
 7270 Woodbine Avenue, Unit 307, Markham, Ontario Canada  
 L3R 4B9  
 MADE IN CHINA

Importé par Aosom Canada Inc.  
 7270 Woodbine Avenue, unité 307, Markham, Ontario Canada  
 L3R 4B9  
 Fabriqué en Chine

**UK**

IMPORTER ADDRESS:  
 MH STAR UK LTD  
 Unit 27, Perivale Park,  
 Horsenden lane South  
 Perivale, UB6 7RH  
 MADE IN CHINA

**FR**

ADRESSE D'IMPORTATION:  
 MH FRANCE  
 2 Rue Maurice Hartmann  
 92130 Issy Les Moulineaux  
 France  
 FABRIQUÉ EN CHINE



Adresses sur [quefairedemesdechets.fr](http://quefairedemesdechets.fr)

**ES**

IMPORTADOR:  
 SPANISH AOSOM, S.L.  
 C/ROC GROS, Nº15.08550, ELS HOSTALET DE BALENYÀ, SPAIN.  
 B66295775  
 WWW.AOSOM.ES  
 ATENCIONCLIENTE@AOSOM.ES  
 TEL: 931294512  
 HECHO EN CHINA

**PT**

SPANISH AOSOM, S.L  
 C.ROC GROS N.15, 08550. ELS HOSTALET DE BALENYÀ  
 TEL: 931294512 (SEG-SEX DAS 7:30H ÀS 16:30H)  
 INFO@AOSOM.PT  
 WWW.AOSOM.PT

**DE**

ADRESSE DES IMPORTEURS:  
 MH Handel GmbH  
 Wendenstraße 309  
 D-20537 Hamburg  
 Germany  
 IN CHINA HERGESTELLT

**IT**

IMPORTATO DA:  
 AOSOM Italy srl  
 Centro Direzionale Milanofiori  
 Strada 1 Palazzo F1  
 20057 Assago (MI)  
 P.I.: 08567220960  
 FATTO IN CINA