

Recommended Maximum Weight

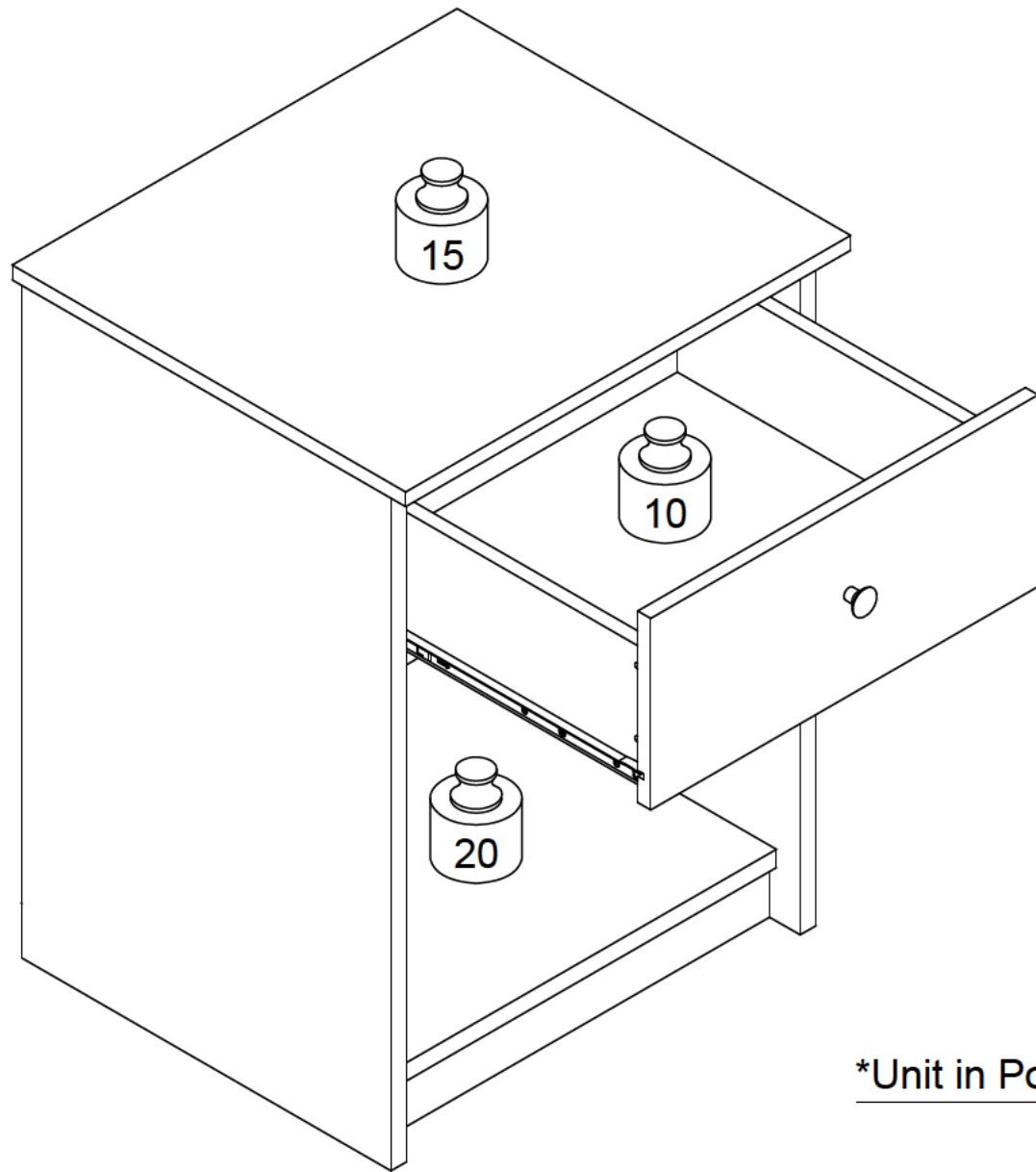

*Unit in Pound(lbs.)

WARNING:

>This unit has been designed to support the maximum loads shown. Exceeding these load limits could cause sagging, instability, product collapse, and/or serious injury.

>DO NOT allow children to climb on unit.

> Put heavier items on lower shelves.



Assembly Instruction

01:00

Approx. 1 Hour



Recomm. 1 Person

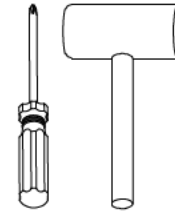

Tool Required

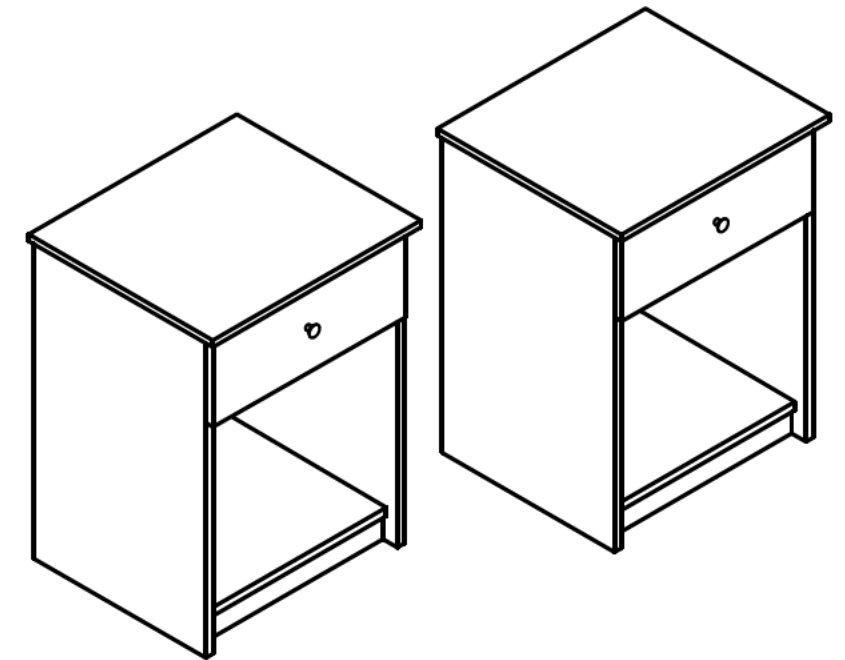

EXPLODED VIEW

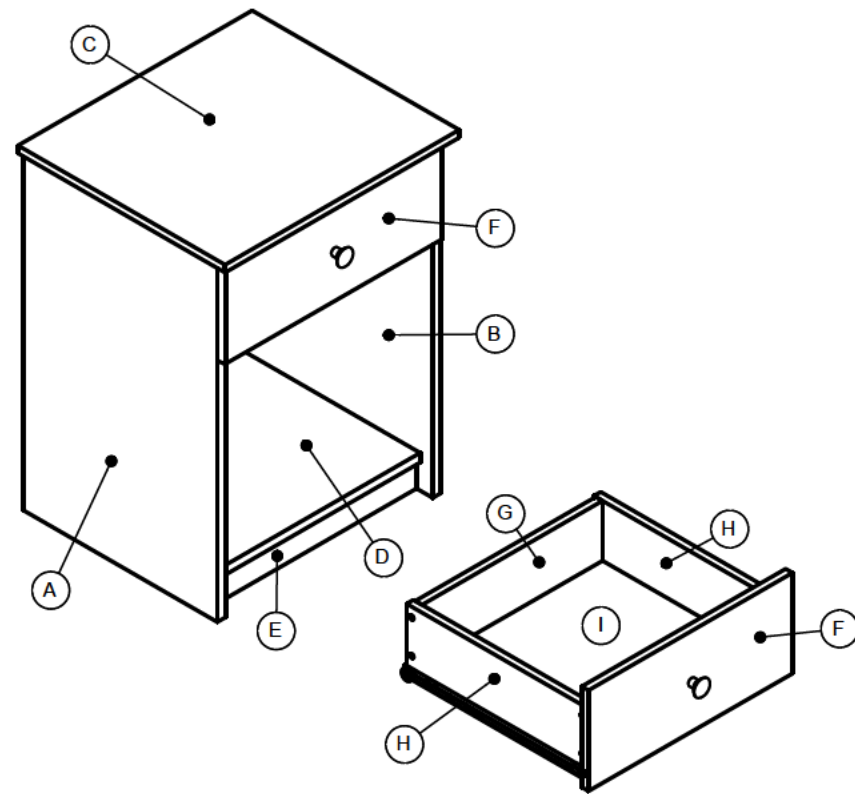

PARTS LIST

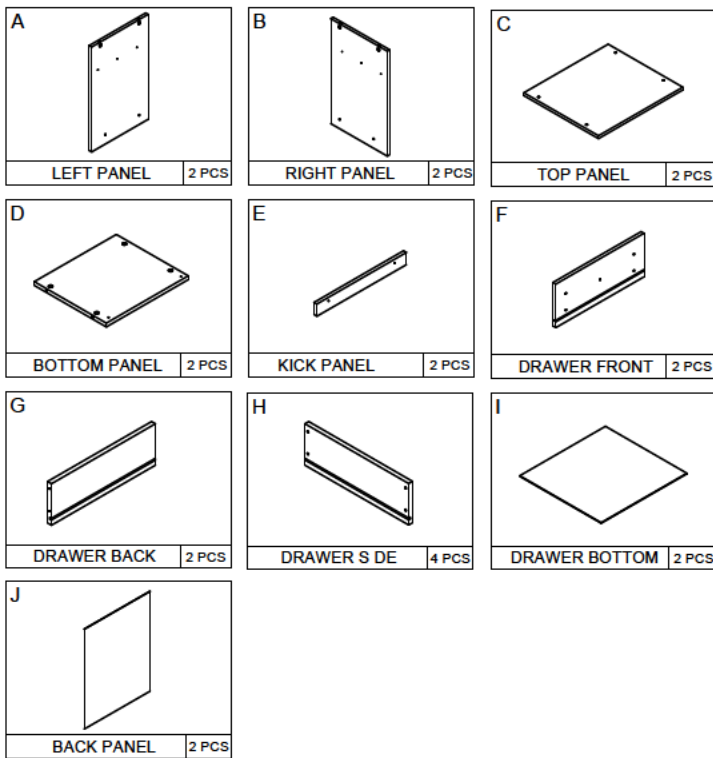

*All the part quantity are for two sets.

HARDWARE LIST

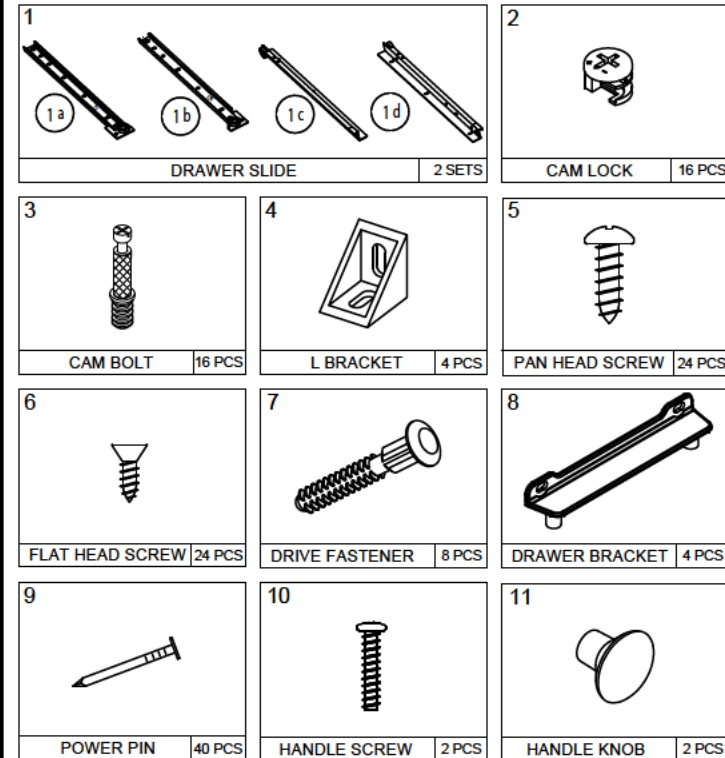

*All the hardware quantity are for two sets.

USEFUL HINTS BEFORE YOU START:

1. Read each step carefully before starting.
2. It is important that each step is performed in correct order to avoid difficulties.
3. Identify, soft and count the parts before assembly.
4. Assemble your furniture on packaging cardboard to prevent scratch or damage.
5. Clean the product with mild cleanser using soft damped cloth. Do not use harsh or abrasive cleanser.
6. Using incompatible hardware might cause damage to product.

STEP 9

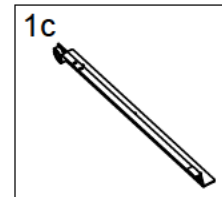

DRAWER SLIDE 1 PC

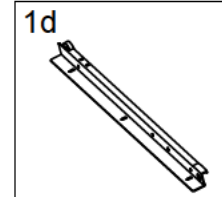

DRAWER SLIDE 1 PC

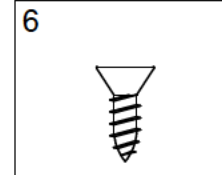

FLAT HEAD SCREW 6 PCS

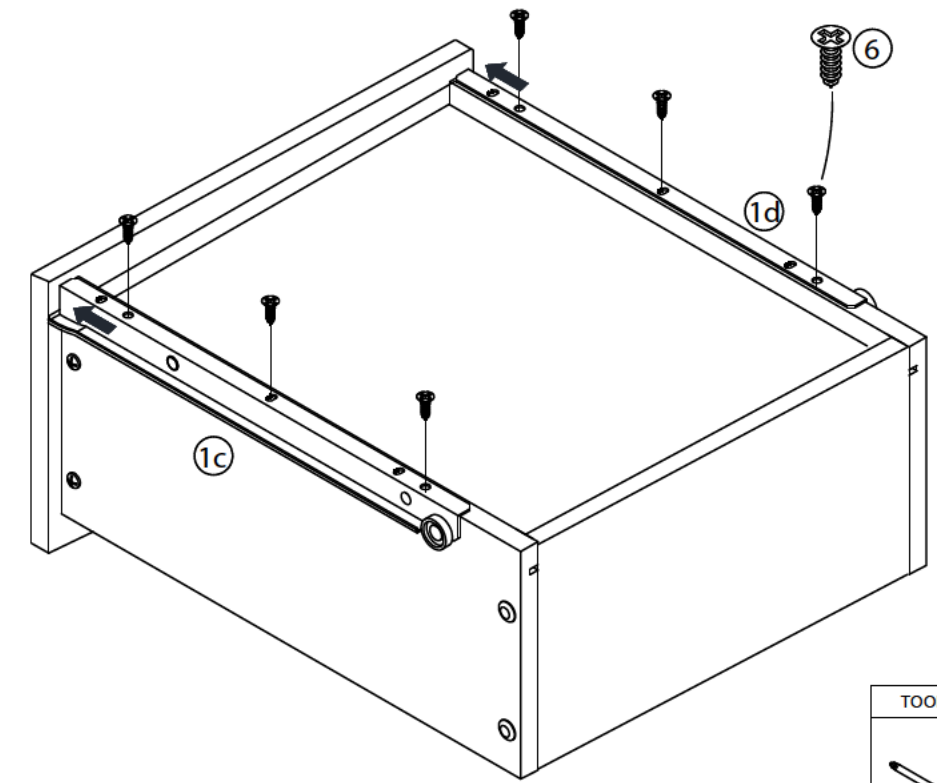

TOOL REQUIRED

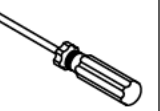

STEP 10

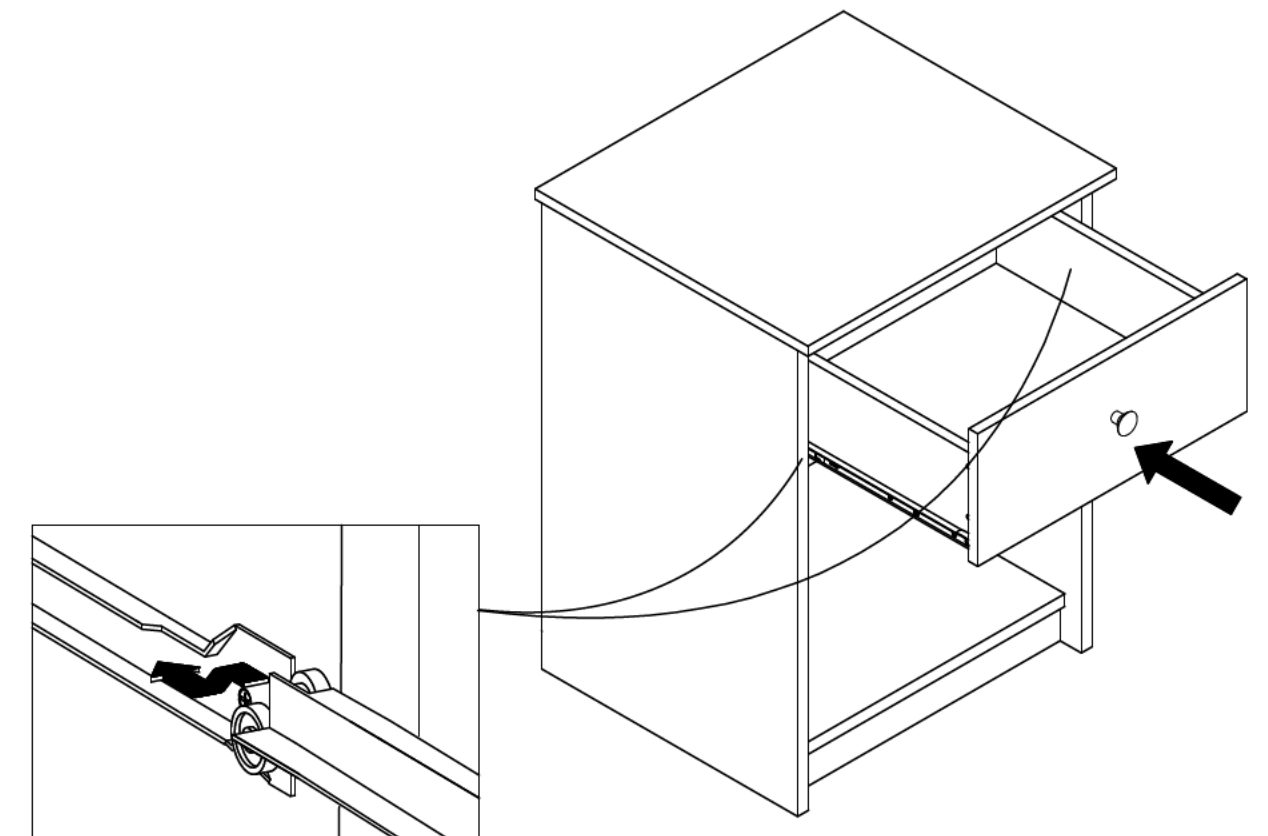

STEP 7

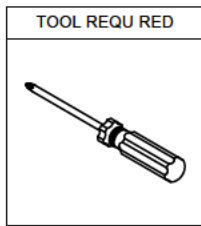
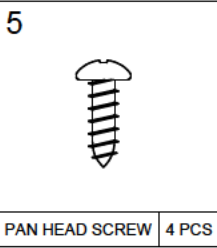
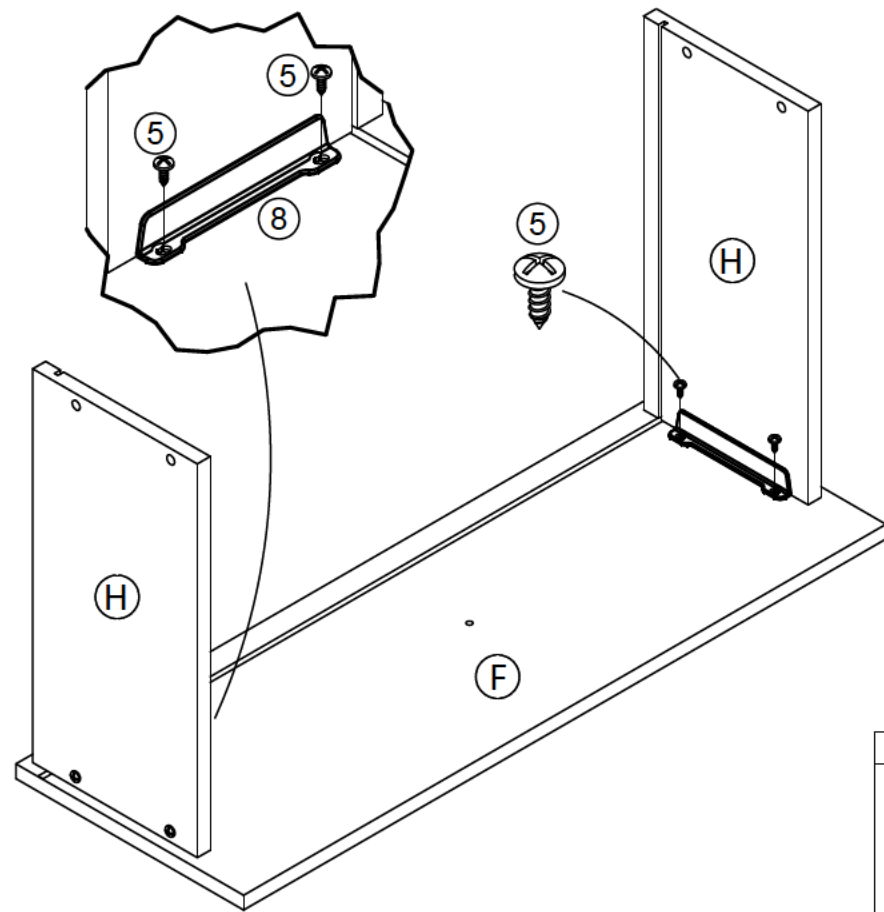

STEP 1

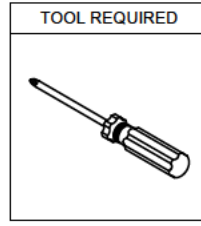
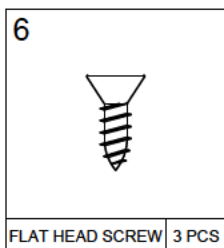
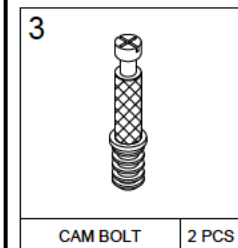
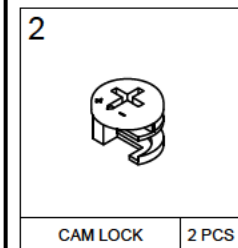
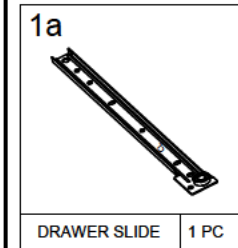
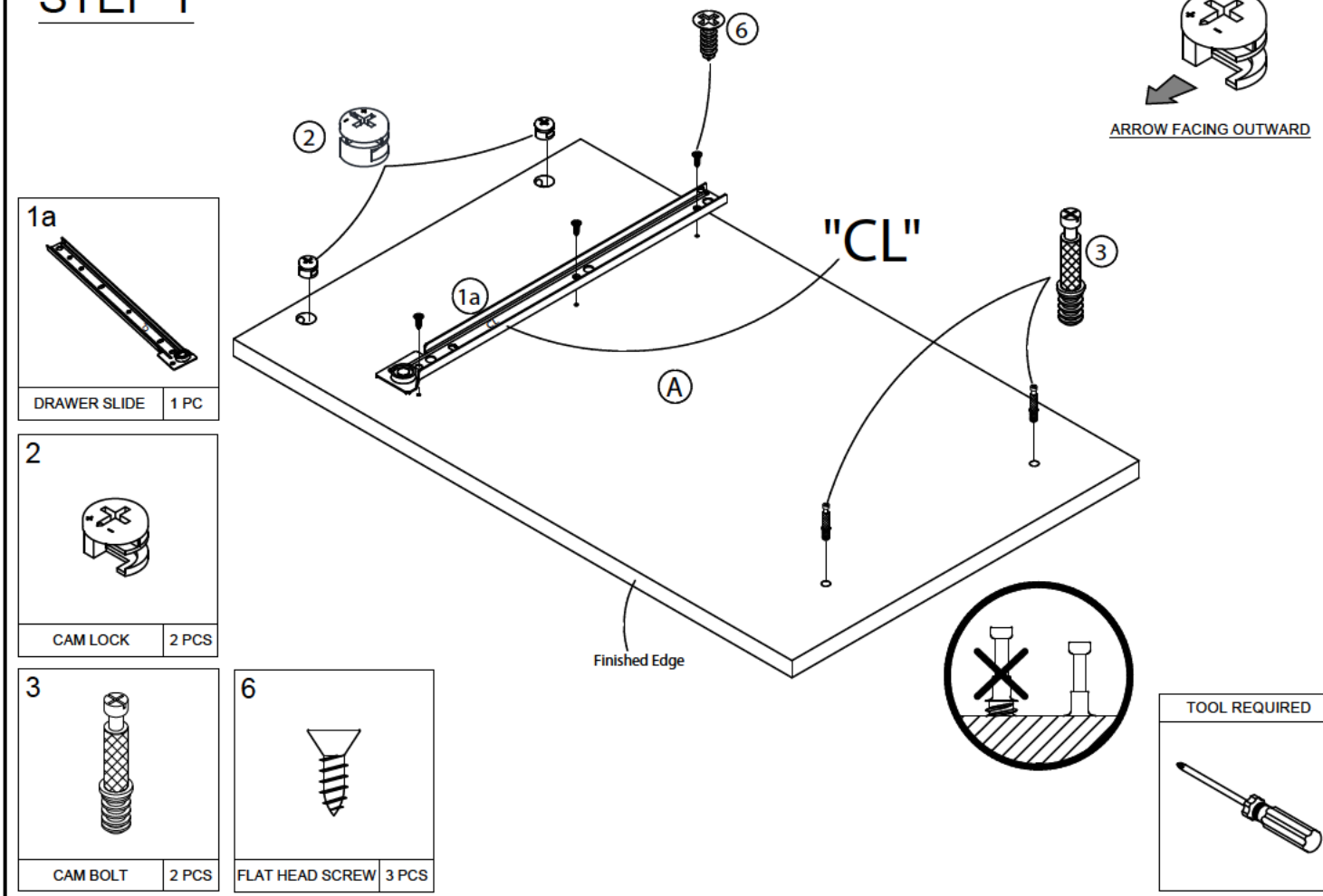

STEP 8

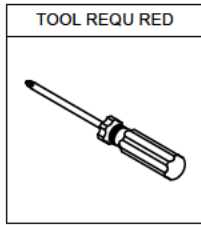
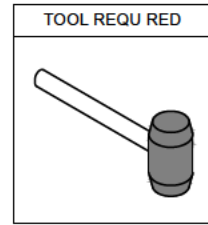
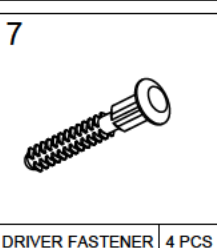
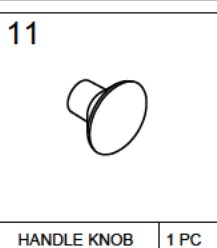
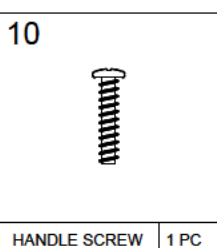
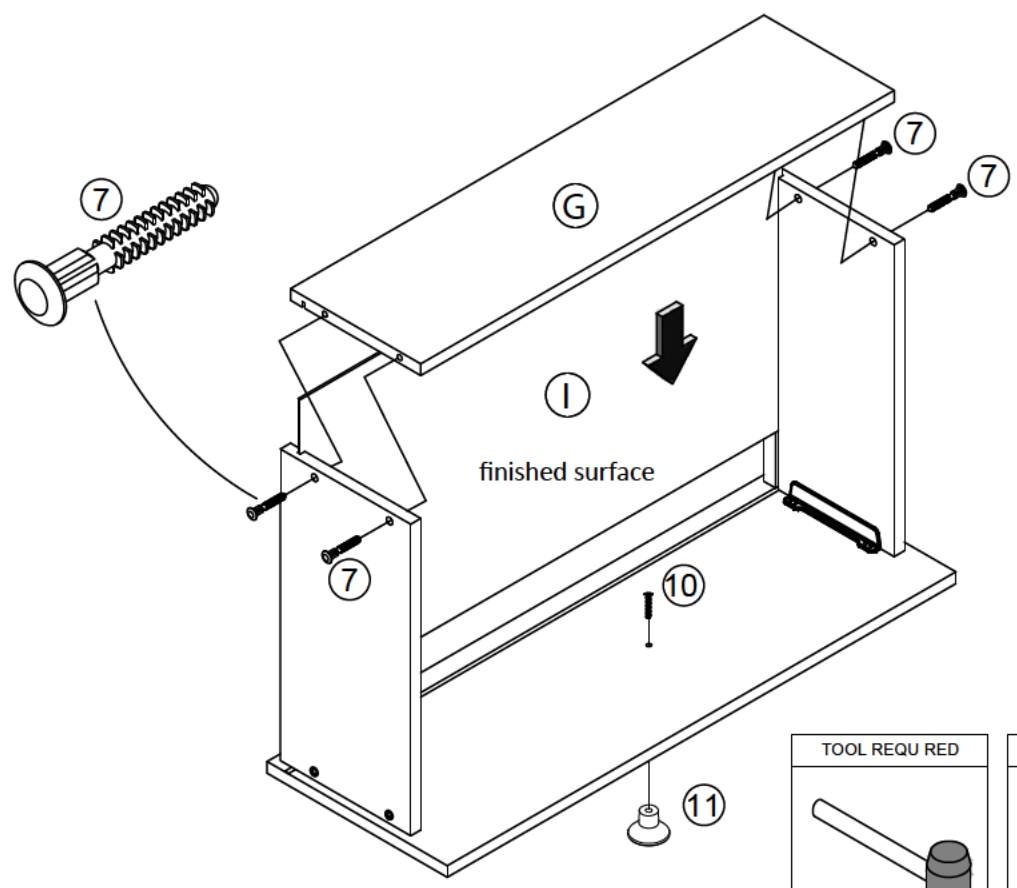

STEP 2

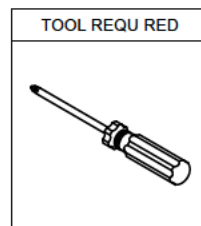
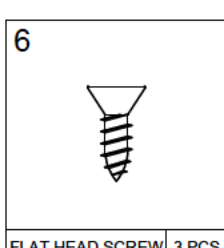
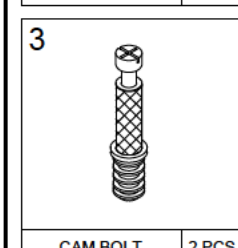
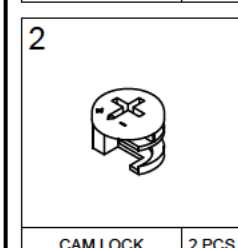
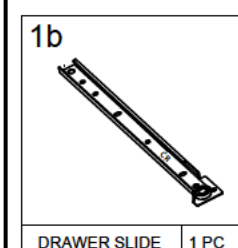
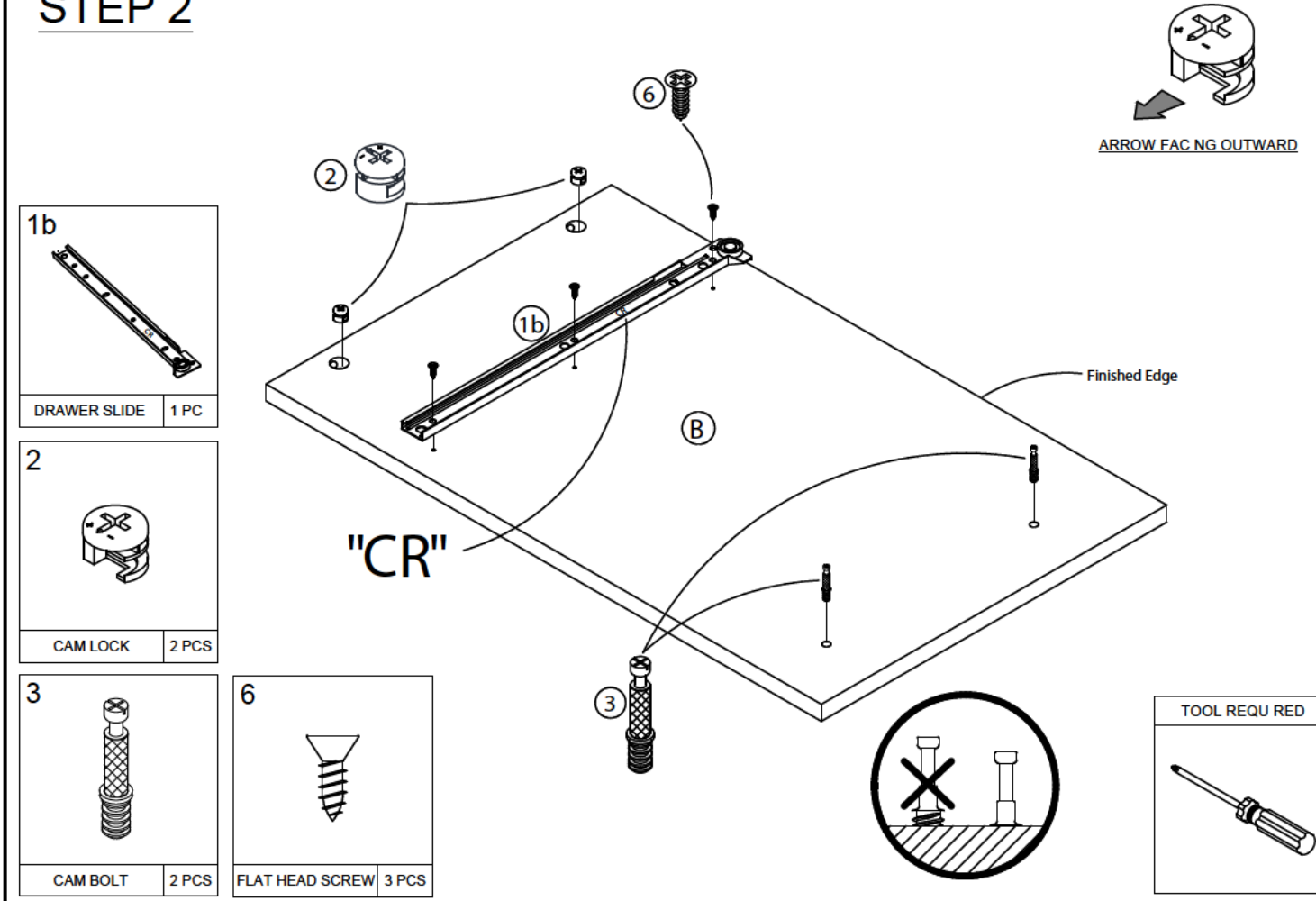

STEP 3

STEP 3.1

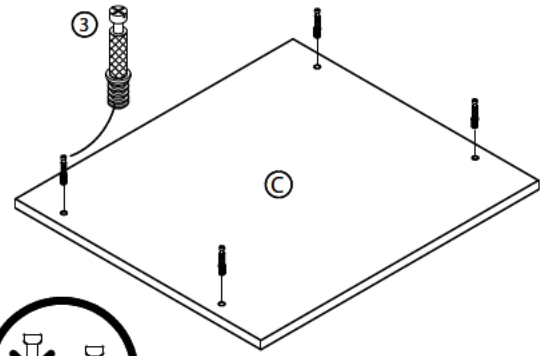

Finished Edge

STEP 3.2

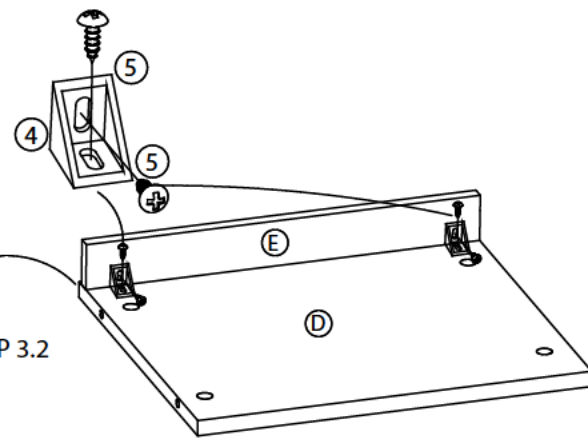

STEP 3.3

Finished Edge

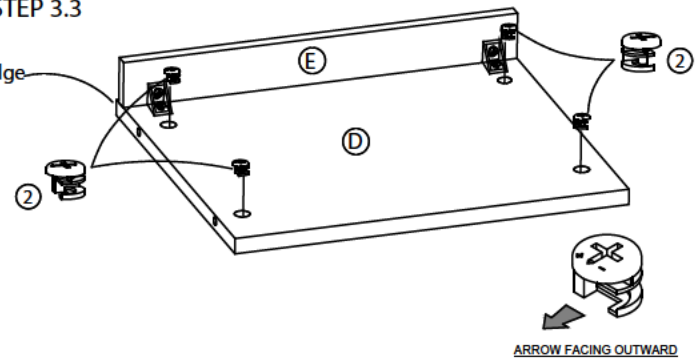

TOOL REQUIRED

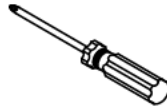

ARROW FACING OUTWARD

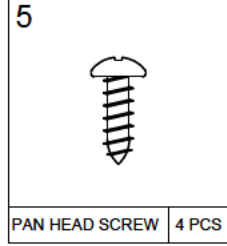
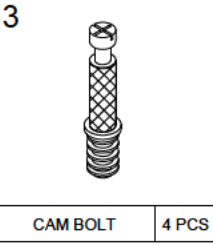
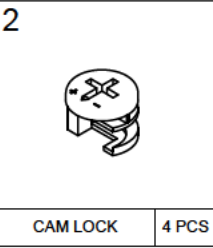
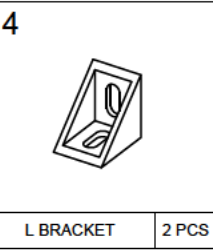

STEP 4

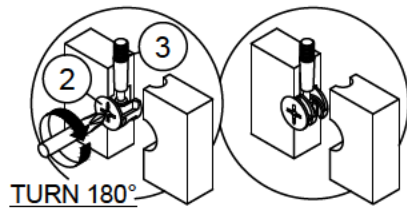

STEP 4.1

Finished Edge

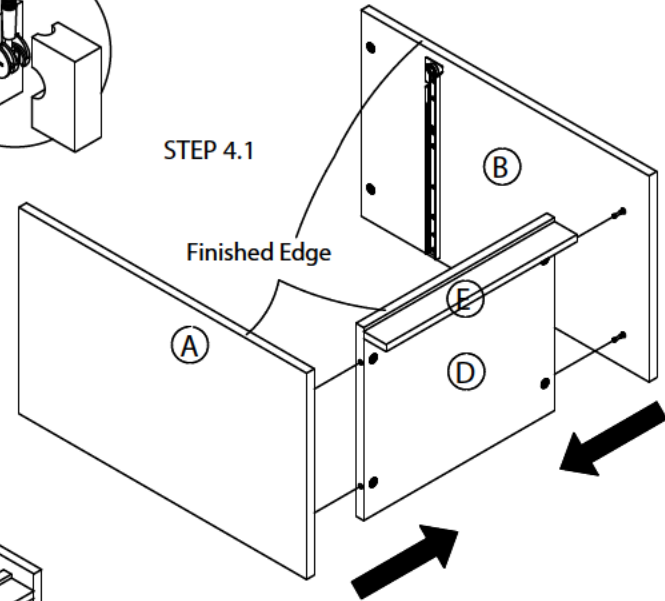

STEP 4.2

Finished Edge

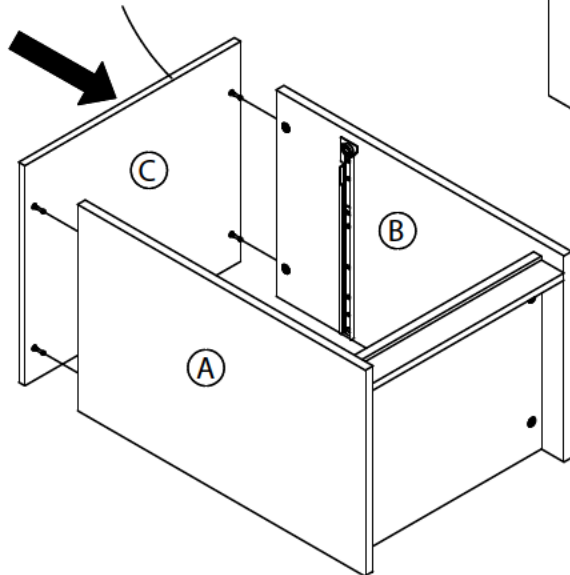

TOOL REQUIRED

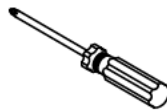

STEP 5

TURN 180°

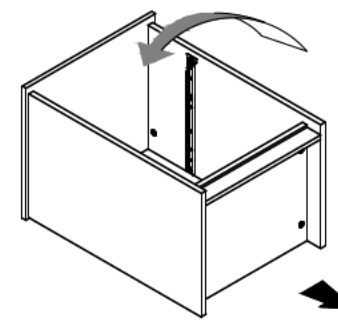

raw surface

J

Finished Edge

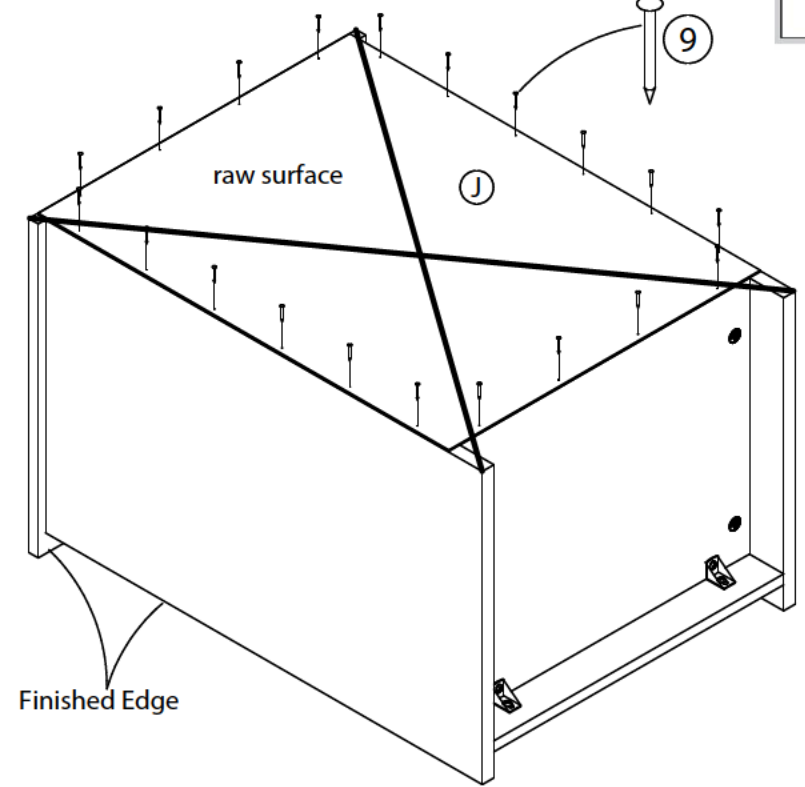

WARNING

WATCH YOUR HANDS AND FINGERS

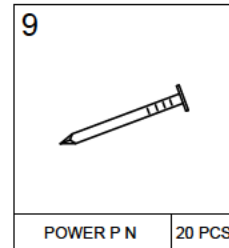

TOOL REQUIRED

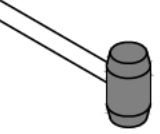

STEP 6

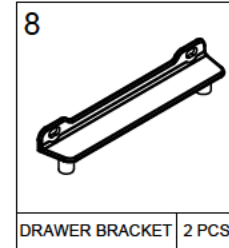
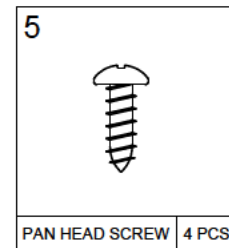
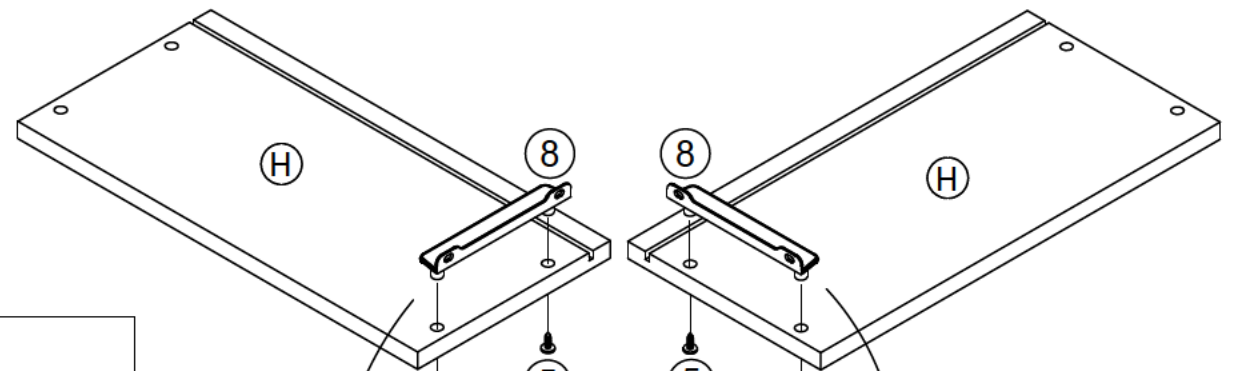

SIDE VIEW

SIDE VIEW

TOOL REQUIRED

