

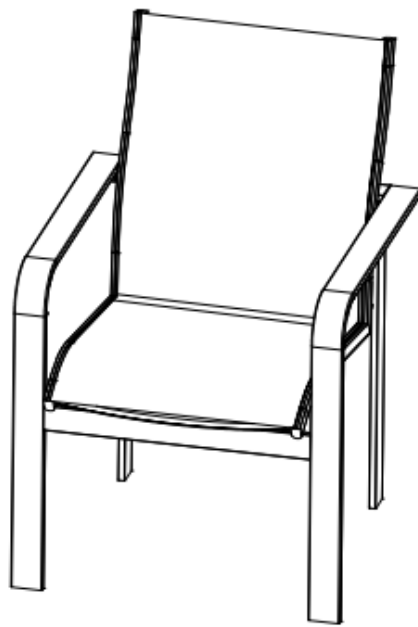

## Hollywood Sling Dining Chair



Item #.: 3403S01AR / 3403S01PL

Customer Service

[service.iloutdoor@gmail.com](mailto:service.iloutdoor@gmail.com)





Monday - Friday, 9:00a.m.– 5:00p.m. CST

Toll Free: 1-877-469-0017 Fax: (832)-201-9138

# WARNING

Please read instructions carefully and thoroughly before assembling. Check parts against the parts list to make sure you have all the parts needed for proper assembly. Familiarize yourself with the inventory of parts and the accompanying illustrations to ensure safe and proper assembly. **DO NOT ATTEMPT TO ASSEMBLE IF PARTS ARE MISSING OR DAMAGED. IMPROPER ASSEMBLY MAY RESULT IN DAMAGE OR SERIOUS INJURY.**

**Place the chair on a non-abrasive flat surface to prevent scratching.**

PART #.	DESCRIPTION	PICTURE	QTY
A	Chair Seat		4
B	Chair Base		4
C	Bolt with washers (M6 x 40)		24
D	Allen Wrench		1

1. Place the chair seat (A) upside down on a non-abrasive flat surface. Align the holes in chair base (B) with the holes in the chair seat (A), Loosely secure chair base (B) to the chair seat (A) with the bolt with washers (C). Do not tighten the bolts at this point.

2. Check the alignment of the chair base (B), and adjust if necessary. Once the alignment is correct and all bolts are in place, Properly tighten all the bolts (C) using allen wrench (D). Carefully turn the chair to the upright position.

**REPEAT ABOVE STEPS TO ASSEMBLE THE OTHER CHAIRS.**

Your chair is ready for enjoyment.

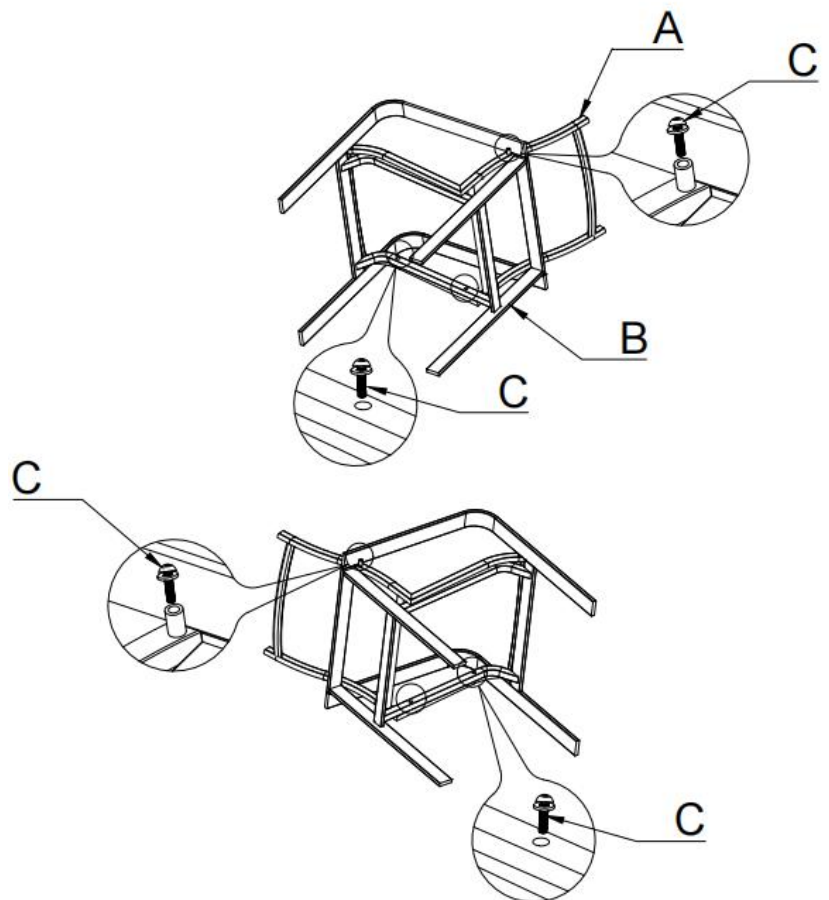

# CARE AND MAINTENANCE

Clean furniture frame with a wet towel using mild soap and water solution. Dry completely with a soft towel. Clean cushions and sling seat material with a mild solution of soap and water and hang cushions to drip dry completely. Store them in a clean dry area of your home. Do not machine wash or dry. Do not use bleach or strong solvents to clean any of your patio furniture as it will harm both fabrics and metal finishes. Caution should be used when using oils, lotions and other chemicals such as chlorine or repeated exposure to extreme weather conditions (including heat), which may cause permanent discoloration to the fabric. To maintain and protect the furniture, always cover it with an outdoor furniture cover or store in a safe area when not in use for long periods of time.

## Limited 1 Year Warranty

### General Residential Warranty

We warranty all our residential use furniture for 1 year. The warranty is valid from the date of purchase and applies only to the original purchaser. If your frame fails structurally during normal usage (other than damage as a result of dropping or breaking, a cast part other than a weld is not covered under this warranty) or if the finish peels, cracks or blisters within 1 year, we will repair, refinish or replace the frame at manufacturer's discretion (with same or similar product if discontinued) without charge. Due to the unique nature of hand-applied finishes the color of a replacement item (s) may not match exactly. Parts and labor are included.

### General Commercial Warranty

We warranty all our commercial use frames for 1 year from the date of purchase. Commercial use is defined as use in any public area. If your frame fails structurally during normal usage, (damage as a result of dropping or breaking a cast part other than a weld is not covered under this warranty) or if the finish peels, cracks or blisters within 1 year from the date of purchase, we will repair, refinish or replace the frame (with same or similar product if discontinued) without charge. Due to the unique nature of hand-applied finishes the color of a replacement item may not match exactly. Parts and labor are included.

### Frames

Frames are warranted to be free from defects in materials and workmanship for a period of 1 year (one (1) year for commercial use). Damage to frames or welds due to improper assembly or exposure to water and sub-freezing temperatures, is not covered. Breakage that is a result of product being dropped, acts of God, acts of war, etc. are not covered.

### Finish

The finish is warranted against peeling, cracking, or blistering for a period of one (1) year provided the product has not been scratched or abraded. Scratches and chips resulting from normal wear and tear are not covered. Fading resulting from exposure to elements is not covered. Stains as a result of chemical spills and certain food items are not covered.

### Fabric (if applicable)

Fabric and cushions are warranted for a period of one (1) year against seams separating or tearing. Fading or discoloration resulting from exposure to the elements, chemicals, or from spills is not covered. Fabrics are not warranted against mildew.

### Umbrellas & Umbrella Bases

The finish is warranted against peeling, cracking, or blistering for a period of one (1) year provided the product has not been scratched or abraded. Scratches and chips resulting from normal wear and tear are not covered. Fading resulting from exposure to elements is not covered. Stains as a result of chemical spills and certain food items are not covered. Rust is not covered.

### Straps and/or Wicker Weave (if applicable)

Straps and/or wicker weave are warranted for a period of one (1) year against separation or tearing. Fading or discoloration resulting from exposure to the elements, chemicals, or from spills is not covered.

### Freight

Shipping and handling charges are, at all times, the responsibility of the claimant. We do not ship outside of the North American continent.

### Warranty Exclusions

Failure caused by unreasonable or abusive use. Furniture that were clearance items, display models or items purchased in an "as is" condition, freight damage, furniture damaged by acts of nature, vandalism, fire, abuse, lack of proper care and maintenance, or improper assembly; straps and fabric against normal fading or discoloration from exposure to elements, oils, spills, fluids or chemicals; table top against breakage; hardware against corrosion or rusting; buckling or splitting of tubing resulting from exposure to water and freezing temperatures; glass table tops, purchased or replacement parts; plastics. Also excluded: loss of use of time and or inconvenience, money, travel, packaging or any other consequential or incidental damages. In no event shall Ideal Living's responsibility exceed the value of the replacement product. The warranty is to the original purchaser when items are purchased from one of our authorized retailers and is not transferable. All warranty claims must be submitted with a dated register receipt within the warranty period. Should replacement of the warranted item be unavailable, Ideal Living reserves the right to substitute items of our choice similar in style, color, and quality. For quality control purposes and verification, we reserve the right to request photographs of the damaged item(s). The terms of this warranty are subject to change without notice.

To obtain warranty service in the US, please contact Ideal Living's Customer Service Department at (877) 469-0017, between the hours of 9:00 am and 5:00 pm CST, Monday thru Friday or fax your request to (832) 201-9138 or email us at [Service.iloutdoor@gmail.com](mailto:Service.iloutdoor@gmail.com).