

SKU:SF001018WH

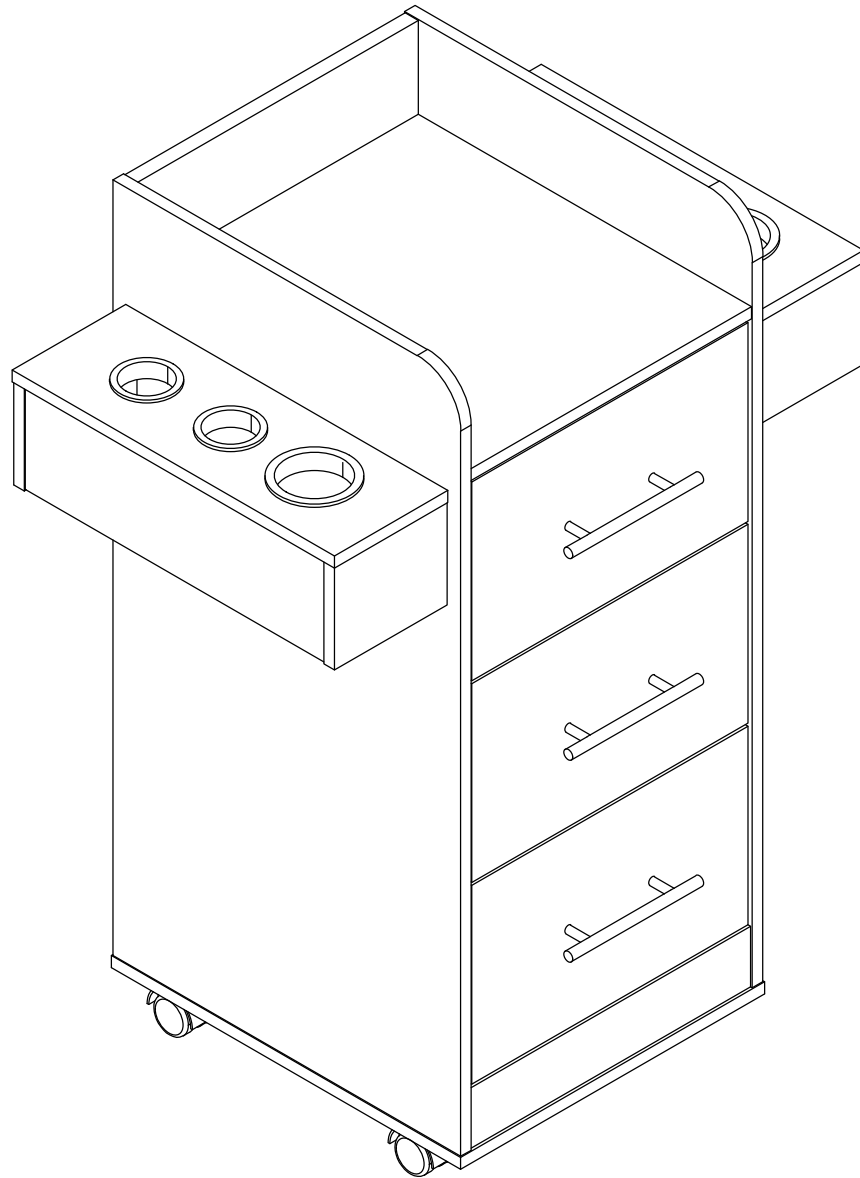

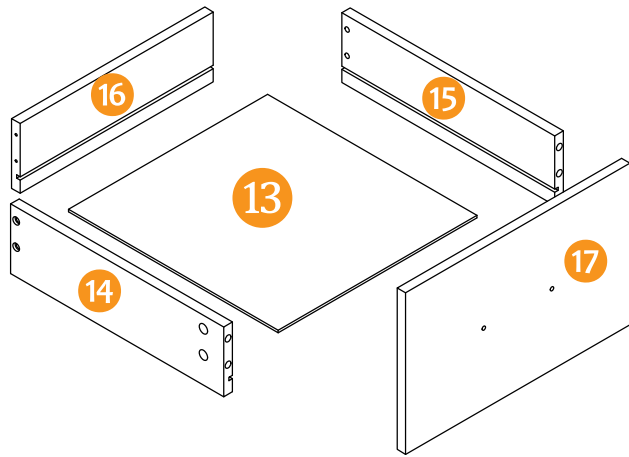
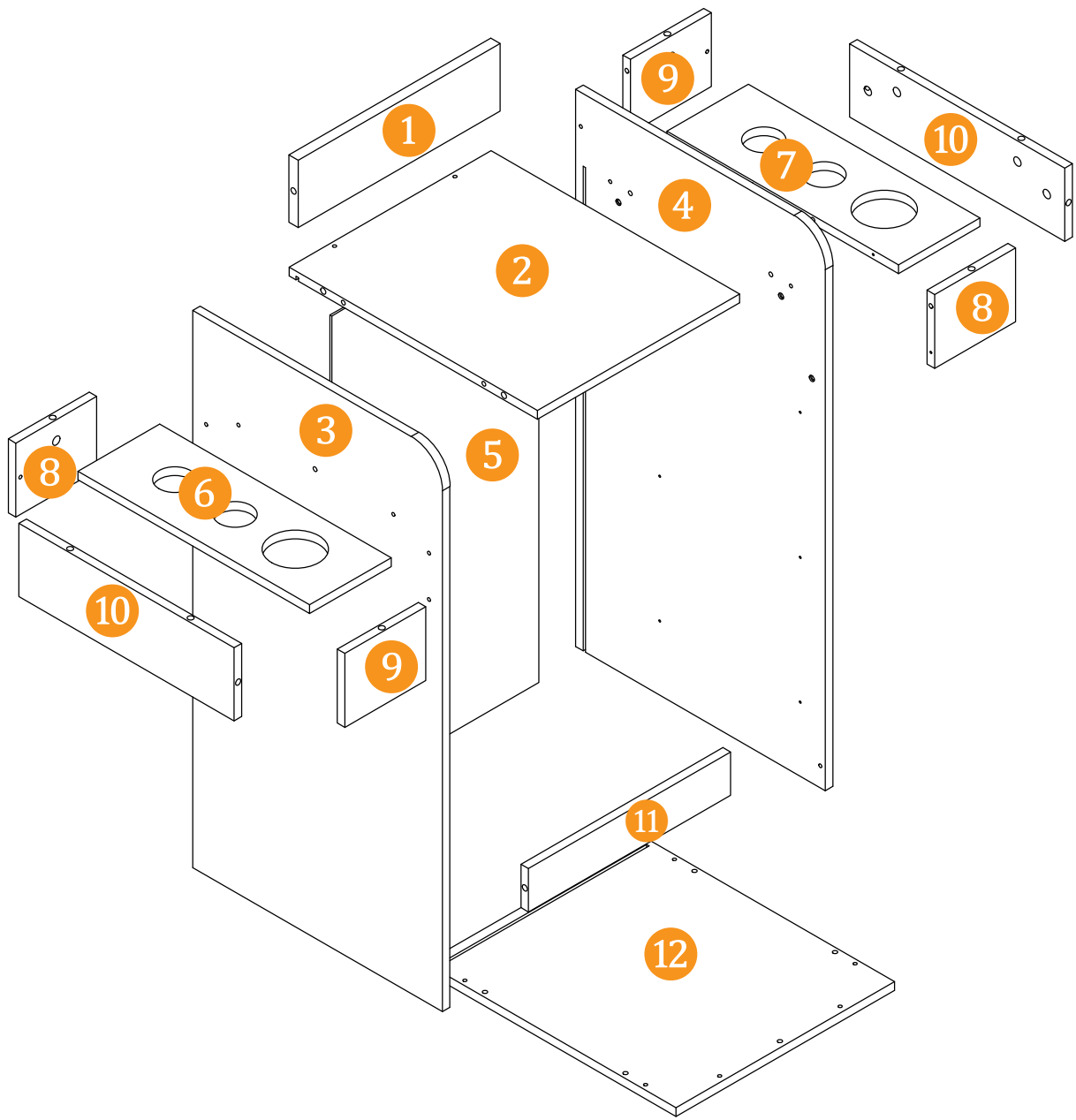

x3PCS

Before You Start

1. Read through each step carefully and follow the proper order
2. Separate and count all your parts and hardware
3. Give yourself enough room for the assembly process
4. Caution: If using a power drill or power screwdriver for screwing, please be aware to slow down and stop when screw is tight. Failure to do so may result in stripping the screw

Cam Lock Fastening System

This Cam Lock Fastening System will be used throughout the assembly process

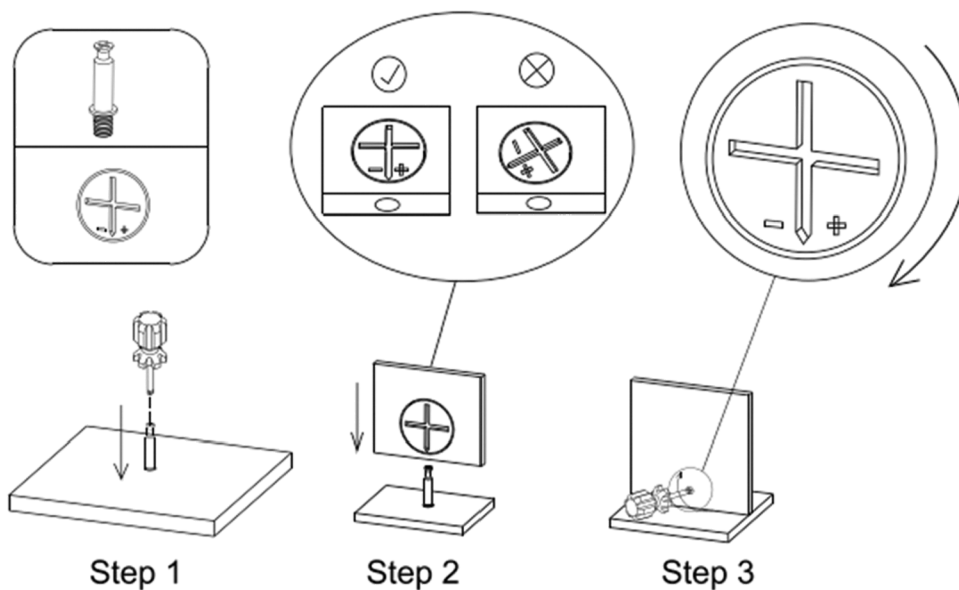

Parts List

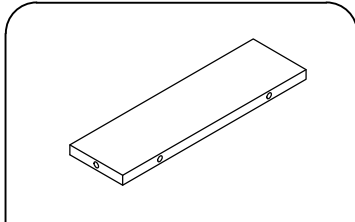

1

1PC

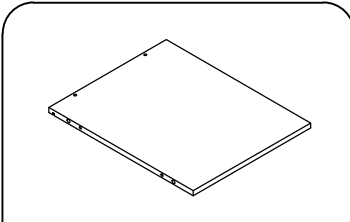

2

1PC

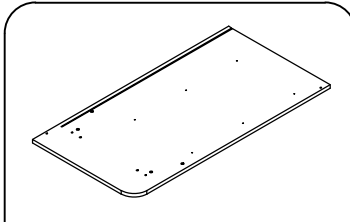

3

1PC

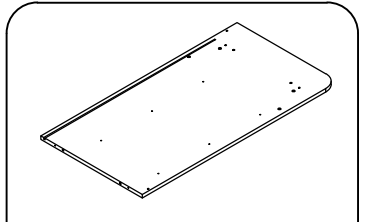

4

1PC

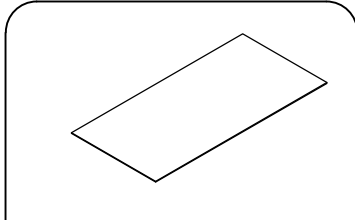

5

1PC

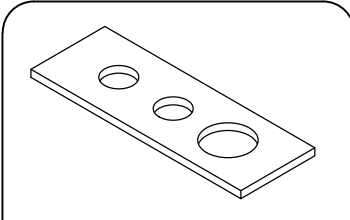

6

1PC

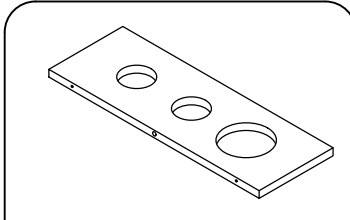

7

1PC

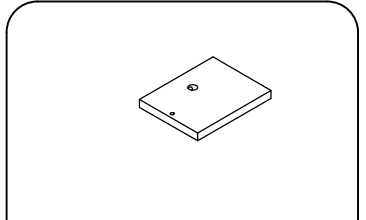

8

2PCS

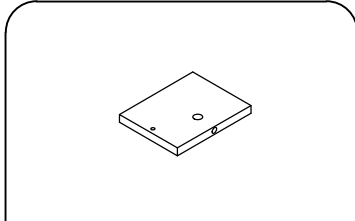

9

2PCS

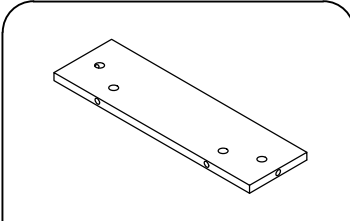

10

2PCS

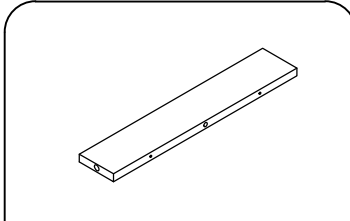

11

1PC

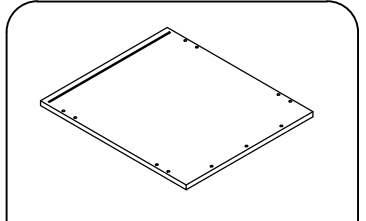

12

1PC

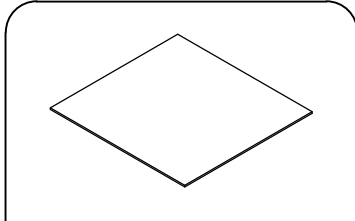

13

3PCS

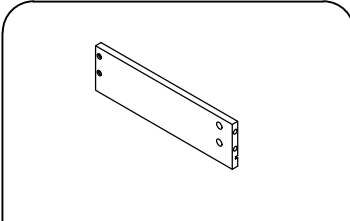

14

3PCS

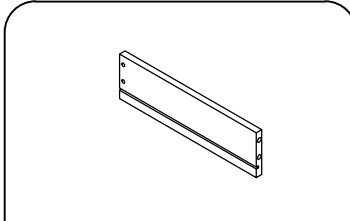

15

3PCS

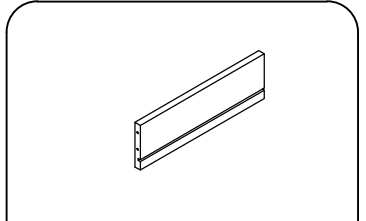

16

3PCS

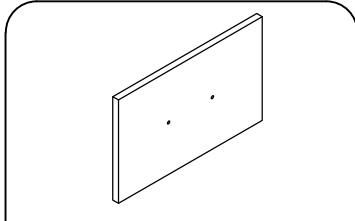

17

3PCS

Hardware List

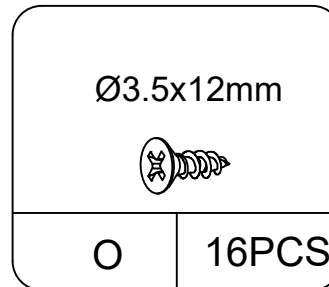
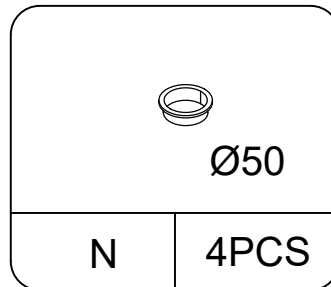
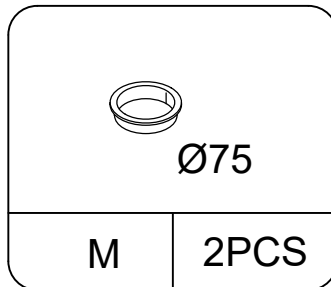
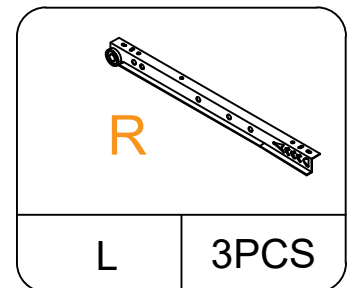
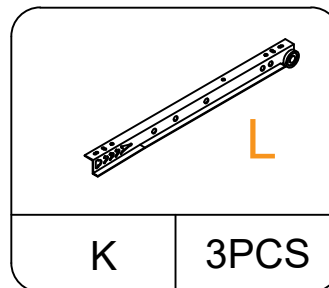
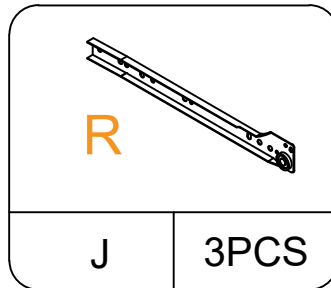
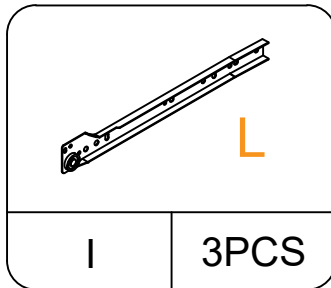
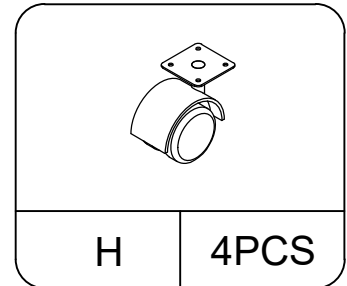
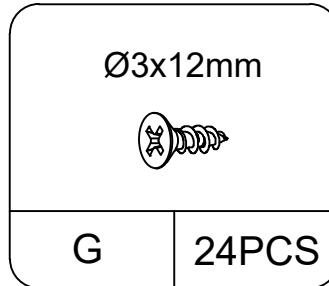
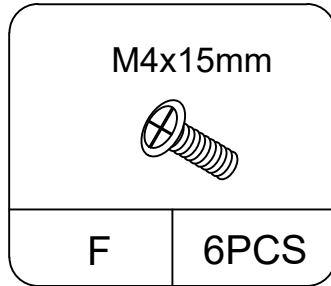
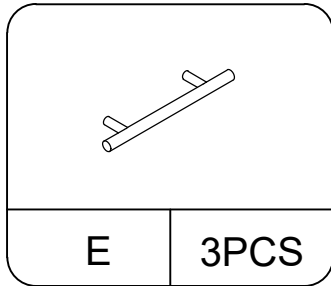
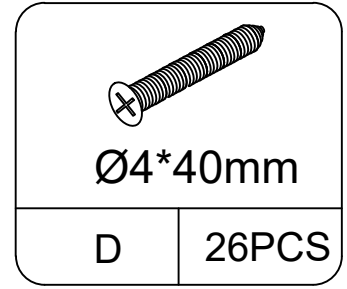
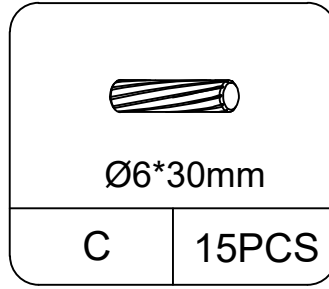
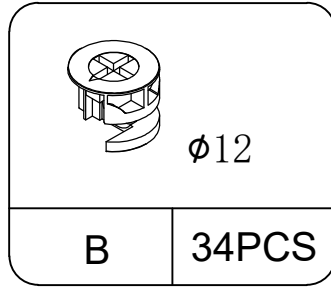
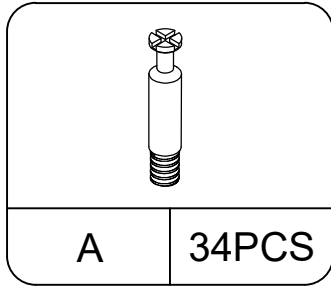

STEP 1

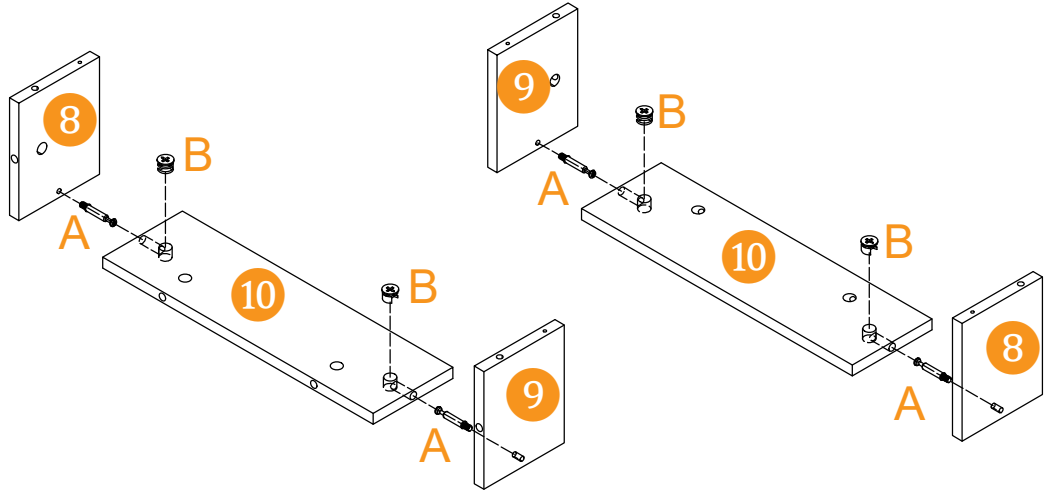
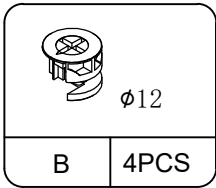
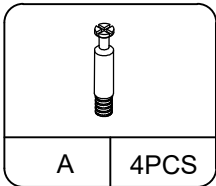

STEP 2

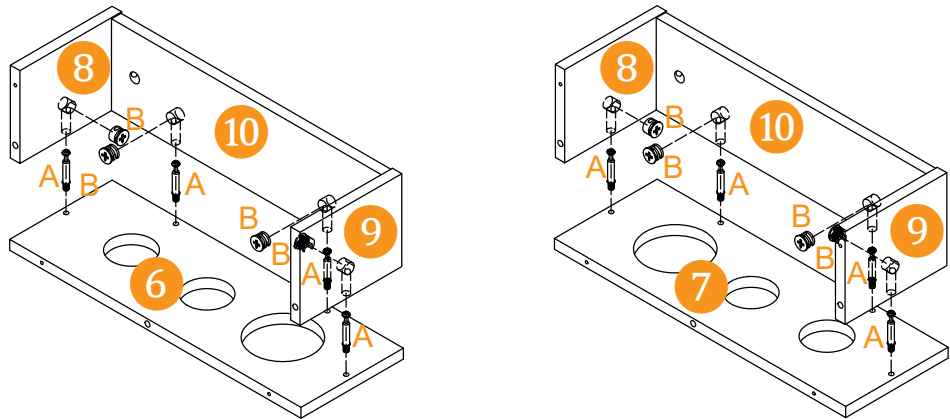
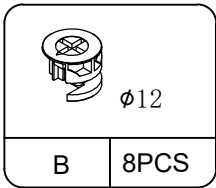
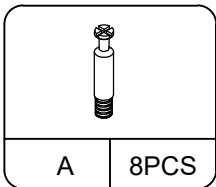

STEP 3

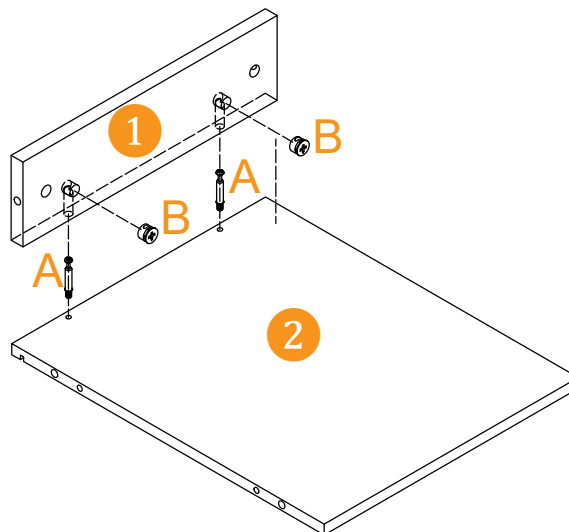
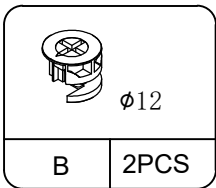
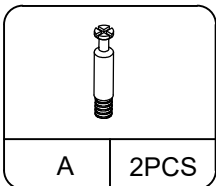

STEP 4

Ø3x12mm			
G	12PCS	I	3PCS

I	3PCS	J	3PCS

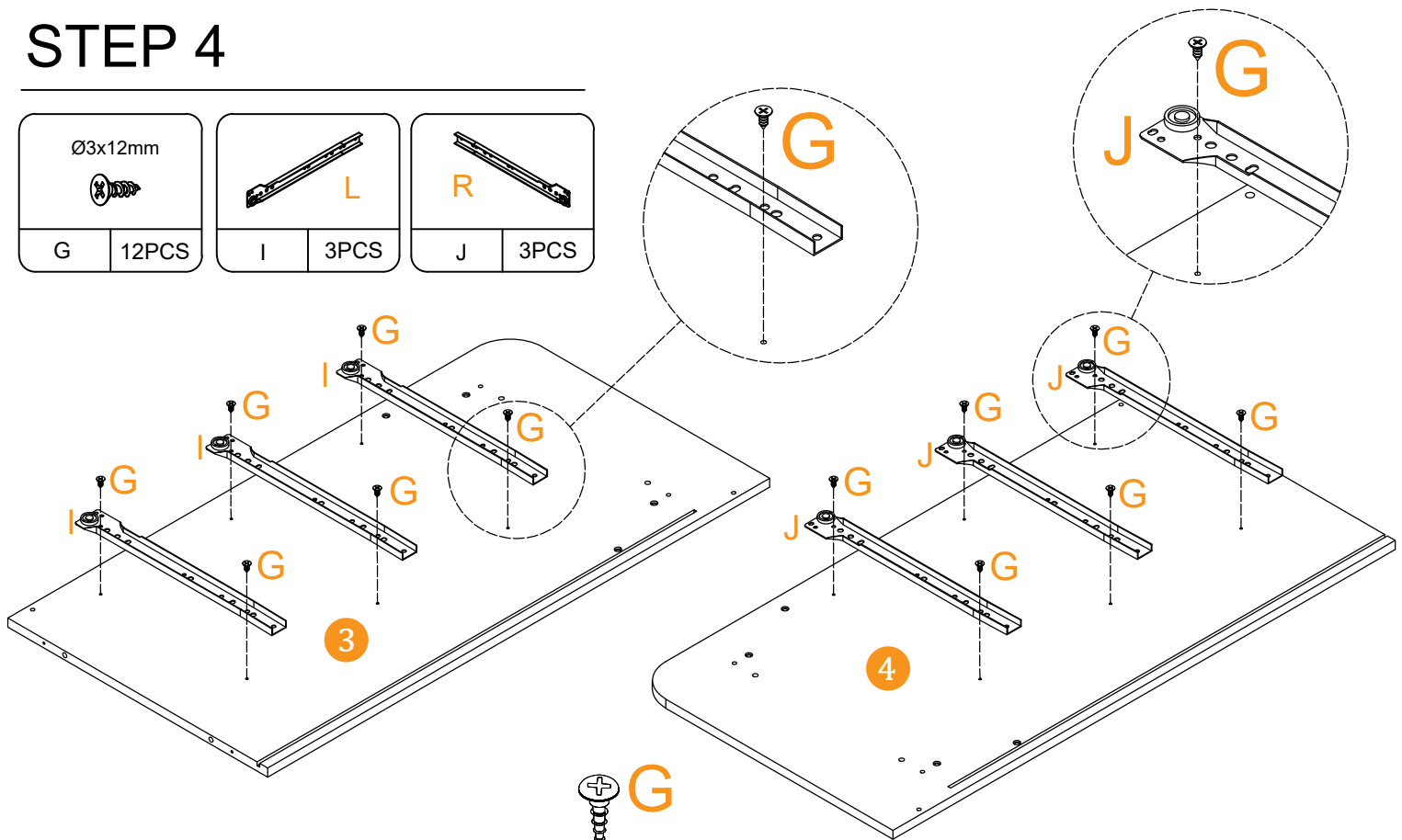

STEP 5

Ø6*30mm			
C	6PCS	D	8PCS

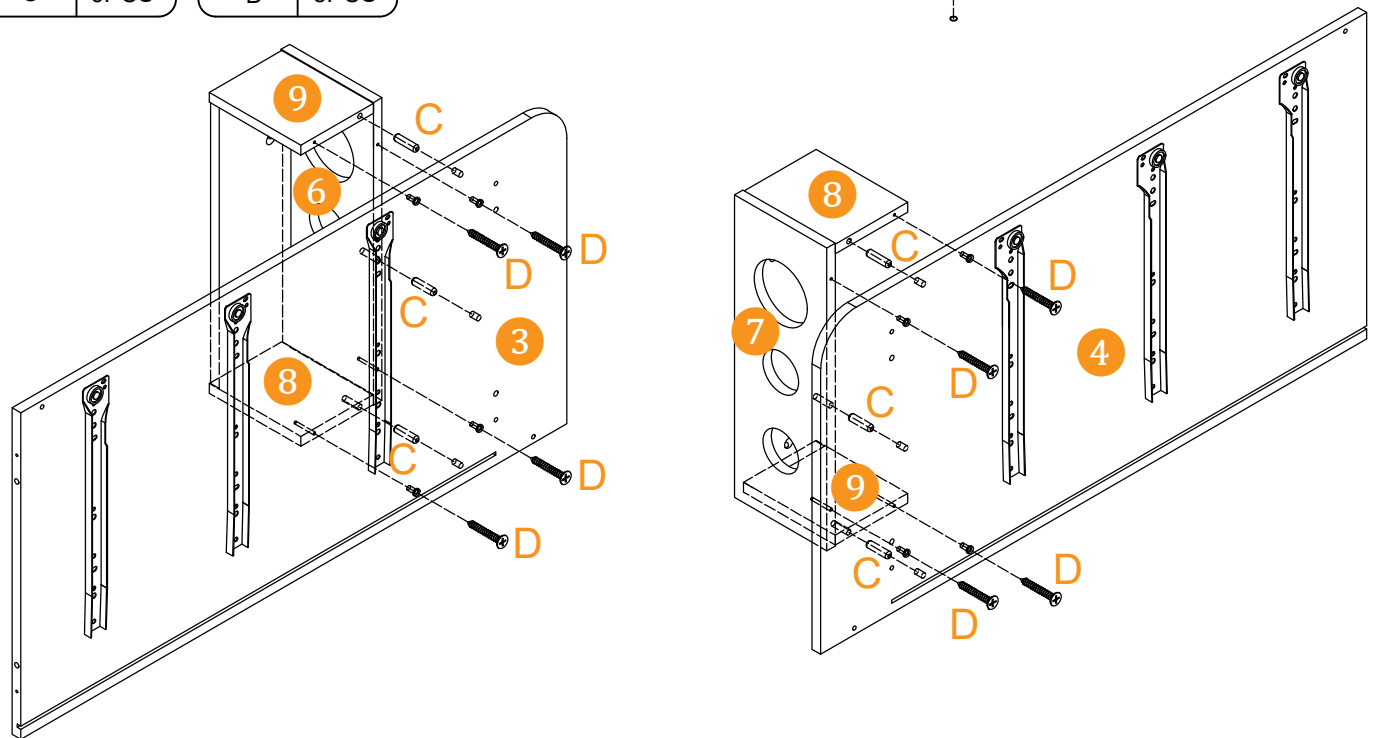

STEP 6

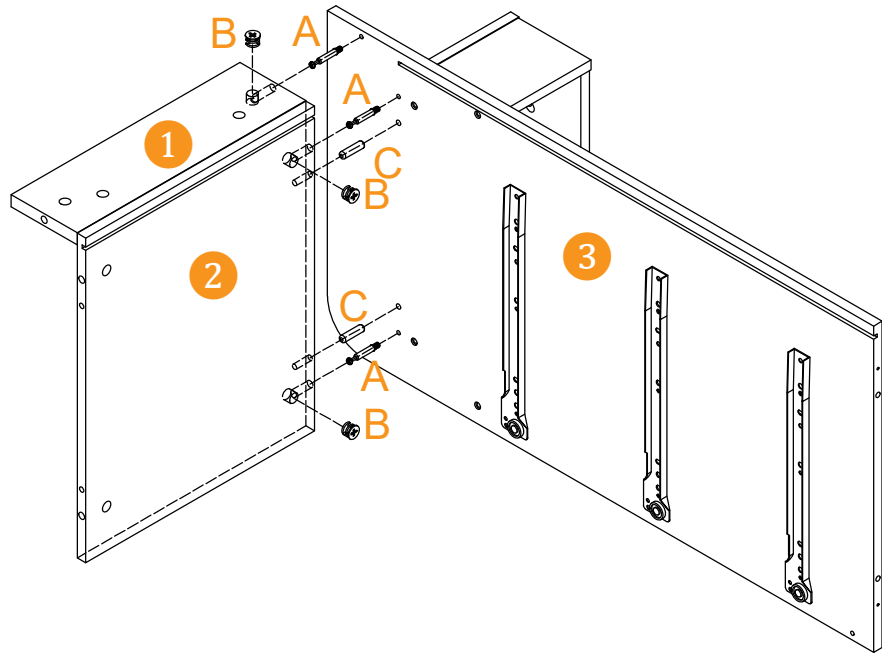
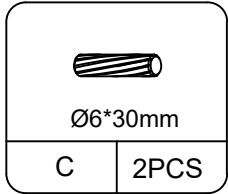
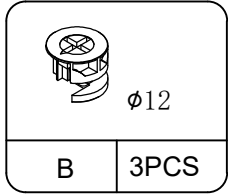
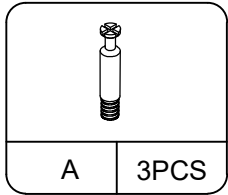

STEP 7

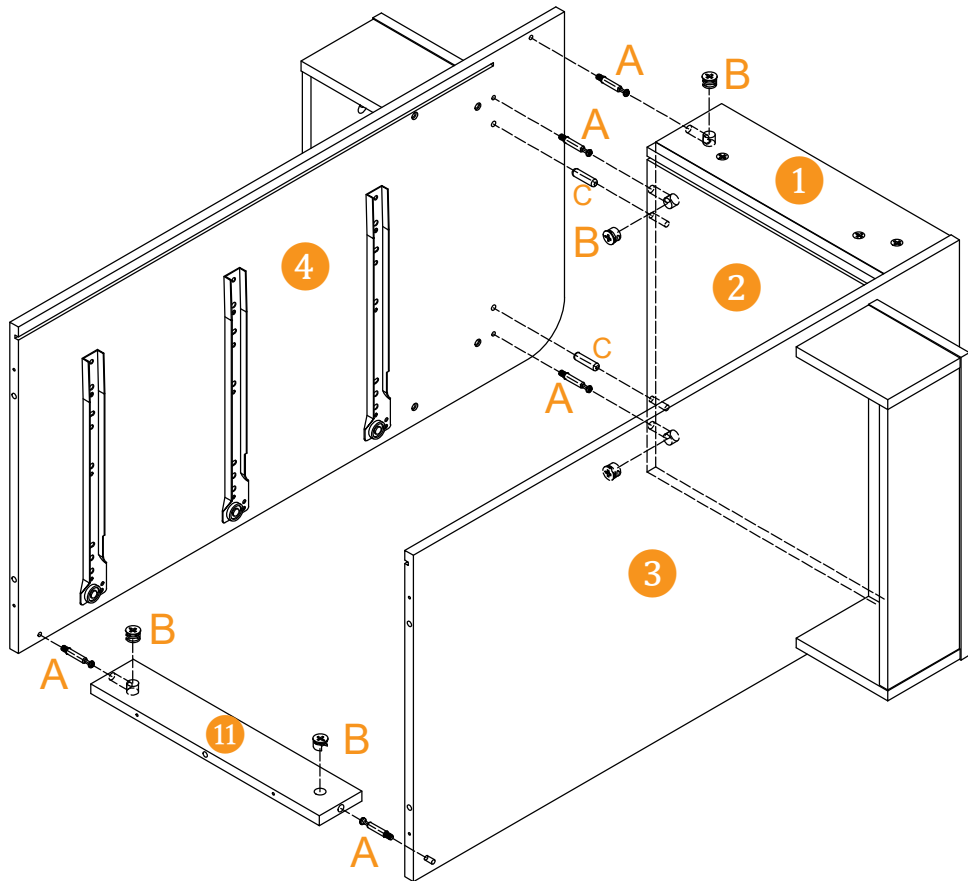
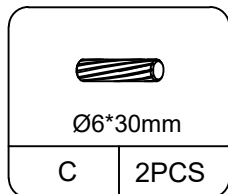
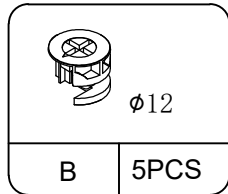
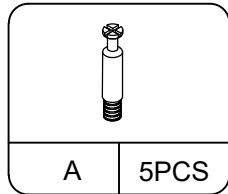

STEP 8

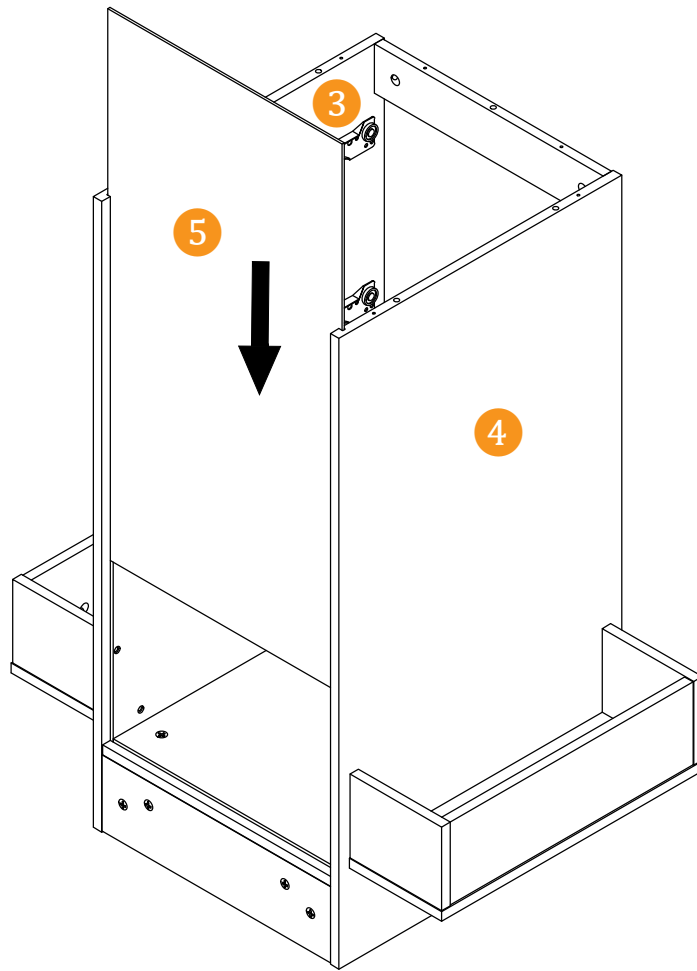

STEP 9

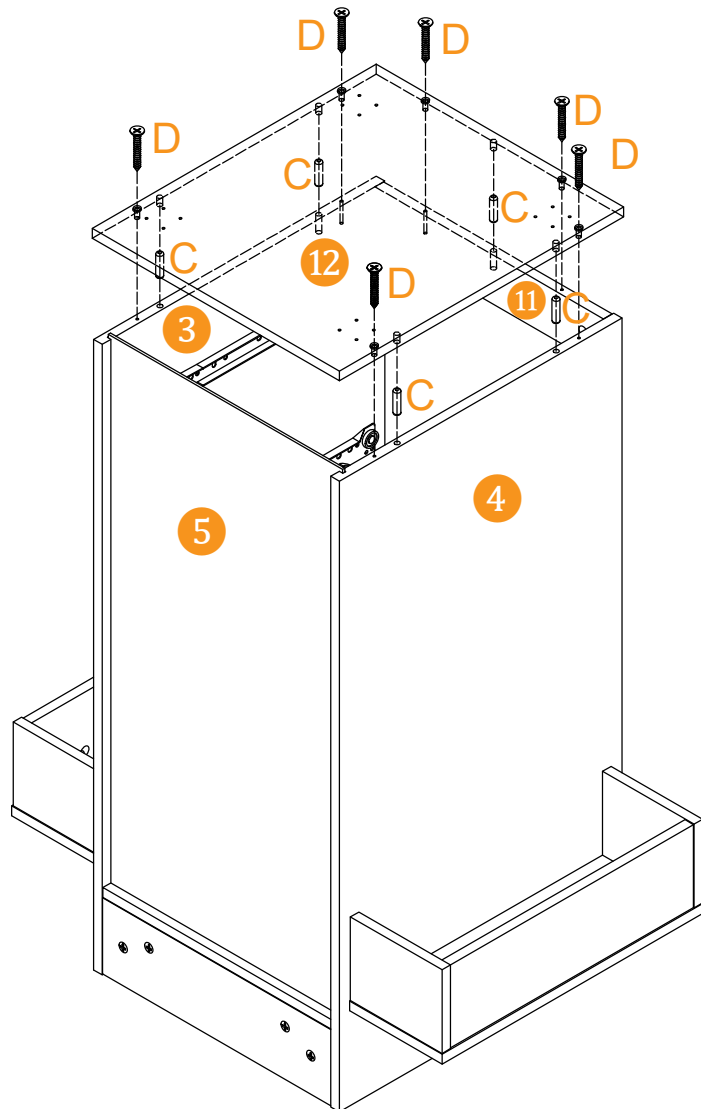
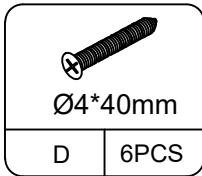
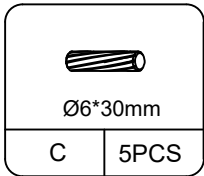

STEP 10

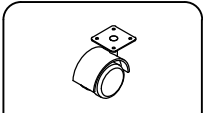

H 4PCS

Ø3.5x12mm



O 16PCS

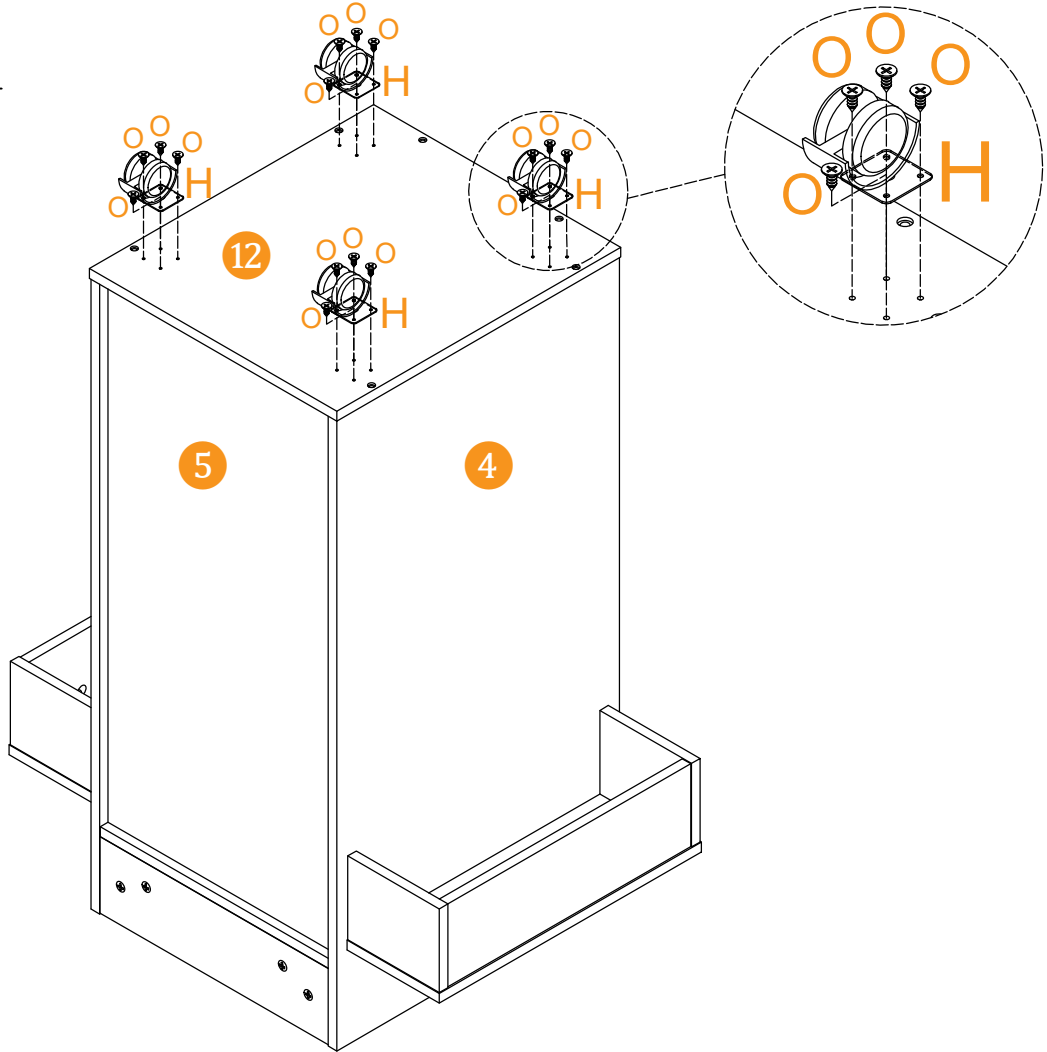

STEP 11



Ø4*40mm

D 12PCS

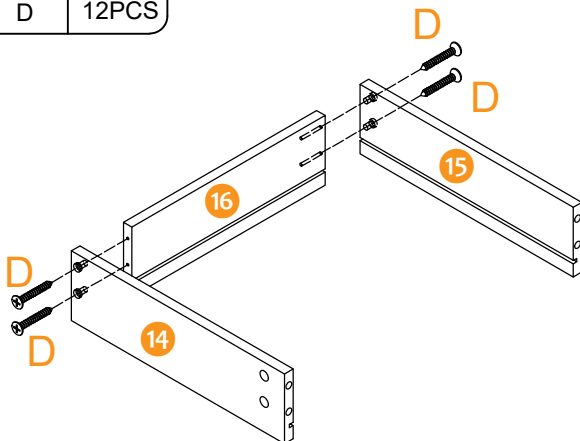

x3PCS

STEP 12

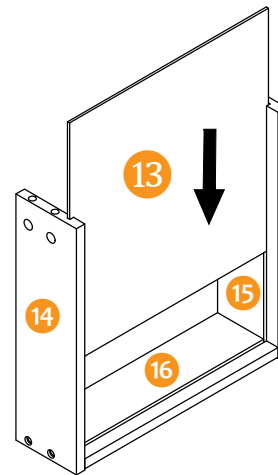

x3PCS

STEP 13

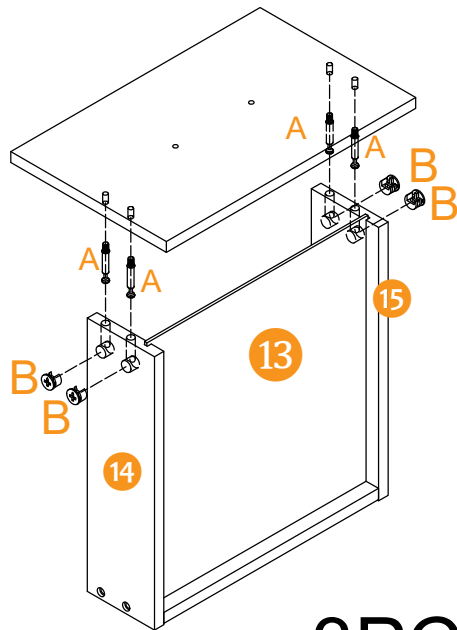
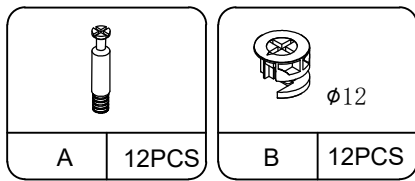

x3PCS

STEP 14

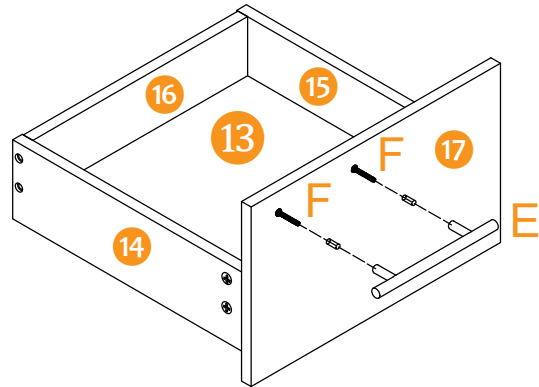
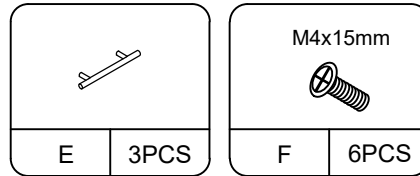

x3PCS

STEP 15

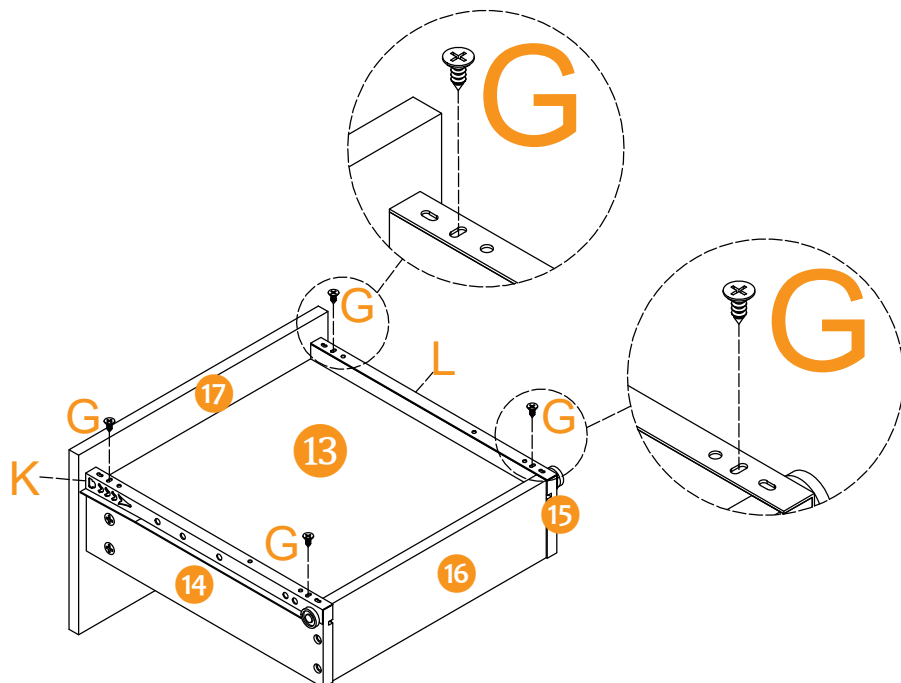
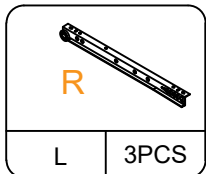
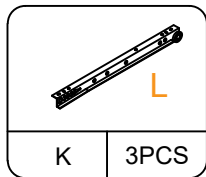
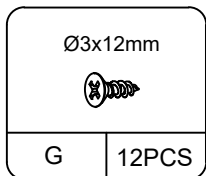

x3PCS

STEP 16

 Ø75	
M	2PCS

 Ø50	
N	4PCS

