

# ASSEMBLY INSTRUCTION

Thank you for purchasing this quality product. Be sure to check all packing material carefully for small parts which may have come loose inside the carton during shipment. Separate, identify and count all parts and hardware. Compare with the parts list to be sure all parts are present.

**IMPORTANT : PLEASE READ INSTRUCTION BEFORE STARTING THE ASSEMBLY.**

**"DO NOT TIGHTEN SCREWS UNTIL COMPLETELY ASSEMBLED"**

**"DO NOT OVERTIGHT ANY HARDWARE"**

**WARNING : SMALL PARTS AND HARDWARE NOT FOR CHILDREN UNDER 3 YEARS. ADULT ASSEMBLY REQUIRED.**

## TABLE OF CONTENTS

HARDWARE LIST	PAGE 2
PARTS LIST	PAGE 3 - 4
IMPORTANT NOTICE	PAGE 5
PARTS' LOCATION	PAGE 6
ASSEMBLY STEPS	PAGE 7 - 13

## ASSEMBLY TOOLS REQUIRED

**1.Screwdriver (not provide)**

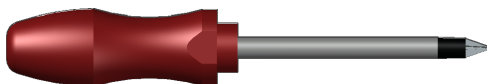

**2.Hammer (not provide)**

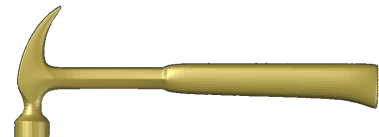



**Skip the power drill this time.**

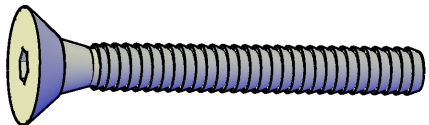
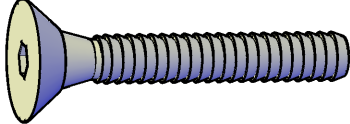
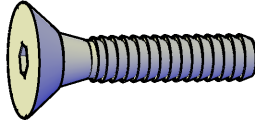
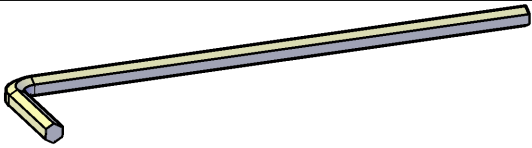

# ASSEMBLY INSTRUCTION

## HARDWARES LIST

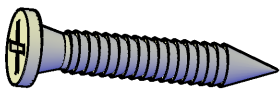
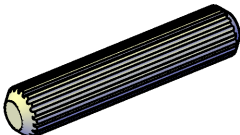
ITEM	DESCRIPTION	DRAWING	QTY
A	JCBC SCREW M6 x 90 MM		32 PCS
B	JCBC SCREW M6 x 70 MM		20 PCS
C	JCBC SCREW M6 x 55 MM		20 PCS
D	M4 ALLEN KEY		1 PC
E	BARREL NUT M6 x 13 MM		42 PCS
F	CSK SCREW M4 x 25 MM		26 PCS
G	WOOD DOWEL M10 x 40 MM		42 PCS

# ASSEMBLY INSTRUCTION

## PARTS LIST

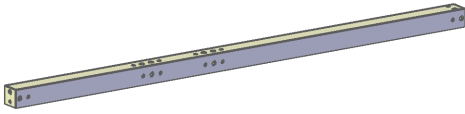
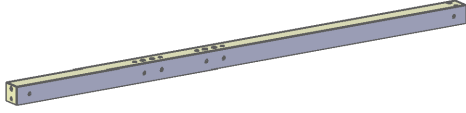
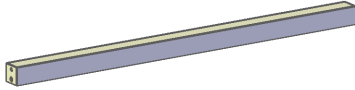
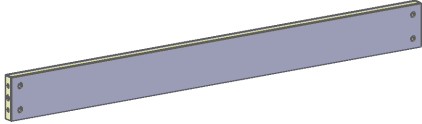
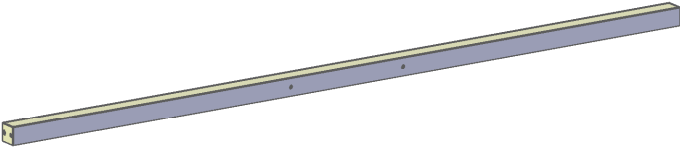
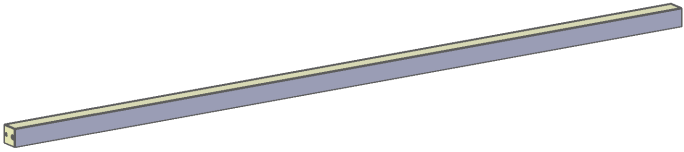
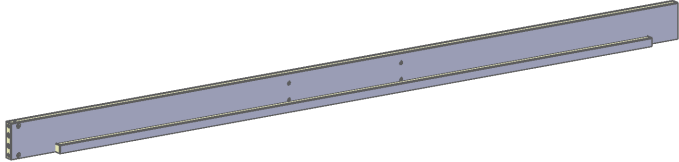
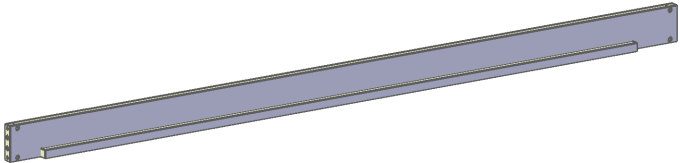
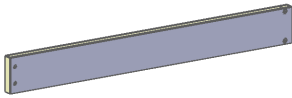
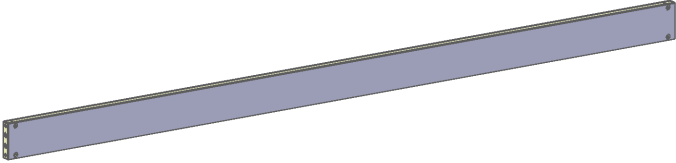
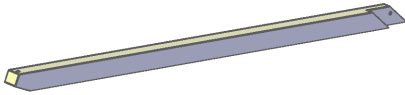
ITEM	DESCRIPTION	DRAWING	QTY
1	POST (i)		2 PCS
2	POST (ii)		2 PCS
3	END RAIL		4 PCS
4	END PANEL		4 PCS
5	BOTTOM SIDE RAIL (i)		1 PC
6	BOTTOM SIDE RAIL (ii)		1 PC
7	FRONT SIDE RAIL WITH CLEAT		1 PC
8	BACK SIDE RAIL WITH CLEAT		1 PC
9	FRONT SAFETY RAIL		2 PCS
10	BACK SAFETY RAIL		1 PC
11	TOP RAIL (i)		2 PCS

# ASSEMBLY INSTRUCTION

## PARTS LIST

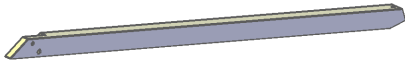
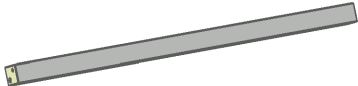
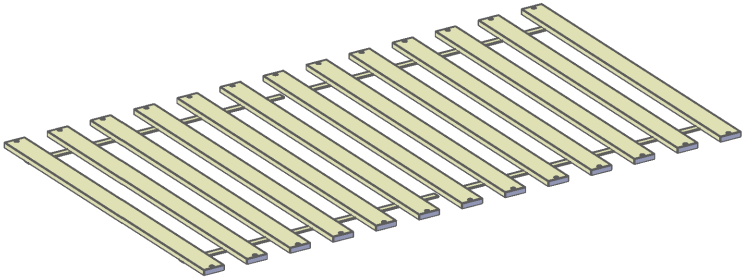
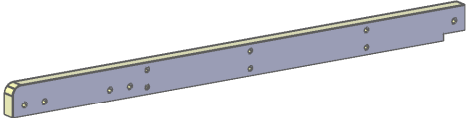
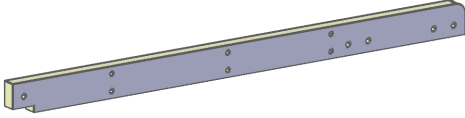
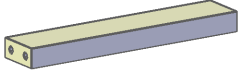
ITEM	DESCRIPTION	DRAWING	QTY
12	TOP RAIL (ii)		2 PCS
13	TOP SUPPORT STRIP		1 PC
14	SLAT		1 PC
15	LADDER SIDE (R)		1 PC
16	LADDER SIDE (L)		1 PC
17	LADDER STEP		3 PCS

# ASSEMBLY INSTRUCTION

## PARTS LOCATION

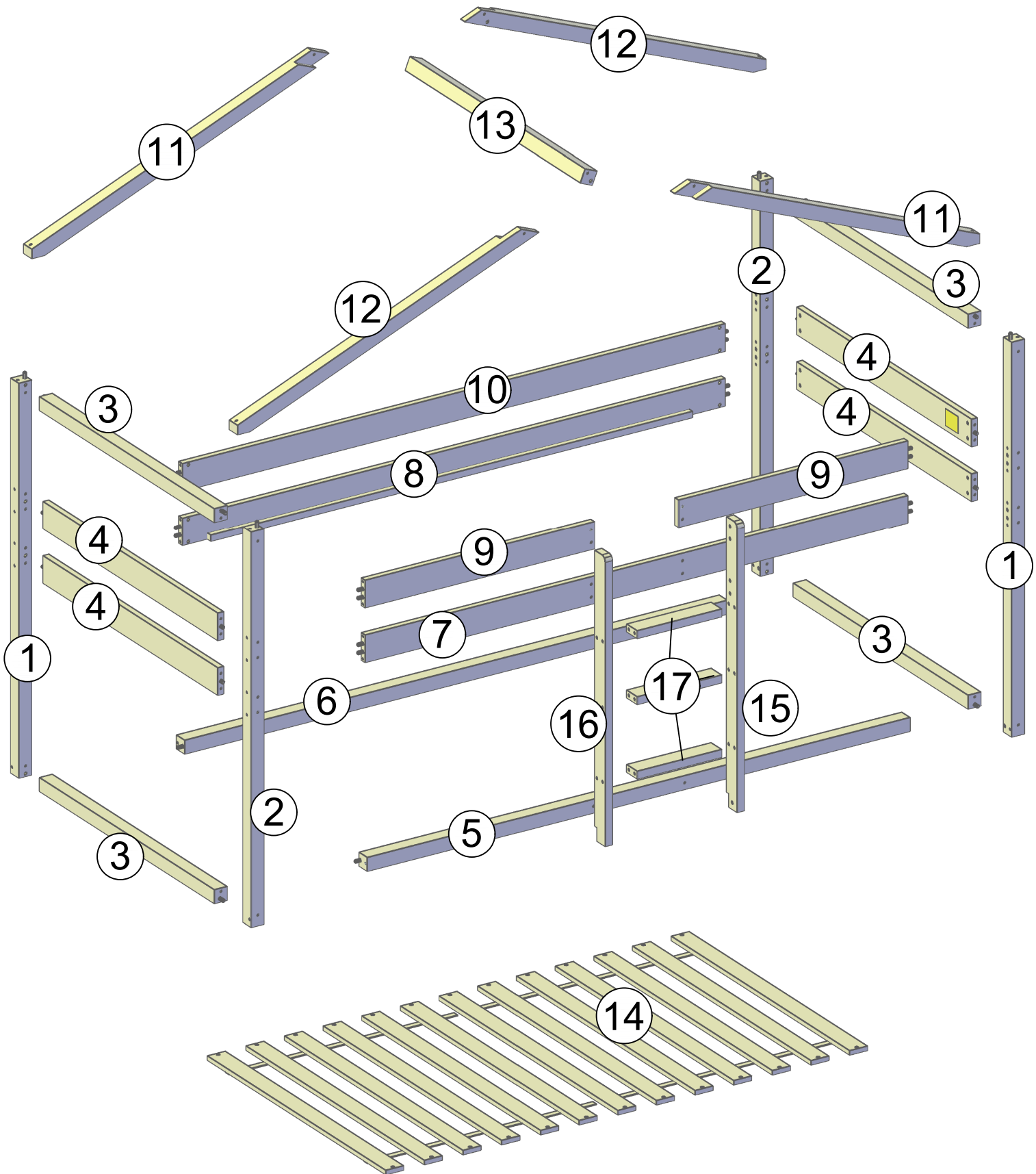

# 80142 ASSEMBLY INSTRUCTION

## **IMPORTANT NOTICE**

- Use only Mattresses - 74" - 75" long and 37 1/2" - 38 1/2" wide on the upper bunk.
- Use only Mattresses - 74" - 75" long and 38" - 38 1/2" wide on the lower bunk.
- Ensure thickness of mattresses does not exceed 7" and mattresses is at least 5" below upper edge of guardrails.
- Check that you have all parts and hardware before assembly. Parts apparently missing are often found in the packing materials.
- Replacement parts, including additional guardrails, may be obtained from any of retailers purchased from.

## **SAFETY WARNING**

- Follow the information on the warnings appearing on the upper bunk end structure and on the carton. Do not remove warning label from bed.
- Always use the recommended size mattresses or mattress support, or both, to help prevent the likelihood of entrapment or falls.
- Surface of mattress must be at least 5 in. (127 mm) below the upper edge of guardrails.
- Do not allow children under 6 years of age to use the upper bunk.
- Periodically check and ensure that the guardrail, ladder, and other components are in their proper position, free from damage, and that all connectors are tight.
- Do not allow horseplay on or under the bed and prohibit jumping on the bed.
- Always use ladder for entering and leaving upper bunk.
- Do not use substitute parts. Contact the retailer or dealer for replacement parts.
- Use of a night light may provide added safety precaution for a child using the upper bunk.
- Always use guardrails on both long sides of the upper bunk. If the bunk bed will be placed next to the wall, the guardrail that runs the full length of the bed should be placed against the wall to prevent entrapment between the bed and wall.
- The use of water or sleep flotation mattresses is prohibited.

## **STRANGULATION HAZARD :**

- Do not attach or hang items to any part of the bunk bed that are not designed for use with the bed; for example, but not limited to, hooks, belts, and jump ropes.

Keep these instructions for future reference.

## **PROHIBIT MORE THAN ONE PERSON ON UPPER BUNK.**

# ASSEMBLY INSTRUCTION

## STEP 1

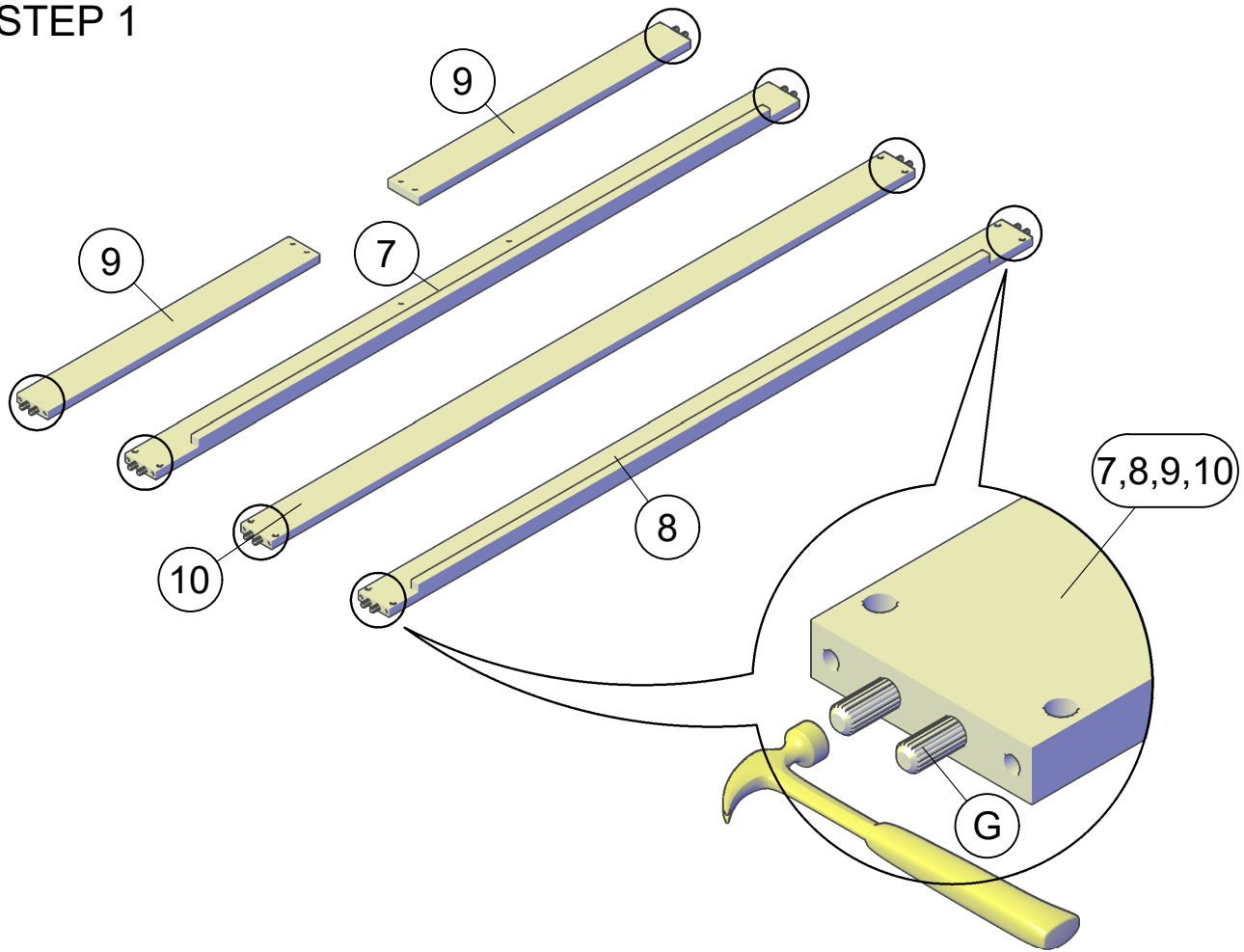

## STEP 2

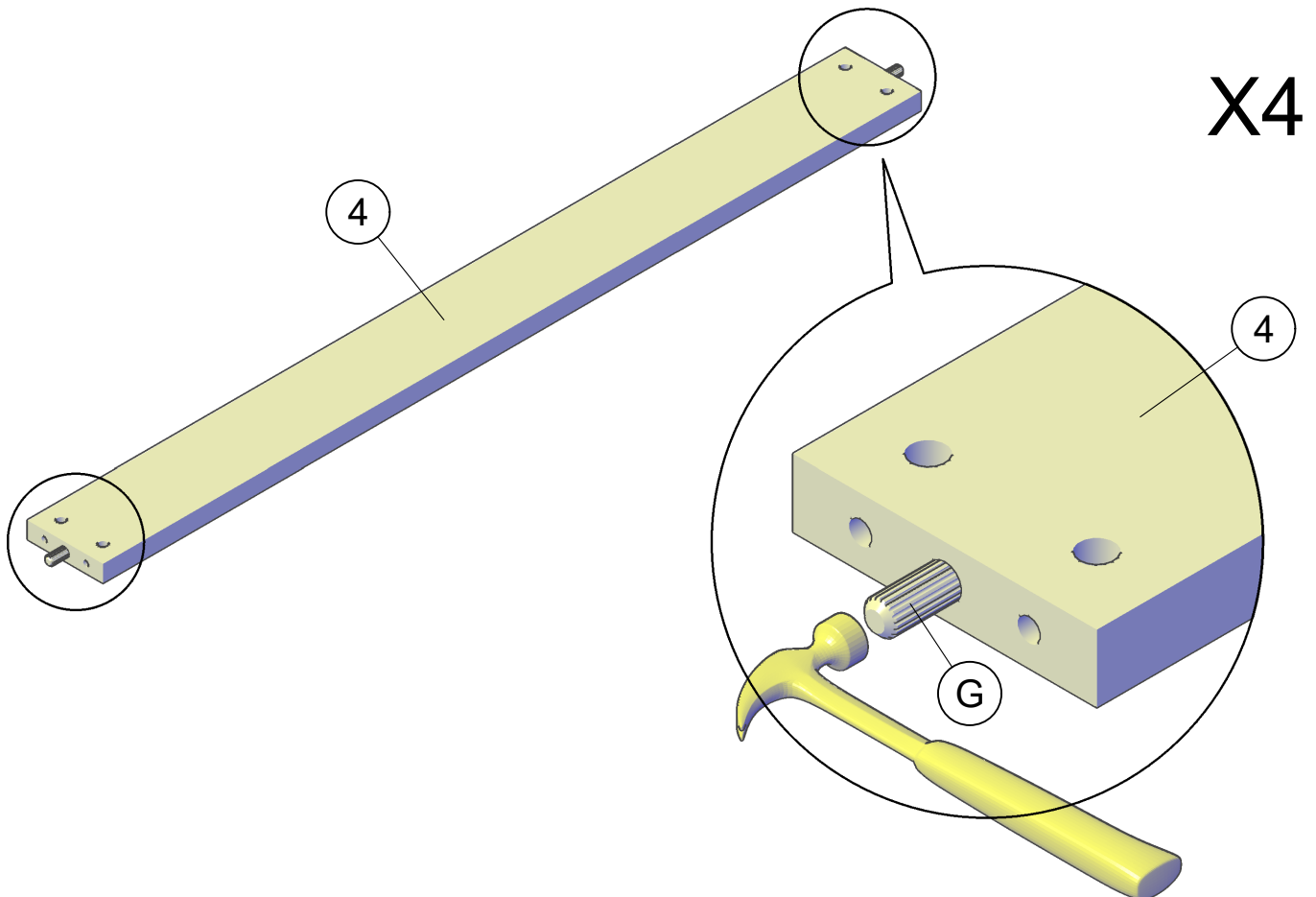

# ASSEMBLY INSTRUCTION

## STEP 3

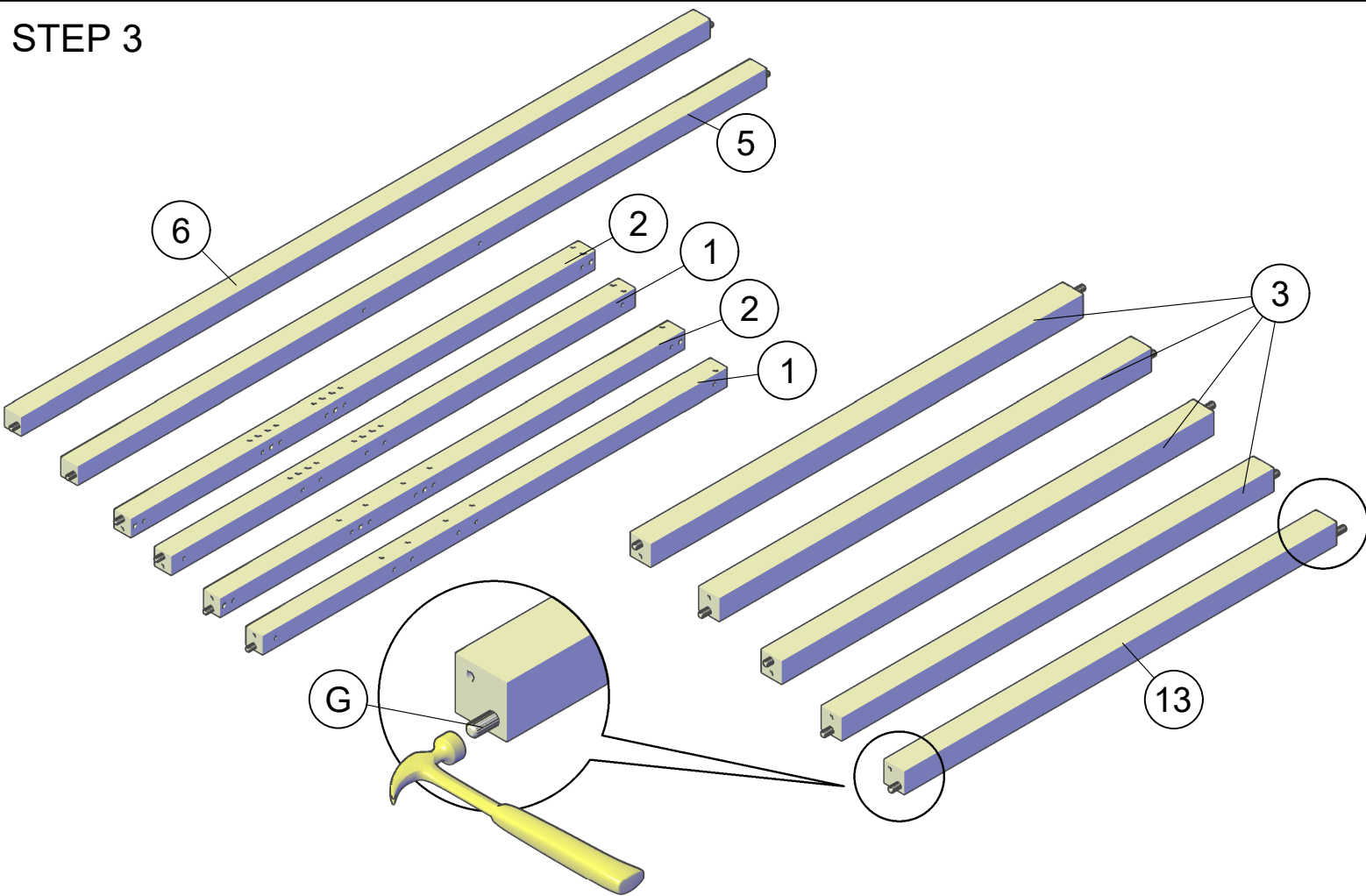

## STEP 4

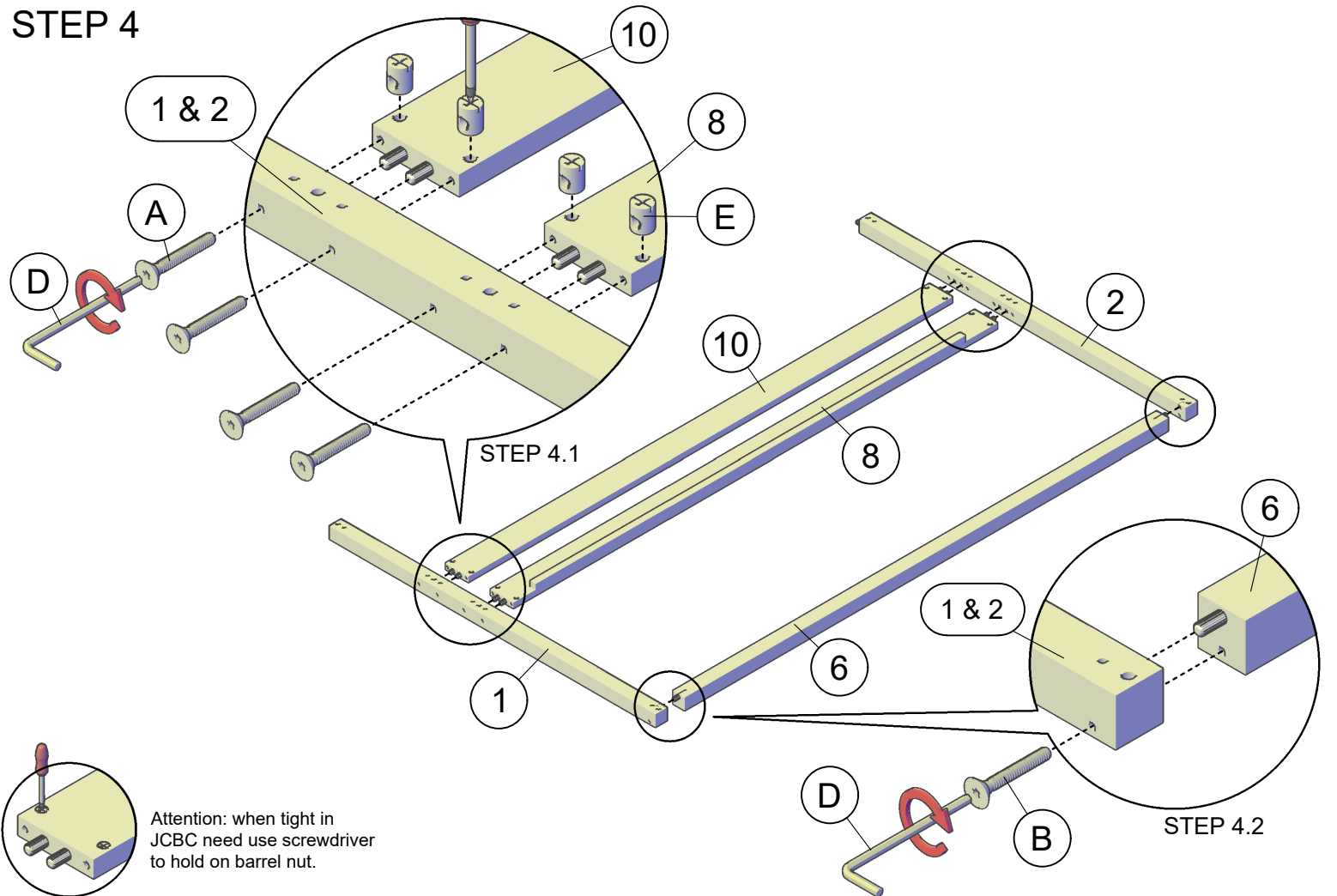

# ASSEMBLY INSTRUCTION

## STEP 5

STEP 5.1

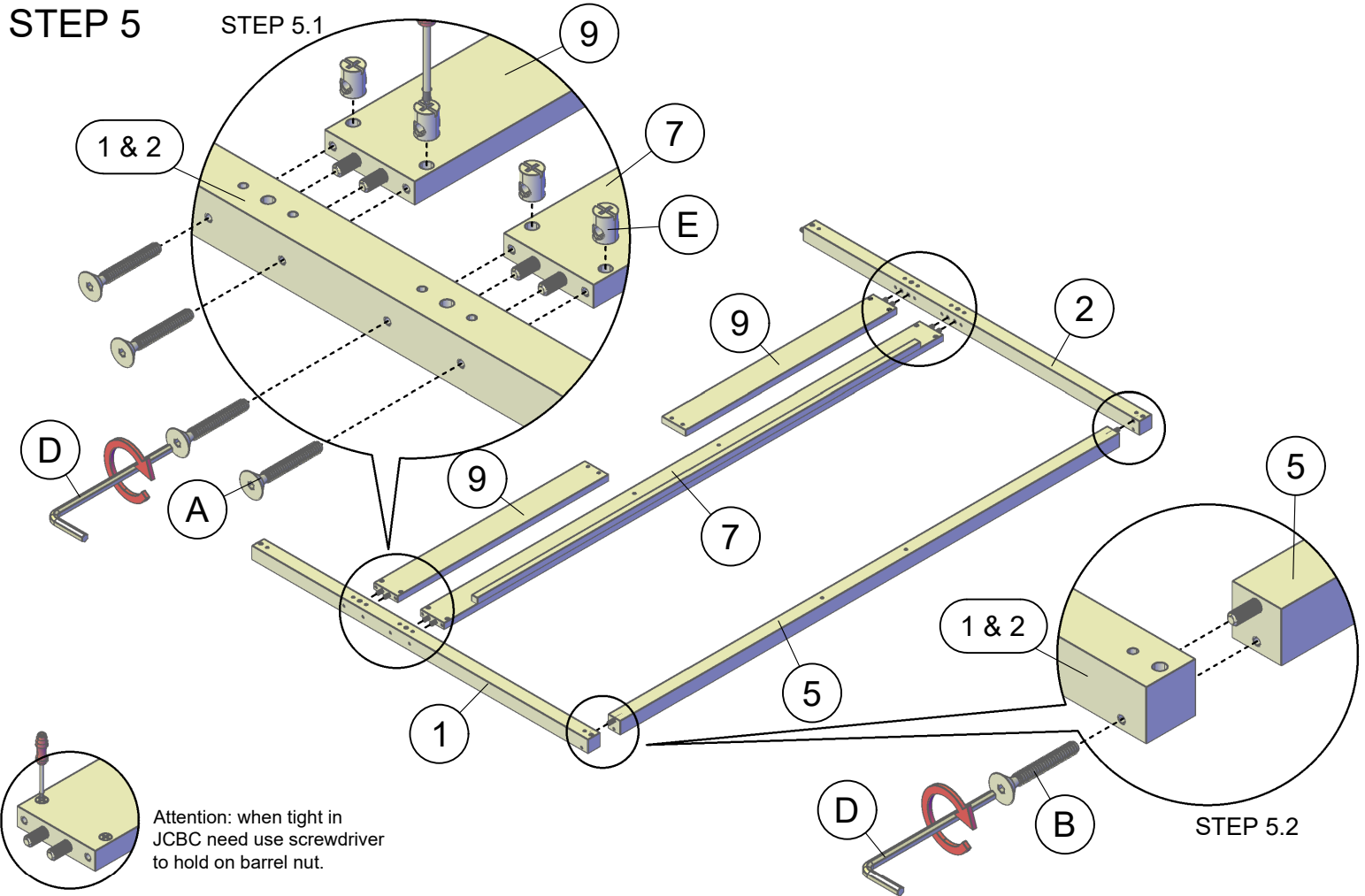

## STEP 6

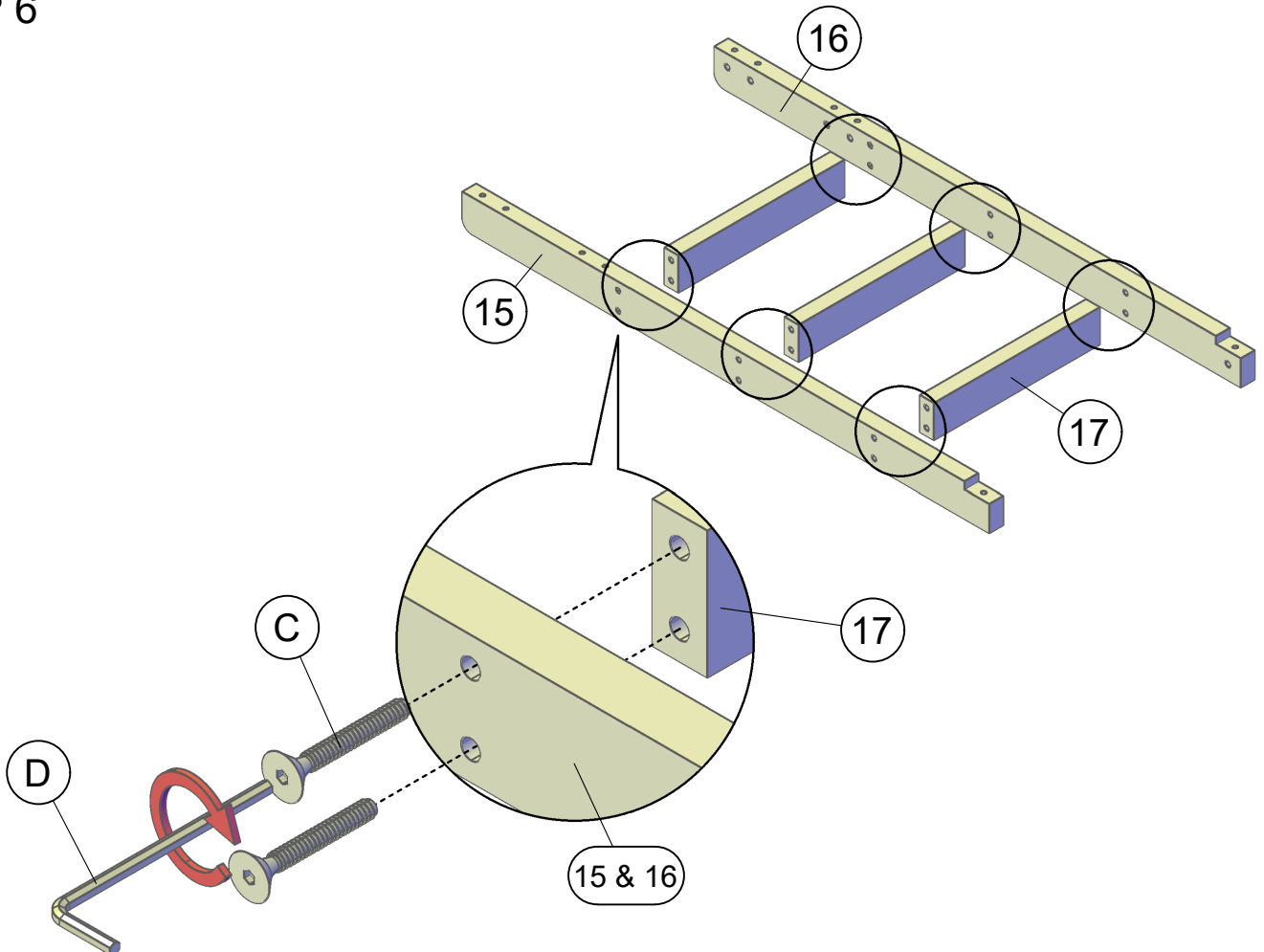

# ASSEMBLY INSTRUCTION

## STEP 7

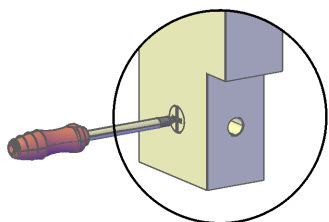
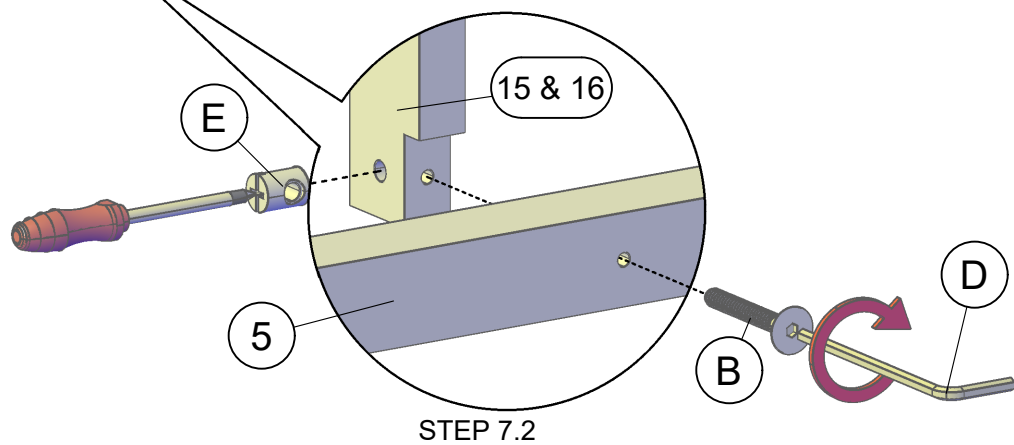
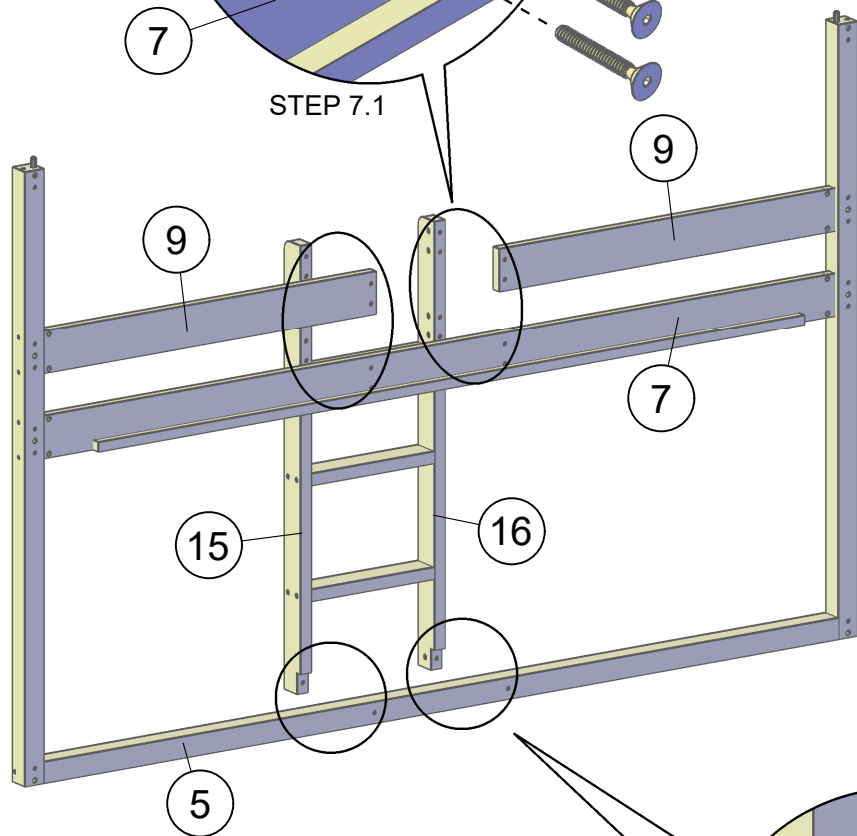
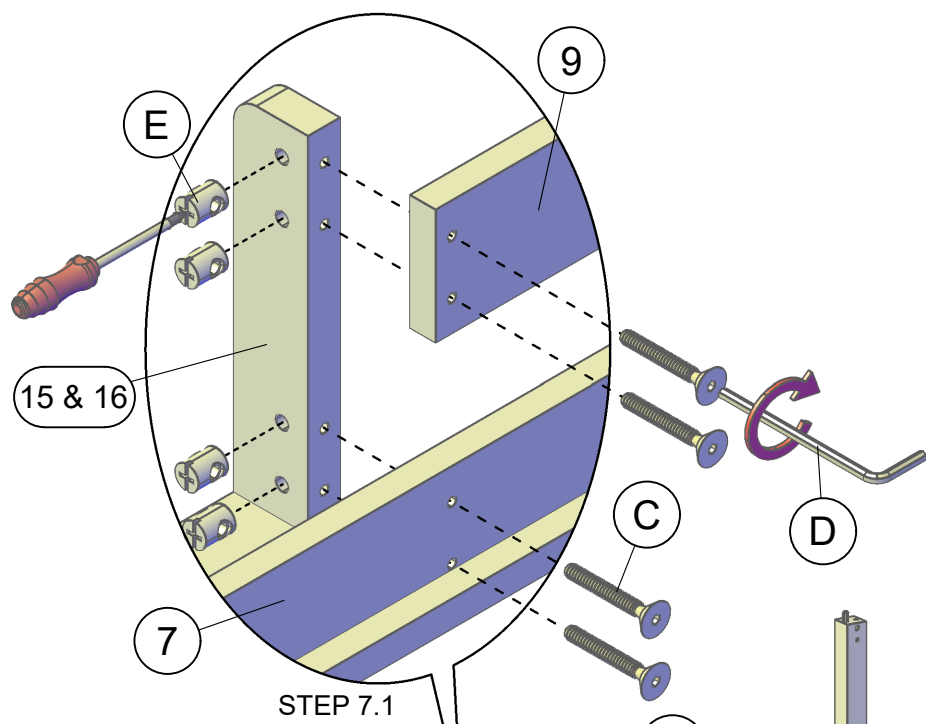

Attention: when tight in JCBC need use screwdriver to hold on barrel nut.

# ASSEMBLY INSTRUCTION

## STEP 8

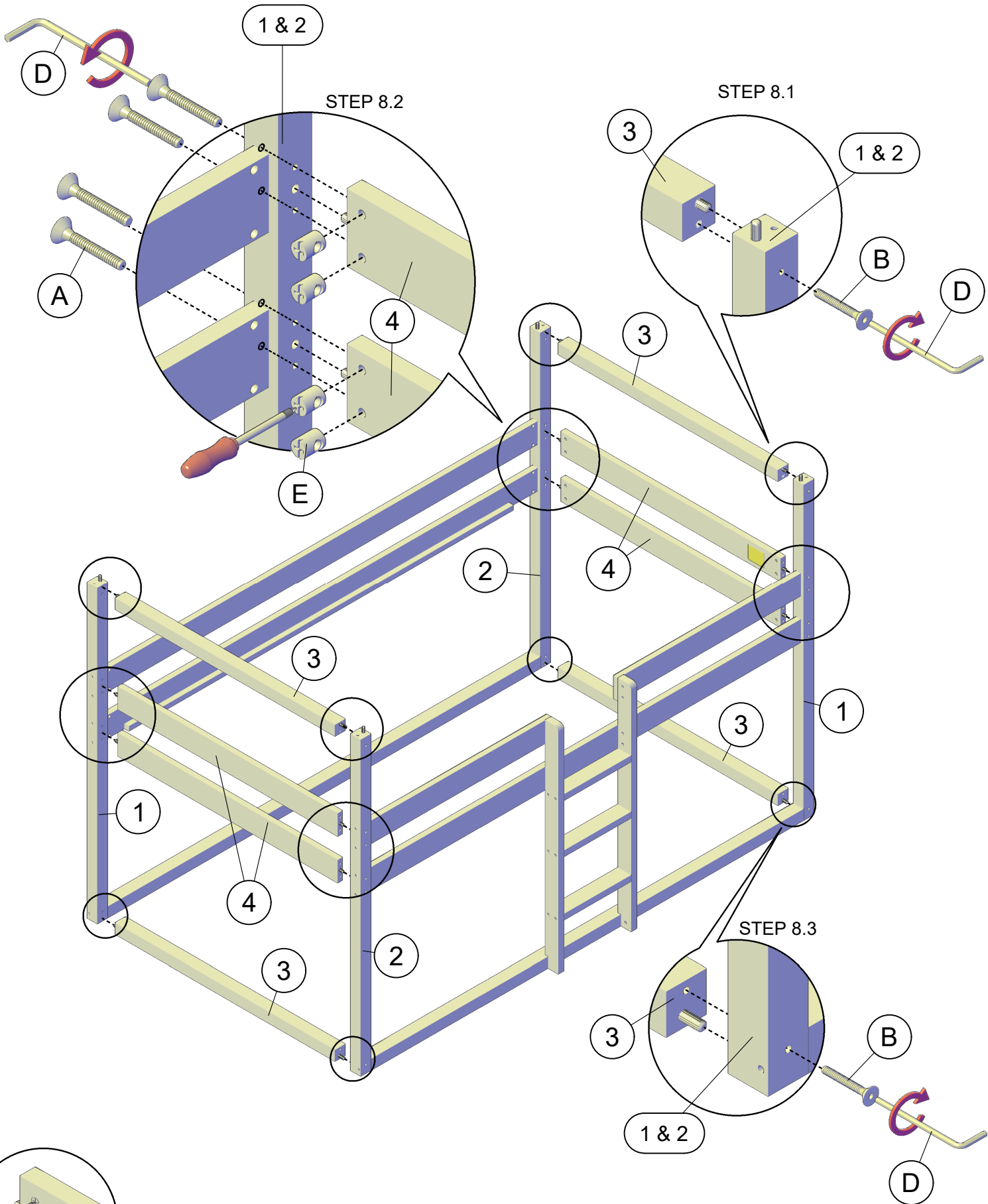

Attention: when tight in JCBC need use screwdriver to hold on barrel nut.

# ASSEMBLY INSTRUCTION

## STEP 9

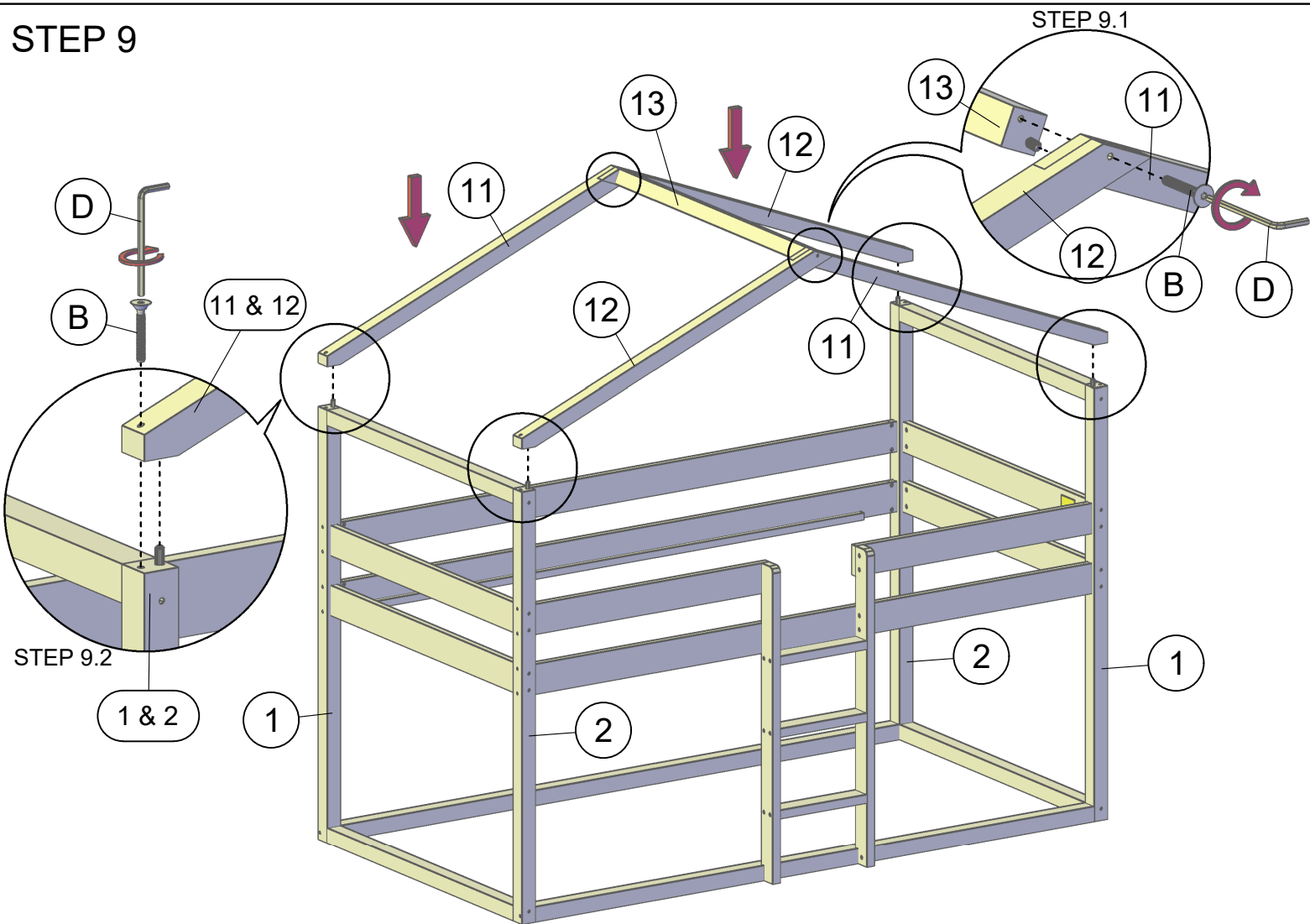

## STEP 10

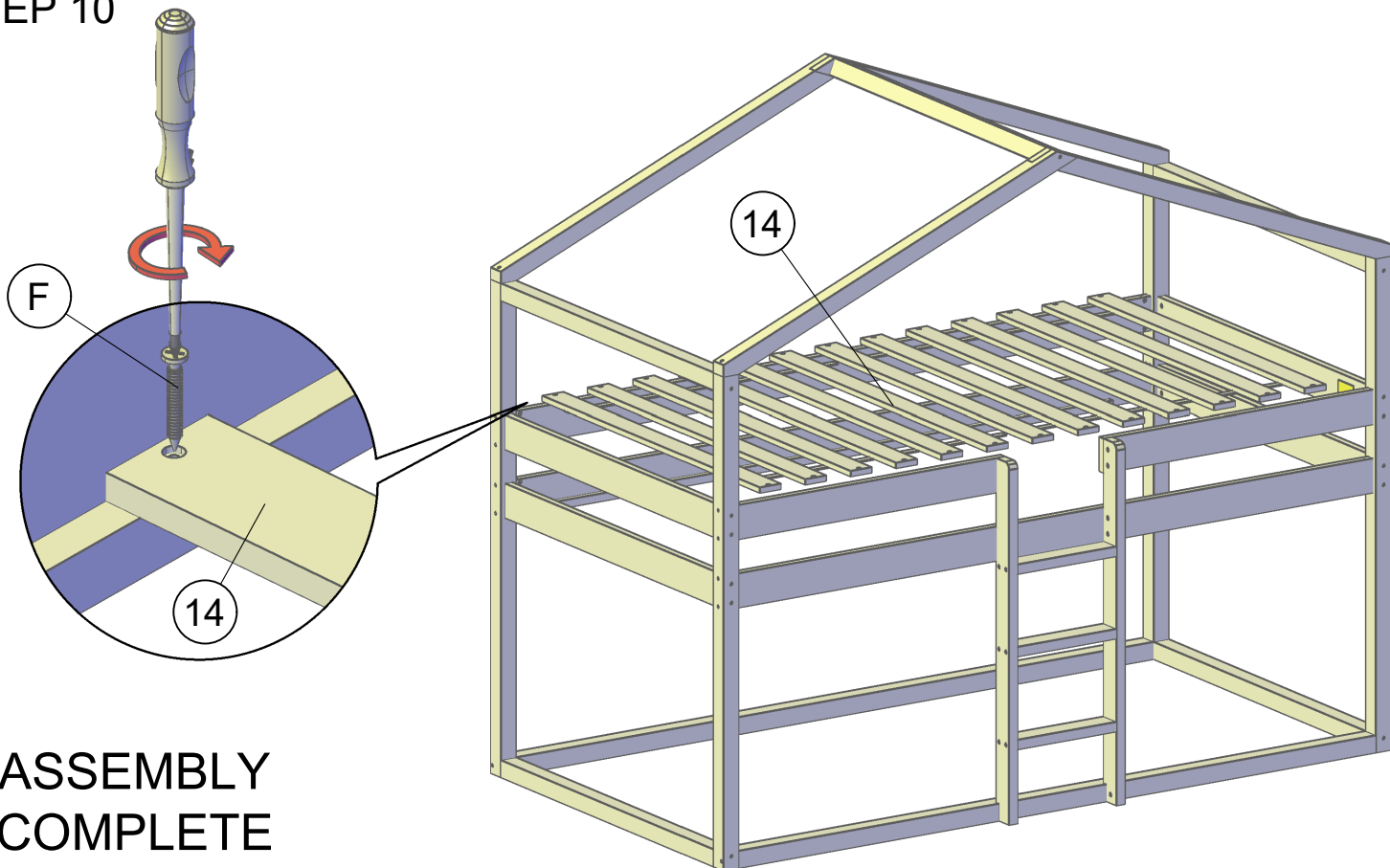

# ASSEMBLY INSTRUCTION

This sticker was stucked at one of the END PANEL (4)



## WARNING

### TO HELP PREVENT

serious or fatal injuries from entrapment or falls

- Never allow a child under 6 years on upper bunk
- Use only mattress which is 74"~75" long and 37 $\frac{1}{2}$ "~38 $\frac{1}{2}$ " wide on upper bunk
- Ensure thickness of mattress does not exceed 7" and mattress surface is at least 5" below upper edge of guardrails
- Use guardrails on both sides of upper bunk

- Prohibit horseplay on or under bed (s)
- Prohibit more than one person on upper bunk
- Use ladder for entering and leaving upper bunk

### STRANGULATION HAZARD:

Never attach or hang items to any part of the bunk bed that are not designed for use with the bed; for example, but not limited to, hook, belts, and jumprobes.

**DO NOT REMOVE THIS LABEL**

