

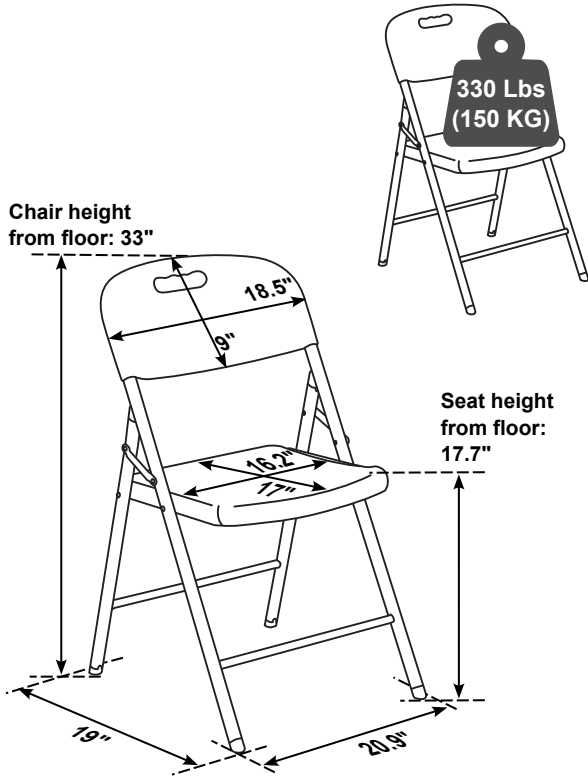

# FOLDING CHAIR

## Owner's Manual

Thank you for purchasing our product

DIMENSIONS AND WEIGHT CAPACITY	WARNINGS
 <p>The diagram shows a folding chair with the following dimensions: Chair height from floor: 33"; Backrest width: 18.5"; Backrest depth: 9"; Seat width: 16.2"; Seat depth: 17"; Front leg width: 19"; Rear leg width: 20.9"; Seat height from floor: 17.7". A weight capacity label on the backrest indicates 330 Lbs (150 KG).</p>	<ul style="list-style-type: none"><li>• Do not exceed the indicated weight limit.</li><li>• Sit only one person on the chair.</li><li>• Do not lean back or to the sides, or sit too close to the edge of the seat to avoid going beyond your balance and falling over.</li><li>• Do not stand on the chair or use it as a ladder.</li><li>• Do not sit babies or toddlers alone.</li><li>• If children (3 years and older) are sitting on the chair, always keep close observation on them.</li><li>• Do not use if the product appears to be damaged or defective.</li><li>• Not heeding the above warnings might result in serious injuries.</li><li>• The manufacturer does not assume liability for consequences due to accidents, negligence, exceeding the weight limit, improper use or modifications.</li></ul>
CARE AND MAINTENANCE	STORAGE
<ul style="list-style-type: none"><li>• Do not expose the product to extreme environmental conditions.</li><li>• Please note that the product is prone to discoloration and other forms of regular wear and tear from continue exposure to the elements and direct sunlight.</li><li>• To clean the chair it is recommended to use a soft cloth lightly damped in a solution of smooth soap and water, then dry with a clean towel.</li><li>• Do not use solvents or abrasive materials to clean any part of the chair.</li><li>• Before using a cleaning agent, test on a small hidden area of the chair, like underneath the seat.</li><li>• Inspect the chair completely every 4 months and make sure that all screws are tightened.</li></ul>	<ul style="list-style-type: none"><li>• Fold the chair and store in a dry place.</li><li>• If you own several of these same chairs, do not overstack and secure appropriately.</li></ul>  <p>• DO NOT OVERSTACK • SECURE APPROPRIATELY.</p>