







SKU: KS27ZM-WH / KS27ZM-GY

# ASSEMBLY INSTRUCTION

No	Hardware	Fig	Q.ty
①	Bolt M6 x 70mm		2
②	Bolt M6 x 45mm		2
③	Bolt M6 x 35mm		4
④	Screw M6 x 90mm		2
⑤	Screw M6 x 70mm		2
⑥	Allen Key M4		2

Ⓐ x 1

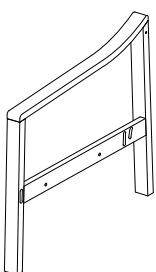

Armrest

Ⓑ x 1

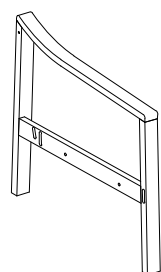

Armrest

Ⓒ x 1

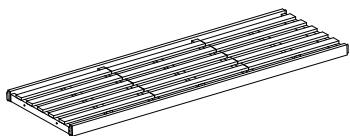

Seat Base

Ⓓ x 1

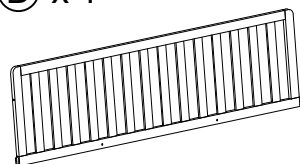

Backrest

Ⓔ x 3

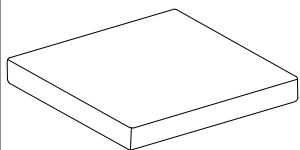

Seat Cushion

Ⓕ x 3

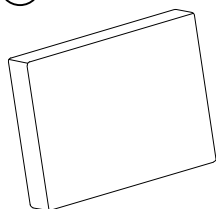

Back Cushion

Ⓖ x 2



Table Leg

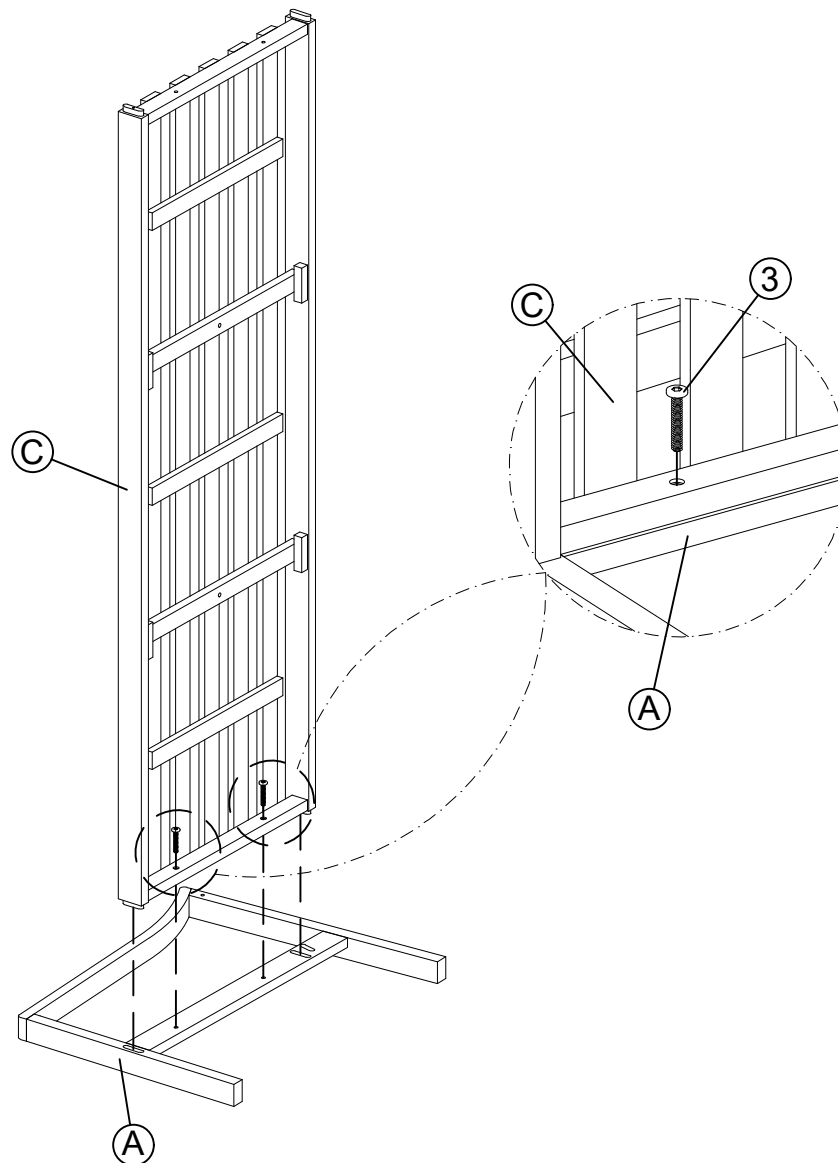
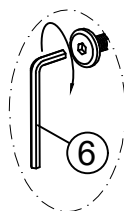

STEP 1



SKU: KS27ZM-WH / KS27ZM-GY

# ASSEMBLY INSTRUCTION

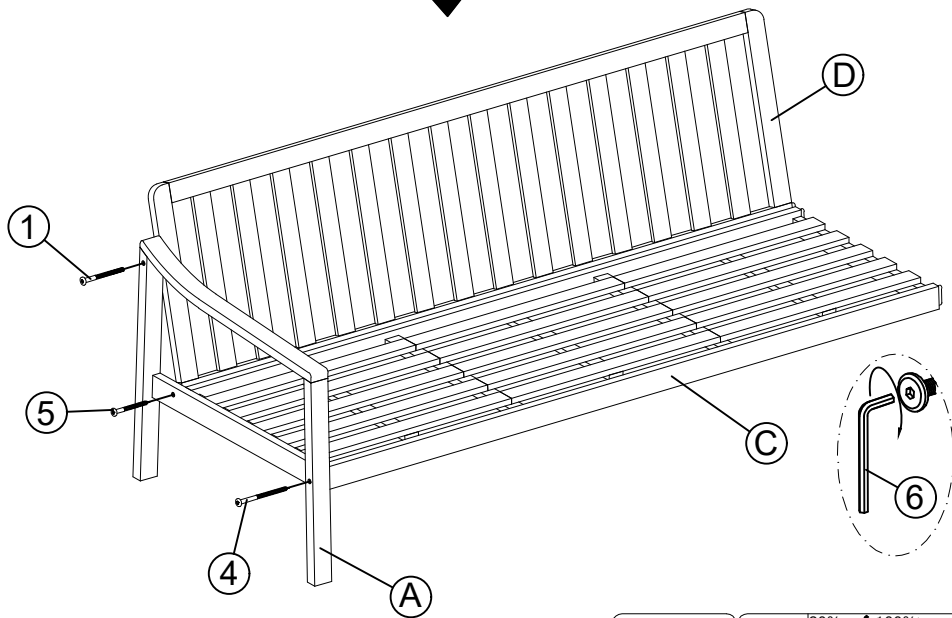
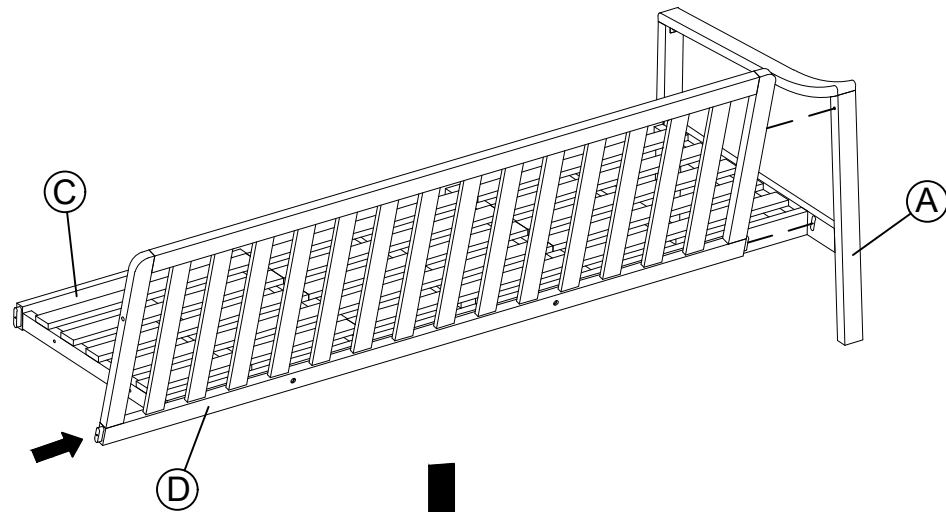

STEP 2

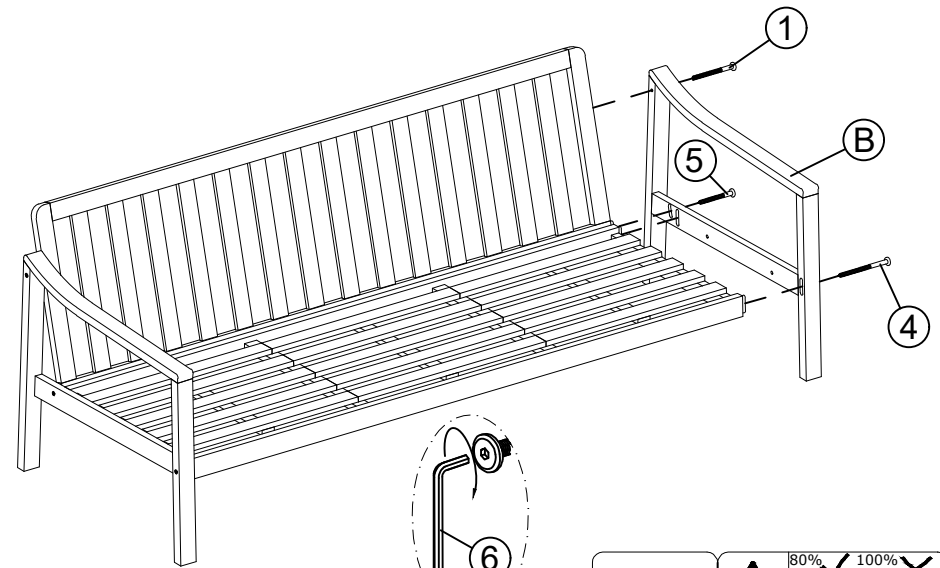
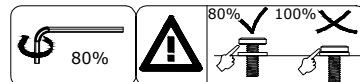

STEP 3

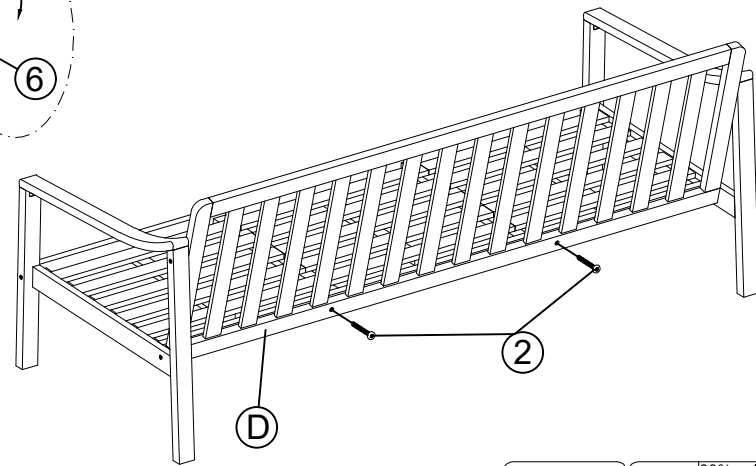
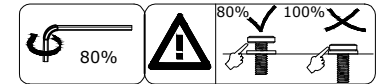

STEP 4

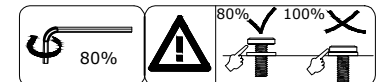

SKU: KS27ZM-WH / KS27ZM-GY

# ASSEMBLY INSTRUCTION

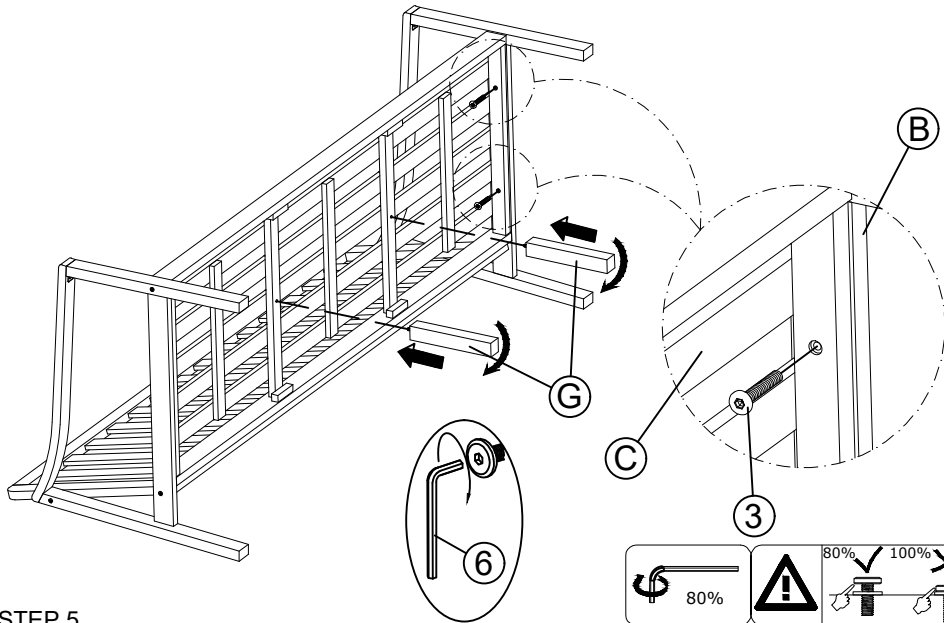

STEP 5

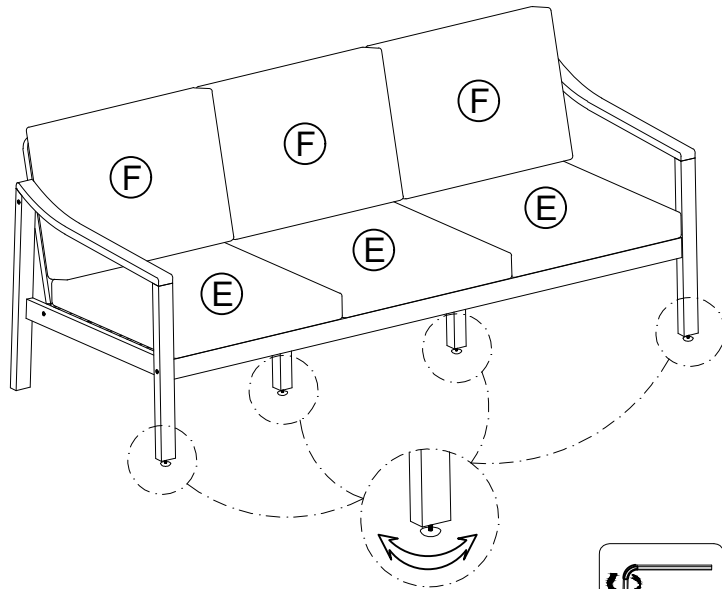

STEP 6

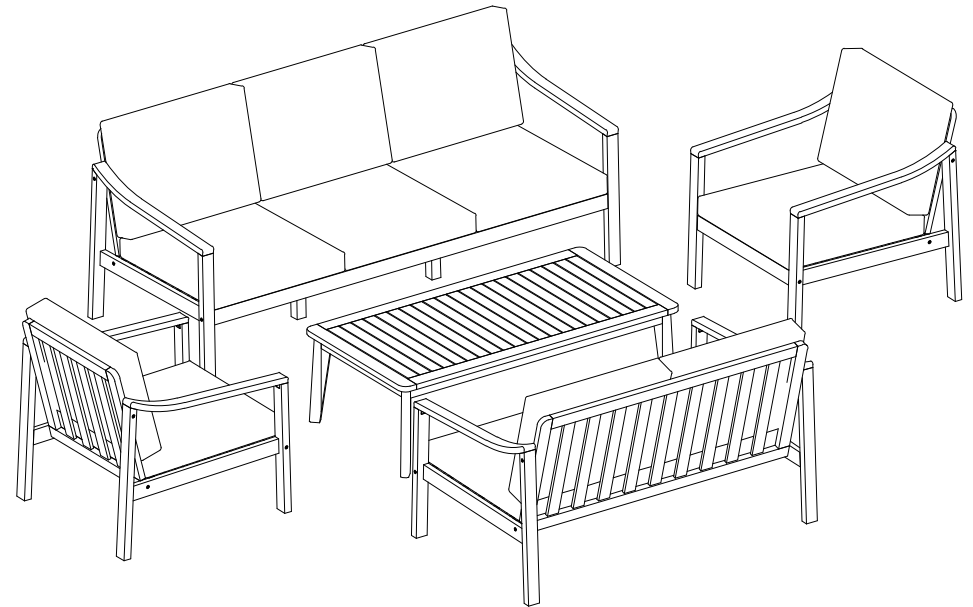

FINISH

# How to Put on the Cushion Cover

1

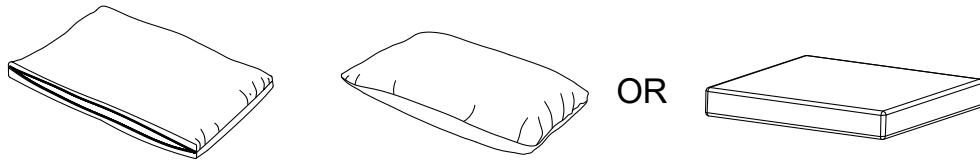

1. Take the cushion covers and inners out of the carton.

2

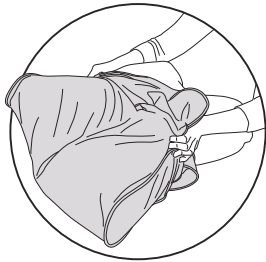

2. Fold the inner in half, pushing the sides together, then begin to slide the cover onto it.

3

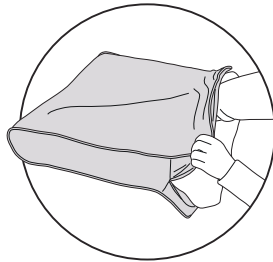

3. Align both far corners, then gently compress insert while fitting cover around it.

4

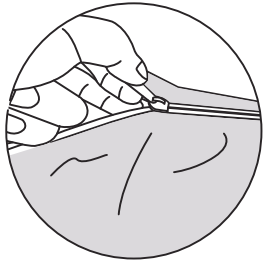

4. To avoid a stuck zipper, please pull the fabric away from the zipper before moving forward.

5

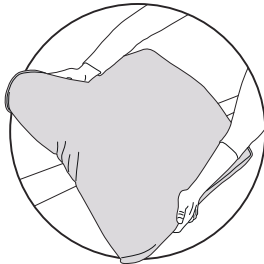

5. When all done, please pat the cushion or give it a little shake to make it more flat.

## Care & Cleaning Guidelines

The covers are machine washable. Before washing, please zip the cover up to avoid catching other clothes. You can clean the dust on the chair / table / footstool with a damp cloth.

## NOTE:

Vacuum compressed cushions,  
Will return to normal shape after 5-7 days use.

