

ASSEMBLY INSTRUCTION

DESCRIPTION: QUEEN BED

Caution: Please read instructions thoroughly before unpacking assembly parts. Sharp, exposed staple tips can cause injury. Therefore, for your protection, please remove any exposed staple used in packing.

1. Two people are required to safely assemble this product.
2. Be sure to check all hardware in case that small parts may come loose inside the carton during shipment.
3. Please do not over tighten screws or bolts.
4. Please unpack the box and place the contents on a flat, level and soft surface.

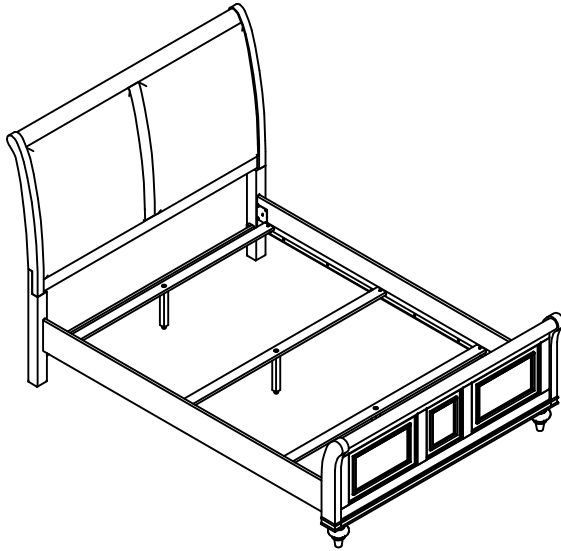

HARD WARE LIST			
PARTS	DESCRIPTION	SKETCH	Q"TY
A	ALLEN KEY		1PC
B	JCBC BOLT Ø5/16"×L45mm		8PCS
C	SPRING WASHER Ø5/16"Ø12mm		8PCS
D	FLAT WASHER Ø5/16"Ø19mm		8PCS
E	SCREWS Ø8*Ø4*L25mm		6PCS

① *1pc

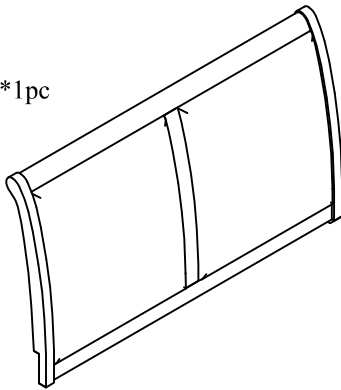

④ *1pc

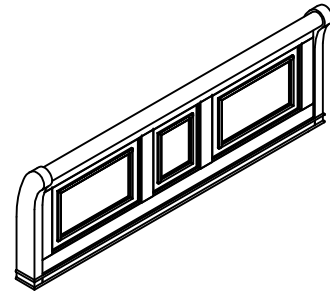

② *2pcs

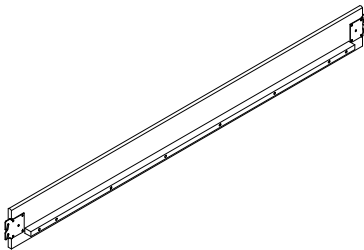

⑤ *1pc

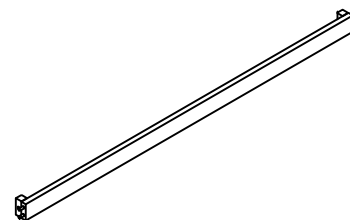

③ *3pcs

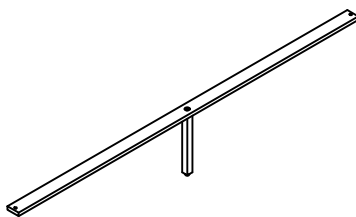

⑧ *2pcs

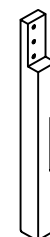

⑦ *1pc



⑥ *1pc

ASSEMBLY INSTRUCTION

DESCRIPTION: QUEEN BED

Caution: Please read instructions thoroughly before unpacking assembly parts. Sharp, exposed staple tips can cause injury. Therefore, for your protection, please remove any exposed staple used in packing.

1. Two people are required to safely assemble this product.

2. Be sure to check all hardware in case that small parts may come loose inside the carton during shipment.

3. Please do not over tighten screws or bolts.

4. Please unpack the box and place the contents on a flat, level and soft surface.

STEP 1

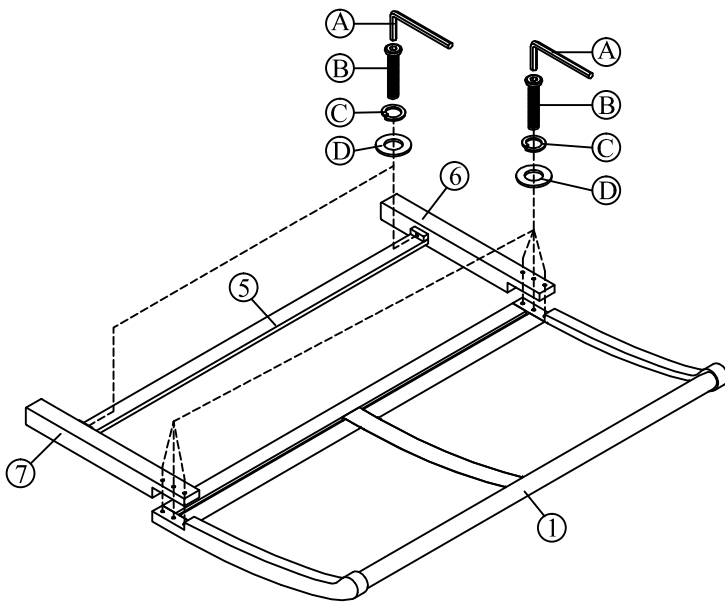

STEP 2

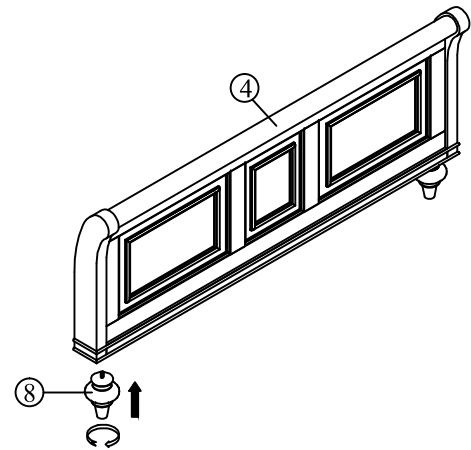

STEP 3

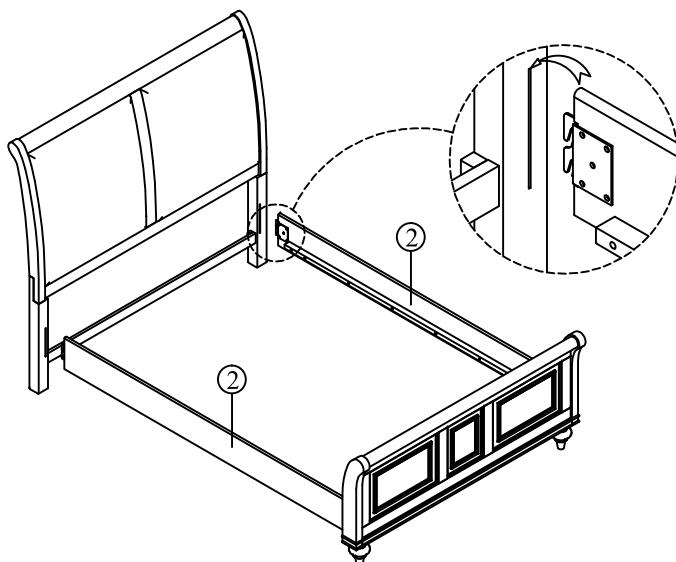

STEP 4

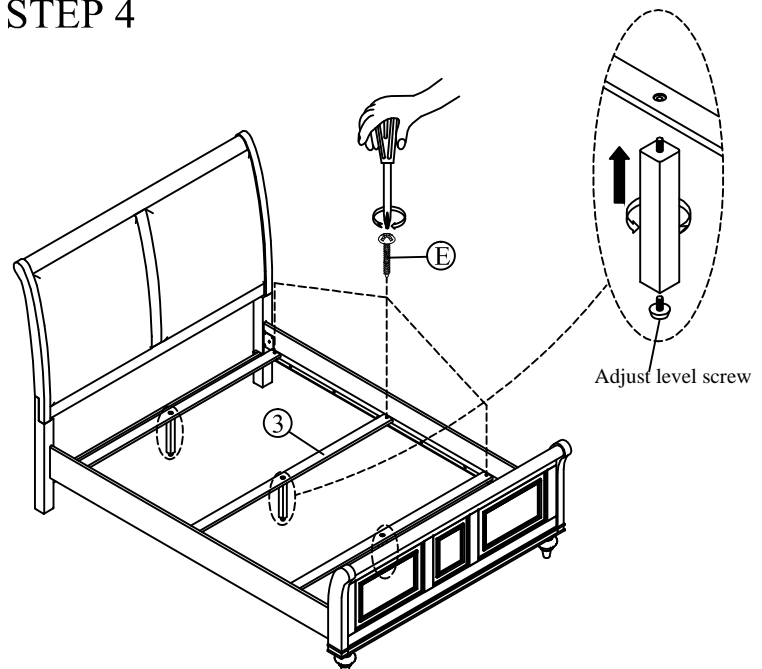

ASSEMBLY INSTRUCTION

DESCRIPTION: KING BED

Caution: Please read instructions thoroughly before unpacking assembly parts. Sharp, exposed staple tips can cause injury. Therefore, for your protection, please remove any exposed staple used in packing.

1. Two people are required to safely assemble this product.
2. Be sure to check all hardware in case that small parts may come loose inside the carton during shipment.
3. Please do not over tighten screws or bolts.
4. Please unpack the box and place the contents on a flat, level and soft surface.

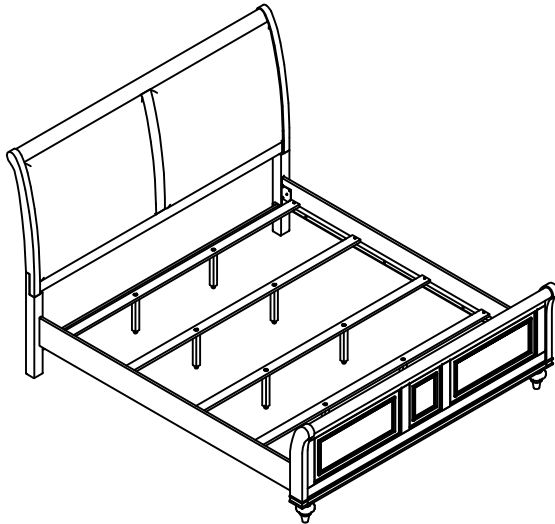

HARD WARE LIST			
PARTS	DESCRIPTION	SKETCH	Q"TY
A	ALLEN KEY		1PC
B	JCBC BOLT Ø5/16"×L45mm		8PCS
C	SPRING WASHER Ø5/16"Ø12mm		8PCS
D	FLAT WASHER Ø5/16"Ø19mm		8PCS
E	SCREWS Ø8*Ø4*L25mm		8PCS

① *1pc

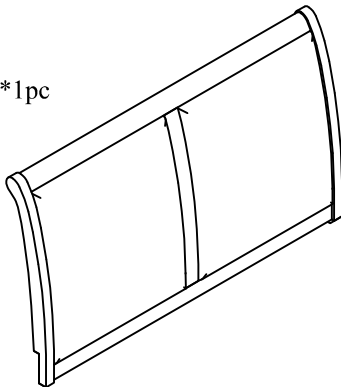

④ *1pc

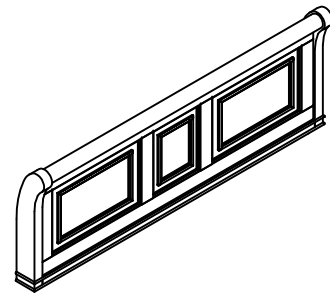

② *2pcs

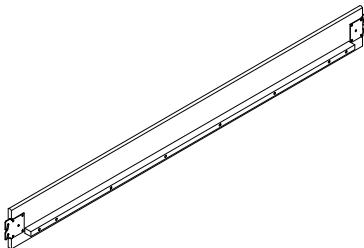

⑤ *1pc

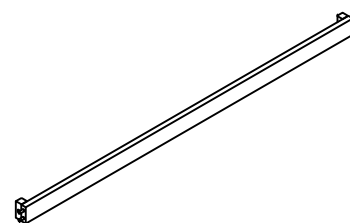

③ *4pcs

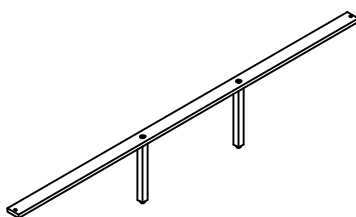

⑧ *2pcs

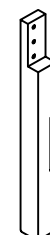

⑦ *1pc



⑥ *1pc

ASSEMBLY INSTRUCTION

DESCRIPTION: KING BED

Caution: Please read instructions thoroughly before unpacking assembly parts. Sharp, exposed staple tips can cause injury. Therefore, for your protection, please remove any exposed staple used in packing.

1. Two people are required to safely assemble this product.

2. Be sure to check all hardware in case that small parts may come loose inside the carton during shipment.

3. Please do not over tighten screws or bolts.

4. Please unpack the box and place the contents on a flat, level and soft surface.

STEP 1

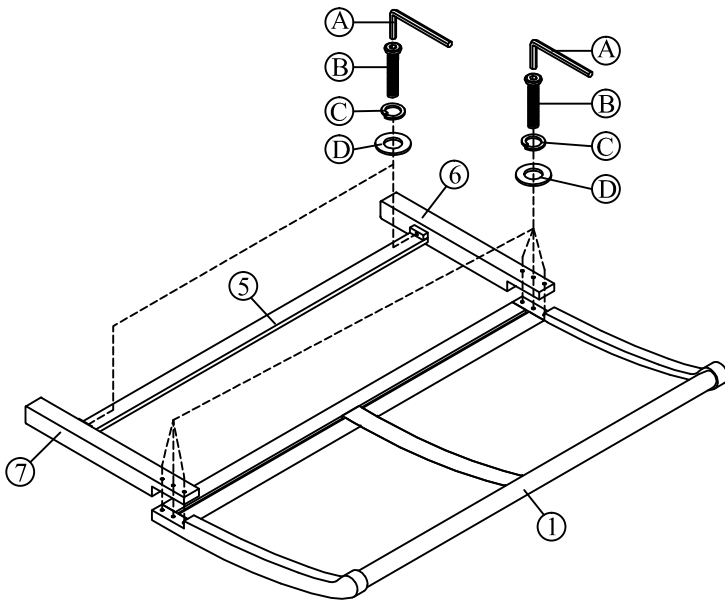

STEP 2

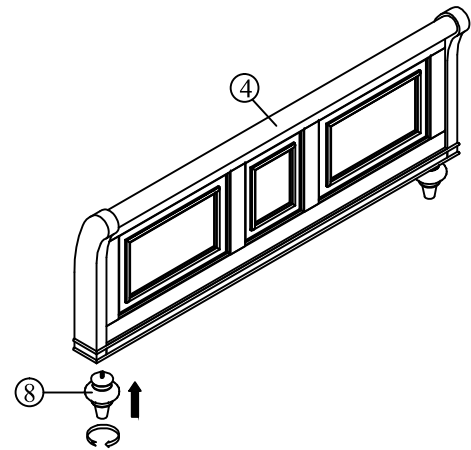

STEP 3

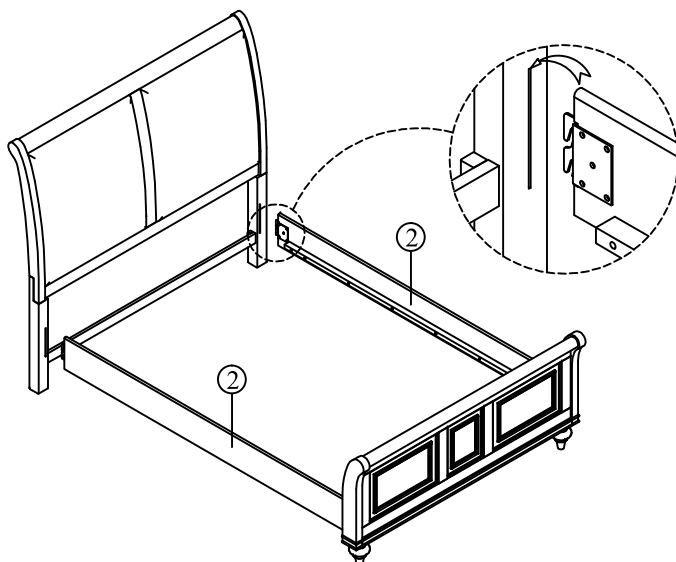

STEP 4

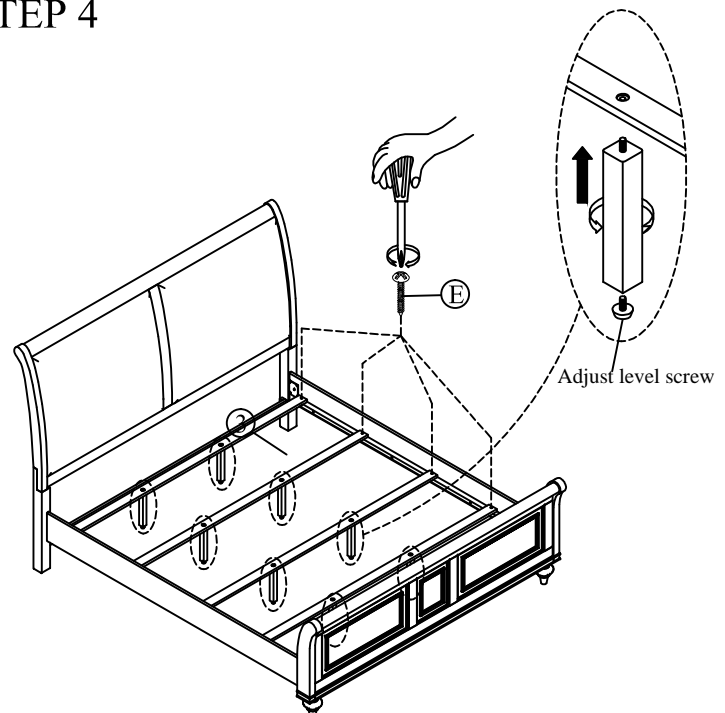

ASSEMBLY INSTRUCTION

DESCRIPTION: CAL KING BED

Caution: Please read instructions thoroughly before unpacking assembly parts. Sharp, exposed staple tips can cause injury. Therefore, for your protection, please remove any exposed staple used in packing.

1. Two people are required to safely assemble this product.
2. Be sure to check all hardware in case that small parts may come loose inside the carton during shipment.
3. Please do not over tighten screws or bolts.
4. Please unpack the box and place the contents on a flat, level and soft surface.

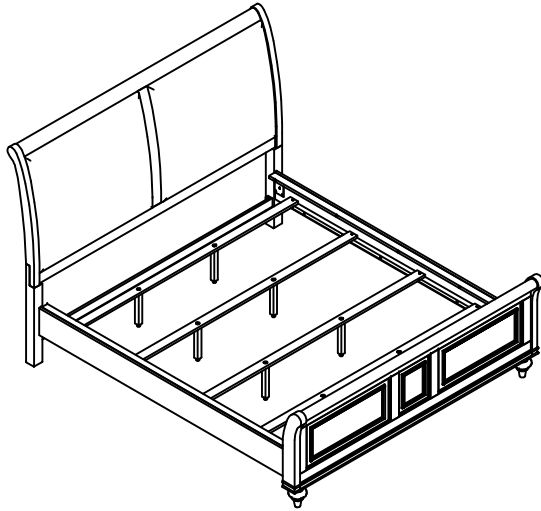

HARD WARE LIST			
PARTS	DESCRIPTION	SKETCH	Q"TY
A	ALLEN KEY		1PC
B	JCBC BOLT Ø5/16" * L45mm		8PCS
C	SPRING WASHER Ø5/16" * Ø12mm		8PCS
D	FLAT WASHER Ø5/16" * Ø19mm		8PCS
E	SCREWS Ø8 * Ø4 * L25mm		8PCS
F	JCBC BOLT Ø1/4" * L35mm		10PCS

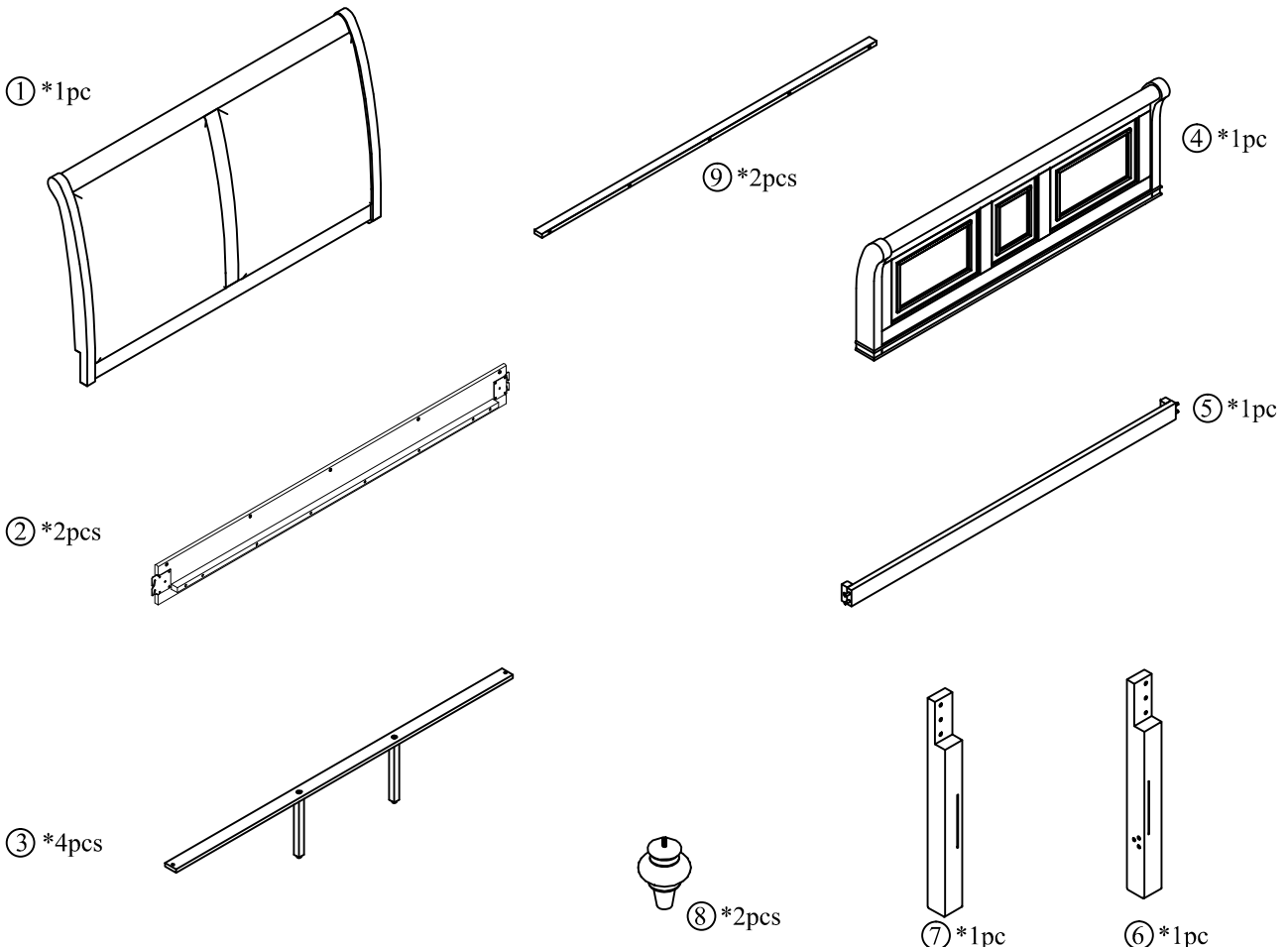

ASSEMBLY INSTRUCTION

DESCRIPTION: CAL KING BED

Caution: Please read instructions thoroughly before unpacking assembly parts. Sharp, exposed staple tips can cause injury. Therefore, for your protection, please remove any exposed staple used in packing.

1. Two people are required to safely assemble this product.
2. Be sure to check all hardware in case that small parts may come loose inside the carton during shipment.
3. Please do not over tighten screws or bolts.
4. Please unpack the box and place the contents on a flat, level and soft surface.

STEP 1

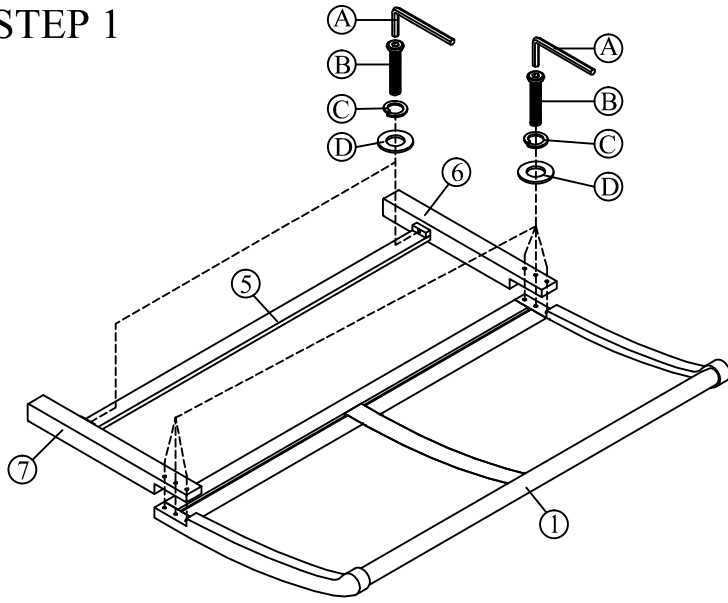

STEP 2

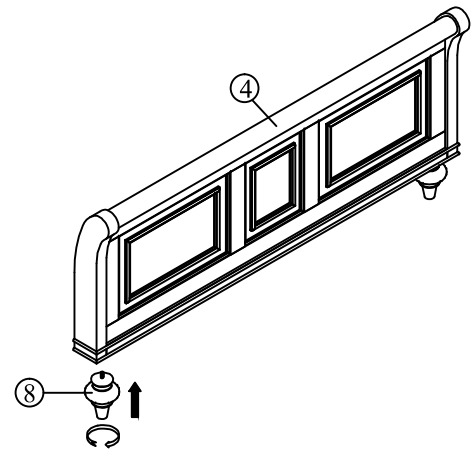

STEP 3

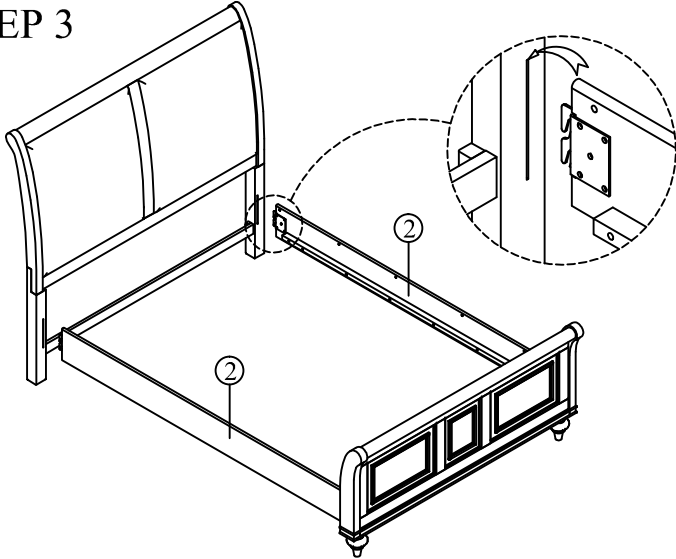

STEP 4

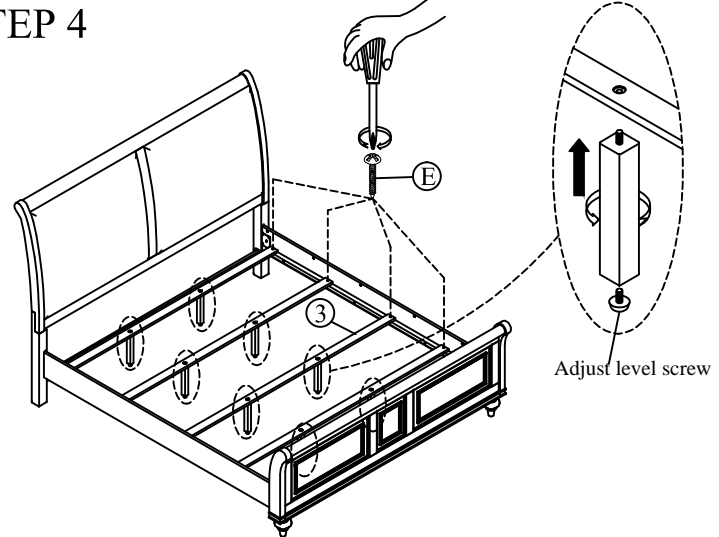

STEP 5

