

# Assembly Manual

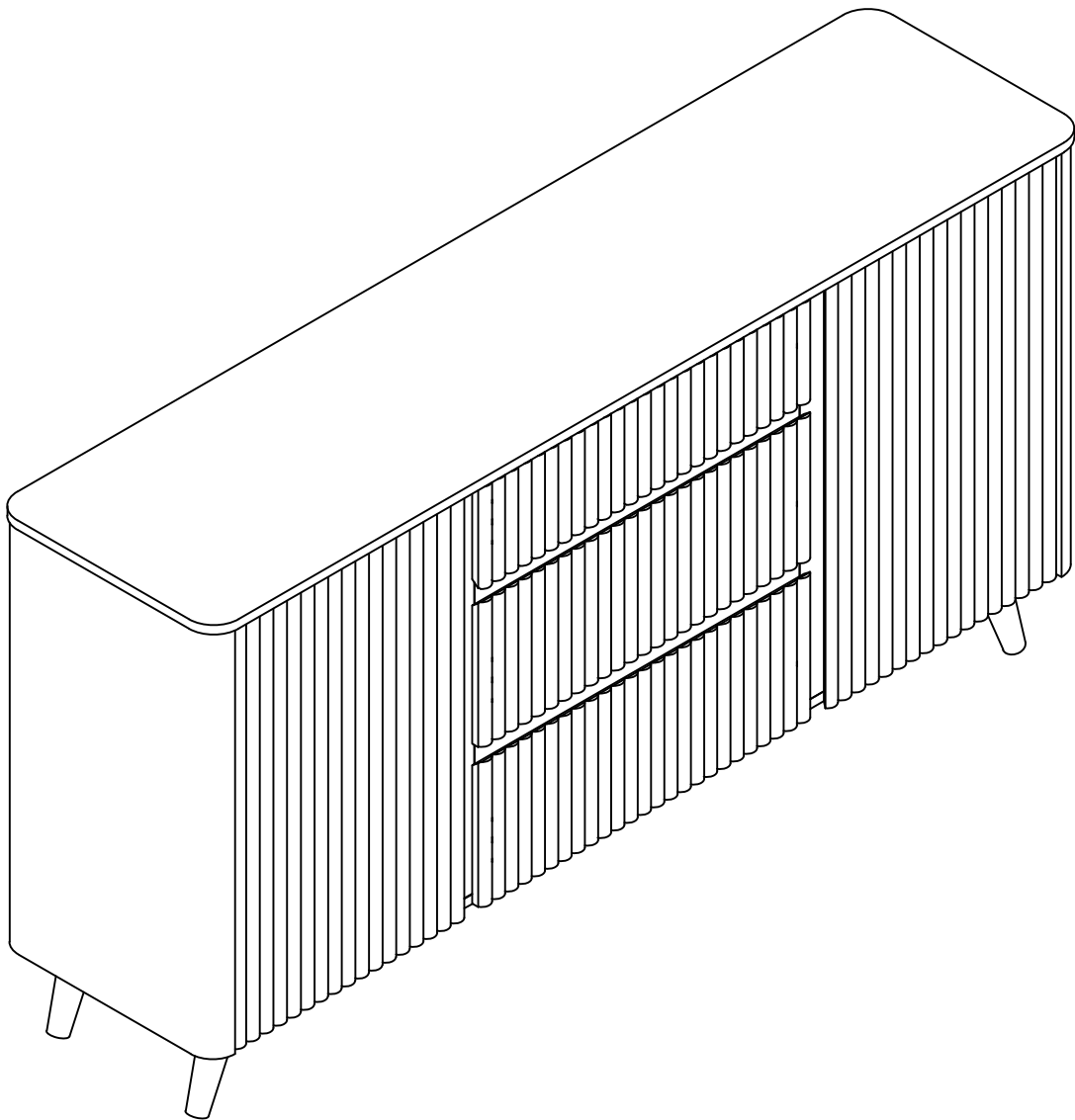

For Residential Use Only

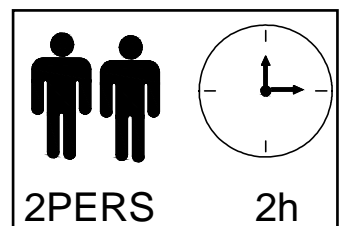



[EN]

**Warning:** Please read instructions fully before starting assembly. Check you have all the components and tools listed on pages.

**Warning:** Please place all parts on a flat surface. Place a soft blanket or similar underneath to protect against scratches or stains. Avoid dragging or sliding components across the floor.

**Warning:** Regularly check all fittings and fastenings to ensure they are secure and to prevent accidents. If any parts are missing, broken, damaged, or worn, discontinue use of the product until repairs have been made using factory authorized parts.

**Warning:** Do not allow children to climb on the furniture as this may result in tipping and serious personal injury. Assemble the furniture away from the reach of children.

**Warning:** Do not place furniture close to fire sources or high-temperature objects to avoid the risk of fire

**Warning:** Clean furniture with a damp cloth or alcohol, avoid using cleaning agents containing corrosive chemicals.

**Warning:** This product is equipped with an anti-tilt device. Please be sure to install this device to prevent unnecessary injuries caused by tipping.

[DE]

**Warnung:** Lesen Sie die Anleitung vor dem Zusammenbau bitte vollständig durch. Überprüfen Sie, ob Sie alle auf den Seiten aufgeführten Komponenten und Werkzeuge haben.

**Warnung:** Legen Sie alle Teile auf eine ebene Fläche. Legen Sie eine weiche Decke oder Ähnliches darunter, um sie vor Kratzern oder Flecken zu schützen. Vermeiden Sie es, Komponenten über den Boden zu ziehen oder zu schieben.

**Warnung:** Überprüfen Sie regelmäßig alle Beschläge und Befestigungen, um sicherzustellen, dass sie sicher sind und um Unfälle zu vermeiden. Wenn Teile fehlen, kaputt, beschädigt oder abgenutzt sind, verwenden Sie das Produkt nicht weiter, bis es mit vom Hersteller autorisierten Teilen repariert wurde.

**Warnung:** Lassen Sie Kinder nicht auf die Möbel klettern, da dies zum Umkippen und zu schweren Verletzungen führen kann. Bauen Sie die Möbel außerhalb der Reichweite von Kindern zusammen.

**Warnung:** Stellen Sie die Möbel nicht in die Nähe von Feuerquellen oder heißen Gegenständen, um Brandgefahr zu vermeiden.

**Warnung:** Reinigen Sie die Möbel mit einem feuchten Tuch oder Alkohol. Verwenden Sie keine Reinigungsmittel mit ätzenden Chemikalien.

**Warnung:** Dieses Produkt ist mit einer Kippschutzvorrichtung ausgestattet. Bitte installieren Sie diese Vorrichtung unbedingt, um unnötige Verletzungen durch Umkippen zu vermeiden.

[FR]

**Avertissement :** Veuillez lire entièrement les instructions avant de commencer l'assemblage. Vérifiez que vous disposez de tous les composants et outils répertoriés sur les pages.

**Avertissement :** Veuillez placer toutes les pièces sur une surface plane. Placez une couverture douce ou similaire en dessous pour les protéger des rayures ou des taches. Évitez de faire glisser les composants sur le sol.

**Avertissement :** Vérifiez régulièrement tous les raccords et fixations pour vous assurer qu'ils sont bien fixés et pour éviter les accidents. Si des pièces manquent, sont cassées, endommagées ou usées, cessez d'utiliser le produit jusqu'à ce que des réparations aient été effectuées à l'aide de pièces autorisées par l'usine.

**Avertissement :** Ne laissez pas les enfants grimper sur les meubles car cela pourrait entraîner un basculement et des blessures graves. Assemblez les meubles hors de portée des enfants.

**Avertissement :** Ne placez pas les meubles à proximité de sources de feu ou d'objets à haute température pour

éviter tout risque d'incendie.

**Avertissement** : Nettoyez les meubles avec un chiffon humide ou de l'alcool, évitez d'utiliser des produits de nettoyage contenant des produits chimiques corrosifs.

**Avertissement** : Ce produit est équipé d'un dispositif anti-basculement. Assurez-vous d'installer ce dispositif pour éviter les blessures inutiles causées par un basculement.

[IT]

**Attenzione**: leggere attentamente le istruzioni prima di iniziare il montaggio. Verificare di avere tutti i componenti e gli strumenti elencati nelle pagine.

**Attenzione**: posizionare tutte le parti su una superficie piana. Posizionare una coperta morbida o simile sotto per proteggere da graffi o macchie. Evitare di trascinare o far scivolare i componenti sul pavimento.

**Attenzione**: controllare regolarmente tutti i raccordi e i dispositivi di fissaggio per assicurarsi che siano sicuri e per prevenire incidenti. Se alcune parti sono mancanti, rotte, danneggiate o usurate, interrompere l'uso del prodotto fino a quando non siano state eseguite le riparazioni utilizzando parti autorizzate dalla fabbrica.

**Attenzione**: non consentire ai bambini di arrampicarsi sui mobili poiché ciò potrebbe causare ribaltamenti e gravi lesioni personali. Montare i mobili lontano dalla portata dei bambini.

**Attenzione**: non posizionare i mobili vicino a fonti di fuoco o oggetti ad alta temperatura per evitare il rischio di incendio

**Attenzione**: pulire i mobili con un panno umido o alcol, evitare di utilizzare detergenti contenenti sostanze chimiche corrosive.

**Attenzione**: questo prodotto è dotato di un dispositivo antiribaltamento. Assicurarsi di installare questo dispositivo per prevenire lesioni inutili causate dal ribaltamento.

[ES]

**Advertencia**: Lea las instrucciones completamente antes de comenzar el montaje. Compruebe que tiene todos los componentes y herramientas que se enumeran en las páginas.

**Advertencia**: Coloque todas las piezas sobre una superficie plana. Coloque una manta suave o algo similar debajo para protegerlas de rayones o manchas. Evite arrastrar o deslizar los componentes por el piso.

**Advertencia**: Verifique regularmente todos los accesorios y fijaciones para asegurarse de que estén seguros y evitar accidentes. Si falta alguna pieza, está rota, dañada o desgastada, deje de usar el producto hasta que se hayan realizado las reparaciones con piezas autorizadas de fábrica.

**Advertencia**: No permita que los niños se suban a los muebles, ya que esto puede provocar que se vuelquen y lesiones personales graves. Monte los muebles fuera del alcance de los niños.

**Advertencia**: No coloque los muebles cerca de fuentes de fuego u objetos de alta temperatura para evitar el riesgo de incendio.

**Advertencia**: Limpie los muebles con un paño húmedo o alcohol, evite usar agentes de limpieza que contengan químicos corrosivos.

**Advertencia**: Este producto está equipado con un dispositivo antivuelco. Asegúrese de instalar este dispositivo para evitar lesiones innecesarias causadas por vuelcos.



EN

**Warning**: The maximum load-bearing capacity of this furniture is: 30 kg, please do not overload!

DE

**Warnung**: Die maximale Belastbarkeit dieses Möbels beträgt: 30 kg, bitte nicht überlasten!

FR

**Avertissement** : La capacité de charge maximale de ce meuble est de : 30 kg, merci de ne pas surcharger !

IT

**Attenzione**: la capacità di carico massima di questo mobile è: 30 kg, non sovraccaricare!

ES

**Advertencia**: La capacidad máxima de carga de este mueble es: 30 kg, ¡no lo sobrecargue!



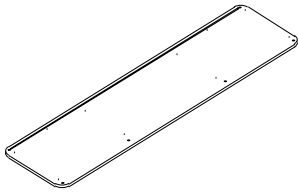

①×1

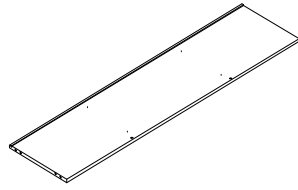

②×1

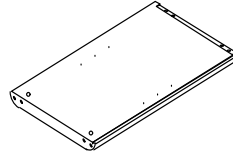

③×1

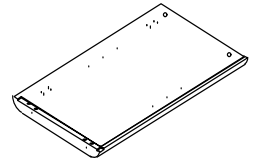

④×1

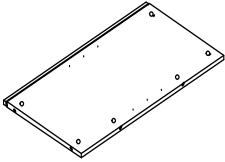

⑤×1

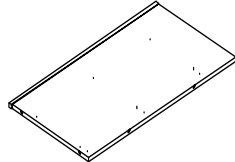

⑥×1

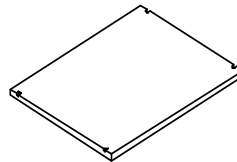

⑦×2

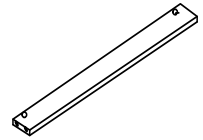

⑧×2

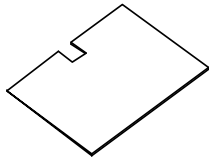

⑨×2

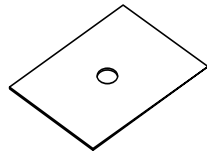

⑩×2

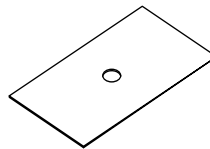

⑪×1

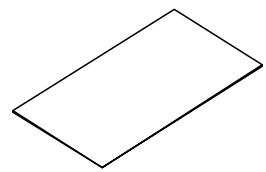

⑫×1

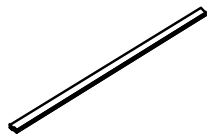

⑬×2

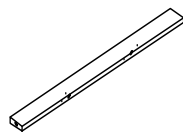

⑭×1

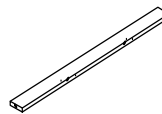

⑮×1

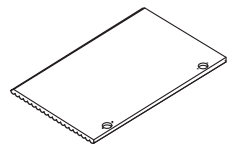

⑯×2

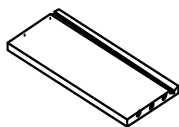

⑰×2

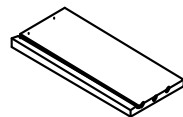

⑱×2

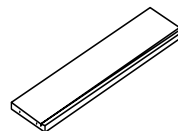

⑲×2

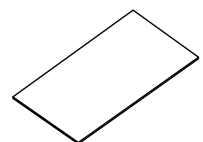

⑳×3

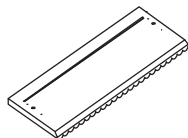

㉑×2

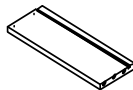

㉒×1

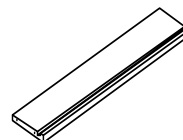

㉓×1

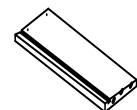

㉔×1

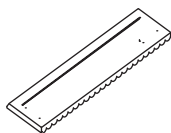

㉕×1



㉖×4











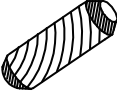
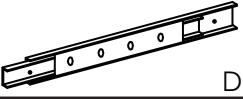
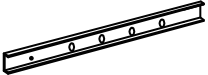

㉗×2

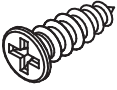

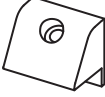
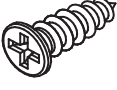
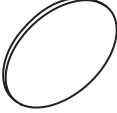
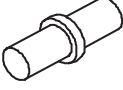
㉘×1

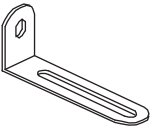
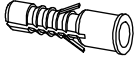
# Hardware List

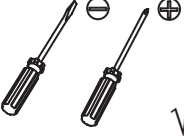
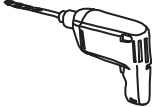
<p>Ax36</p> 	<p>Bx36</p> 	<p>Cx22</p>  <p>Ø10×30</p>	<p>Dx3</p>  <p>D1</p>  <p>D2</p>
<p>Ex12</p>  <p>Ø3.5×35</p>	<p>Fx66</p>  <p>Ø3.5×14</p>	<p>Gx26</p>  <p>Ø4×14</p>	<p>Hx8</p> 
<p>Ix8</p>  <p>Ø3×16</p>	<p>Jx36</p> 	<p>Kx8</p> 	<p>Lx4</p>  <p>Ø4×40</p>
<p>Mx2</p> 	<p>Nx2</p> 	<p>Ox2</p>  <p>Ø4×40</p>	<p>Tool Required Not Provided</p> 
<p>Use Power Tools with Caution</p>  <p>X</p>			

Please read through the instructions below to familiarize yourself with the parts and steps before assembly.

**Use power tools with caution. You can cause cracking or damage to the material and easily strip the hardware. If you choose to use a power tool, your product will no longer be covered warranty.**

1. Screw Cam Bolts A into Part 14 and Part 15. Insert Dowels C into Part 14 and Part 15.

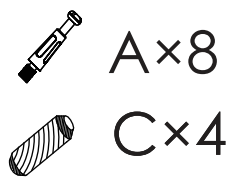
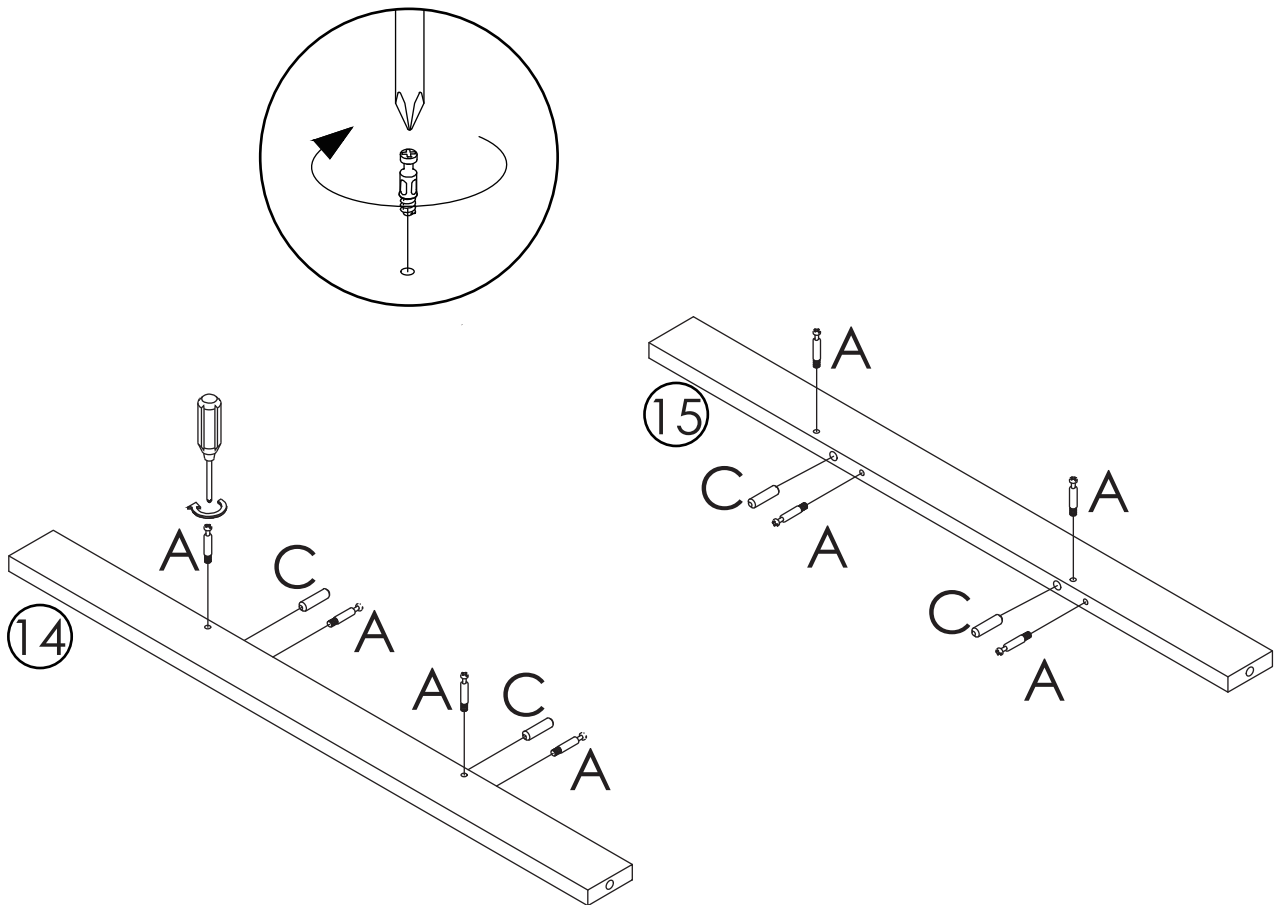

2. Attach Part 5 to Part 14, Attach Part 6 to Part 15. Secure with Cam Locks B. Please pay attention to the arrow direction on Cam Locks B.

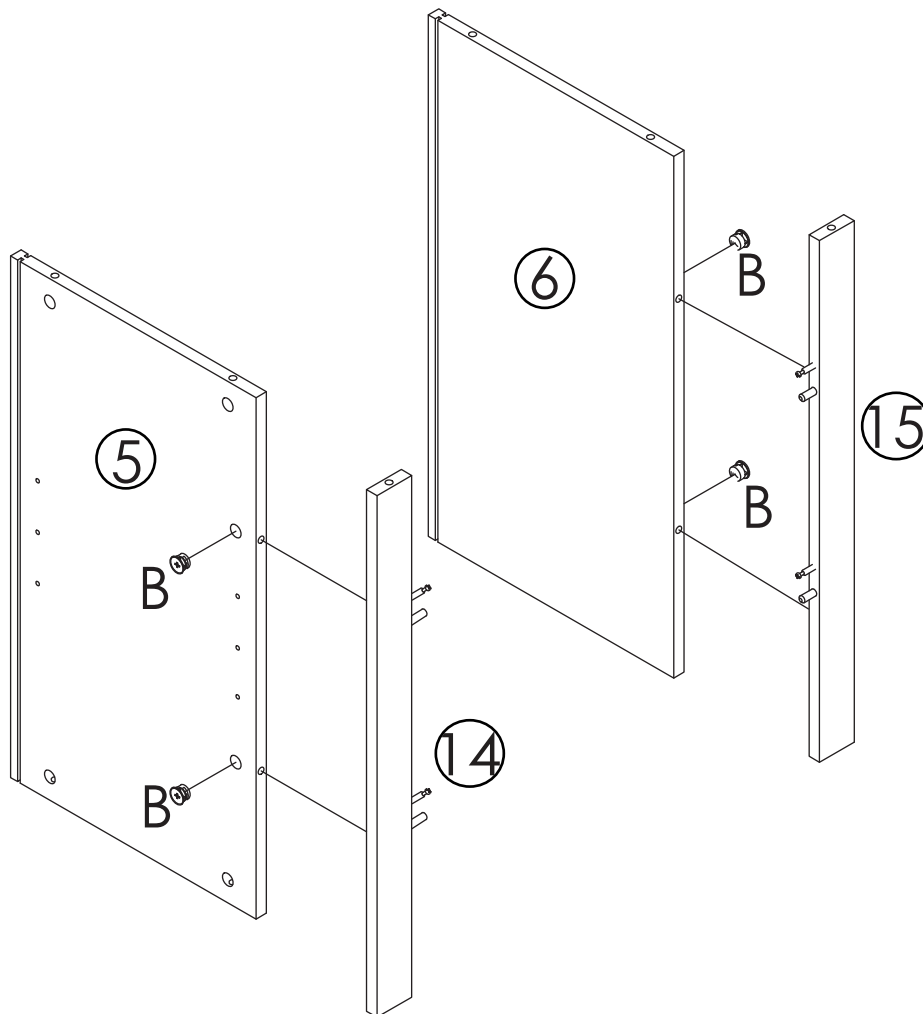

B×4

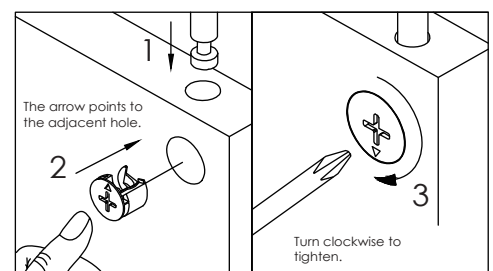

3. Detach D1 from D2.

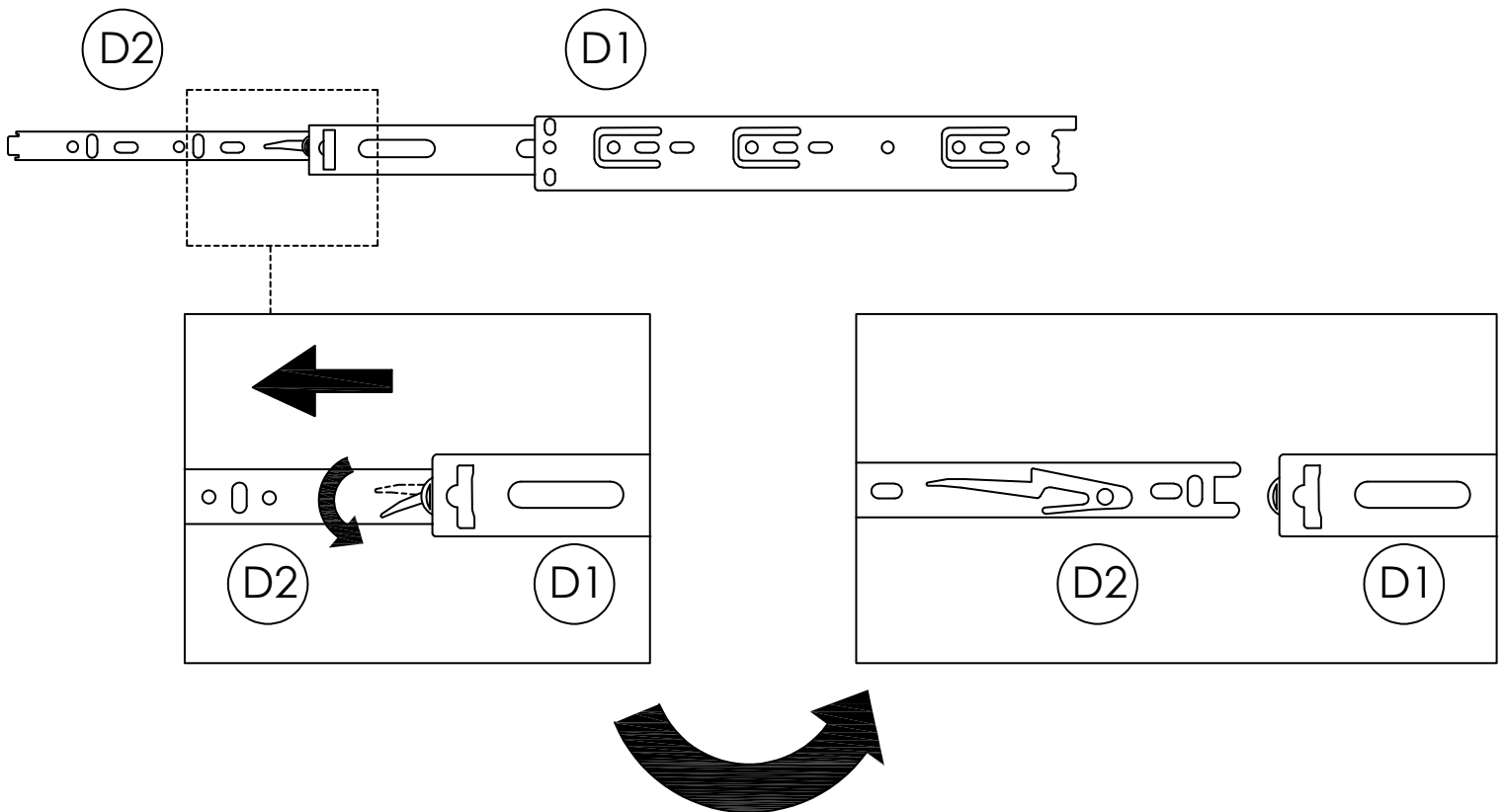

4. Attach D1 to Part 5 using Screws F. Please pay attention to the Screw Point as indicated below.

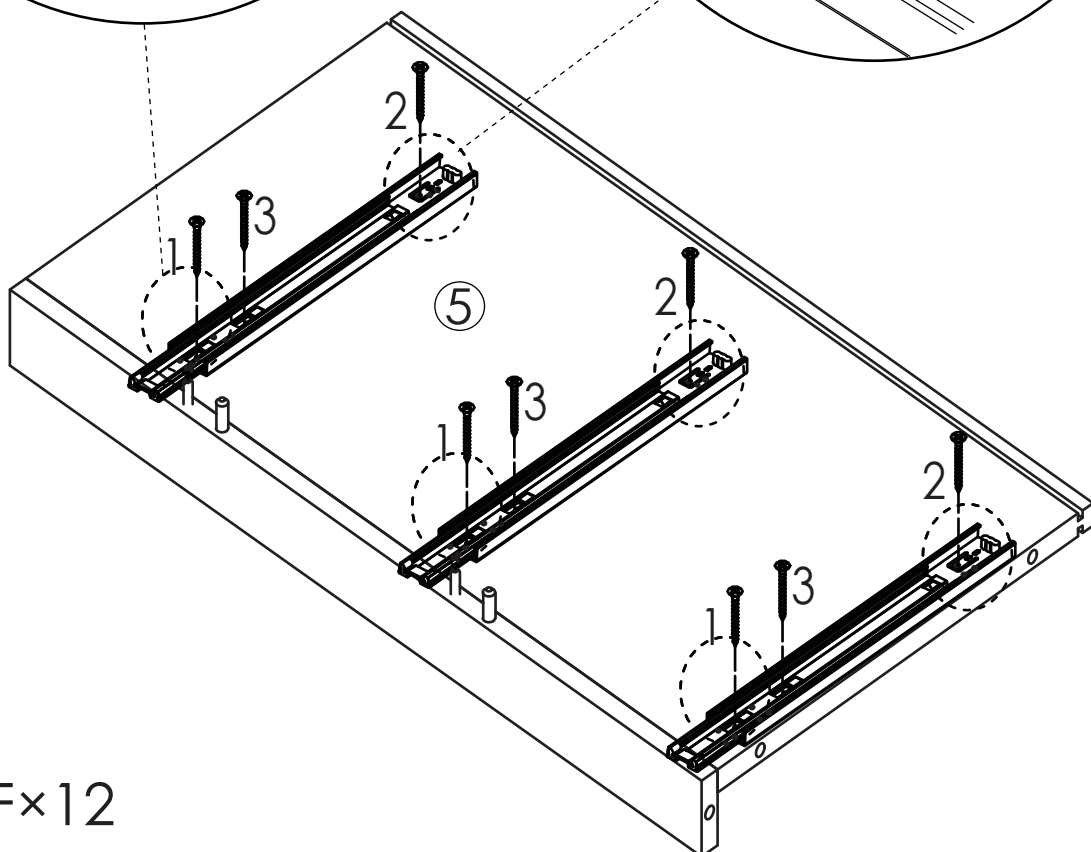
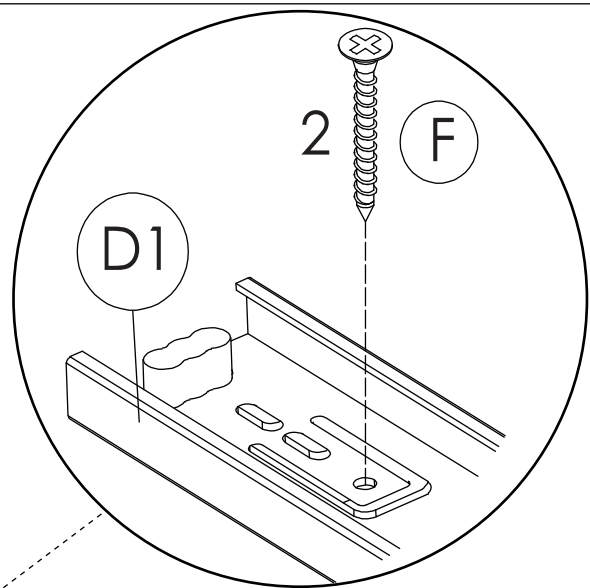
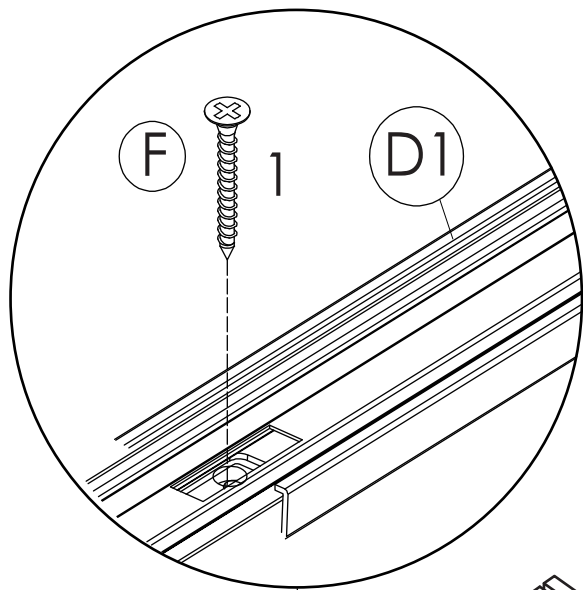
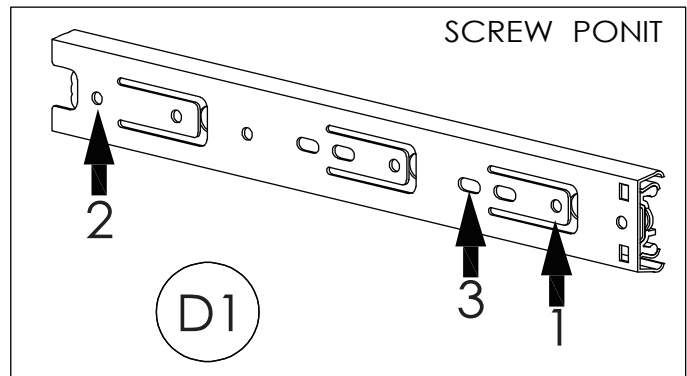

5. Attach D1 to Part 6 using Screws F. Please pay attention to the Screw Point as indicated below.

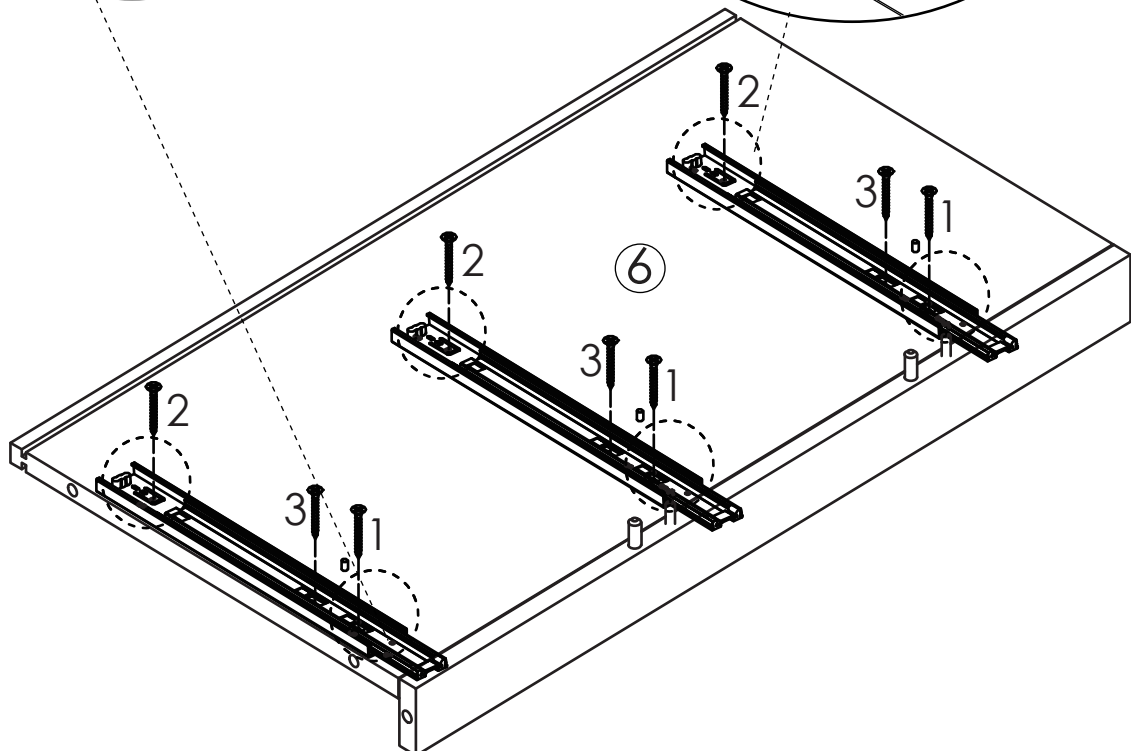
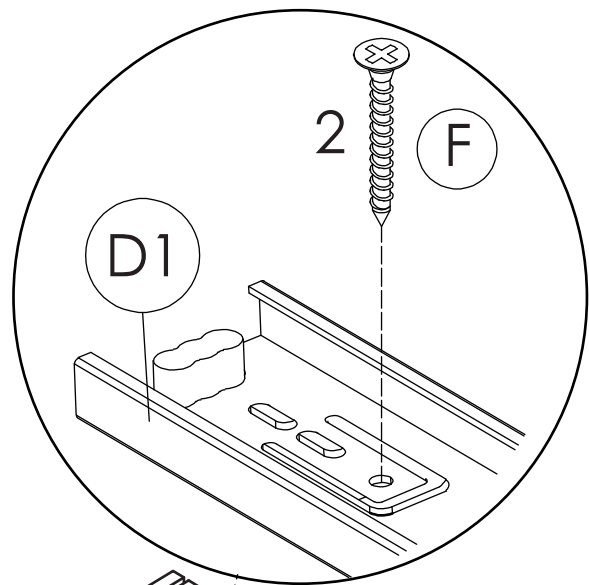
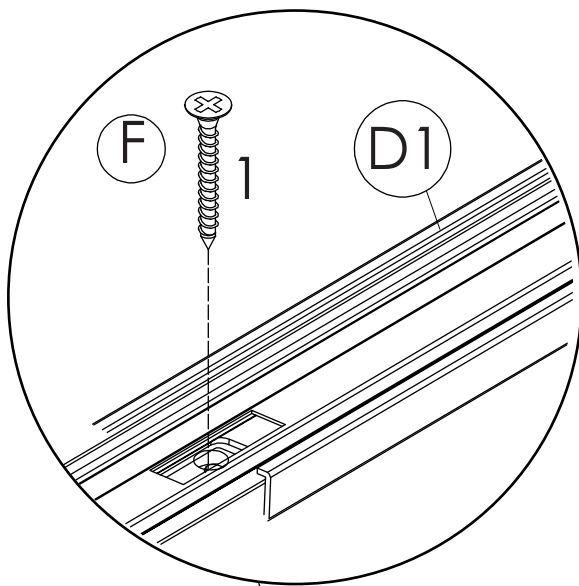
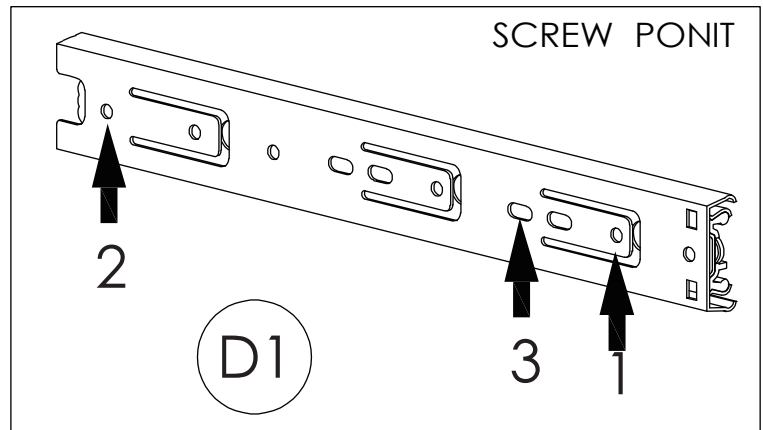

6. Attach Parts 8 to Part 14 and Part 15. Secure with Cam Locks B. Please pay attention to the arrow direction on Cam Locks B.

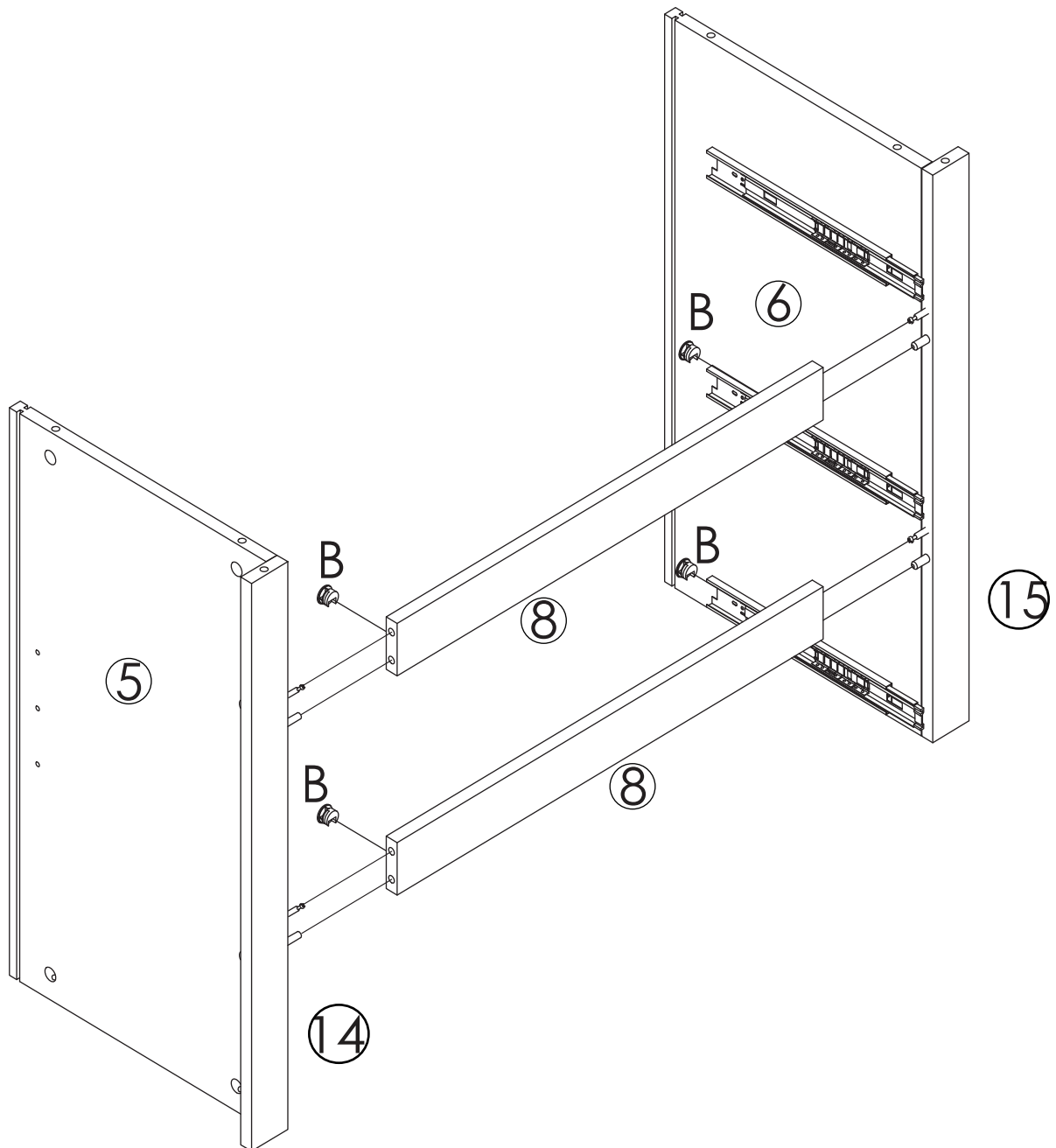

 B×4

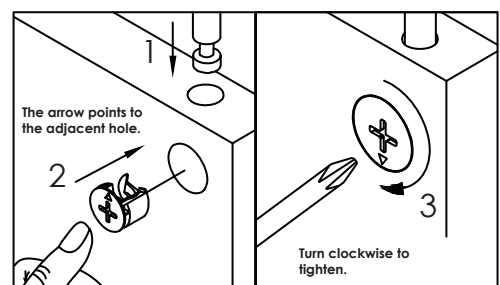

7.Screw Cam Bolts A into Part 2. Insert Dowels C into Part 2.

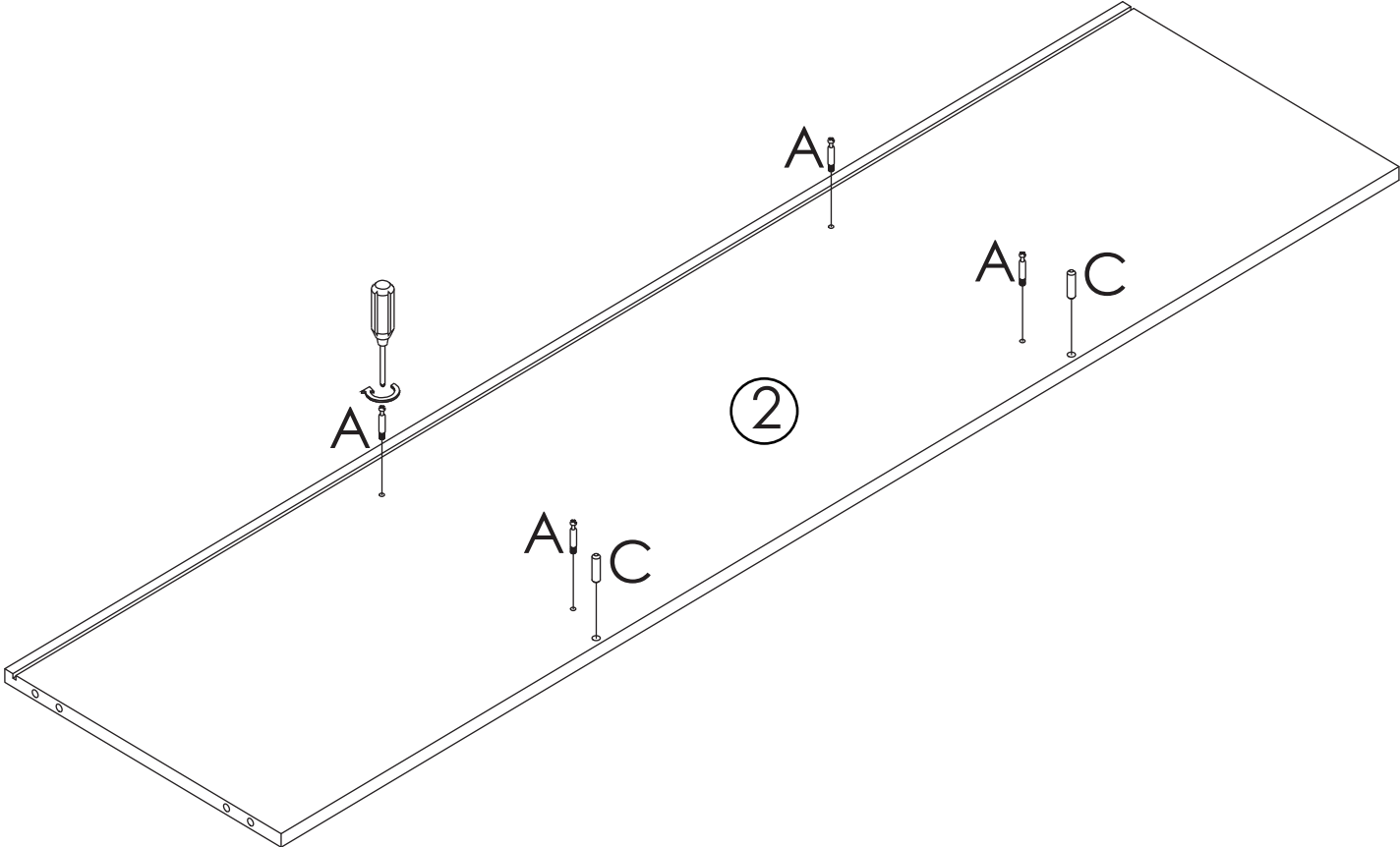

 A×4

 C×2

8. Attach Part 2 to the assembled part of the previous step. Secure with Cam Locks B. Please pay attention to the arrow direction on Cam Locks B.

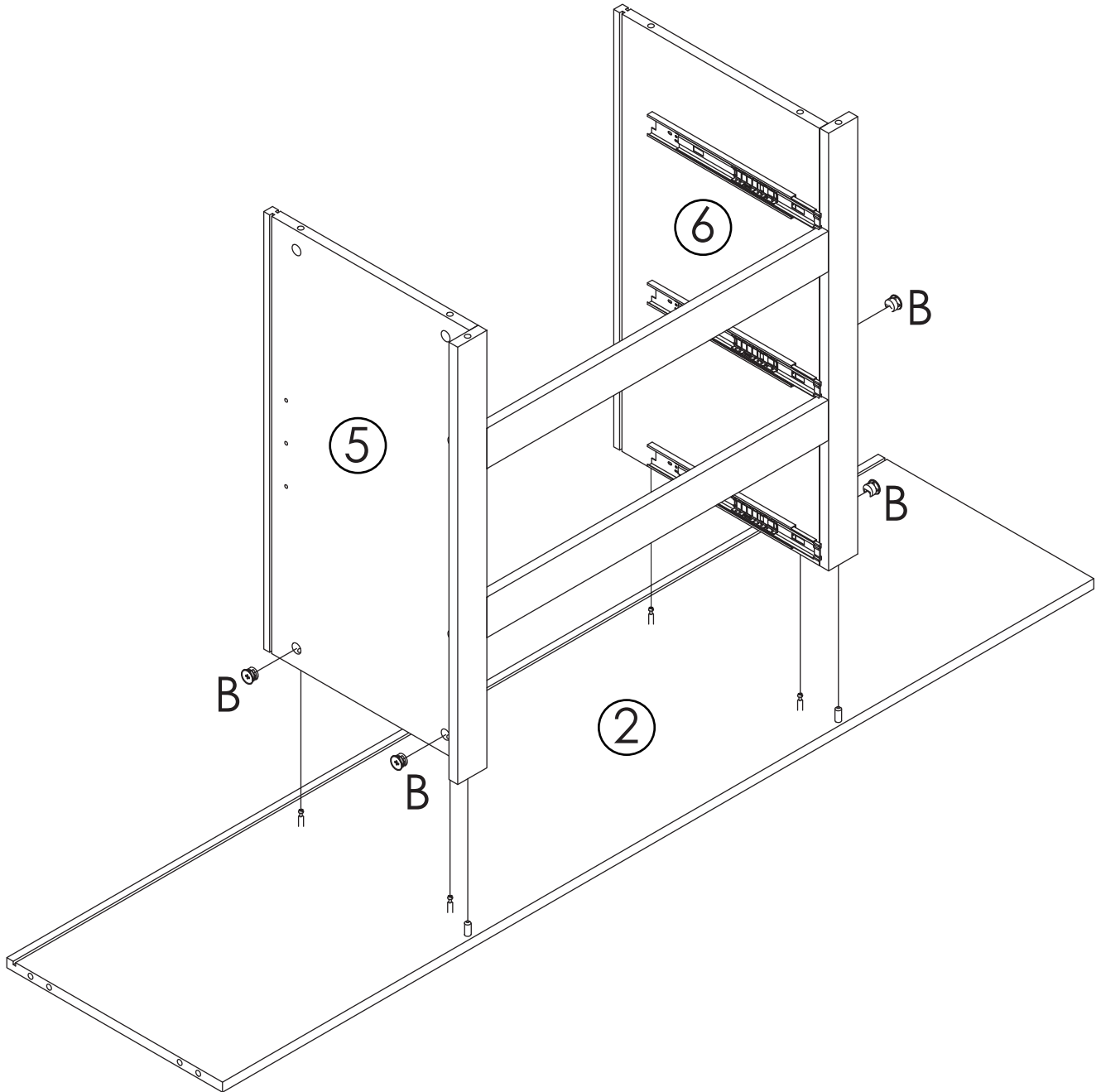

 B×4

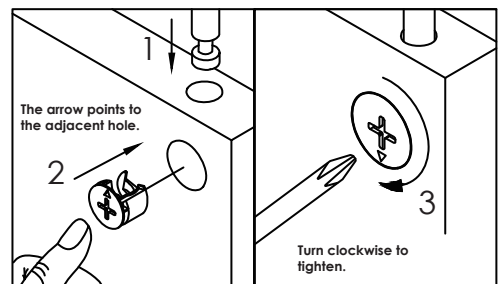

9. Screw Cam Bolts A into Part 3 and Part 4. Insert Dowels C into Part 3 and Part 4.

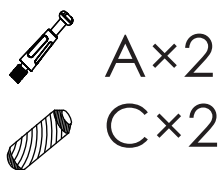
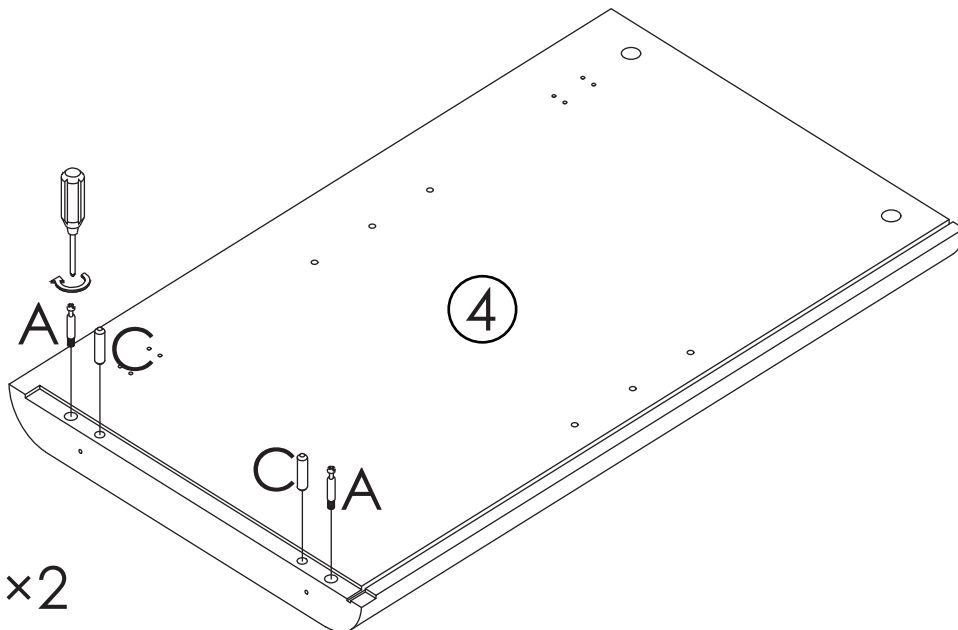
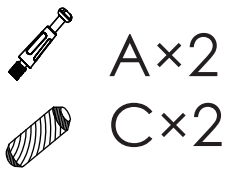
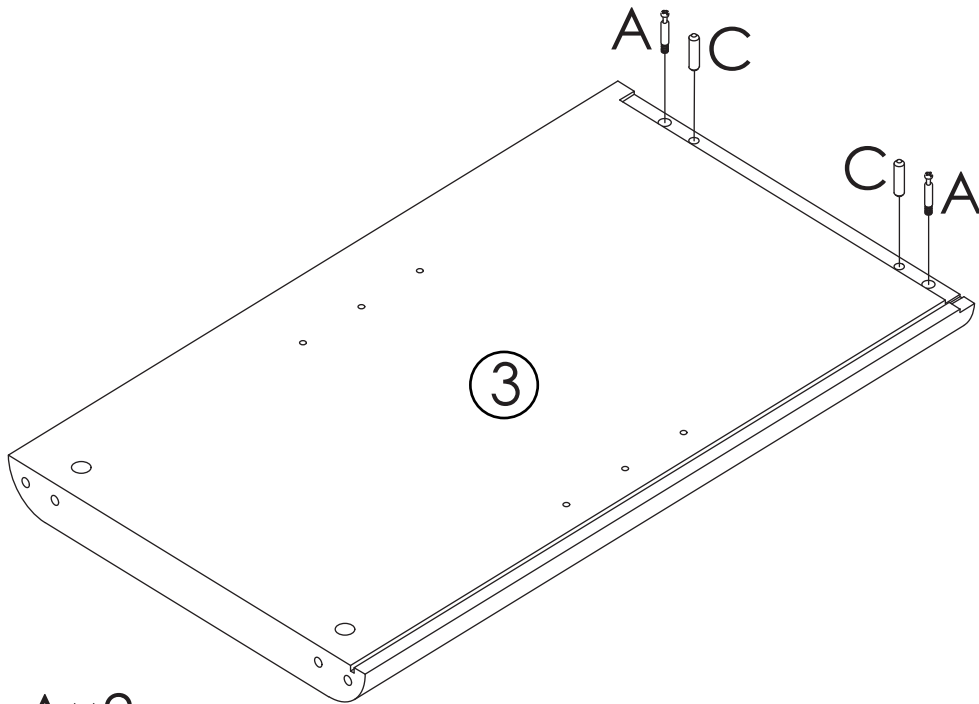

10. Attach Part 3 and Part 4 to Part 2. Secure with Cam Locks B. Please pay attention to the arrow direction on Cam Locks B.

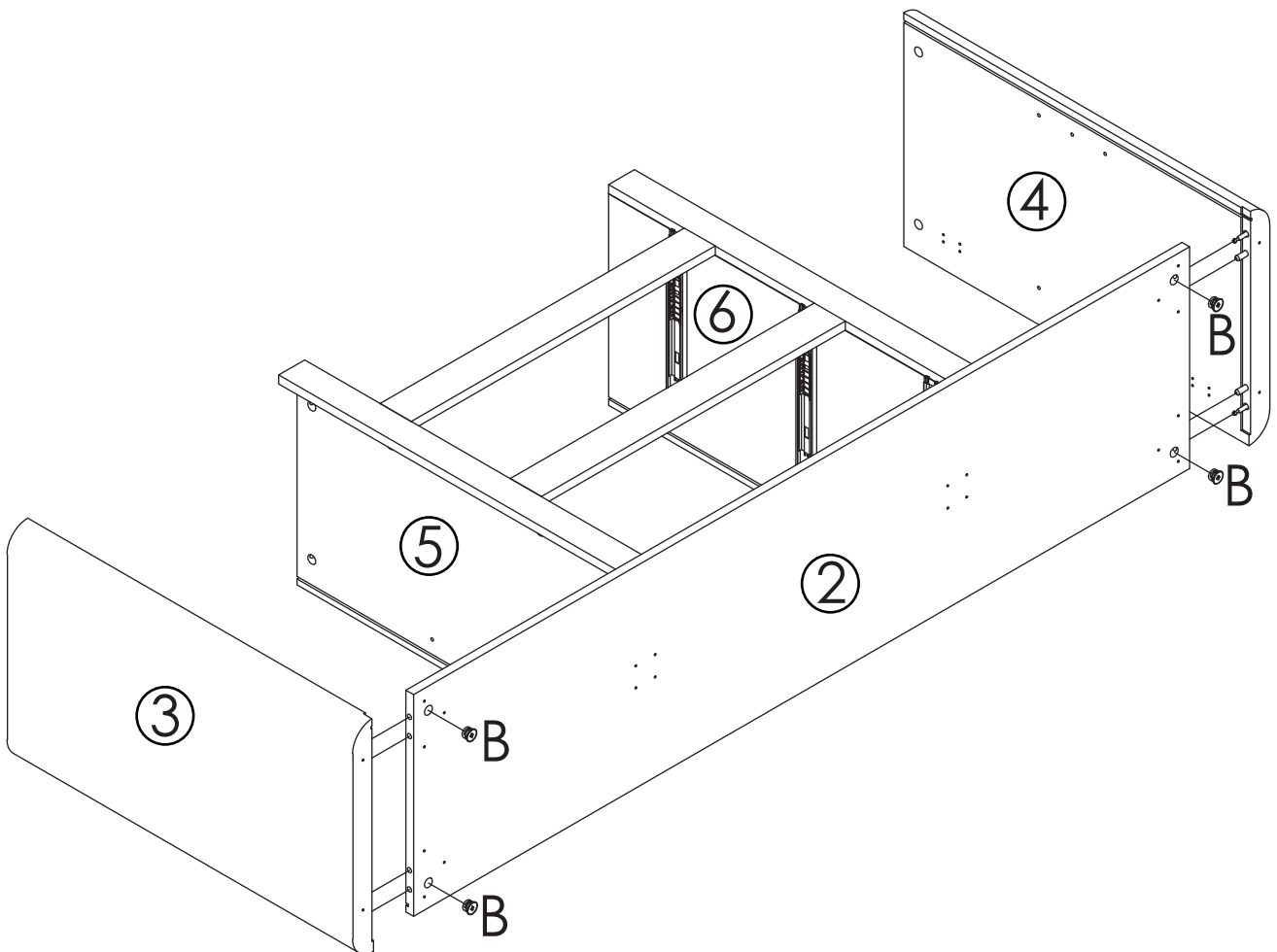

 B×4

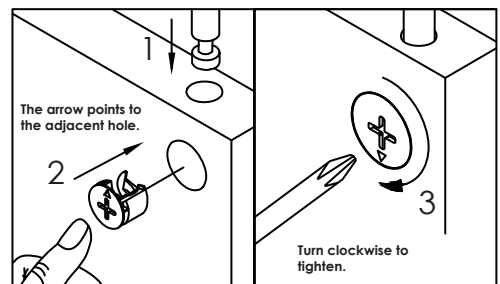

11. Insert Part 9, 13, 10 and Part 11, 28, 12. Use the grooves as your guides to slide into place.

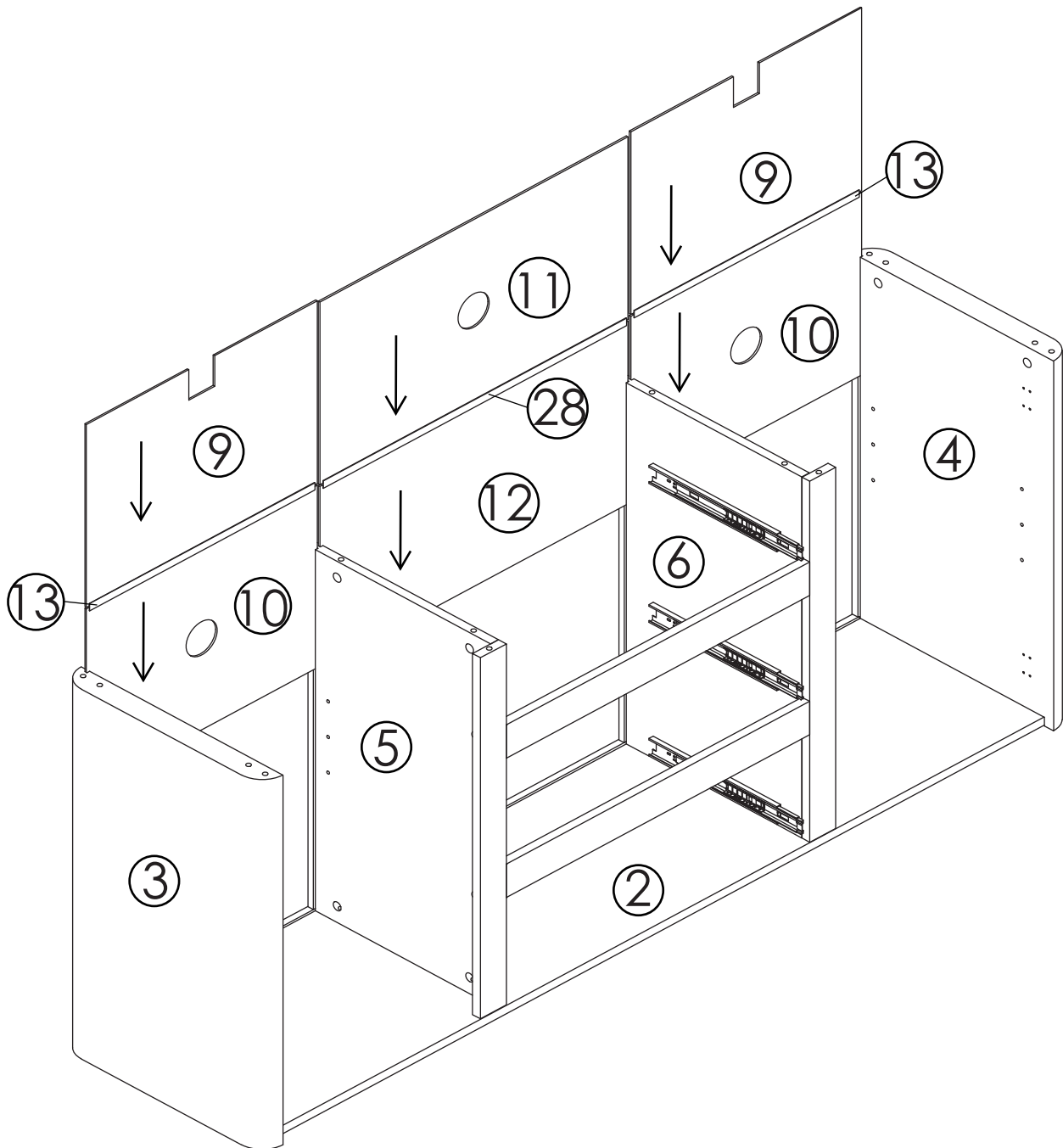

12.Screw Cam Bolts A into Part 1. Insert Dowels C into Part 1. Attach Metal Parts M into Part 1.

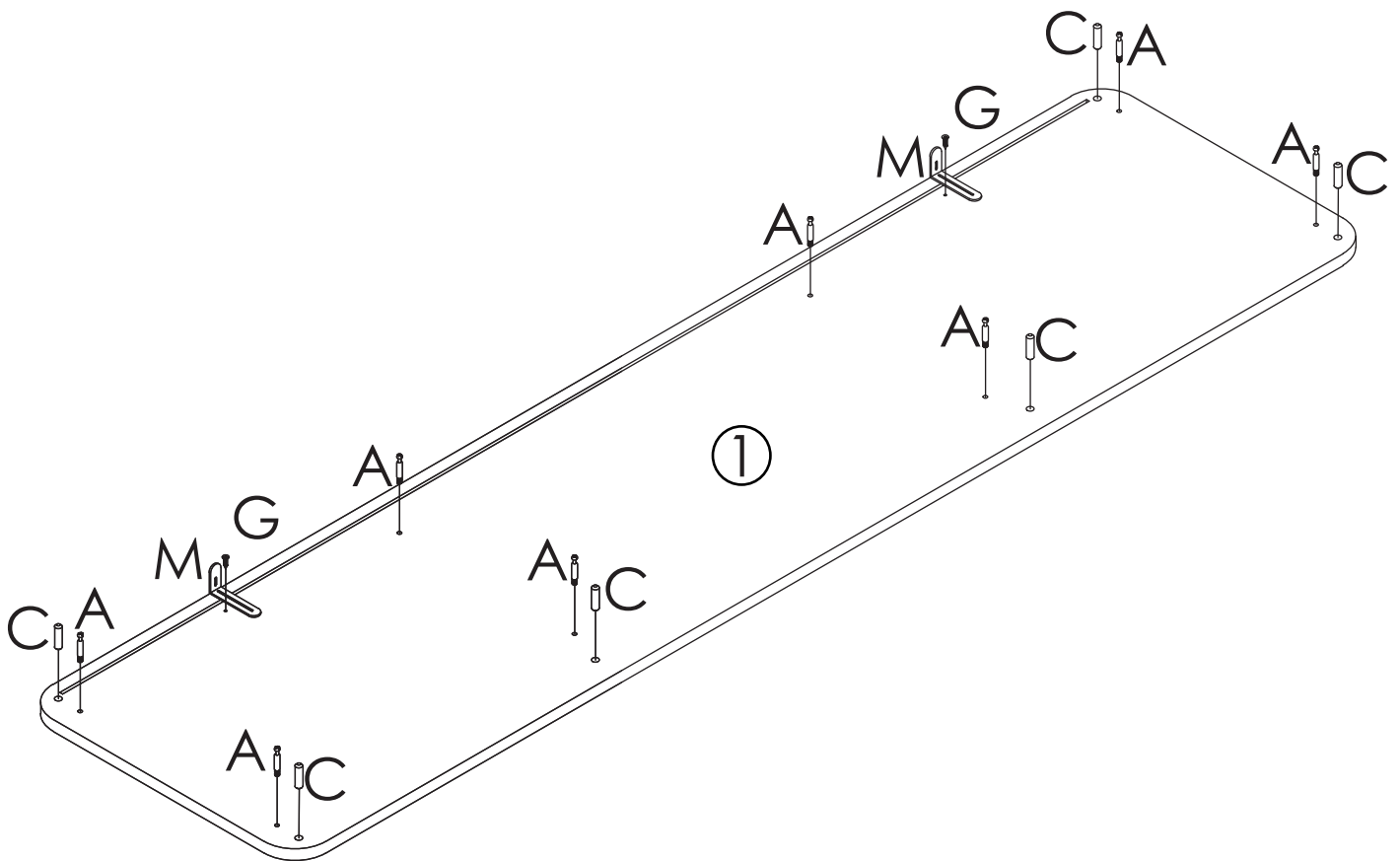

13. Attach Part 1 to the assembled part of the previous step. Secure with Cam Locks B. Please pay attention to the arrow direction on Cam Locks B.

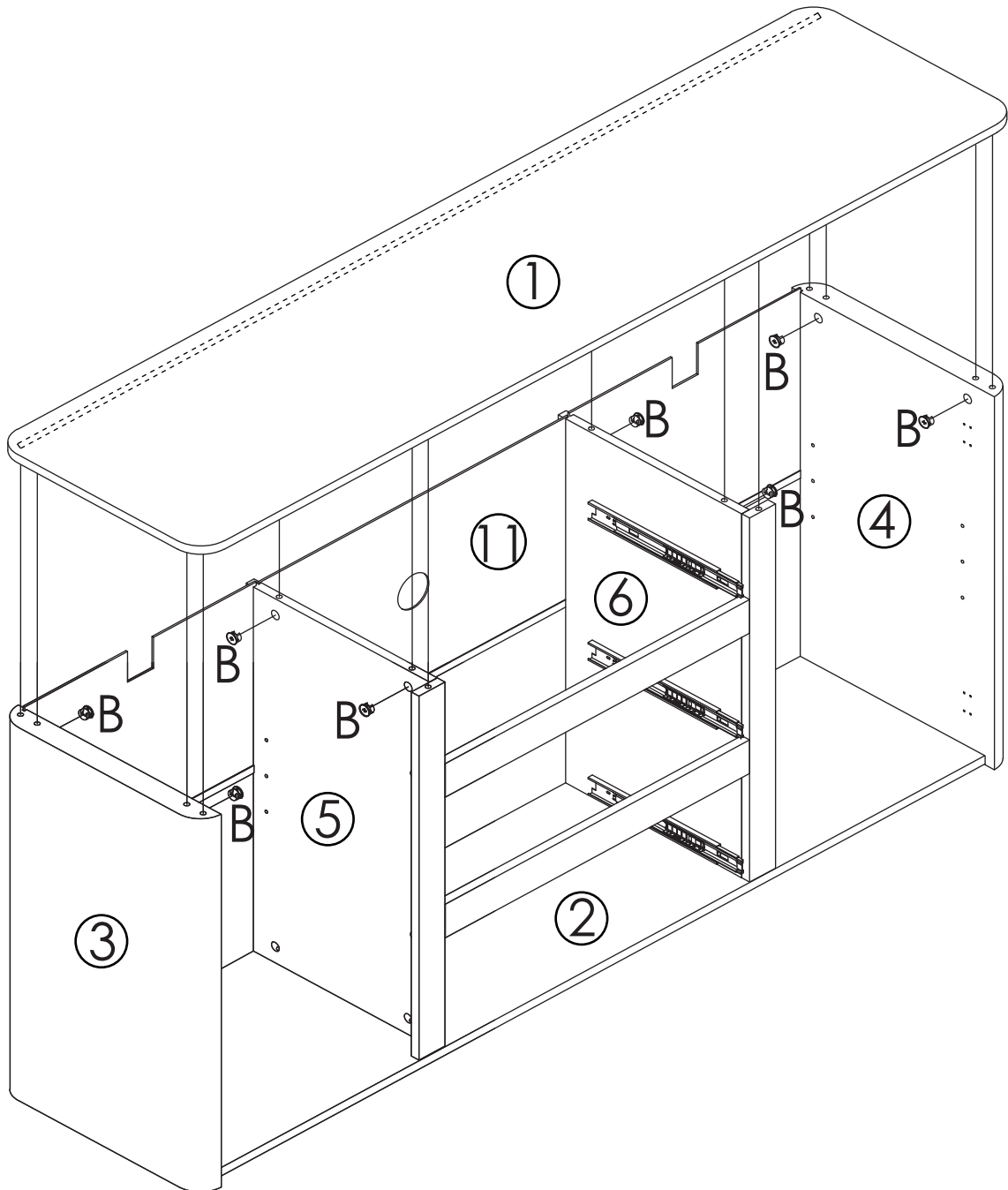

B×8

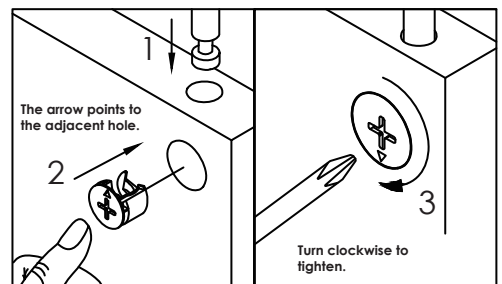

14. Attach Part 26 and Part 27 to Part 2. Cover visible Cam Locks with Stickers J.

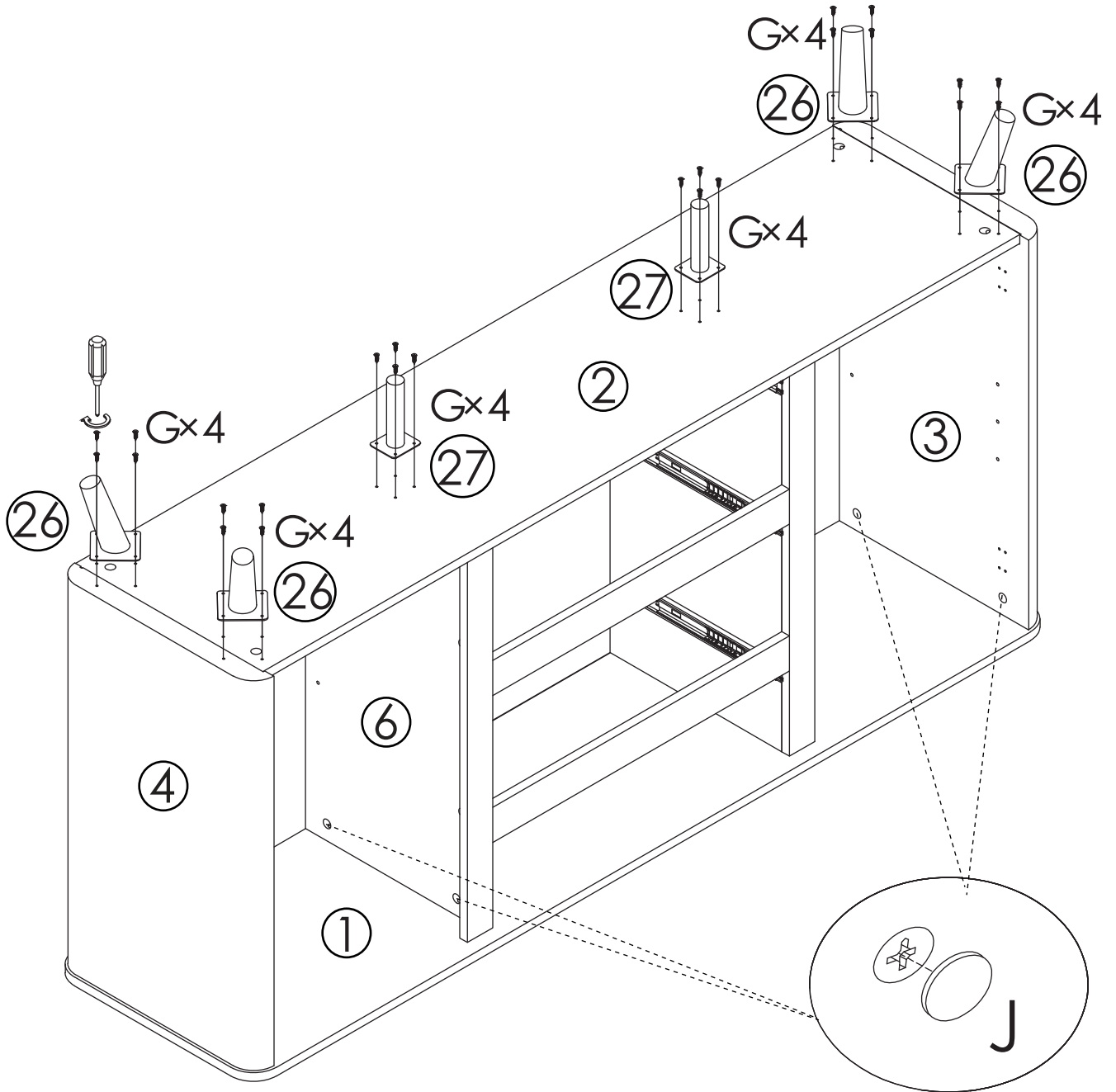

-  Gx24
-  Jx36

15. Attach Part H to the back of the unit using Screws I.

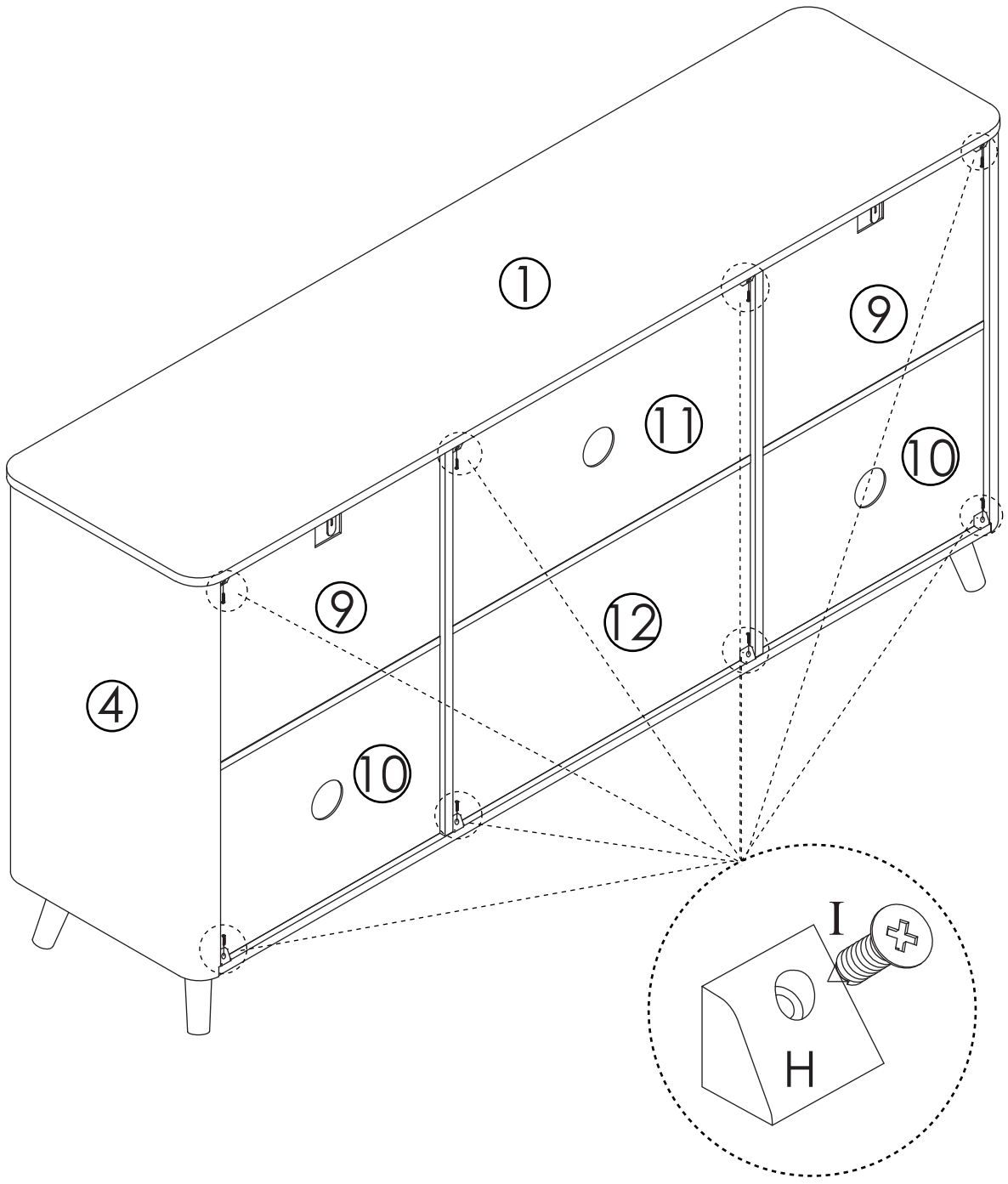

 H×8

 I×8

16. Secure the Wall Anchor N into the wall and connect the Part M to the wall using Screws O.

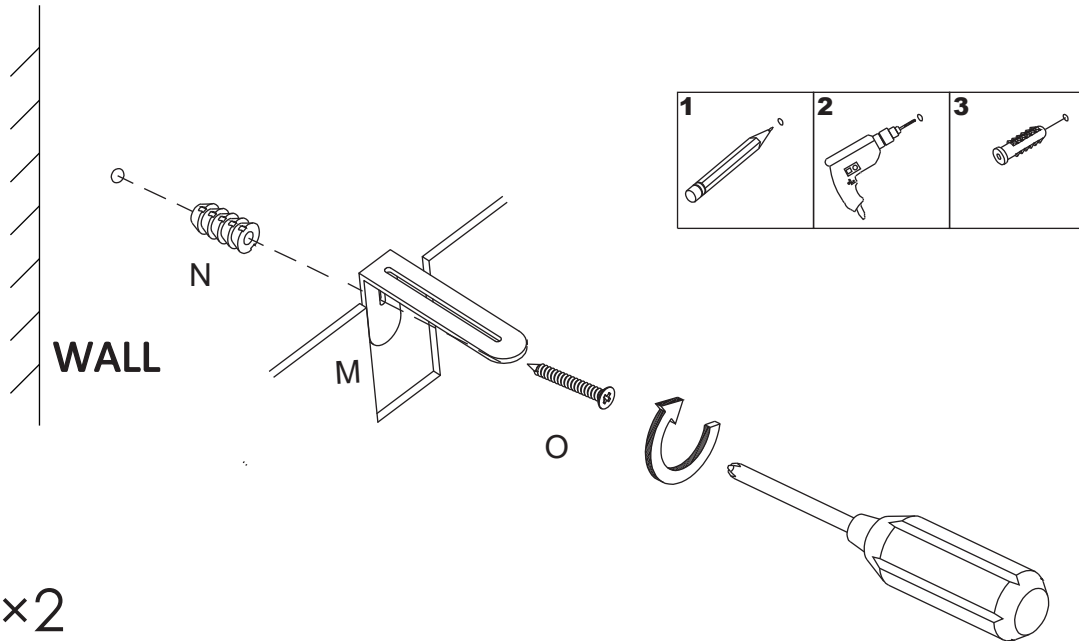

 N×2

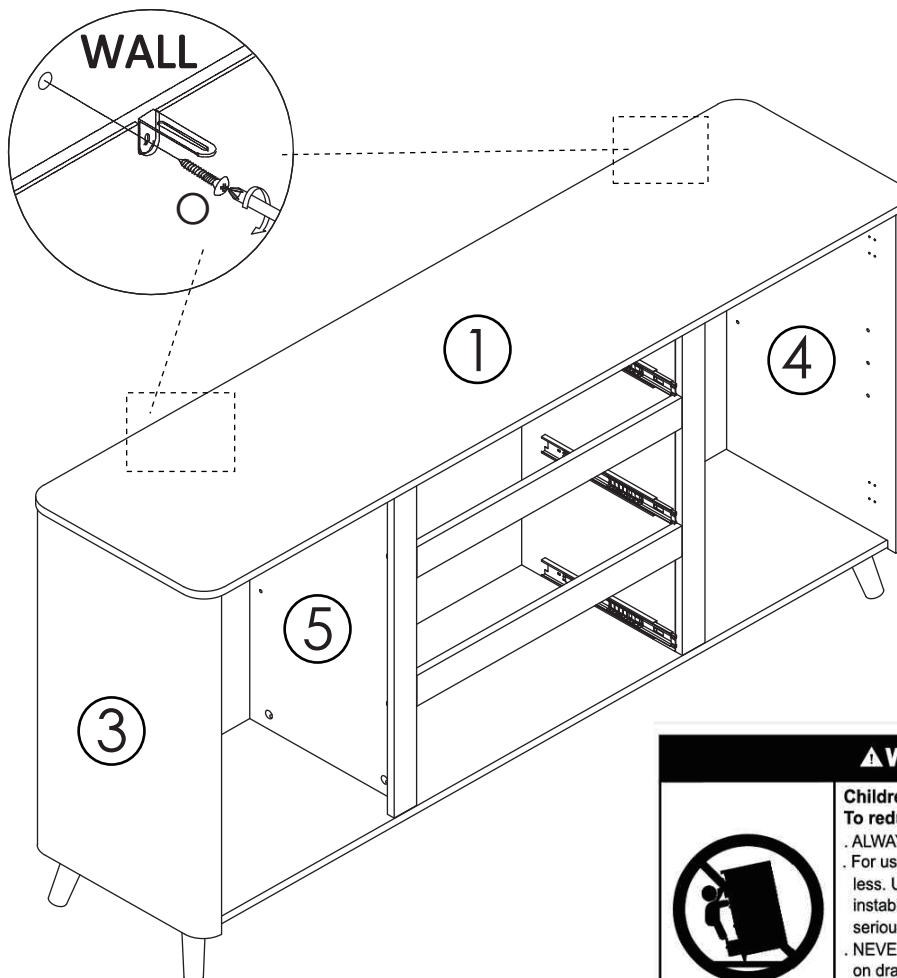

 O×2

<b>⚠ WARNING</b>	
	<b>Children have died from furniture tipover.</b> <b>To reduce the risk of furniture tipover:</b>
	· ALWAYS install tipover restraint provided.
	· For use with televisions weighing 50lbs(23kg) or less. Use with heavier televisions may result in instability causing tip-over resulting in death or serious injury.
	· NEVER allow children to stand, climb or hang on drawers, doors, or shelves.
	· NEVER open more than one drawer at a time.
	· Place heaviest items in the lowest drawers.
	<i>This is a permanent label. Do not remove!</i>

17. Insert K into your desired shelf location. Then slide Part 7 into place. Adjust the feet to level the unit on the floor.

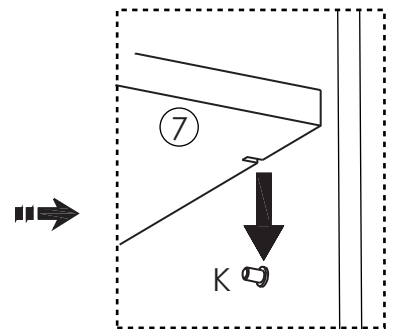
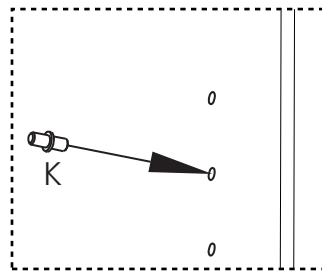
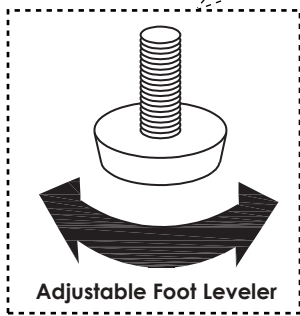
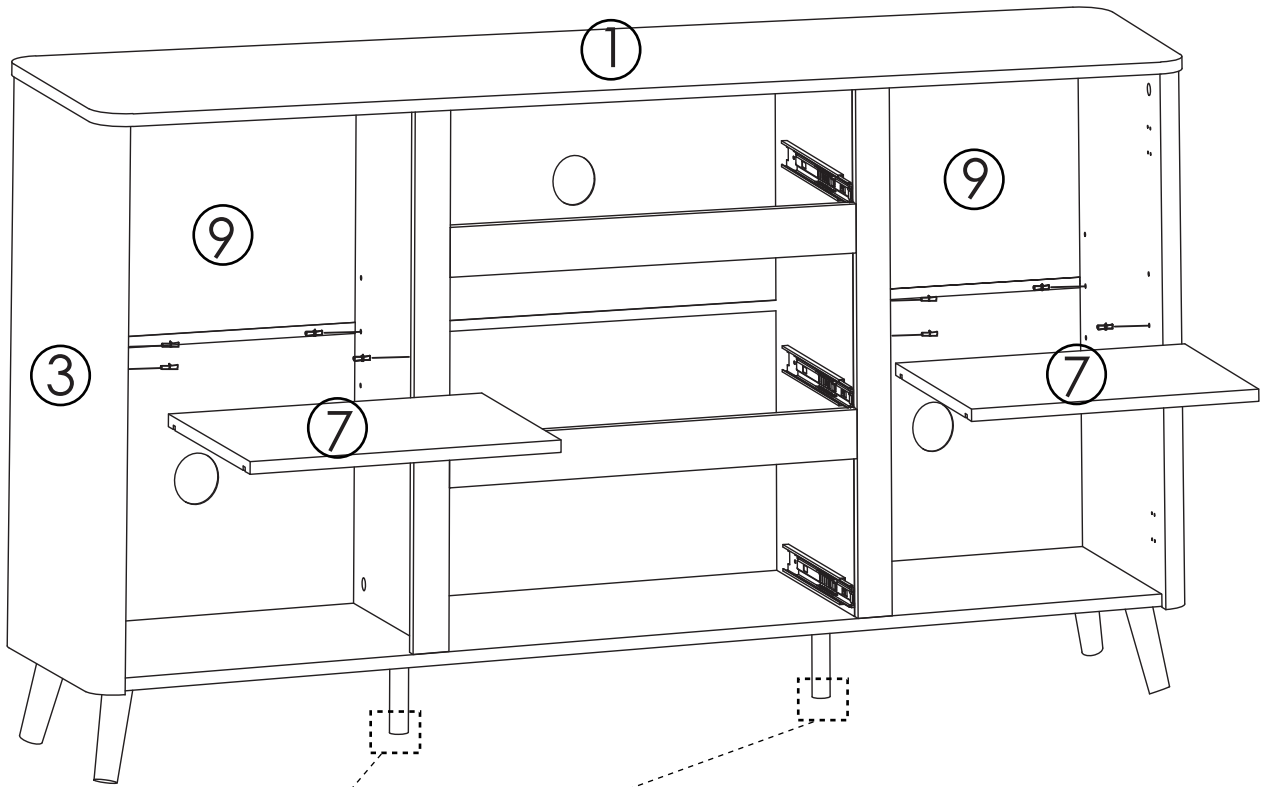

 K×8

18. Attach Hinges L to Part 16 using Screws F.

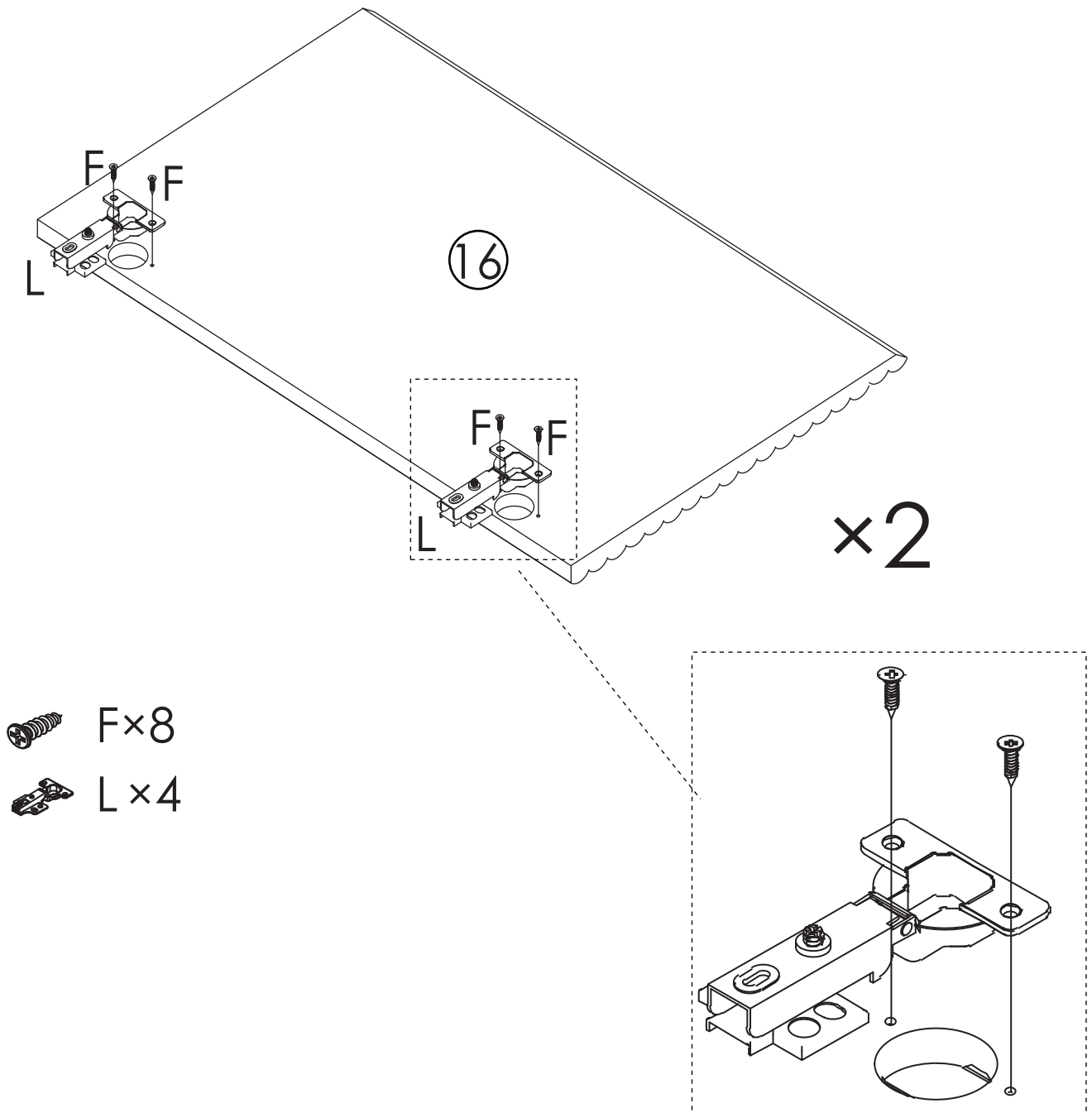

19. Attach Hinges L to the frame using Screws F. Adjust the cabinet doors as indicated below.

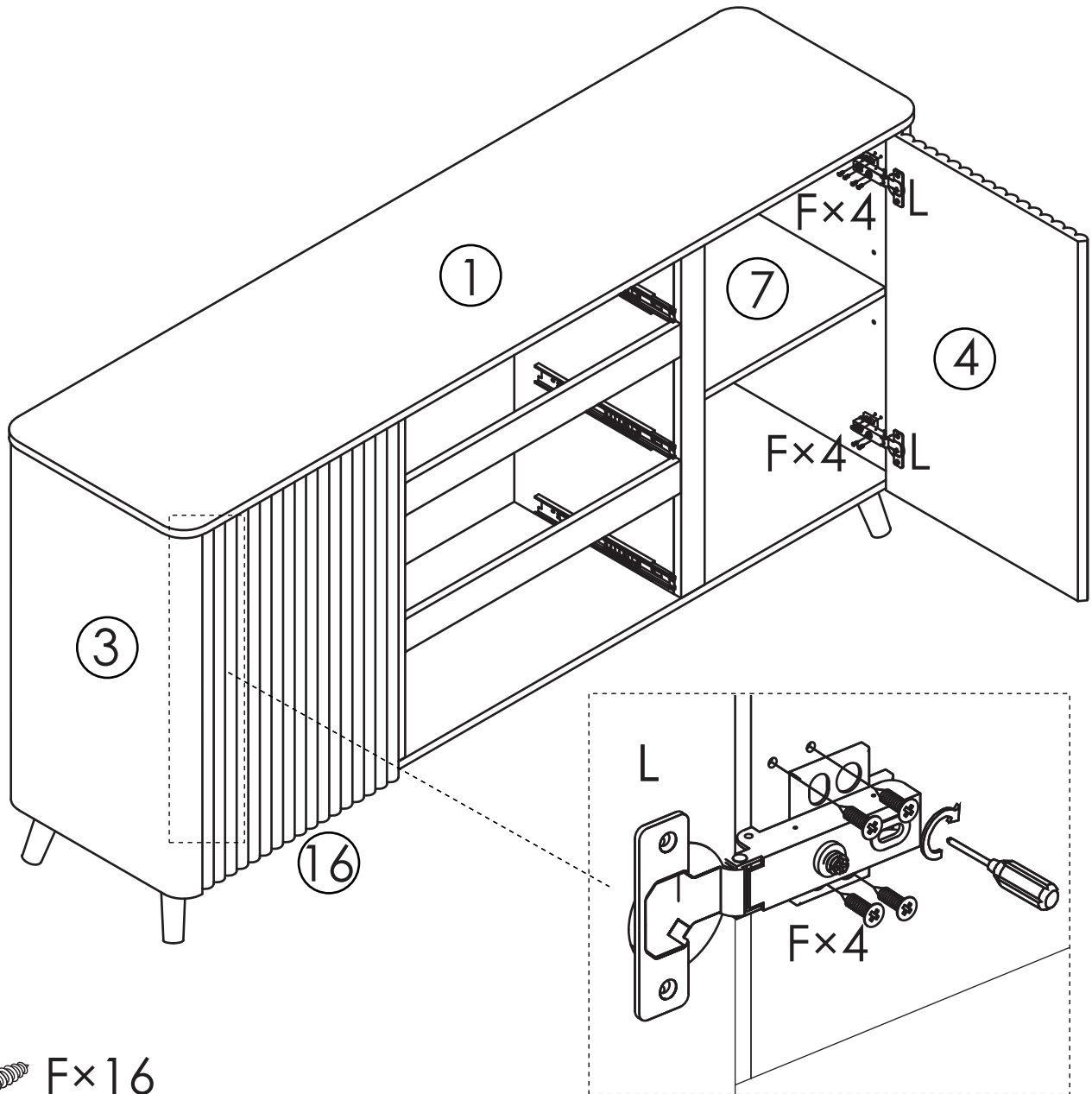

 F x 16

### Adjusting The Cabinet Doors

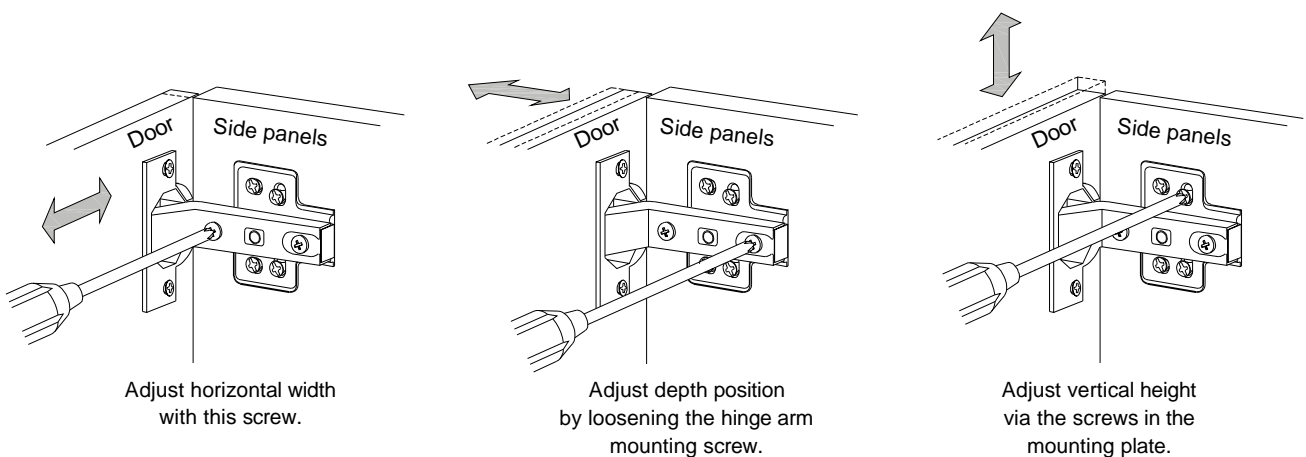

20. Attach Part 22 and Part 24 to Part 23 using Screws E. Insert Part 20. Use the grooves as your guides to slide into place.

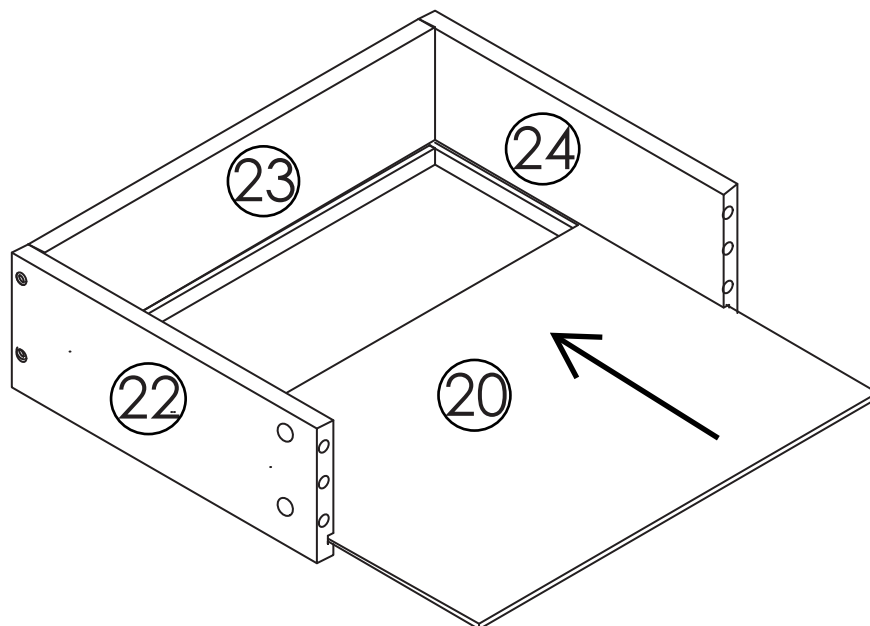
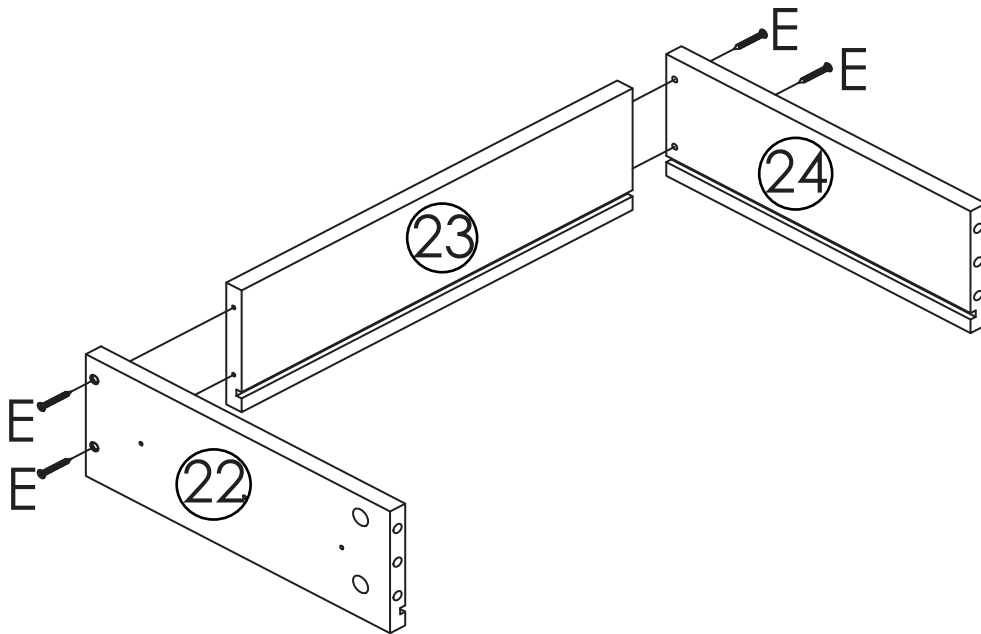

21. Attach Part 17 and Part 18 to Part 19 using Screws E. Insert Part 20. Use the grooves as your guides to slide into place.

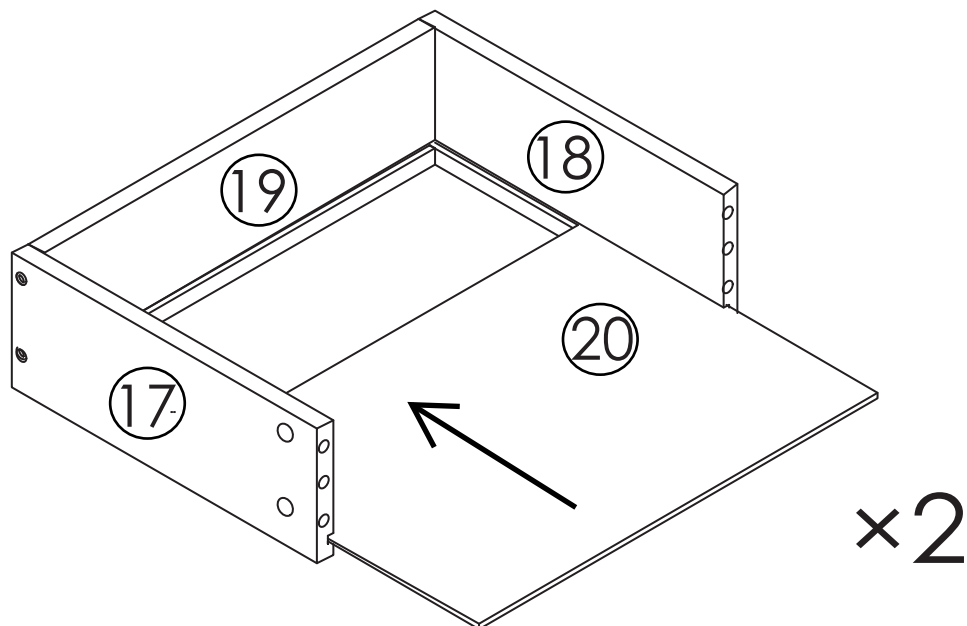
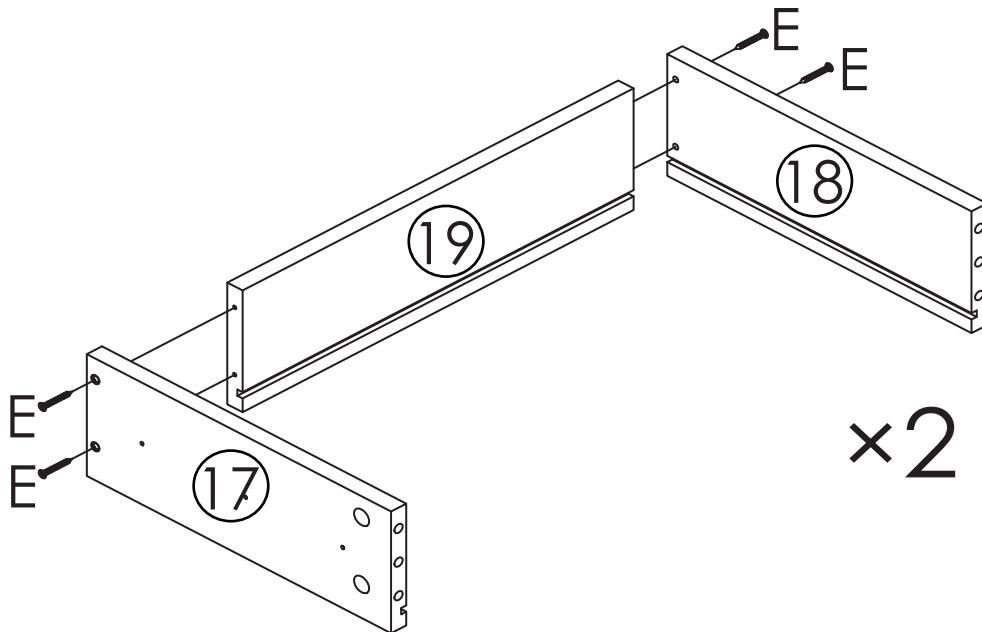

22. Screw Cam Bolts A into Part 25 and Part 21. Insert Dowels C into Part 25 and Part 21.

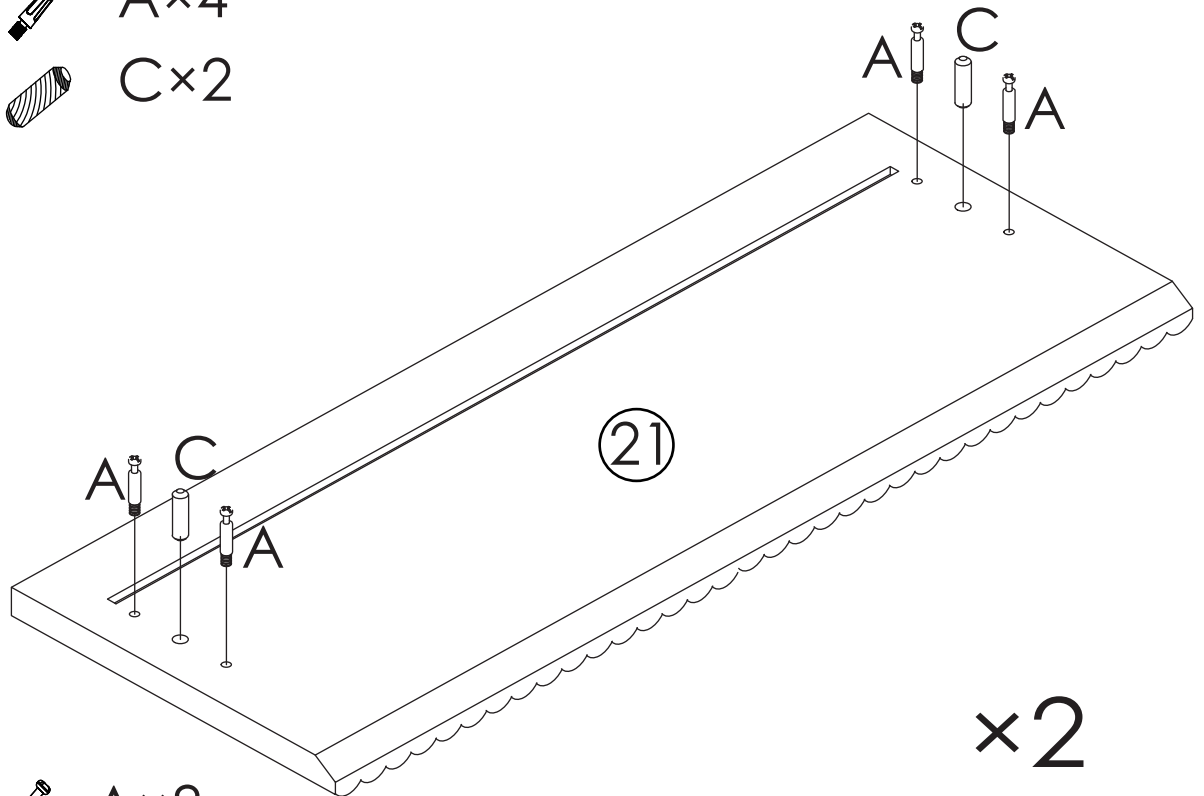
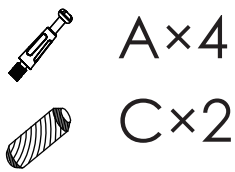
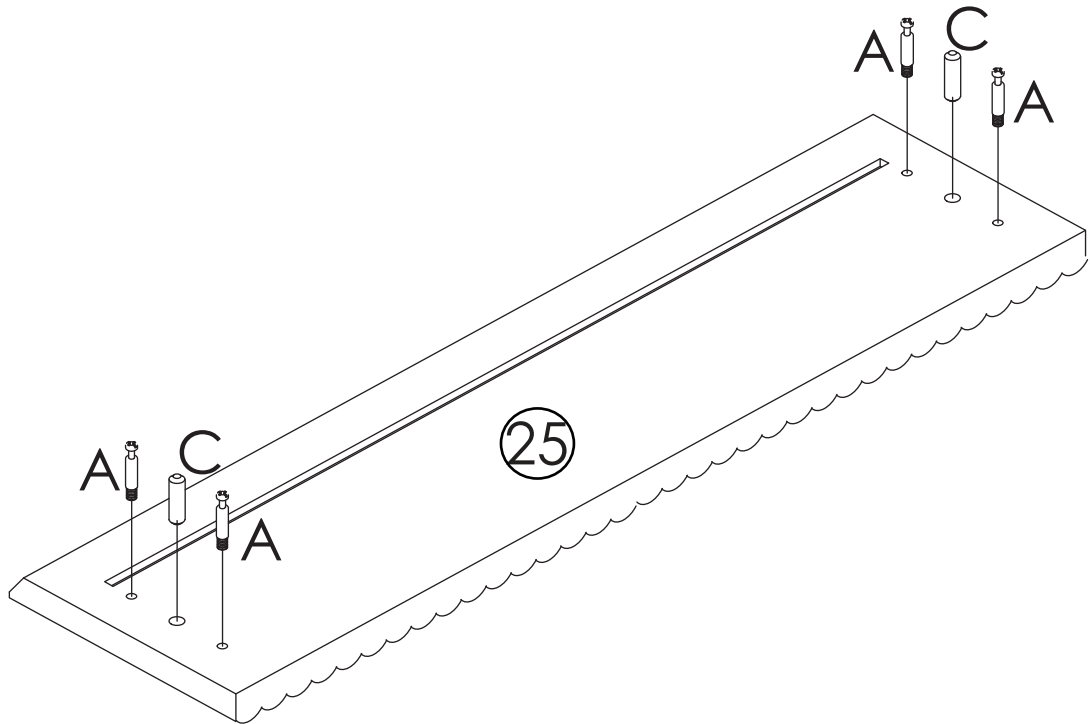

23. Attach the assembled parts of previous step to Part 25 and Part 21. Secure with Cam Locks B. Please pay attention to the arrow direction on Cam Locks B.

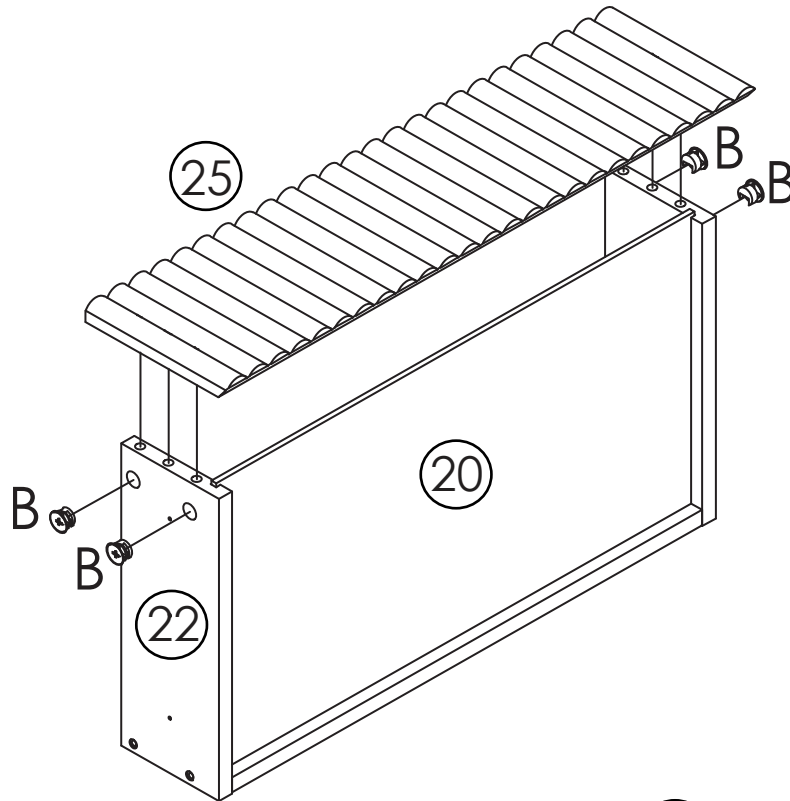

 B×4

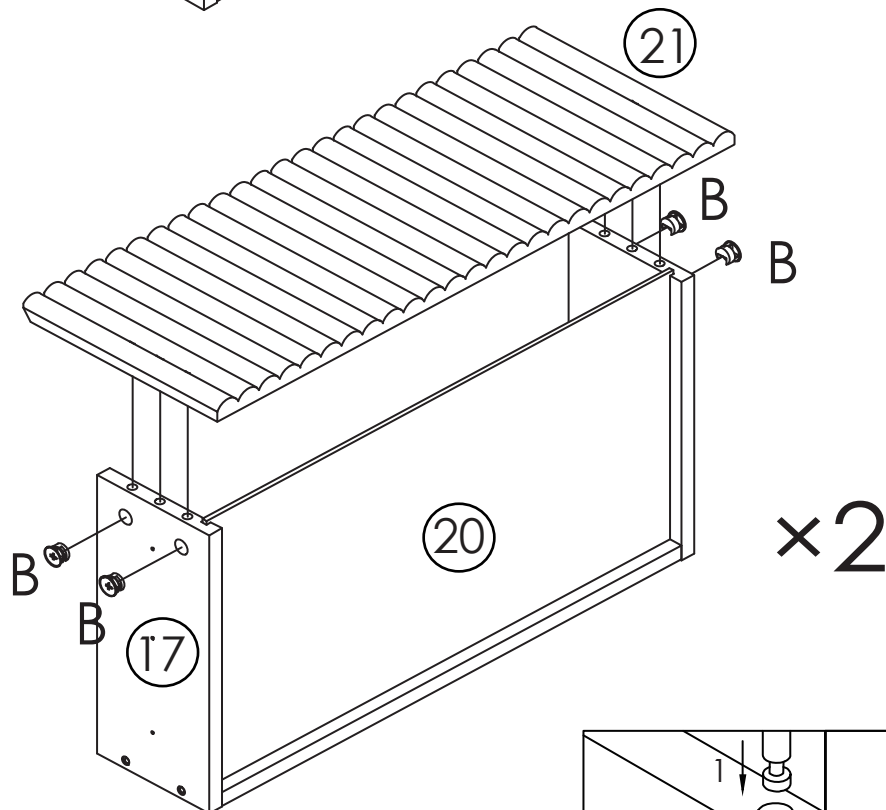

 B×8

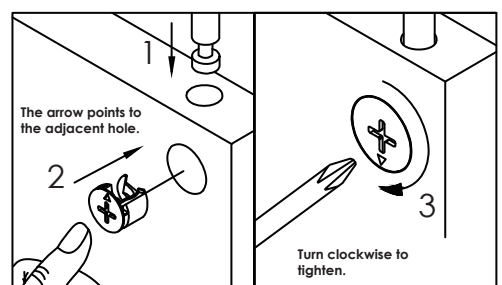

24. Attach D2 to Part 24 and Part 22 using Screws F.

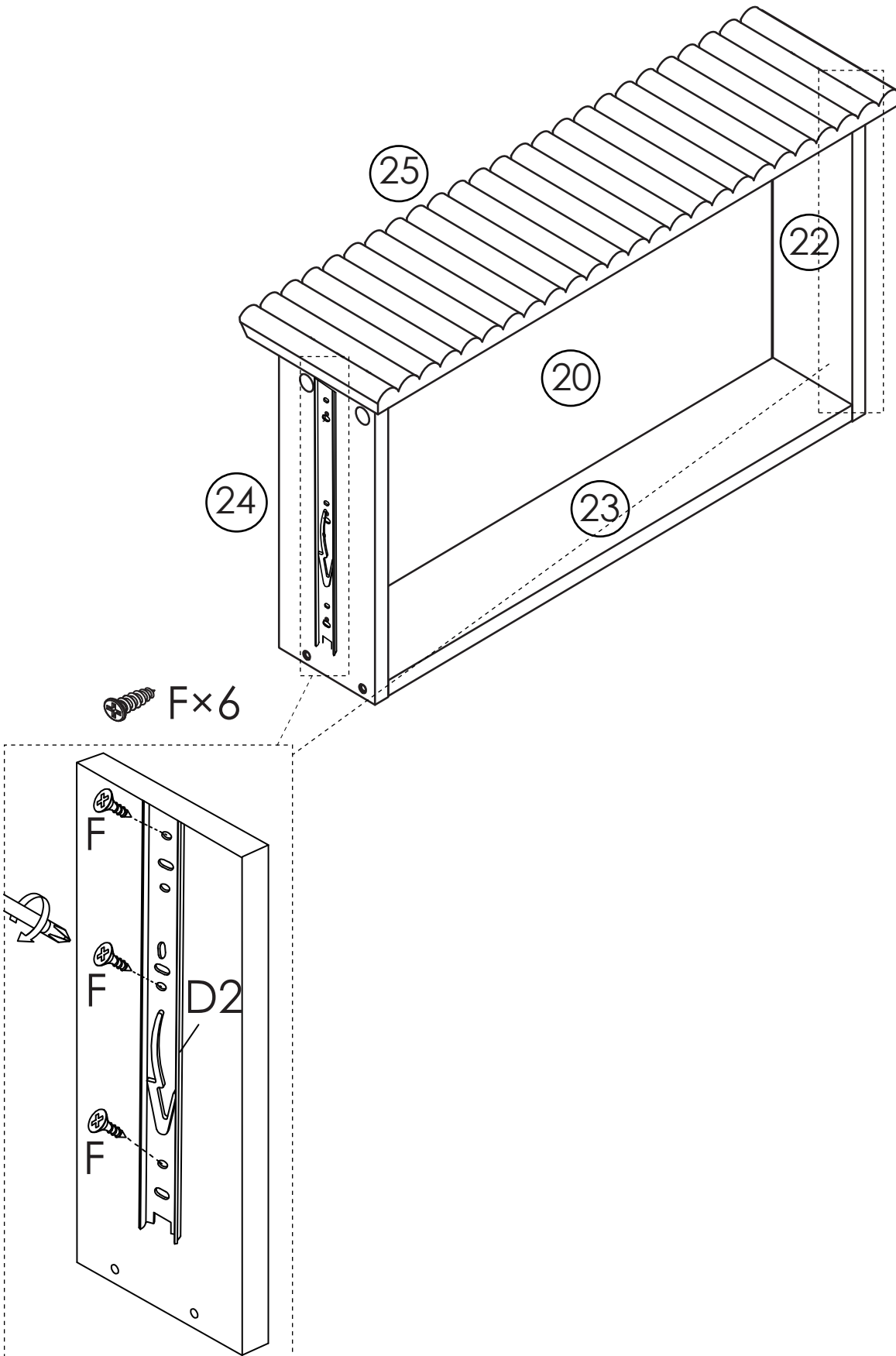

25. Attach D2 to Part 18 and Part 17 using Screws F.

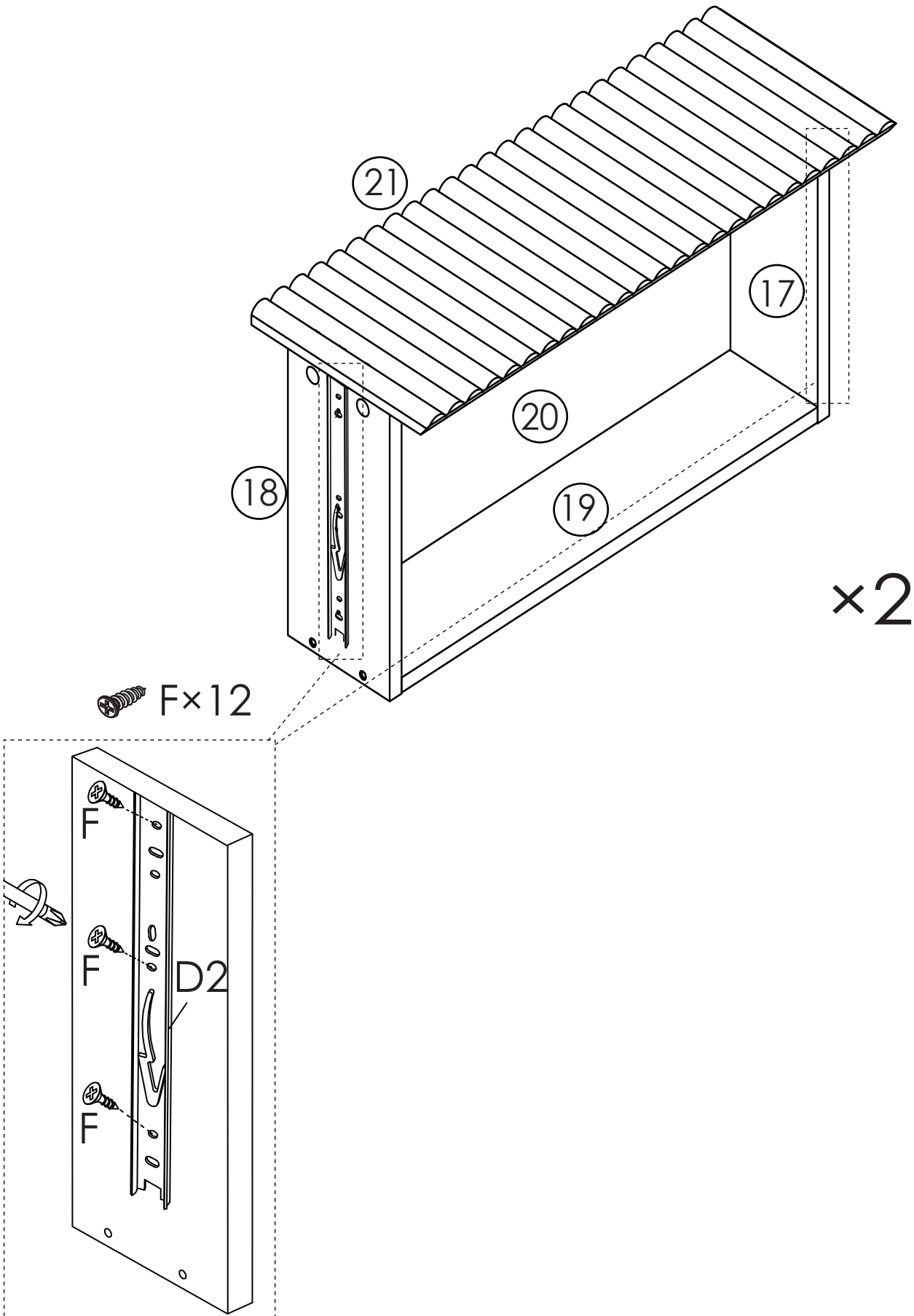

26. Slide three drawers into the unit. Line up the drawer member so it is inside the guides of the cabinet member. Once the connection is made, push the drawer into place entirely. It may not be a smooth glide on your first try, but will improve after it's fully inserted.

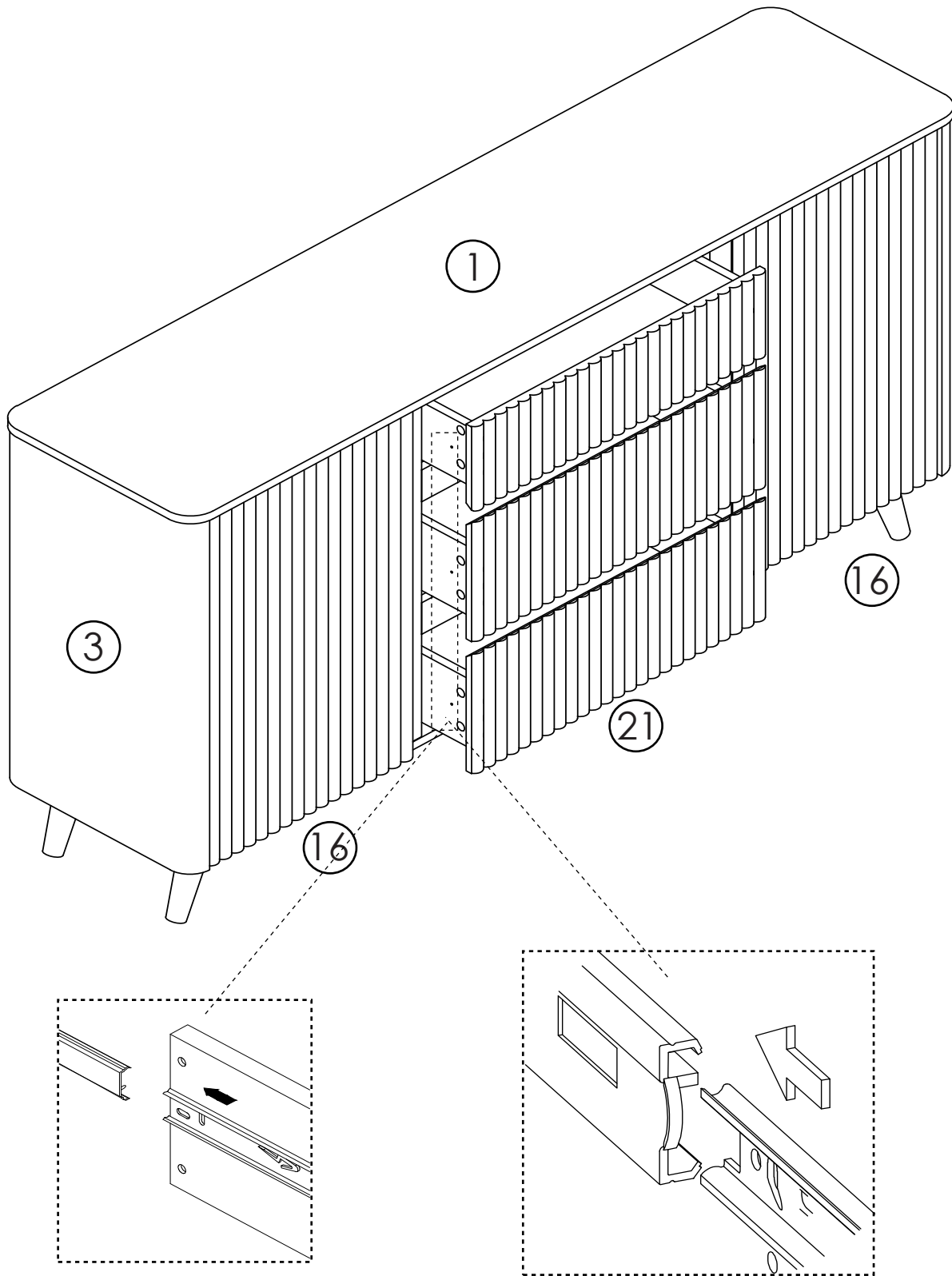

27. Assembly complete. Enjoy.

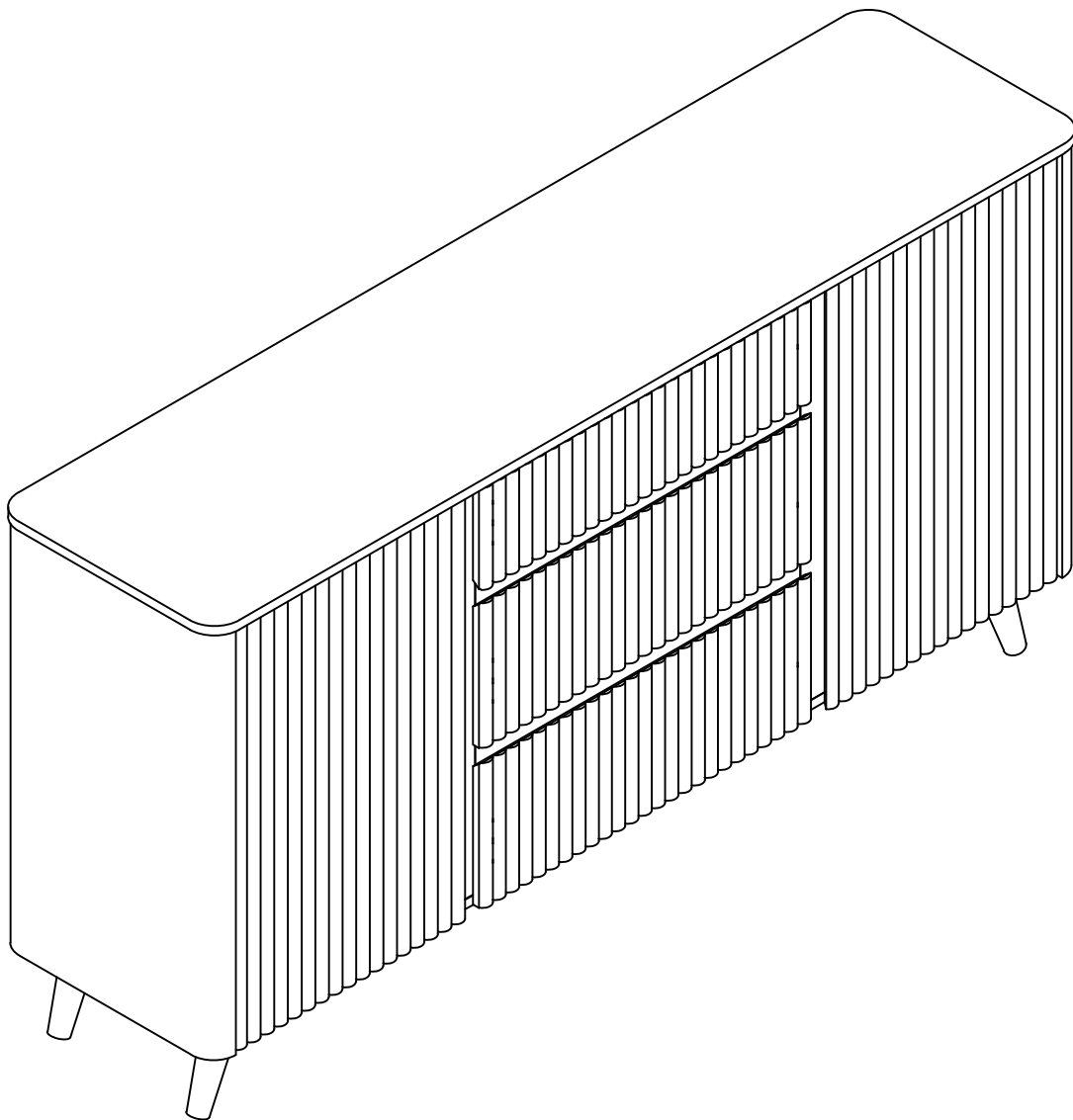

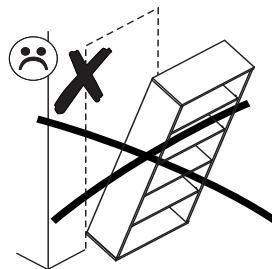
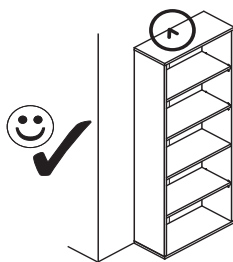

EN.

WARNING! To prevent this furniture from tripping over, fix it to the wall permanently. The package includes fastening elements only suitable for concrete or full-brick walls. If your wall is made of a different material or you are unsure as to the construction of the wall, please consult a specialist regarding installation.

D.

ACHTUNG! Um alle mit dem Umkippen des Möbels verbundenen Risiken auszuschließen, muss das Möbel fest an der Wand verankert werden. Die im Paket enthaltenen Beschläge für die Wandbefestigung sind ausschließlich für Wände aus Beton oder Vollziegeln geeignet. Sollten die heimischen Wände aus anderem Baumaterial bestehen oder sollte es Zweifel in Hinsicht auf dieses Baumaterial geben, bitte eine Fachkraft zu Rate ziehen.

FR.

ATTENTION! Ce meuble doit être fixé en permanence au mur pour éviter les risques de chute. L'ensemble comprend des moyens de fixation adaptés uniquement aux murs de béton ou de brique. Si votre mur est fait d'un matériau différent ou si vous êtes incertain quant à la construction du mur, consultez un spécialiste.

I.

ATTENZIONE! Il mobile deve essere permanentemente fissato alla parete per evitare i rischi derivanti da un ribaltamento del mobile. La confezione contiene solo elementi di fissaggio adatti per pareti in calcestruzzo o in latrezio pieno. Se la vostra parete è realizzata in materiale diverso o avete dubbi sulla costruzione della parete, consultare uno specialista per un montaggio corretto.

RU.

ПРИМЕЧАНИЕ! Эту мебель необходимо всегда прикреплять к стене, чтобы избежать рисков, связанных с переворотом мебели. В пакете находятся крепежные элементы, которые подходят исключительно к бетонным стенам или из целого кирпича. Если стена изготовлена из другого материала или вы не уверены относительно строения стены, проконсультируйтесь относительно монтажа со специалистом.

PL.

UWAGA! Mebel należy trwale zamocować do ściany, aby uniknąć ryzyka związanego z przewróceniem się mebla. W paczce znajdują się elementy mocujące odpowiednie wyłączenie do ścian betonowych lub z pełnej cegły. Jeżeli Twoja ściana wykonana jest z innego materiału lub nie masz pewności co do budowy tej ściany, skonsultuj się w kwestii montażu ze specjalistą.

SK.

POZOR! Nábytok musí byť trvalo pripevnený k stene tak, aby sa zamedzilo riziku prevrátenia. V balíku sa nachádzajú upevňovacie komponenty výlučne pre betónové steny alebo steny z plnej tehly. Ak je Vaša stena z iného materiálu alebo ak si nie ste istí, z čoho je stena vyhotovená, vyžiadajte si odbornú pomoc.

CZ.

POZOR! Nábytek je nutné pevně připevnit ke zdi, abychom se vyhnuli riziku spojenému s jeho převrnutím. V balíčku se nacházejí připevňující prvky vhodné výhradně do betonových zdí nebo zdí z plných cihel. Pokud jsou Vaše zdi zhotoveny z jiného materiálu nebo si nejste jejich konstrukci jisti, konzultujte otázku montáže se specialistou.

RO.

ATENȚIE! Mobilă trebuie ancorată permanent în perete pentru a evita riscul de răsturnare a mobilei. Pachetul conține elementele de fixare potrivite numai pentru pereții din beton sau din cărămidă solidă. Dacă peretele Dvs. este realizat dintr-un alt material sau nu sunteți sigur care este structura peretelui, consultați un specialist în privința montajului.

NL.

OPMERKING! De meubelen moeten permanent aan de muur worden bevestigd om te voorkomen dat de meubelen kantelen. Het pakket bevat bevestigingselementen die alleen geschikt zijn voor betonnen of massieve bakstenen muren. Als uw muur van een ander materiaal is gemaakt of als u niet zeker bent over de constructie van deze muur, raadpleeg dan een specialist voor de installatie.

TR.

DİKKAT! Devrilmek riskini önlemek için mobilya duvara sabitlenmelidir. Pakette, sadece beton veya tam tuğla duvarlara uygun sabitleme elemanları bulunmaktadır. Eğer duvarınız başka bir malzemedен yapıldıysa veya duvar yapısından emin değilseniz, montaj konusunda bir uzmana danışınız.

AR.  
ملاحظة!

يجب تثبيت الأثاث بإحكام إلى الحائط أو الجدار لتجنب خطر إنقلابه. تحتوي العبوة على مسامير التثبيت التي تناسب الجدران الخرسانية أو الطوب. إذا كان جدارك مصنوعاً من مادة مختلفة أو لم تكن متأكداً من مادة بناءه أسأل المتخصص عن كيفية التثبيت.

E.

¡ATENCIÓN! El mueble debe ser fijado permanentemente a la pared para evitar el riesgo relacionado con el vuelco del mueble. En el paquete hay elementos de fijación adecuados solo para paredes de hormigón o de ladrillo entero. Si su pared está hecha de otro material o no está seguro sobre la construcción de esta pared, consulte el montaje con un especialista.

CN.

注意！本家具需要固定在墙上以免倒塌。本包所含有的固定部件仅适用于混凝土墙及整砖墙。欲使用在其他墙体或不确定墙体时，请向专家询问安装方式。

HR.

NAPOMENA! Namještaj mora biti trajno pričvršćen za zid, kako bi se izbjegao rizik od njegovog prevrtanja. U paketu se nalaze elementi za pričvršćivanje prikladni isključivo za betonske zidove ili punu ciglu. Ako je Vaš zid izrađen od drugog materijala ili niste sigurni od čega je napravljen Vaš zid, konzultirajte se sa stručnjakom u vezi sa montažom.

SLO.

POZOR! Pohištvo trajno pritrđite na steno, da preprečite tveganje, da se prevrne. V paketu so pritrđilni elementi, ki so ustrezni izključno za betonske stene in za stene iz polne opeke. Če je vaša stena izdelana iz drugih materialov ali niste gotovi glede konstrukcije stene, se o montaži posvetujte s strokovnjakom.

HU.

FIGYELEM! Rögzítse a bútorokat a falhoz, hogy elkerülje a bútor felborulásának kockázatát. A készletben kizárólag beton- vagy téglafalhoz használható kötőelemek találhatók. Ha a fal más anyagból készült, vagy ha nem tudja, milyen falak találhatók otthonában, forduljon szakemberhez.