

# ASCH 24

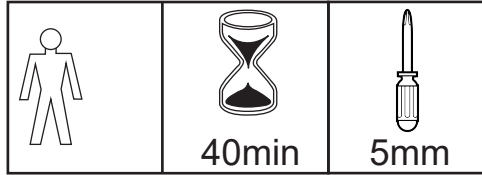

Thank you for choosing this furniture.

**PLEASE RETAIN ALL PACKING UNTIL YOU HAVE COMPLETED ASSEMBLY.**

This furniture is suitable for indoor use only.

### Caring for your furniture.

Any fluid spills, especially strong coloured liquids should be removed as quickly as possible.

Do not place hot objects directly onto surfaces.

Always lift your furniture when moving as dragging may cause damage to your furniture or flooring.

### Indoor use.

Please avoid placing your furniture close to radiators or other direct sources of heat as it may cause distortion.

### After care.

Do not use a pressure washer as it may damage the surface.

Wipe the surfaces with a damp cloth, do not use bleach, solvents or abrasive cleaners.

Retain the Allen key provided and periodically check all fixings and tighten if necessary.

### Recycling.









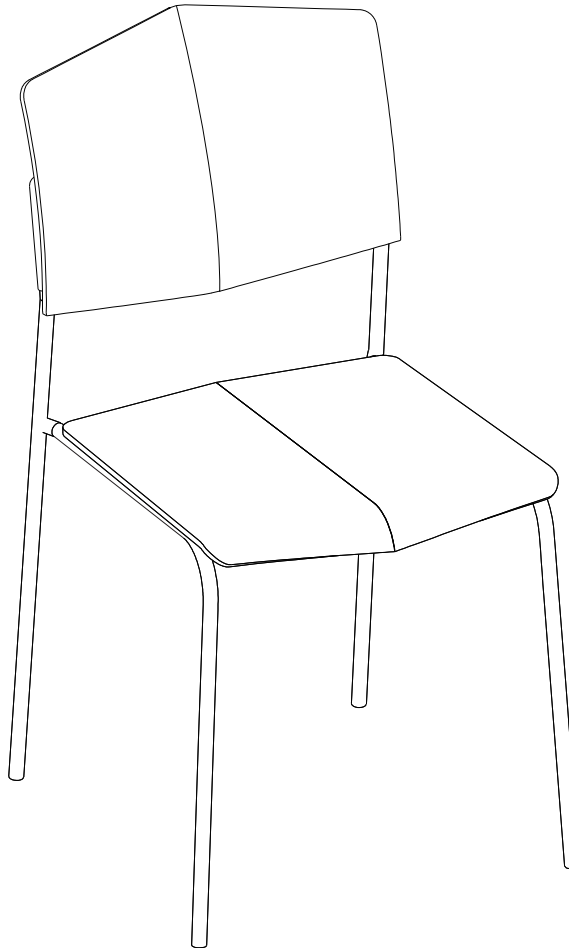



Packaging is suitable for local recycling.

At end of use this product should not be discarded with household waste. Please dismantle and separate the components for disposal at your local authority waste disposal centre.

## PARTS LIST

Build your furniture on a soft clean cover to stop the components from getting marked during assembly.



 ①×1	 Ax1
 ②×1	 Bx8
 ③×1	 Cx8
 ④×1	 Dx4
 365mm ⑤×1	 Ex4
 375mm ⑥×1	 Fx2
	 Gx4

### BEFORE YOU START ASSEMBLY

Please check you have all the correct parts and fittings as detailed on the parts list above.

In the unlikely event that you require spare parts please refer to your delivery note for details of how to order on our parts website.

[www.coreproducts.co.uk/parts](http://www.coreproducts.co.uk/parts)

BATCH NUMBER







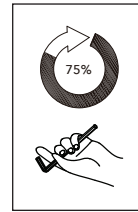
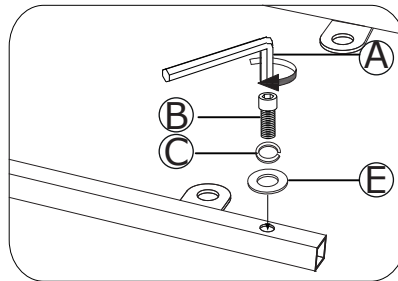
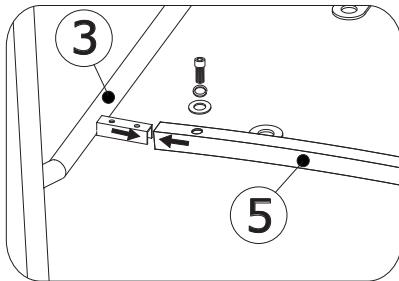
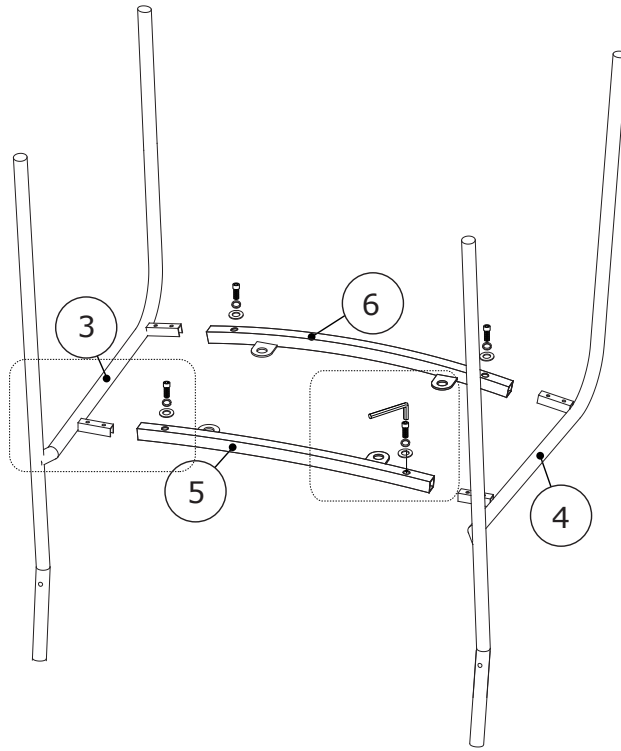

**FENG7456**

Manufactured in PRC for Core Products Ltd, Perth, Scotland. PH1 3DZ



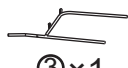





1

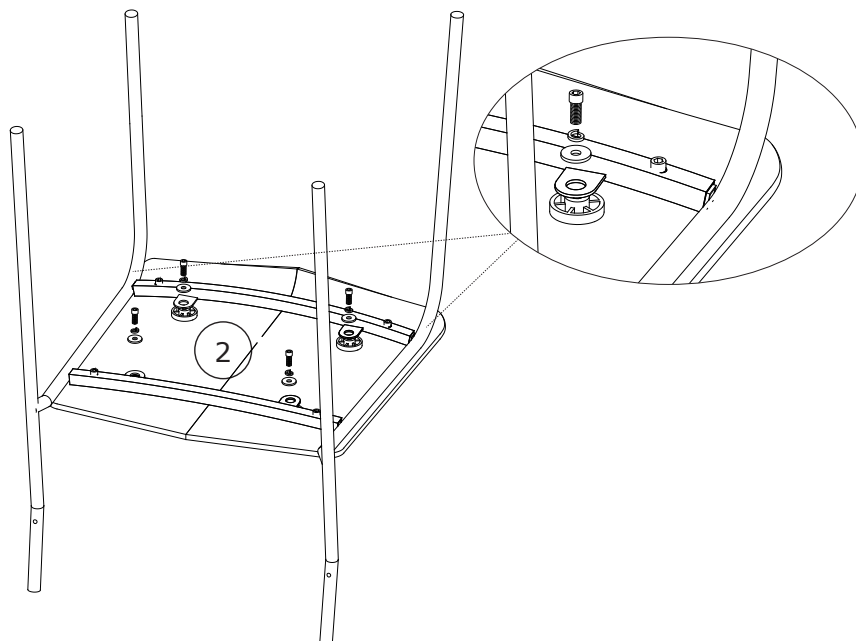
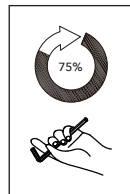
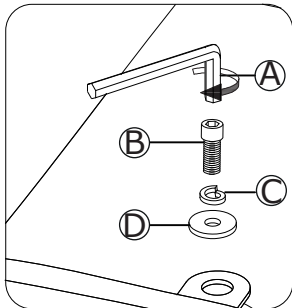

-  Ax1
-  Bx4
-  Cx4
-  Ex4
-  ③x1
-  ④x1
-  365mm  
⑤x1
-  375mm  
⑥x1

2



-  Ax1
-  Bx4
-  Cx4
-  Dx4
-  ②x1

3



Gx4

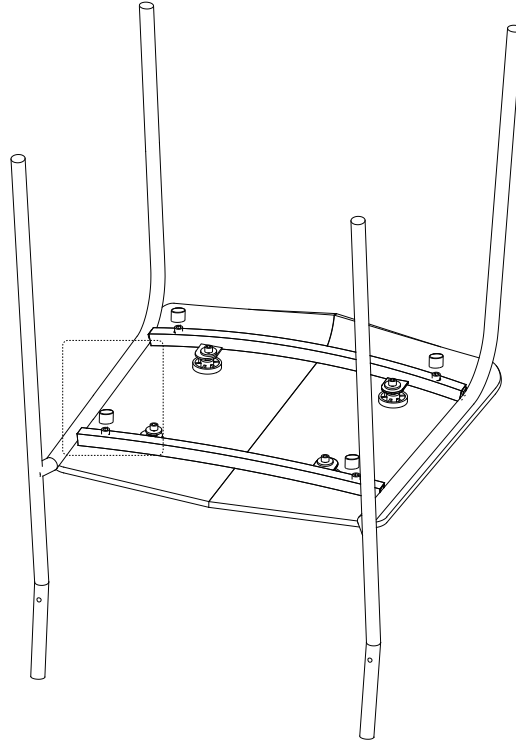
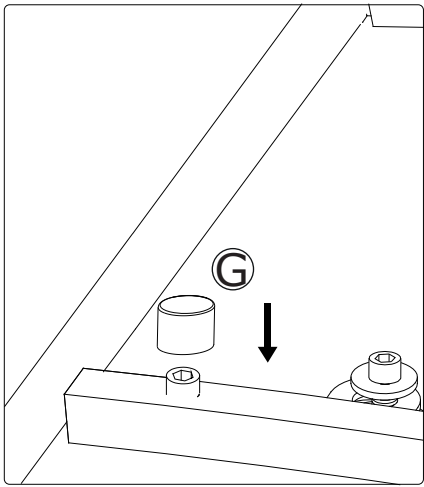

4



Fx2

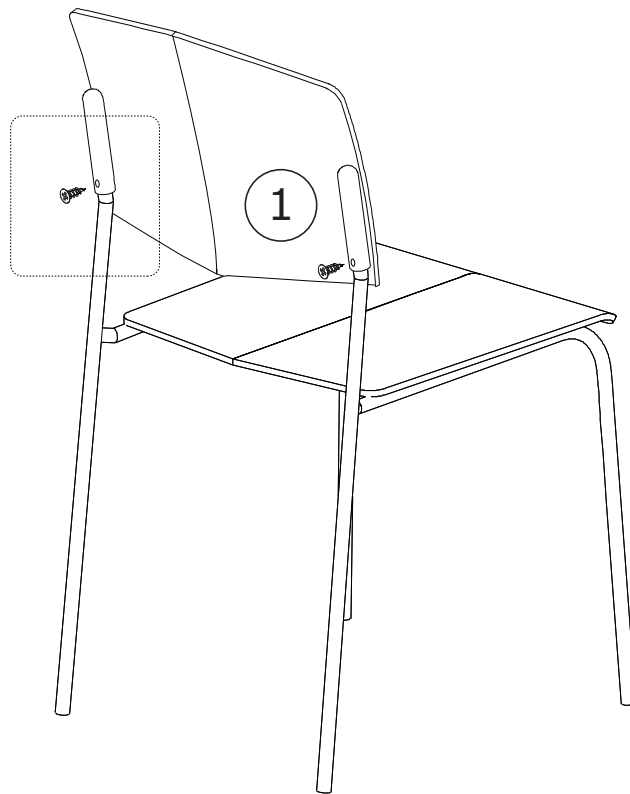
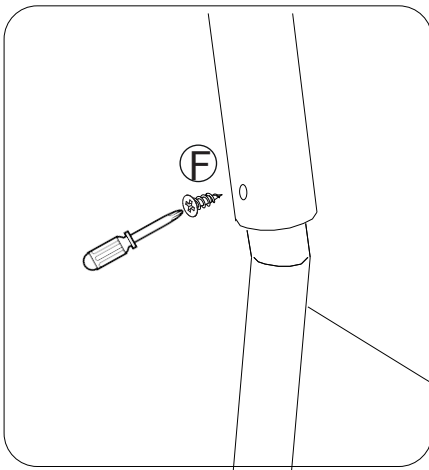

5

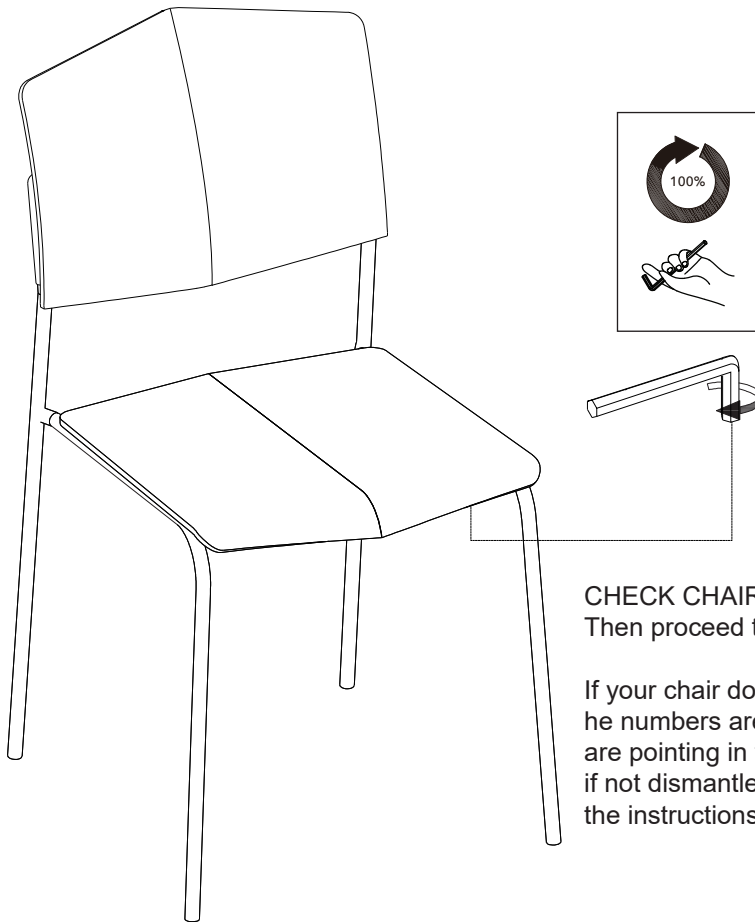

CHECK CHAIR SITS LEVEL ON A LEVEL FLOOR  
Then proceed to tighten fully all bolts in each chair.

If your chair does not sit level on a level floor check all the numbers are in the correct order and the arrows are pointing in the direction indicated on these instructions if not dismantle the chair and re-assemble according to the instructions.

**RETAIN ALLEN KEY TO TIGHTEN BOLTS WHEN NECESSARY**