

Important Safety Information · Informations de Sécurité Importantes

- EN** • Please carefully read all instructions before attempting installation. If you DO NOT understand the instructions or have any questions or concerns, please call technical support or email customer service.

CAUTION: Avoid potential injuries and property damage!

- DO NOT use this product for any purpose that is NOT explicitly specified in this manual. We are NOT liable for damage or injury caused by improper mounting, incorrect assembly or inappropriate use.

WARNING: This product contains small parts that may pose a choking hazard.

- Before starting assembly, verify all parts are included and undamaged. DO NOT use damaged or defective parts. If you require replacement parts, please call technical support or email customer service.
- To prevent the TV console from tipping over, use the wall attachment device provided with this product.

- FR** • Veuillez lire attentivement toutes les instructions avant de procéder à l'installation. Si vous NE COMPRENEZ PAS les instructions ou si vous avez des questions ou des préoccupations, veuillez appeler le support technique ou envoyer un e-mail au service client.

ATTENTION : Évitez les blessures potentielles et les dommages matériels !

- N'utilisez PAS ce produit à des fins qui ne sont PAS explicitement spécifiées dans ce manuel. Nous ne sommes PAS responsables des dommages ou des blessures causés par un montage incorrect, un assemblage incorrect ou une utilisation inappropriée.

AVERTISSEMENT : Ce produit contient de petites pièces susceptibles de présenter un risque d'étouffement.

- Avant de commencer l'assemblage, vérifiez que toutes les pièces sont incluses et non endommagées. N'utilisez PAS de pièces endommagées ou défectueuses. Si vous avez besoin de pièces de rechange, veuillez appeler le support technique ou envoyer un e-mail au service client.
- Pour éviter que le meuble TV ne bascule, utilisez le dispositif de fixation murale fourni avec ce produit.

Top Panel Weight Capacity:
 · Capacité de poids du
 panneau supérieur :
 200 lbs/livres (90.7kg)



Middle Shelf Weight Capacity:
 · Capacité de poids de l'étagère
 du milieu :
 50 lbs/livres (22.7kg)



· Fits most flat panel TVs
 up to 65" / 165.1cm diagonally
 · Convient à la plupart des
 téléviseurs à écran plat
 jusqu'à 65 po / 165,1 cm de
 diagonale

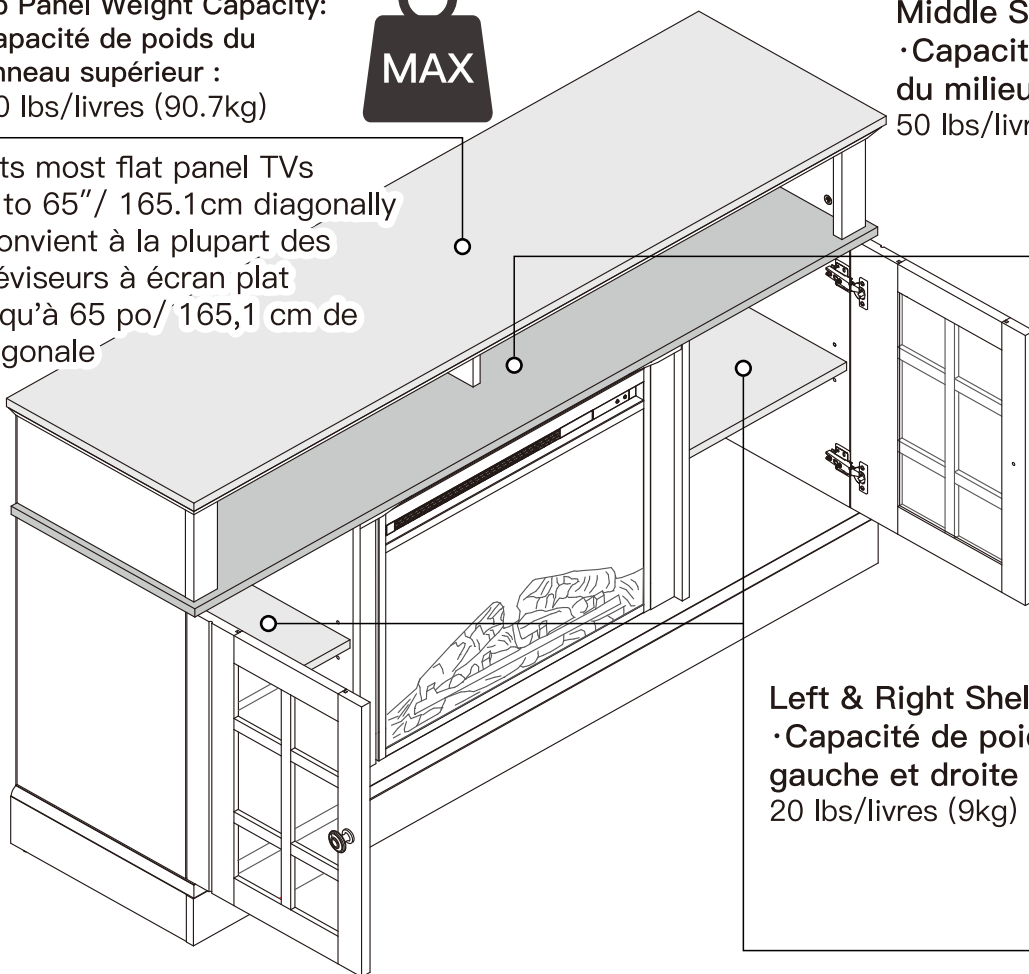

Left & Right Shelf Weight Capacity:
 · Capacité de poids des étagères
 gauche et droite :
 20 lbs/livres (9kg)



Tools Needed (Not Included) · Outils Requis (Non Inclus)



· Phillips Screwdriver
 · Tournevis Phillips

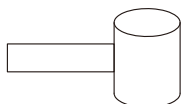

· Rubber Mallet
 · Maillet en caoutchouc

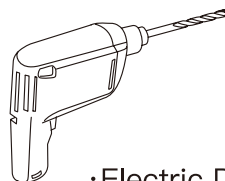

· Electric Drill
 · Perceuse électrique

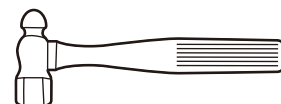

· Hammer
 · Marteau-piqueur

How the Assembly System Works · Fonctionnement du Système d'Assemblage

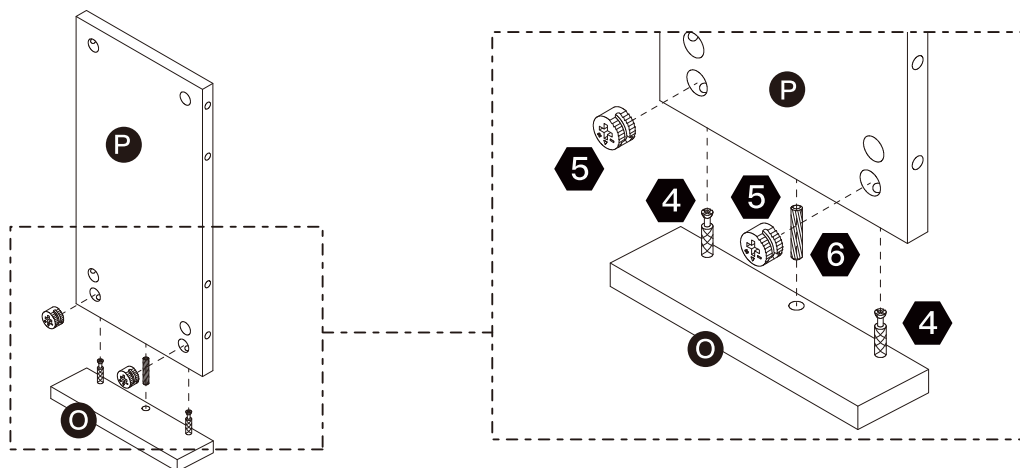

Installing Wood Dowels · Installation des chevilles en bois

EN Insert the wood dowel [6] at least halfway into the hole. IF NECESSARY, lightly tap the wood dowel with a self-supplied rubber mallet.

FR Insérez la cheville en bois [6] au moins à mi-chemin dans le trou. SI NÉCESSAIRE, tapez légèrement sur la cheville en bois avec un maillet en caoutchouc que vous aurez fourni.

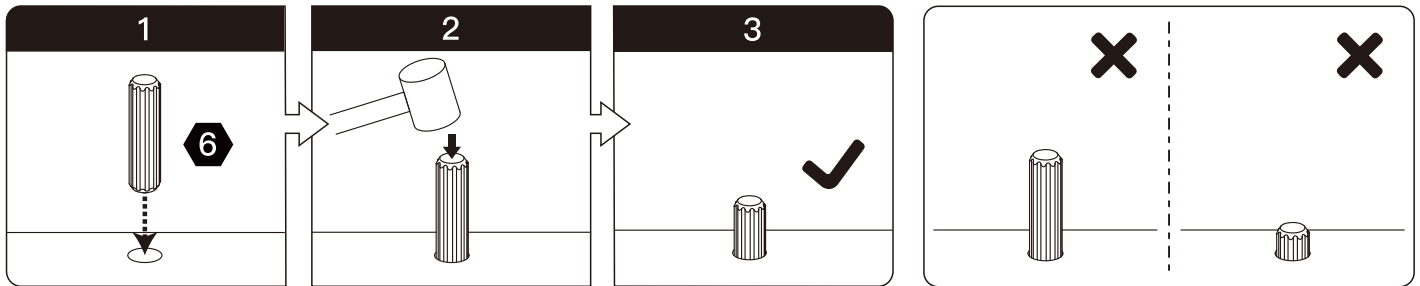

Using the Cam Lock System · Utilisation du système de verrouillage à came

EN

1. Screw cam bolt [4] into the threaded hole on the panel.
2. Connect both panels together. Make sure cam bolt [4] goes into the pre-drilled hole on the end of the panel for cam lock [5].
3. Insert cam lock [5] into the large hole on the panel. Make sure the open slot faces the head of the cam bolt [4].
4. Rotate cam lock [5] clockwise with a Phillips screwdriver to lock the cam bolt [4] in place.

FR

1. Vissez le boulon à came [4] dans le trou fileté du panneau.
2. Connectez les deux panneaux ensemble. Assurez-vous que le boulon à came [4] entre dans le trou pré-percé à l'extrémité du panneau pour le verrou à came [5].
3. Insérez le verrou à came [5] dans le grand trou du panneau. Assurez-vous que la fente ouverte est dirigée vers la tête du boulon à came [4].
4. Tournez le verrou à came [5] dans le sens des aiguilles d'une montre à l'aide d'un tournevis cruciforme pour verrouiller le boulon à came [4] en place.

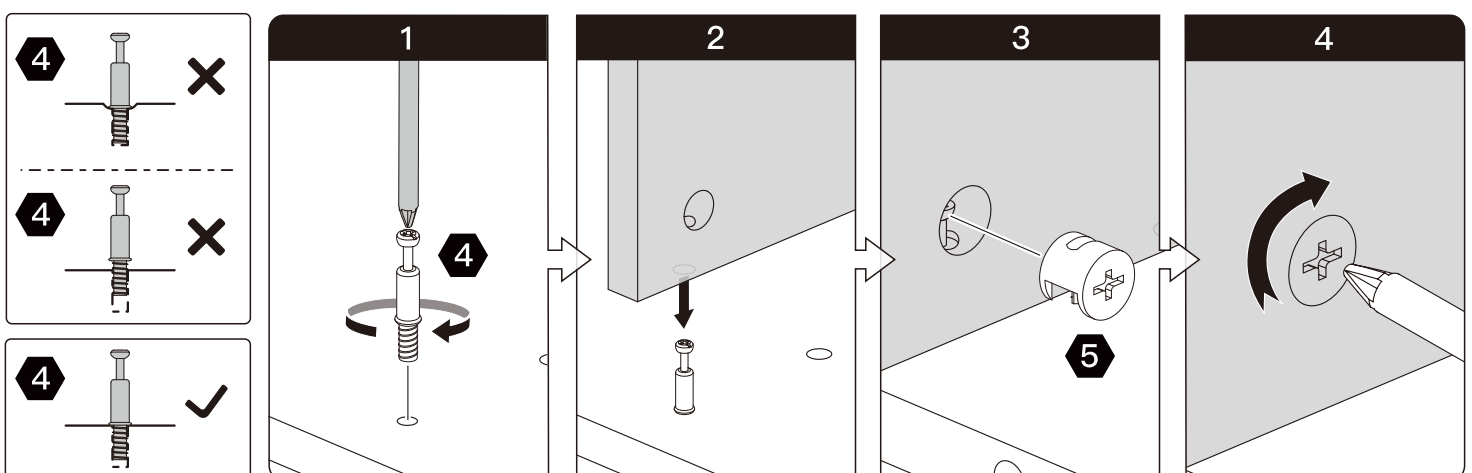

You are now ready to assemble the TV console.

Vous êtes maintenant prêt à assembler la console TV.

Exploded Drawing · Dessin éclaté

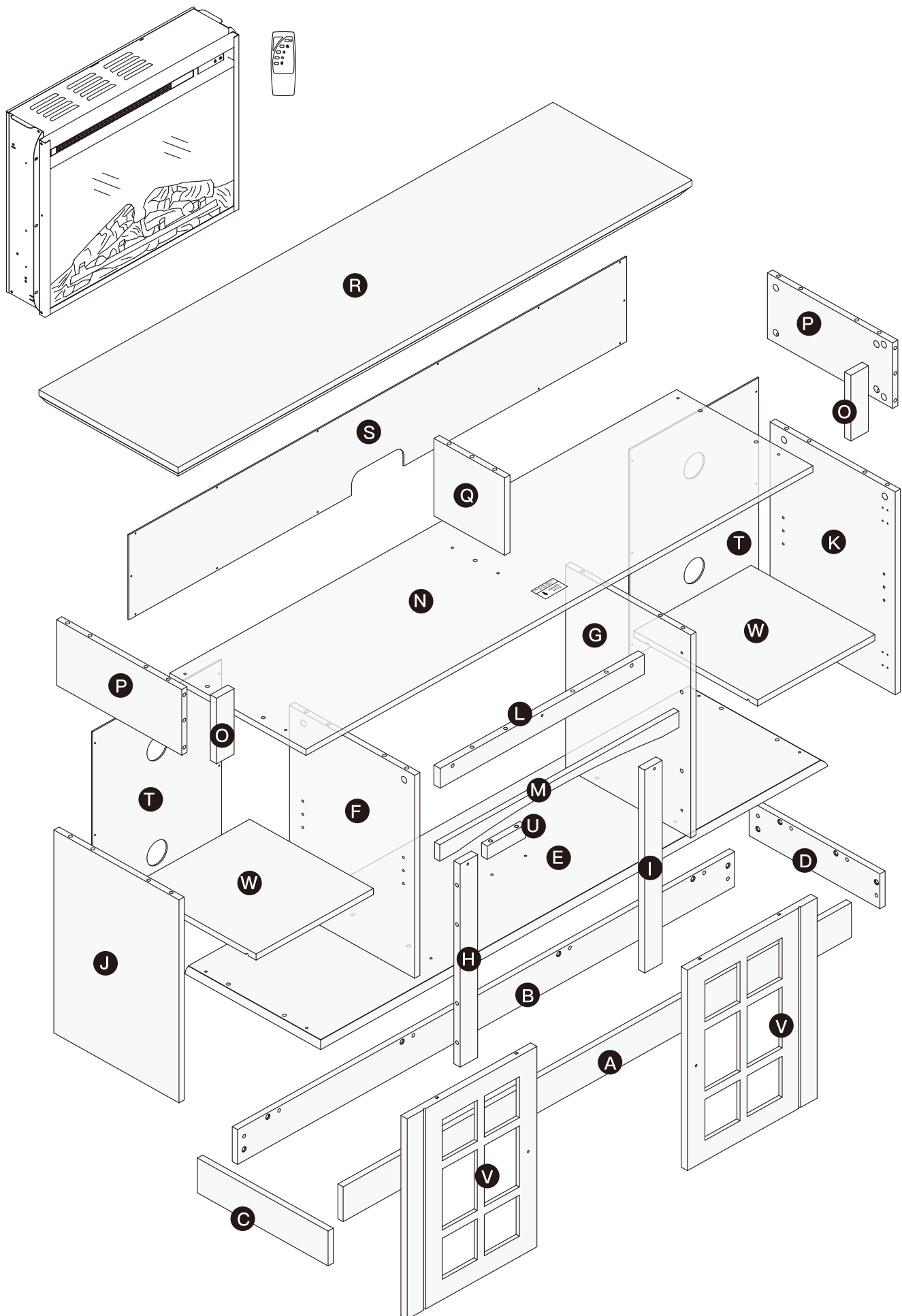

Supplied Parts · Pièces fournies

A

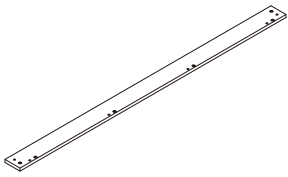

Bottom Front Panel
· Panneau avant inférieur
x 1

B

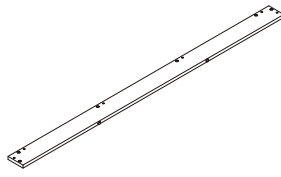

Bottom Back Panel
· Panneau arrière inférieur
x 1

C

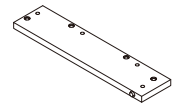

Left Bottom End Panel
· Panneau d'extrémité
inférieur gauche
x 1

D

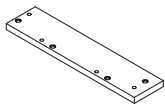

Right Bottom End Panel
· Panneau d'extrémité
inférieur droit
x 1

E

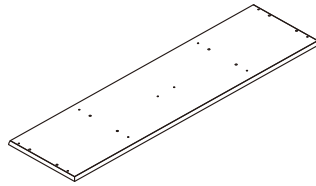

Bottom Panel
· Panneau du bas
x 1

F

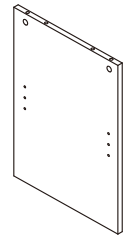

Left Inside Panel
· Panneau intérieur gauche
x 1

G

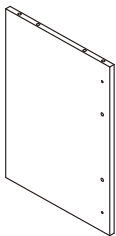

Right Inside Panel
· Panneau intérieur droit
x 1

H



Left Rail
· Rail gauche
x 1

I



Right Rail
· Rail droit
x 1

J

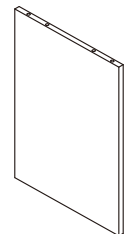

Left Middle End Panel
· Panneau d'extrémité
centrale gauche
x 1

K

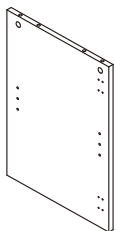

Right Middle End Panel
· Panneau d'extrémité
centrale droite
x 1

L

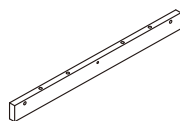

Center Rail
· Rail central
x 1

M

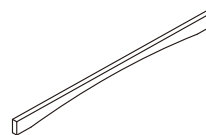

Front Trim
· Garniture avant
x 1

N

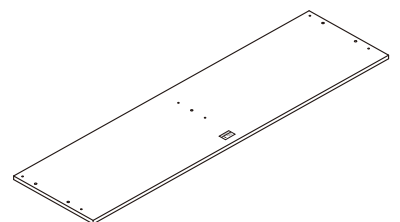

Middle Panel
· Panneau central
x 1

○



Panel Connector
·Connecteur de panneau
x 2

○

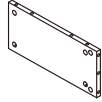

Upper End Panel
·Panneau d'extrémité
supérieur
x 2

○



Divider
·Diviseur
x 1

○

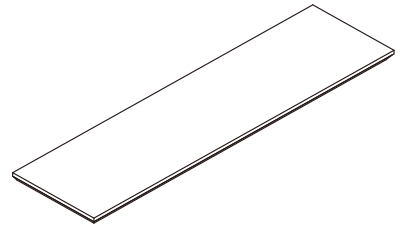

Top Panel
·Panneau du haut
x 1

○

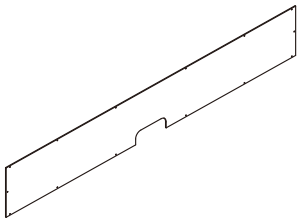

Back Center Panel
·Panneau central arrière
x 1

○

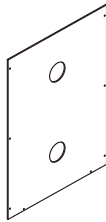

Back Panel
·Panneau arrière
x 2

○



Wood Stopper
·Bouchon en bois
x 1

○

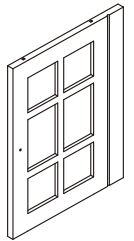

Door
·Porte
x 2

○

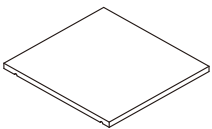

Shelf
·Étagère
x 2

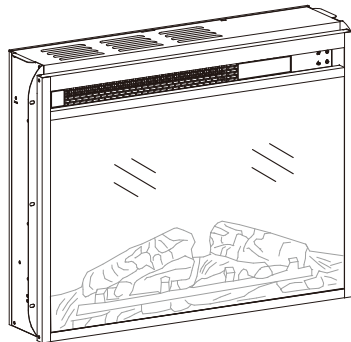

Fireplace
·Cheminée

Supplied Hardware · Matériel Fourni

1

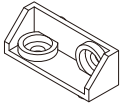

Connector
· Connecteur
x 16

2

M6 x 12mm



Bolt · Boulon
x 32

3

4mm



Allen Key
· Clé Allen
x 1

4

M6 x 35mm



Cam Bolt
· Boulon à came
x 30

5

Ø15 x 12mm



Cam Lock
· Verrouillage à came
x 30

6

Ø8 x 30mm

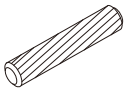

Wood Dowel
· Cheville en bois
x 34

7

M5 x 35mm

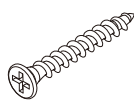

Screw · Vis
x 8

8



Washer
· Machine à laver
x 2

9

M3 x 15mm



Screw · Vis
x 8

10

1/4-20 x 5/8"



Foot Pad
x 2

11

Ø8 x 20mm



Wood Dowel
· Cheville en bois
x 2

12

M4 x 28mm

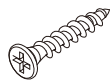

Screw · Vis
x 3

13

M3 x 15mm



Screw · Vis
x 30

14

M6 x 50mm

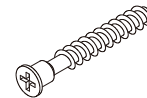

Bolt · Boulon
x 2

15

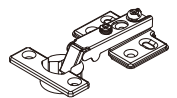

Hinge
· Charnière
x 4

16

M3.5 x 12mm



Screw · Vis
x 24

17



Door Handle
· Poignée de porte
x 2

18

M4 x 28mm



Bolt · Boulon
x 2

19

Ø5 x 16mm



Shelf Pin
· Goupille d'étagère
x 8

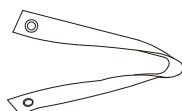

Fixing Kit
· Kit de fixation
x 2

Ø4 x 12mm



Ø4 x 25mm

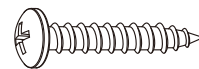

⚠ CAUTION! · ATTENTION!

This wall anchor is for solid concrete ONLY. DO NOT use them in drywall or wood studs.

· Cette ancre murale est UNIQUEMENT pour le béton solide. NE les utilisez PAS dans les cloisons sèches ou les montants en bois.

Step 1 · Étape 1

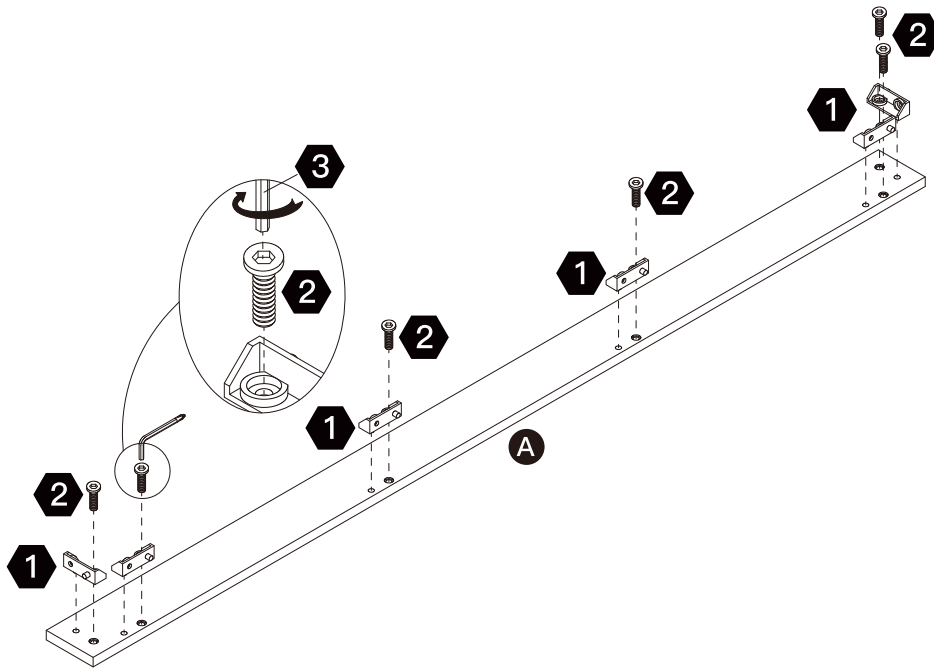

Step 2 · Étape 2

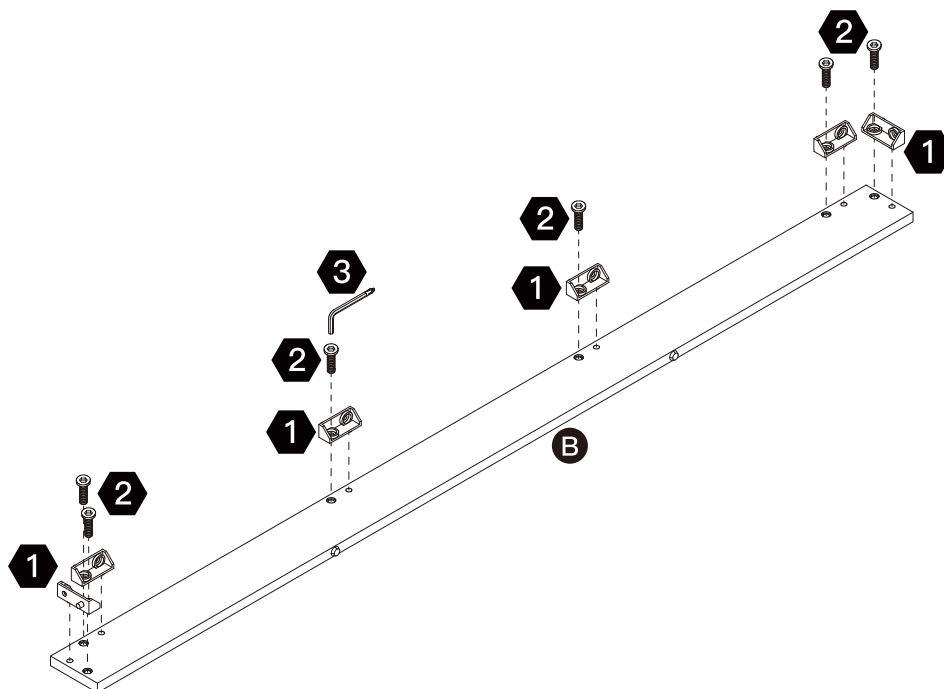

Step 3 · Étape 3

- 1**  x 4 **2**  M6 x 12mm x 4 **3**  4mm x 1

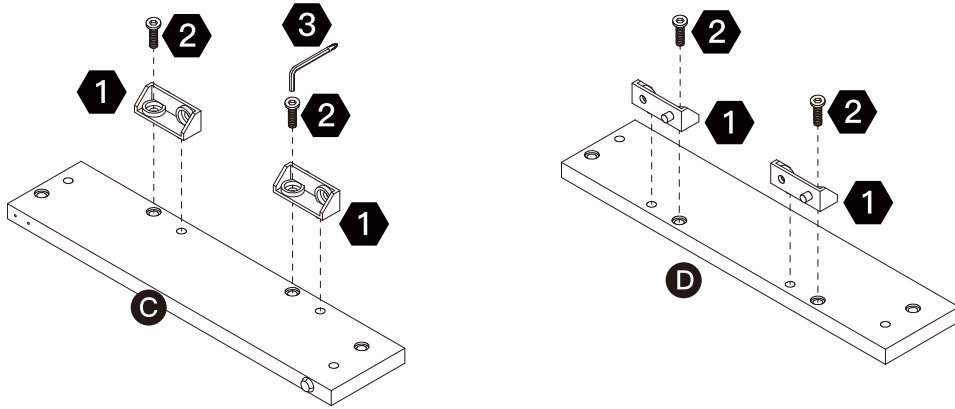

Step 4 · Étape 4

- 2**  M6 x 12mm x 4 **3**  4mm x 1

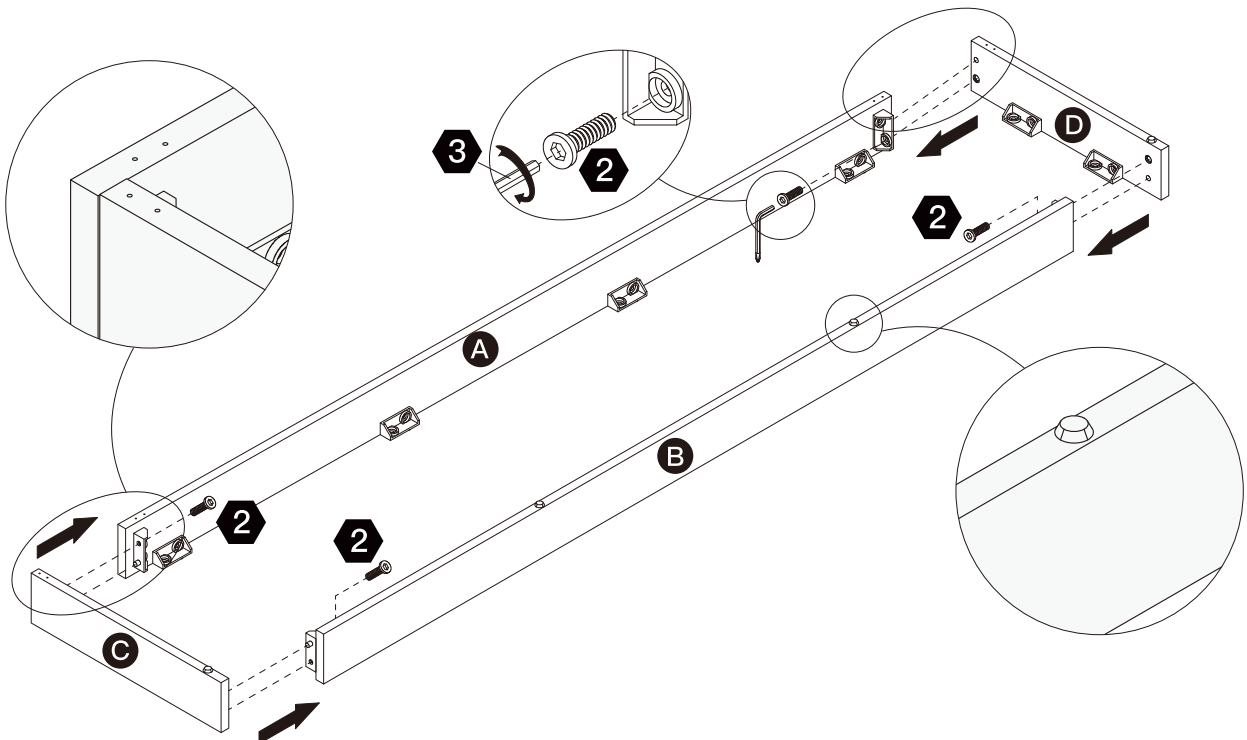

Step 5 · Étape 5

2  x 12 **3**  x 1

EN NOTE: Panel [A] and the round edge of panel [E] should be positioned on the same side.

FR REMARQUE : Le panneau [A] et le bord arrondi du panneau [E] doivent être positionnés du même côté.

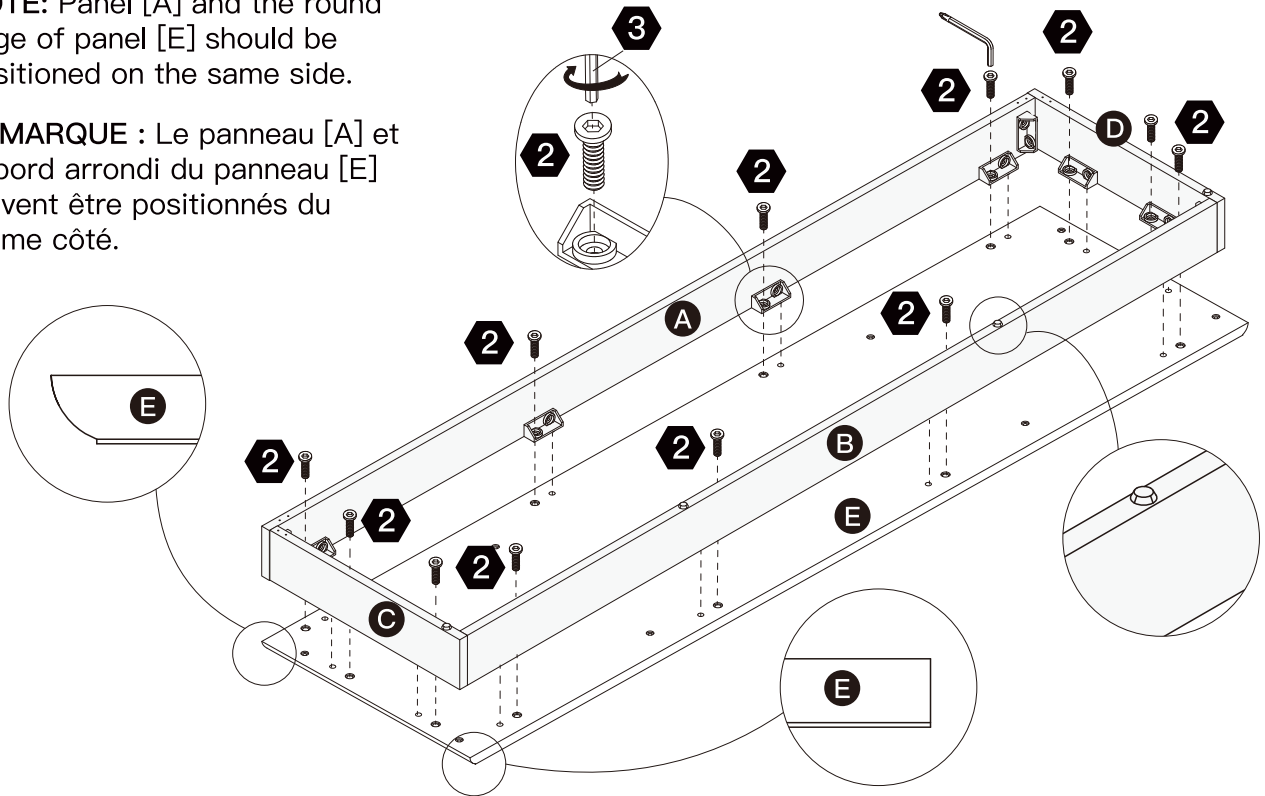

Step 6 · Étape 6

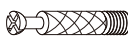
4  x 4

 (not included)
(non inclus)

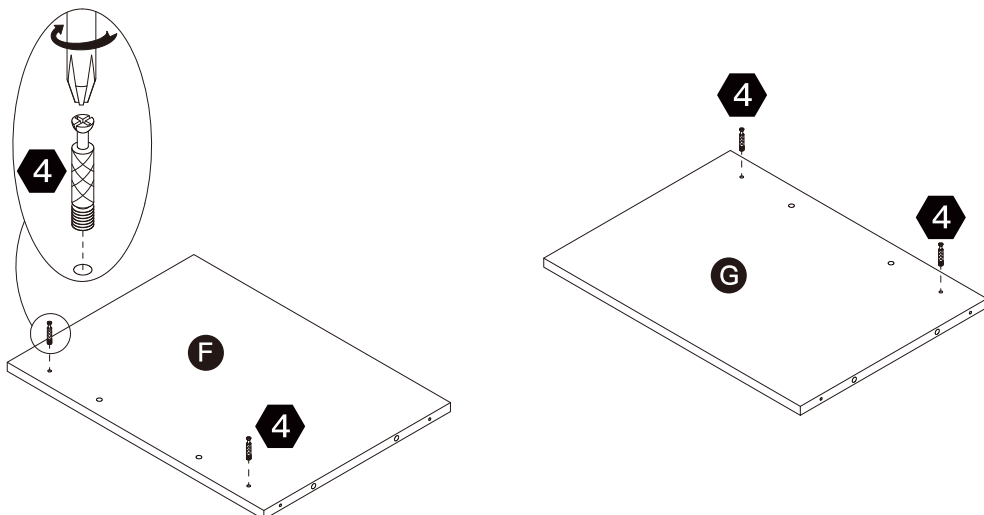

Step 7 · Étape 7

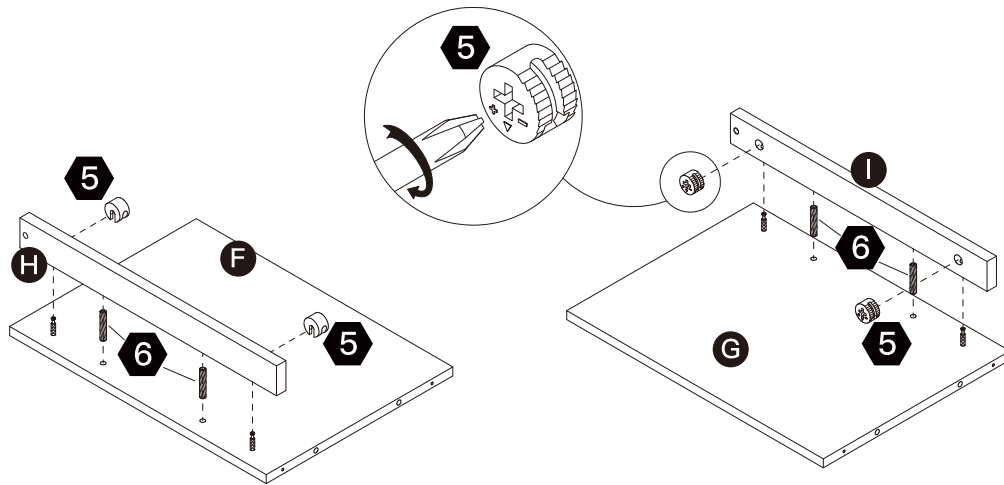
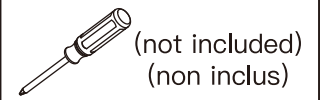

Step 8 · Étape 8

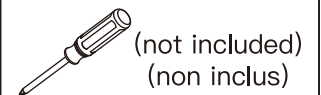

EN NOTE: The panel sides of [J] & [F] and [G] & [K] with cam lock holes should face each other.

FR REMARQUE : Les côtés des panneaux [J] et [F] et [G] et [K] avec des trous de verrouillage à came doivent se faire face.

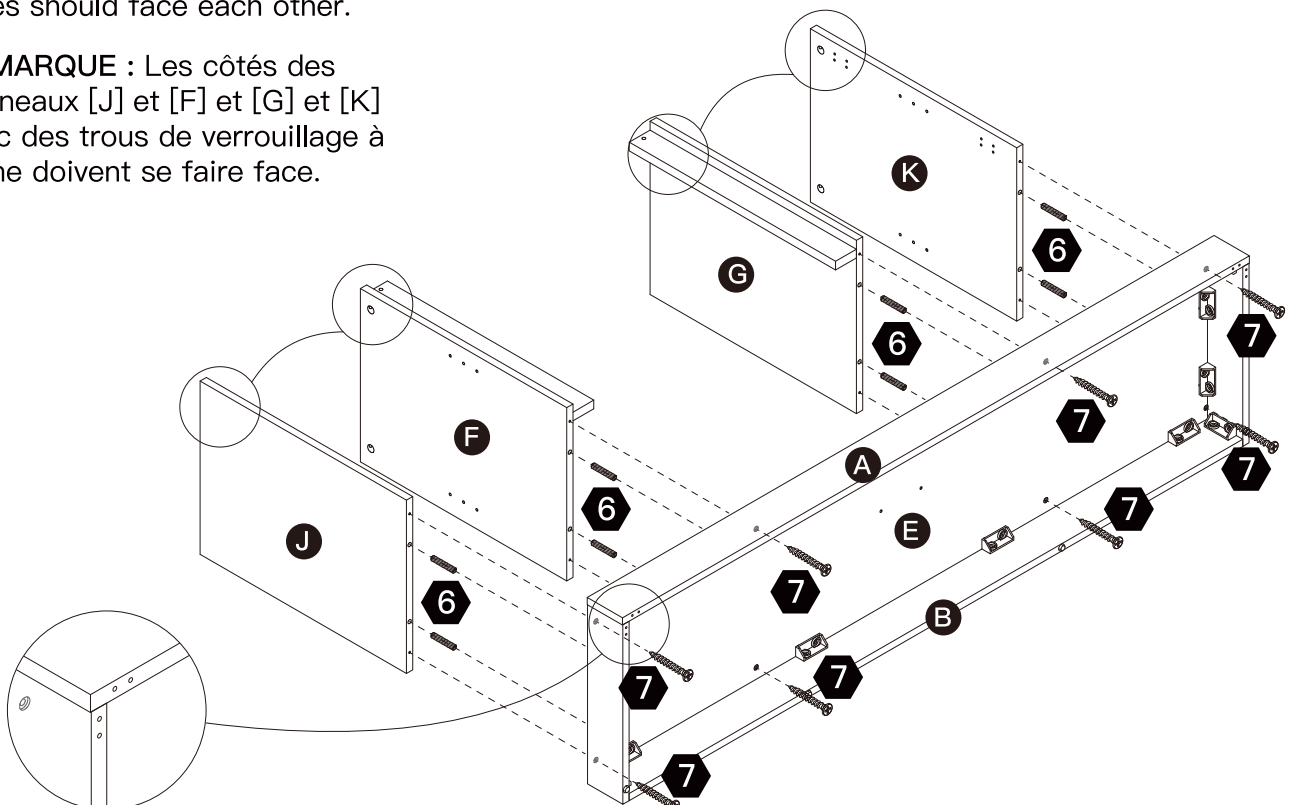

Step 9 · Étape 9

8  x 2

9  x 8
M3 x 15mm

 (not included)
(non inclus)

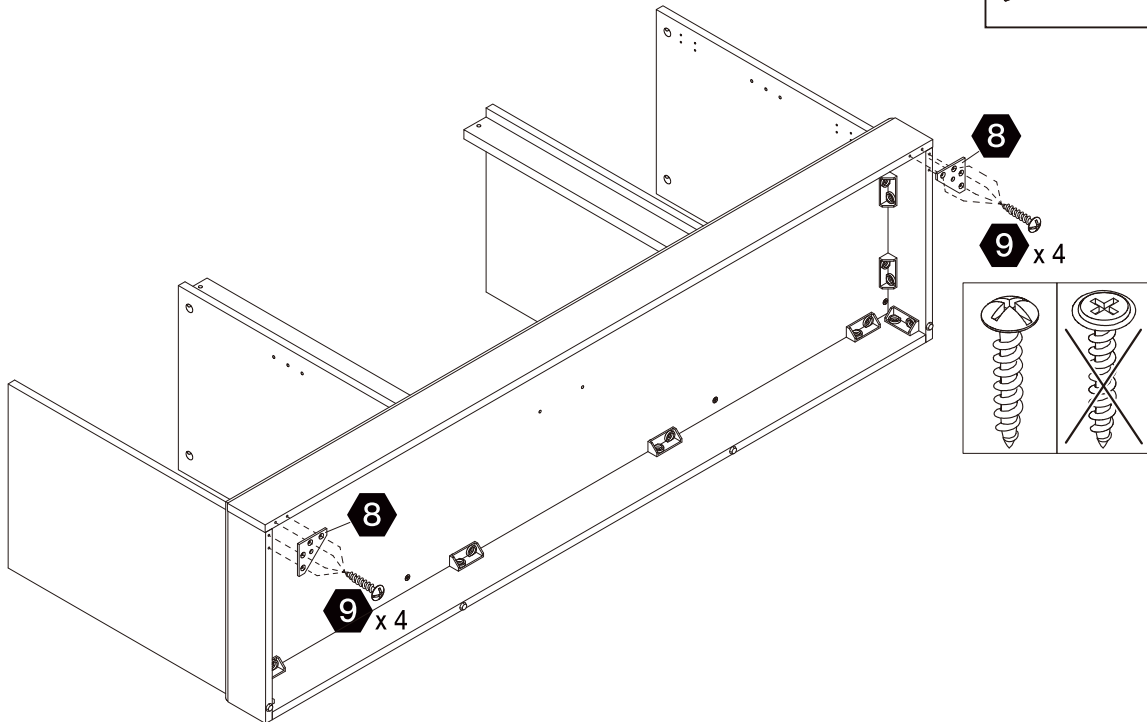

Step 10 · Étape 10

10  x 2
1/4-20 x 5/8"

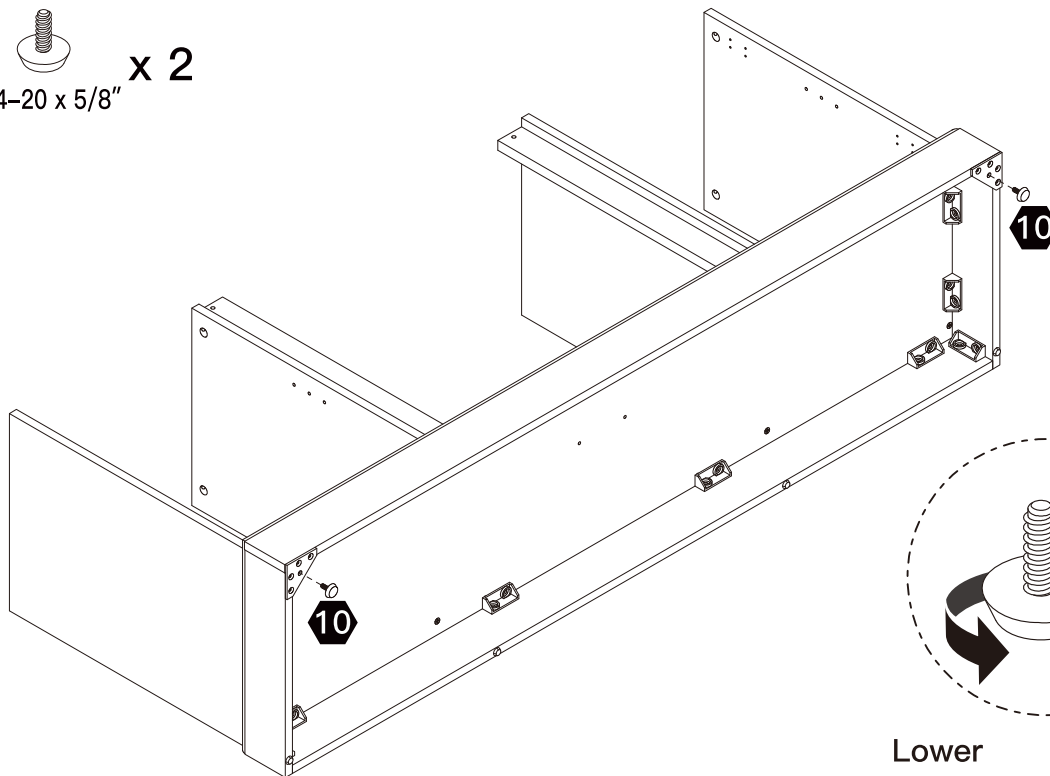

Lower · Inférieur Raise · Augmenter

·NOTE: Raise the front corners slightly taller than the back to help prevent your TV from tipping forward.
·REMARQUE : Soulevez les coins avant légèrement plus haut que l'arrière pour éviter que votre téléviseur ne bascule vers l'avant.

Step 11 · Étape 11

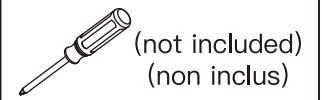

Step 12 · Étape 12

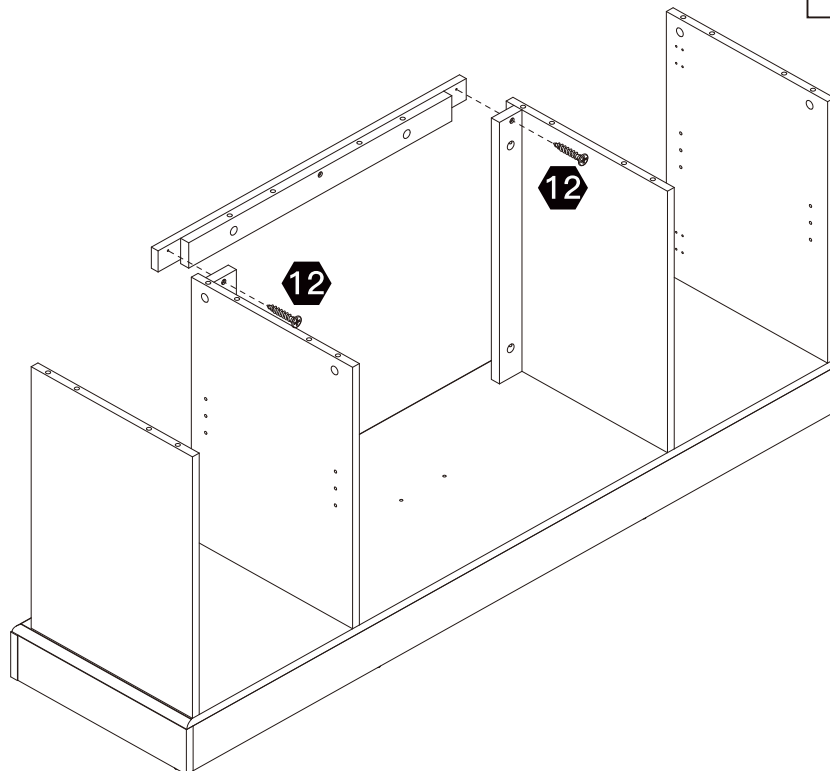
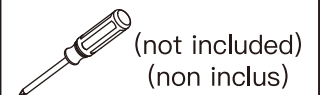

Step 13 · Étape 13

4  M6 x 35mm **x 10**

 (not included)
(non inclus)

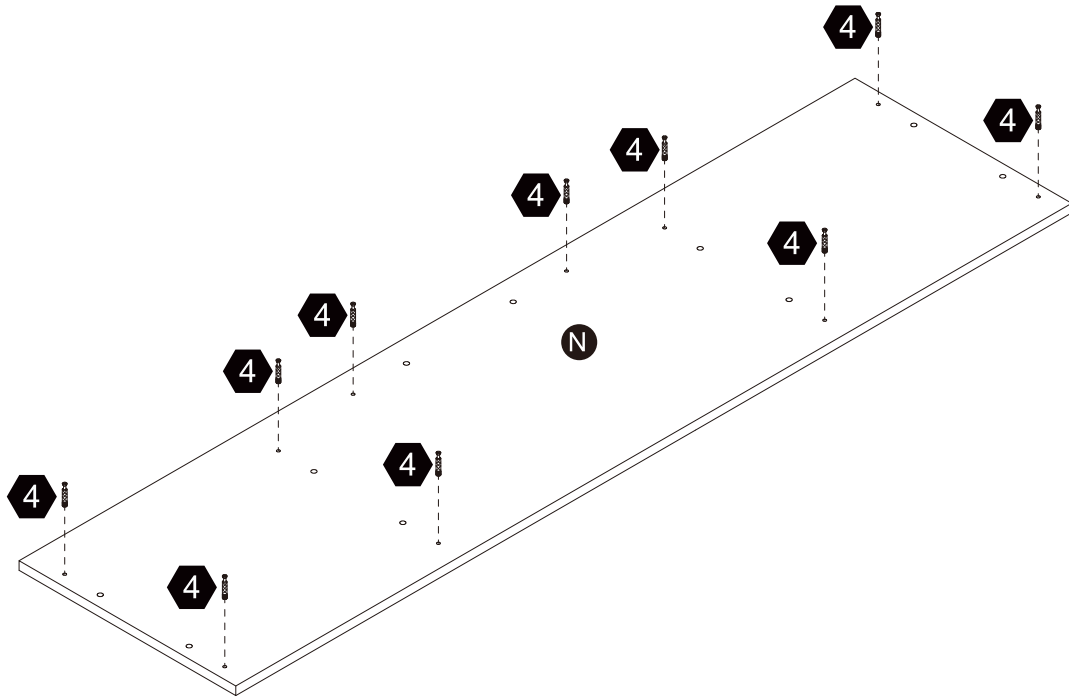

Step 14 · Étape 14

5  **x 10**
Ø15 x 12mm

6  **x 10**
Ø8 x 30mm

 (not included)
(non inclus)

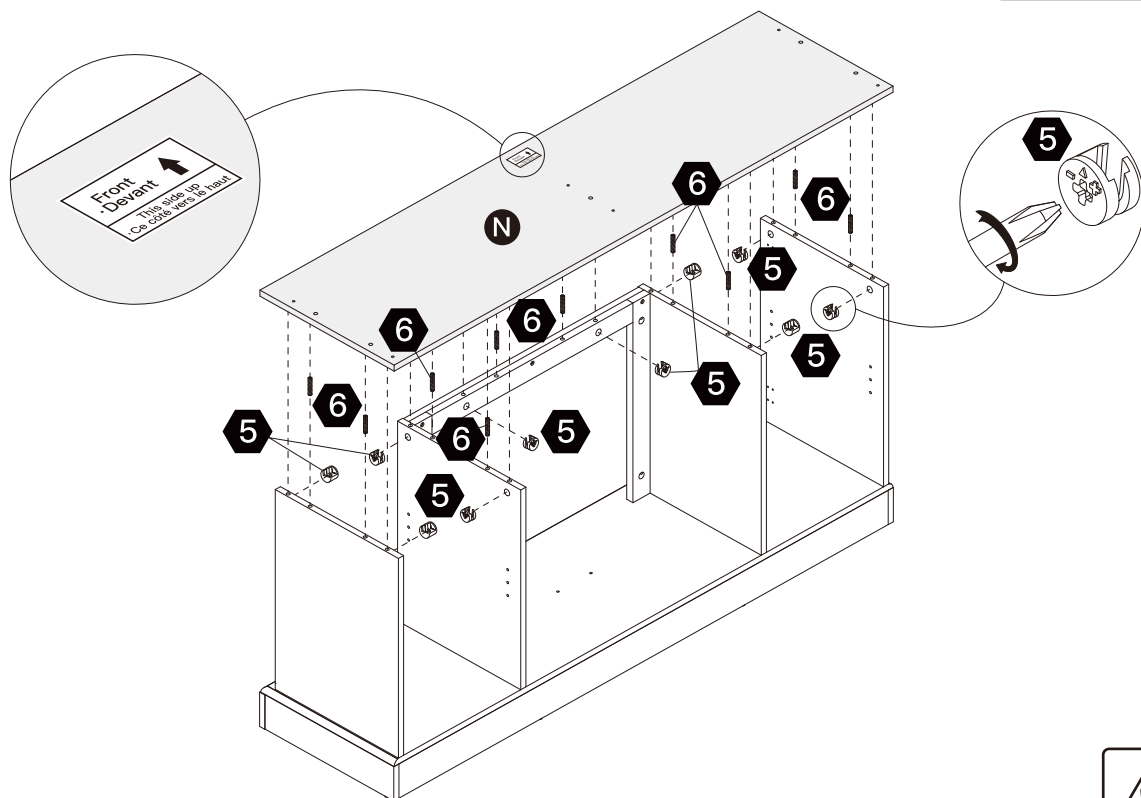

Step 15 · Étape 15

4  x 6
M6 x 35mm

6  x 5
Ø8 x 30mm

 (not included)
(non inclus)

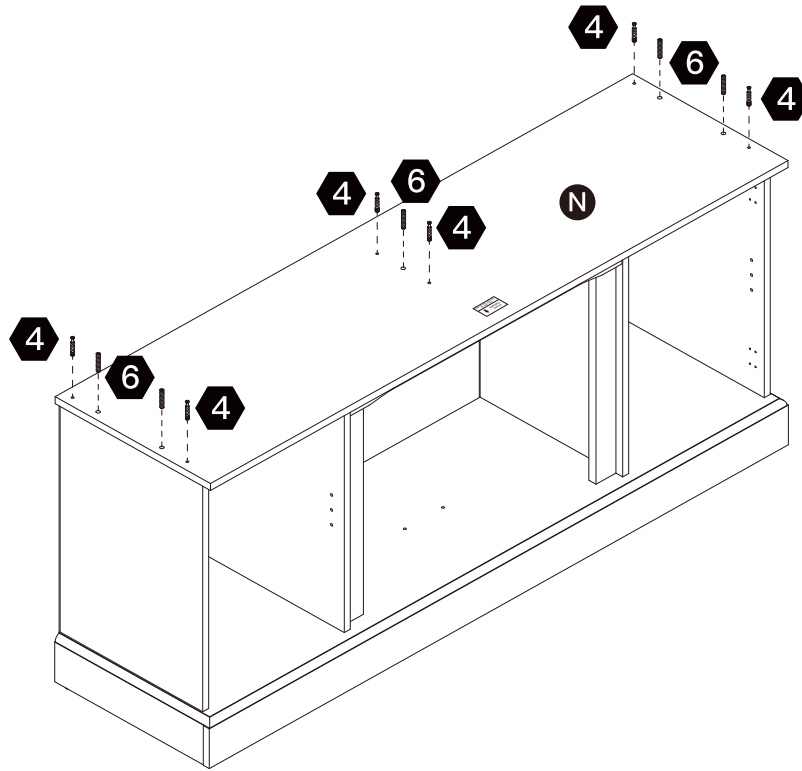

Step 16 · Étape 16

4  x 4
M6 x 35mm

 (not included)
(non inclus)

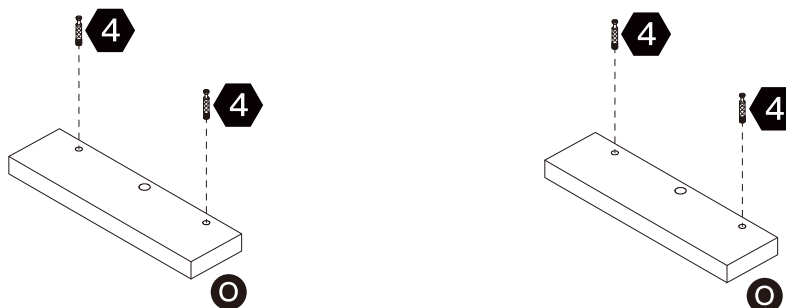

Step 17 · Étape 17

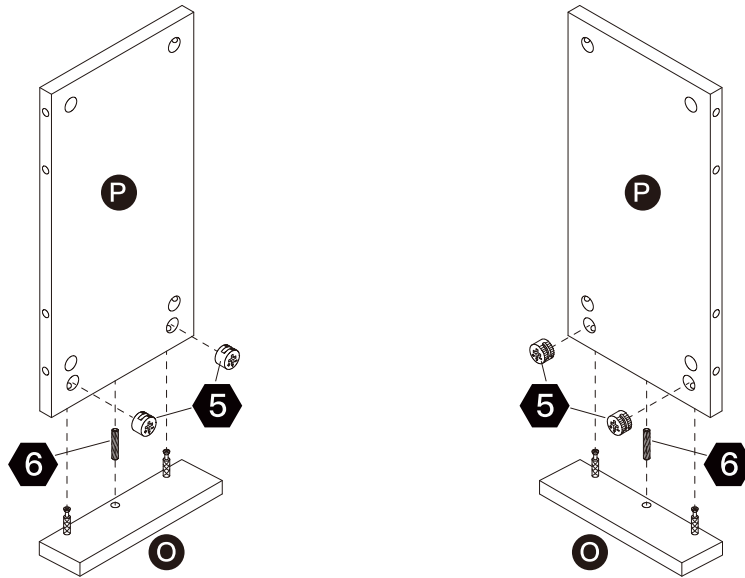
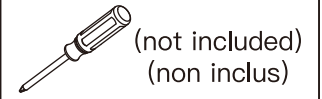

Step 18 · Étape 18

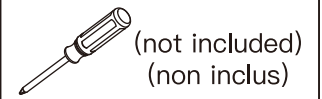
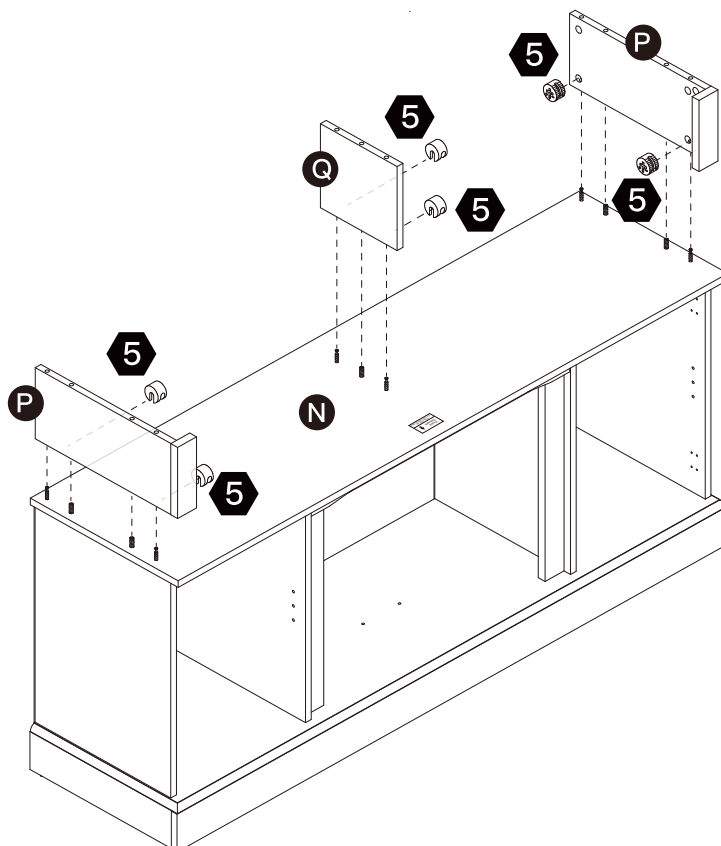

Step 19 · Étape 19

4  x 6
M6 x 35mm

 (not included)
(non inclus)

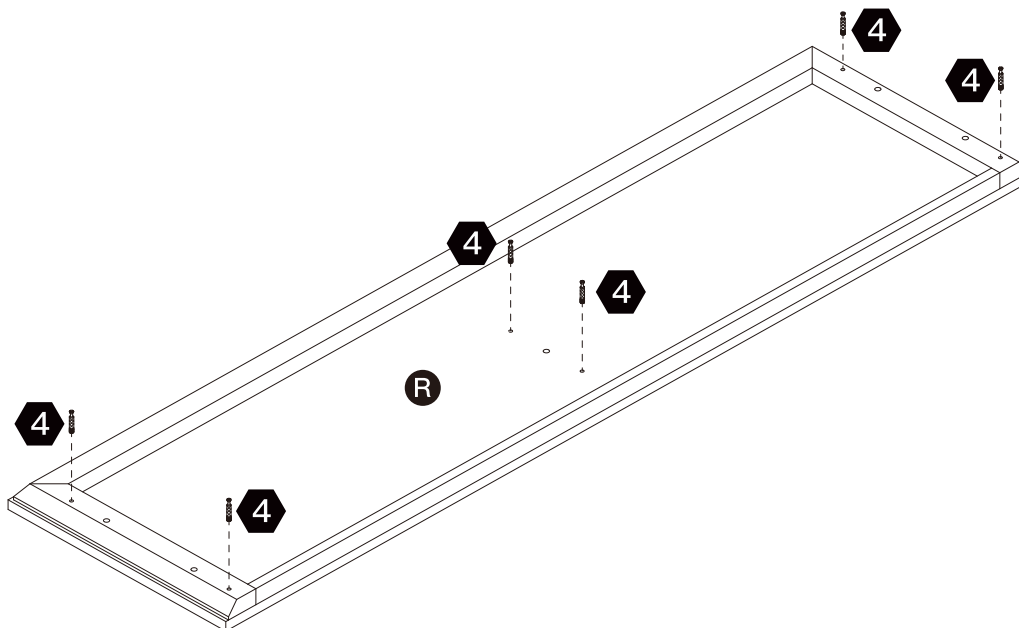

Step 20 · Étape 20

5  x 6
Ø15 x 12mm

6  x 5
Ø8 x 30mm

 (not included)
(non inclus)

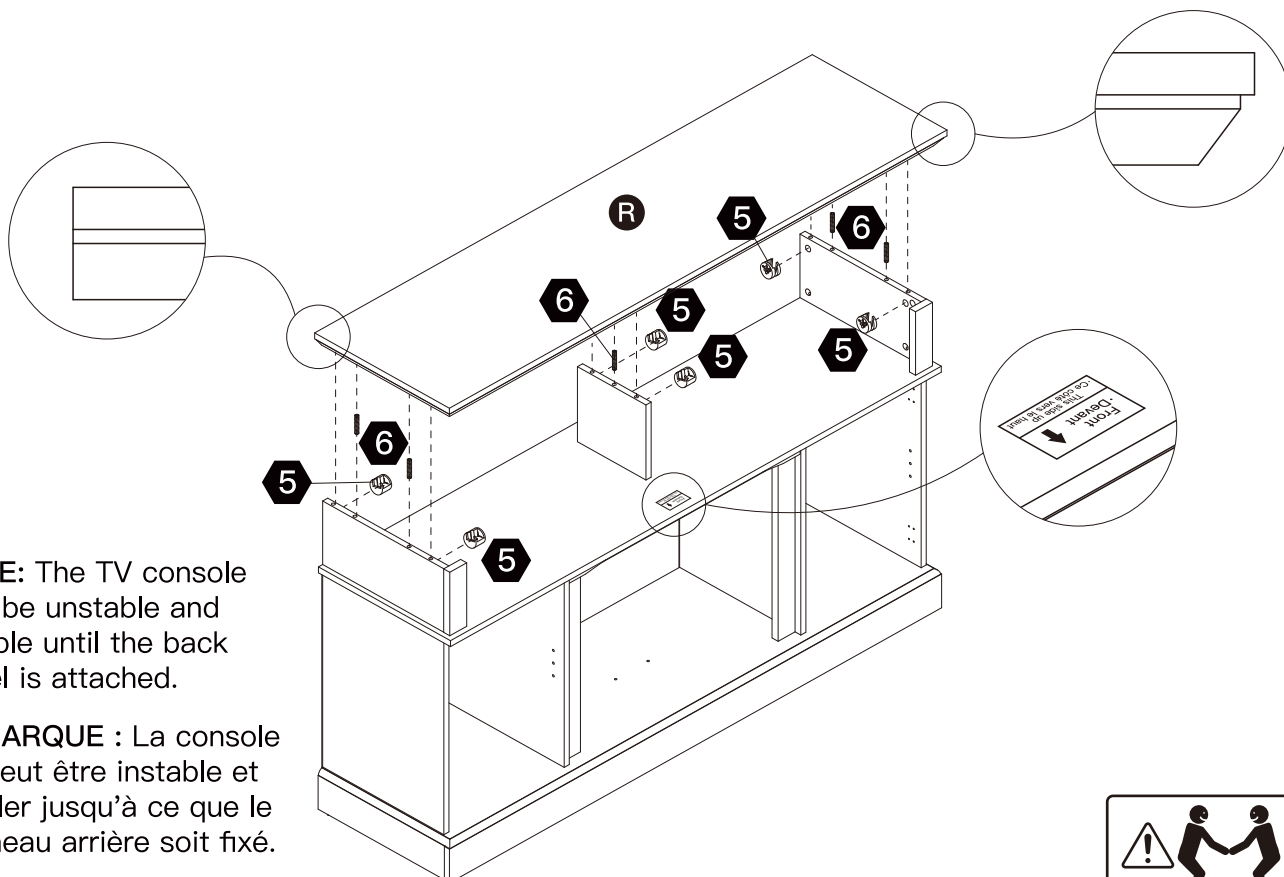



EN NOTE: The TV console may be unstable and wobble until the back panel is attached.

FR REMARQUE : La console TV peut être instable et vaciller jusqu'à ce que le panneau arrière soit fixé.



Step 21 · Étape 21

13  x 14
M3 x 15mm

 (not included)
(non inclus)

EN **Tip:** There are only 2 pilot holes on the top panel for the screws [13]. Attach the back panel [S] to the top panel [R] first using the 2 pilot holes. Loosely thread all of the other screws [13] into place before fully tightening one by one.

FR **Astuce :** Il n'y a que 2 avant-trous sur le panneau supérieur pour les vis [13]. Fixez d'abord le panneau arrière [S] au panneau supérieur [R] à l'aide des 2 avant-trous. Vissez sans serrer toutes les autres vis [13] en place avant de serrer complètement une par une.

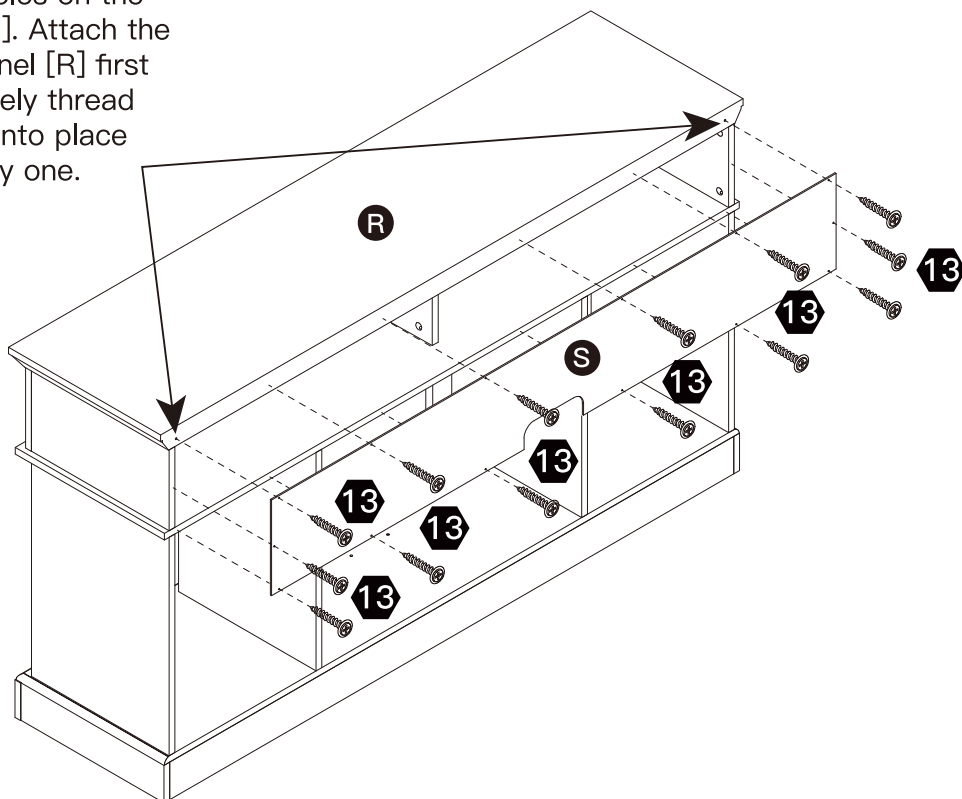

Step 22 · Étape 22

13  x 16
M3 x 15mm

 (not included)
(non inclus)

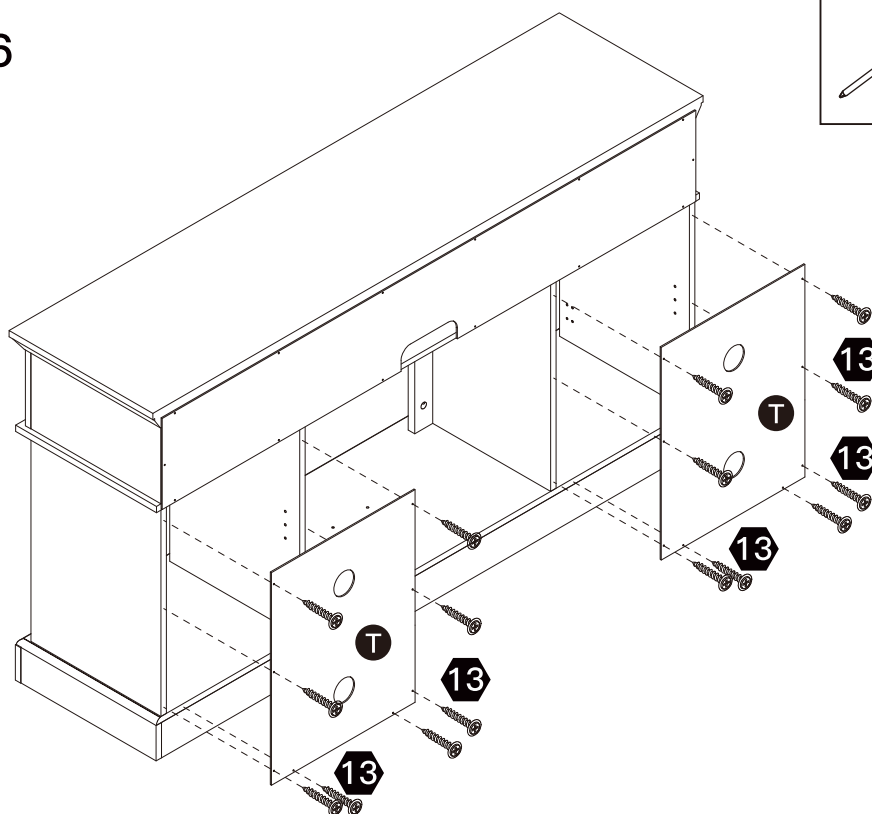

Step 23 · Étape 23

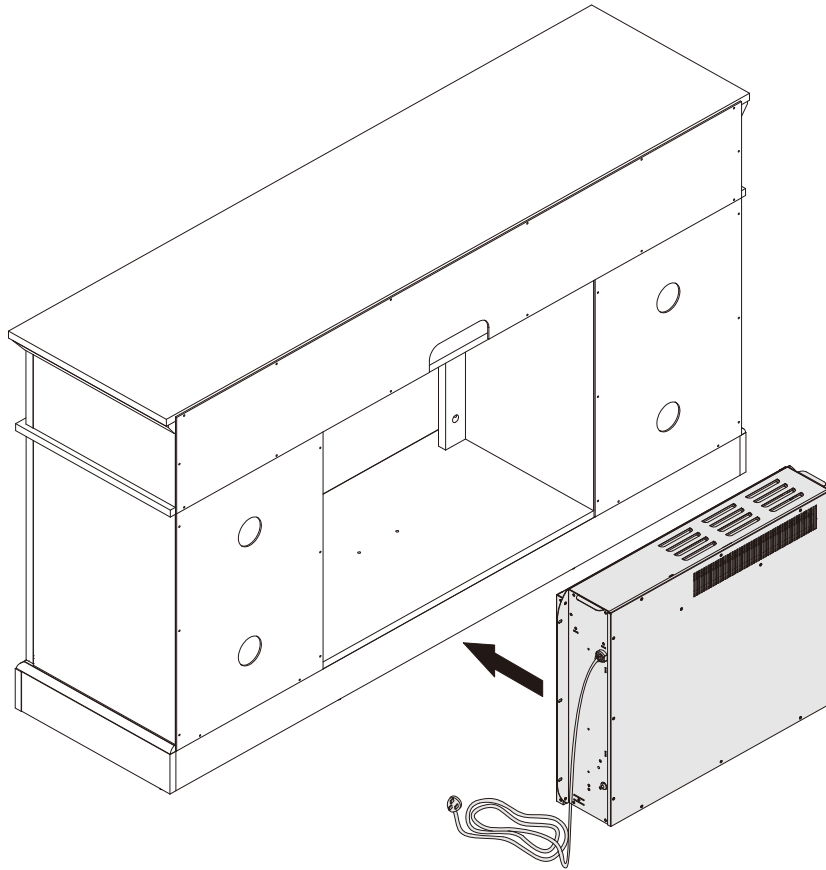

Step 24 · Étape 24

14  **x 2**
M6 x 50mm

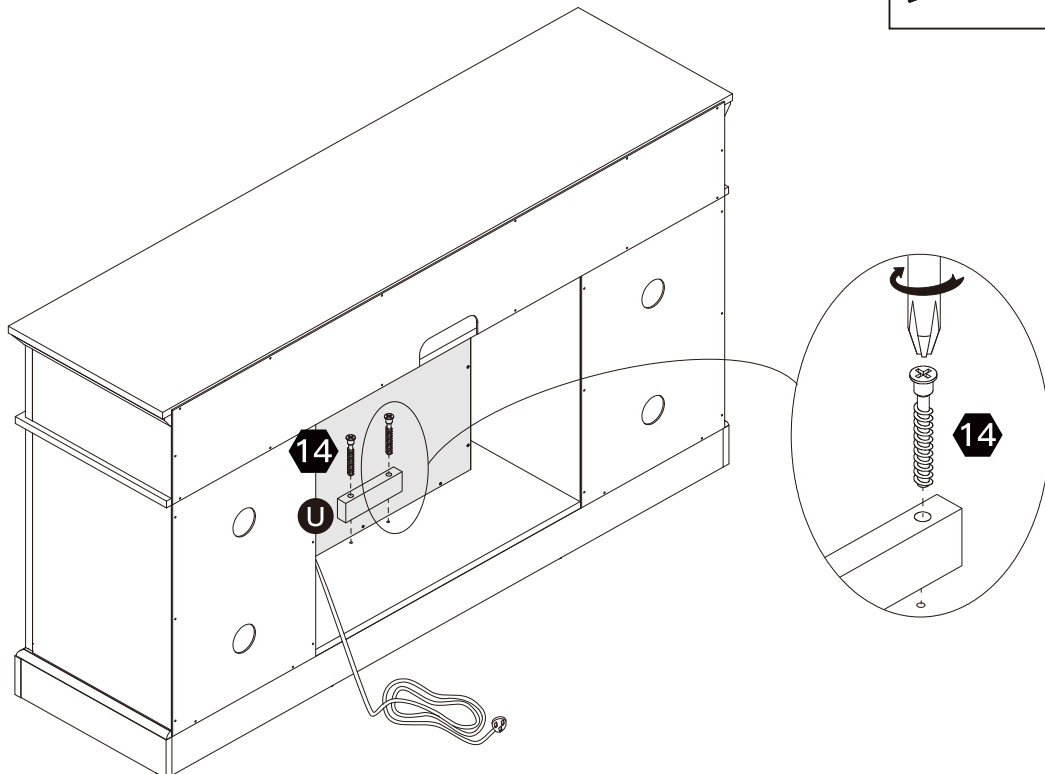
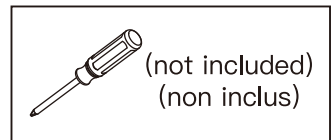

Step 25 · Étape 25

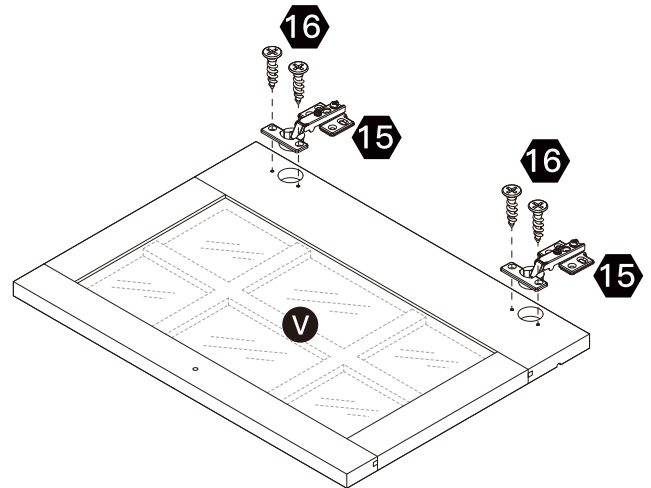
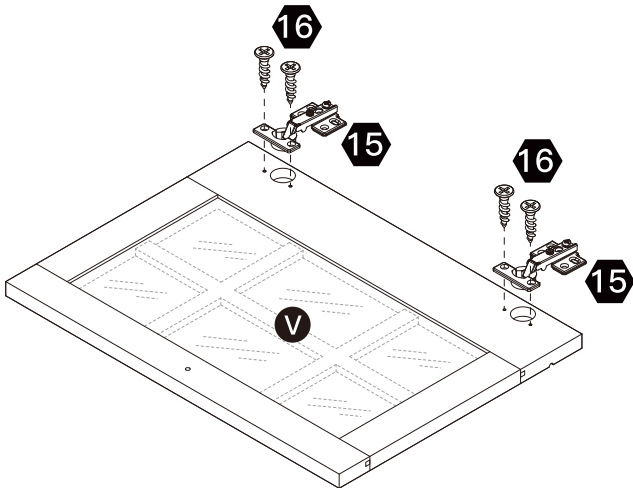
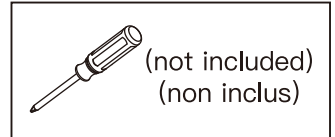

Step 26 · Étape 26

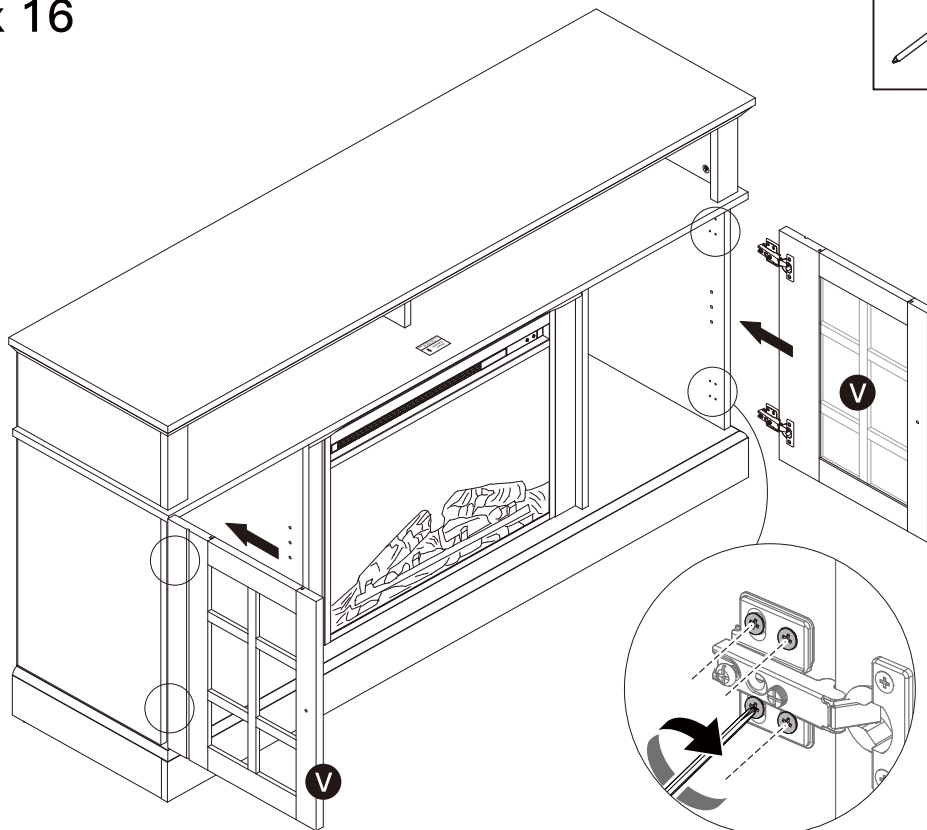
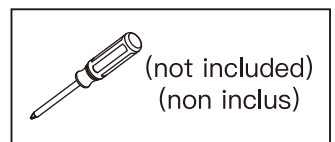

Step 27 · Étape 27

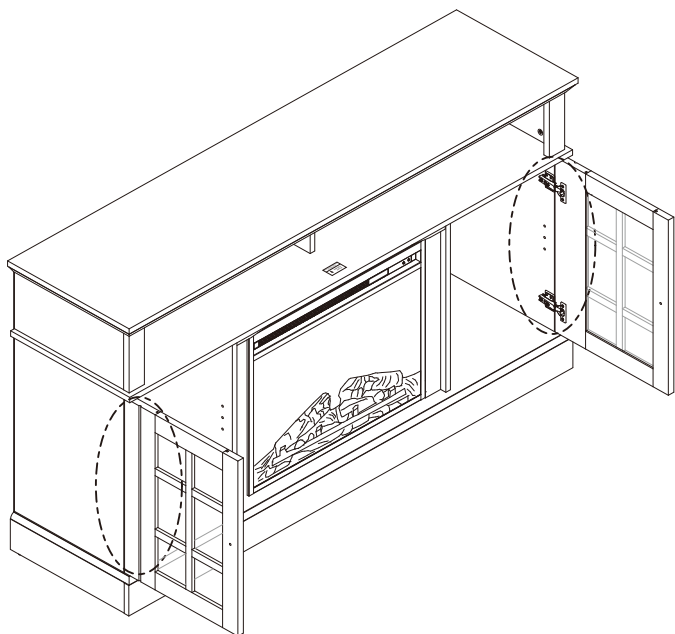

EN The doors may go out of alignment during shipping. Open and close the doors to make sure they are aligned correctly. If you find that the doors need to be adjusted, turn the appropriate screw, as illustrated. The hinges are adjustable in three directions for perfect alignment.

FR Les portes peuvent être désalignées pendant le transport. Ouvrez et fermez les portes pour vous assurer qu'elles sont correctement alignées. Si vous constatez que les portes doivent être ajustées, tournez la vis appropriée, comme illustré. Les charnières sont réglables dans trois directions pour un alignement parfait.

To adjust door up or down

· Pour ajuster la porte vers le haut ou vers le bas

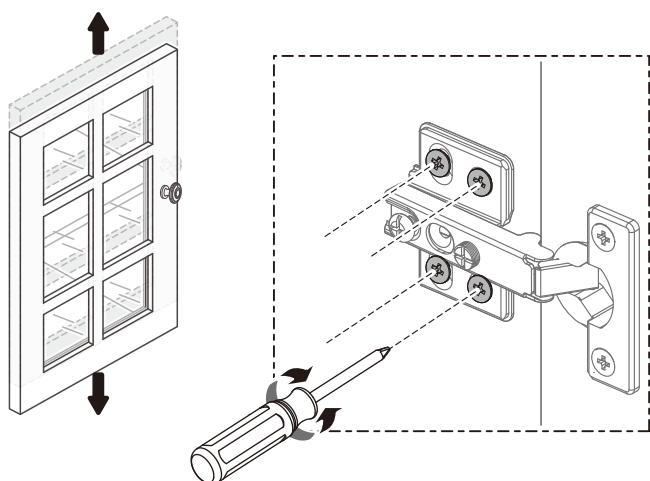

To adjust door forward or backward

· Pour ajuster la porte vers l'avant ou vers l'arrière

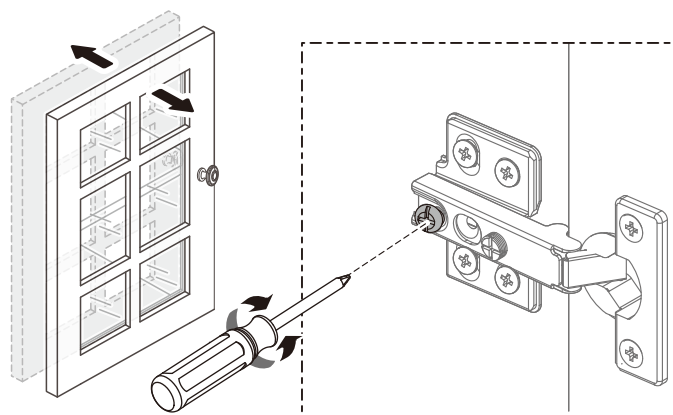

To adjust door left or right

· Pour ajuster la porte vers la gauche ou vers la droite

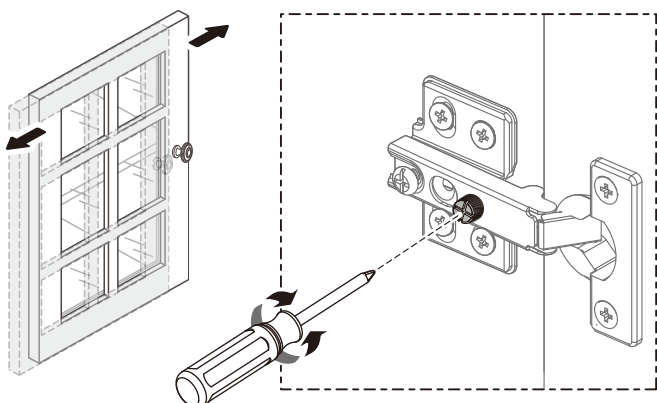

EN Turn the set screw clockwise to narrow the gap between the door and the side panel. Turn the set screw counterclockwise to enlarge the gap between the door and the side panel.

FR Tournez la vis de réglage dans le sens des aiguilles d'une montre pour réduire l'écart entre la porte et le panneau latéral. Tournez la vis de réglage dans le sens contraire des aiguilles d'une montre pour agrandir l'écart entre la porte et le panneau latéral.

Step 28 · Étape 28

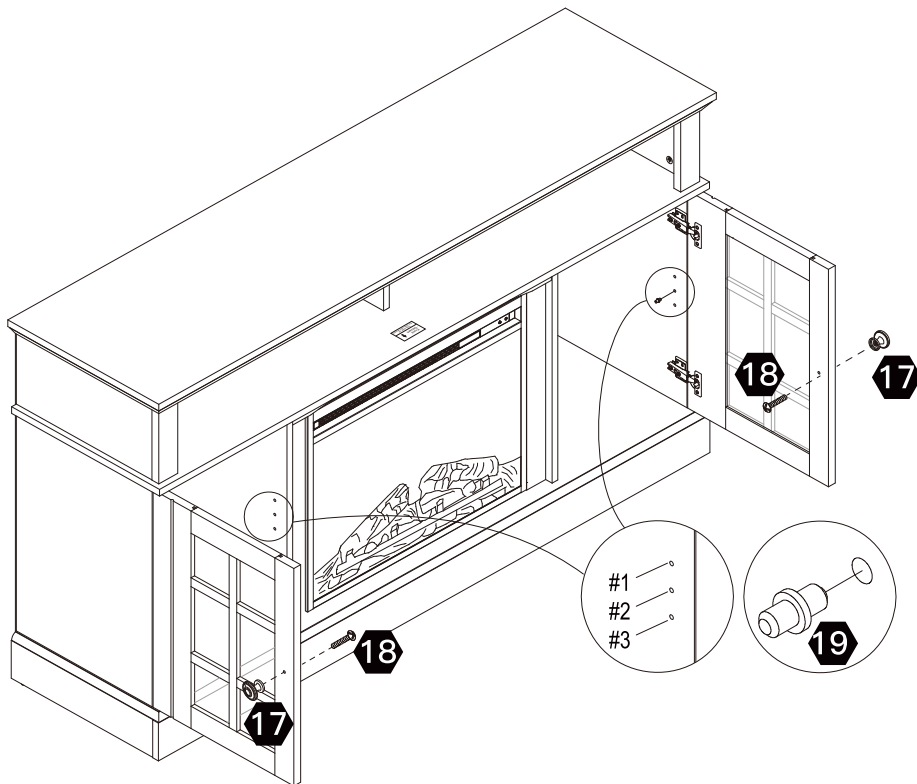
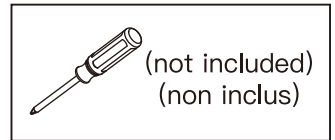

EN NOTE: Shelves can be installed at three different heights.

FR REMARQUE : Les étagères peuvent être installées à trois hauteurs différentes.

Step 29 · Étape 29

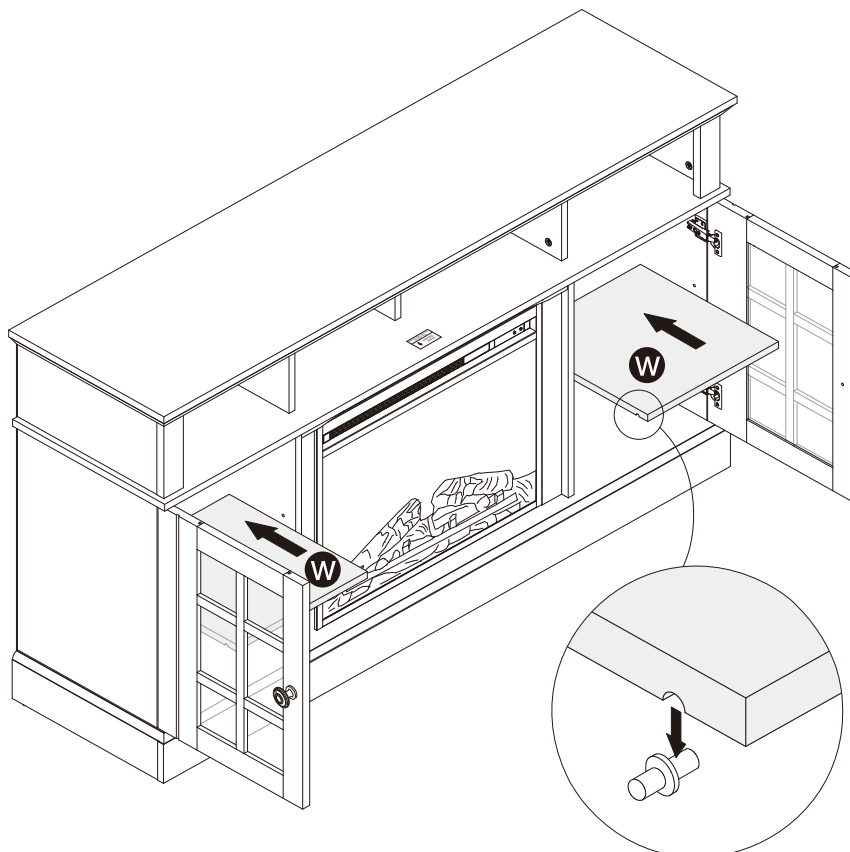

Step 30 · Étape 30

· Tools Needed
(Not Included)
· Outils nécessaires
(Non inclus)

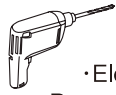

· Electric Drill
· Perceuse électrique



· Phillips Screwdriver
· Tournevis Phillips

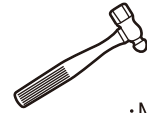

· Hammer
· Marteau-piqueur

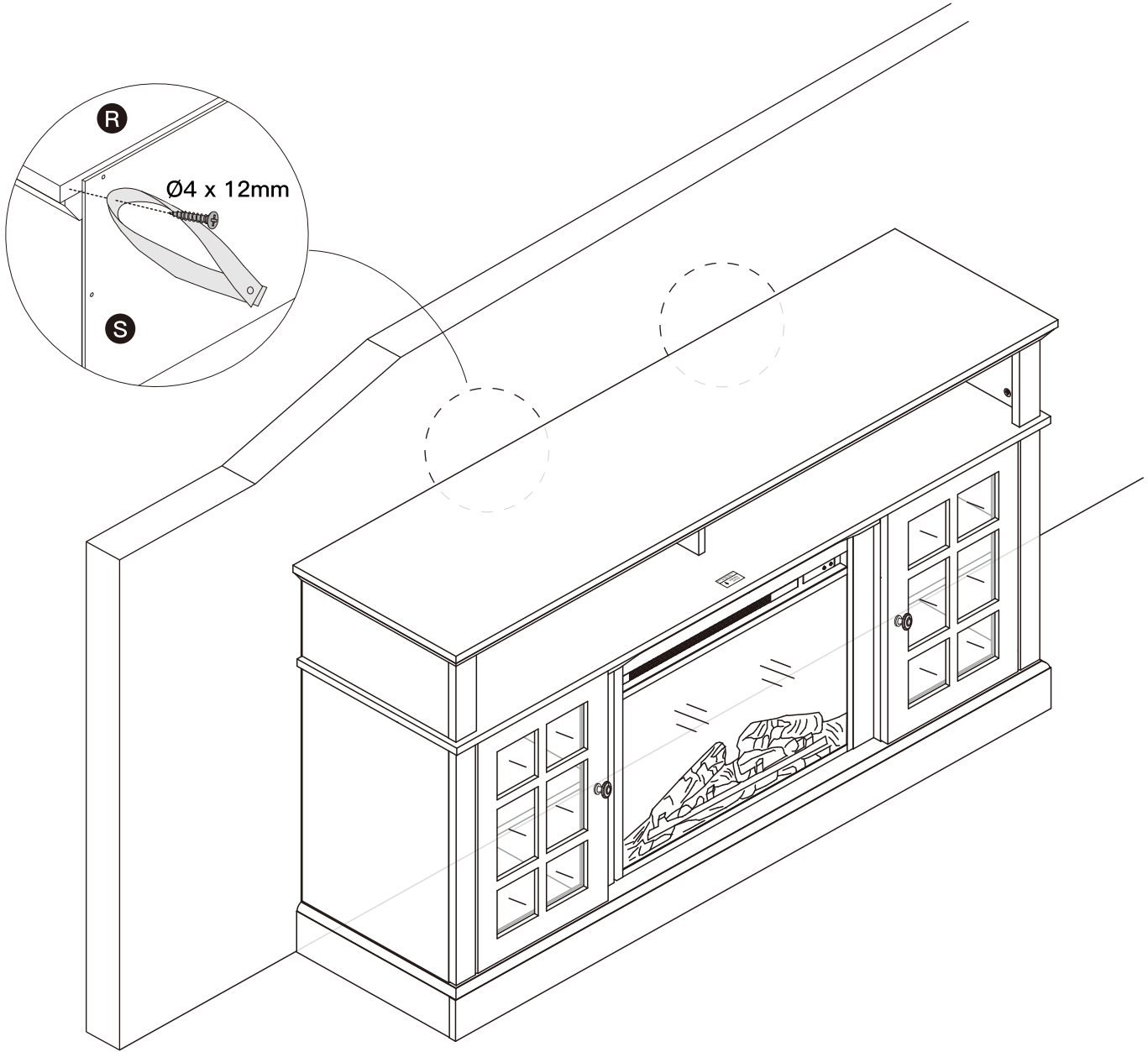

For Wood Studs · Pour les montants en bois

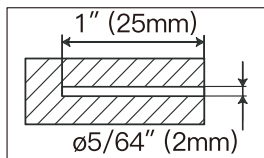
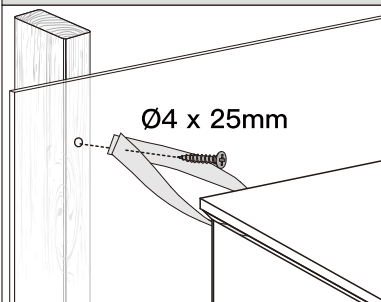
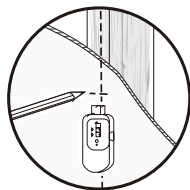
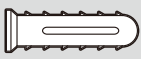

For Solid Concrete · Pour béton massif

