



ASSEMBLY INSTRUCTION

DESCRIPTION: KING UPHOLSTERED HEADBOARD



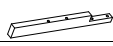

Thank you for purchasing this quality product. Be sure to check all packing material carefully for small parts, which may have come loose inside the carton during shipment. Identify and count all parts and compare with the parts list below.

HARDWARE LIST

PARTS LIST

NO.	SKETCH	DESCRIPTION	Q'TY
A		Headboard	1
B		Left Leg	1
C		Right Leg	1
D		Stretcher	1

HARDWARE LIST

NO.	DRAWING	HARDWARE	Q'TY
1		Bolt Ø5/16"*50mm	4
2		Bolt Ø5/16"*40mm	2
3		Spring Washer Ø5/16"*12mm	6
4		Flat Washer Ø5/16"*19mm	6
5		Allen Key 4mm	1

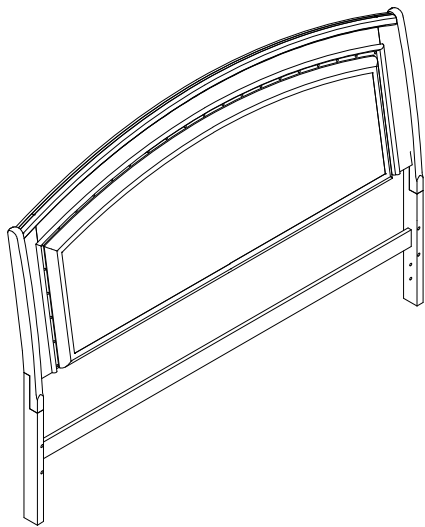

Complete Assembly

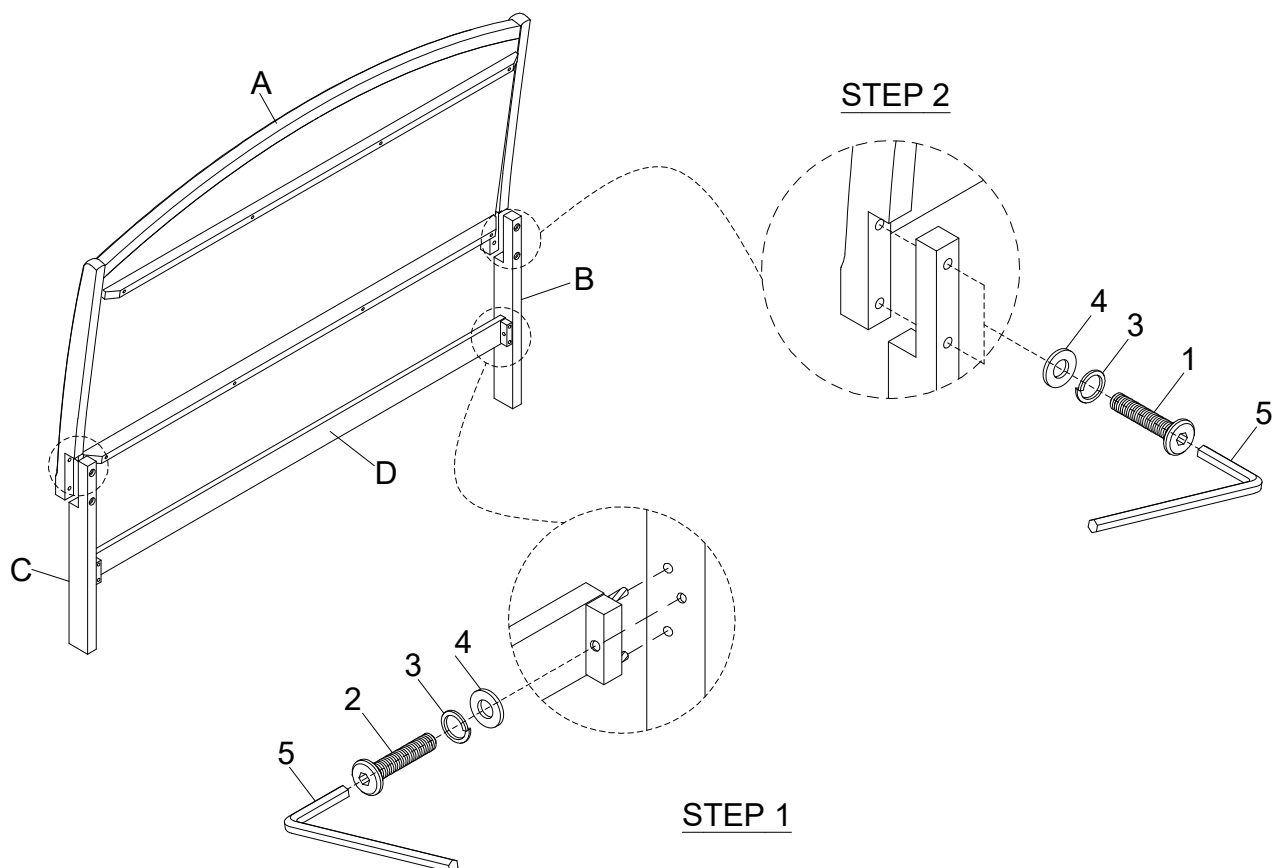

ASSEMBLY INSTRUCTION

KING UPHOLSTERED HEADBOARD DESCRIPTION: KING STORAGE FOOTBOARD STORAGE BED RAILS

Thank you for purchasing this quality product. Be sure to check all packing material carefully for small parts, which may have come loose inside the carton during shipment. Identify and count all parts and compare with the parts list below.

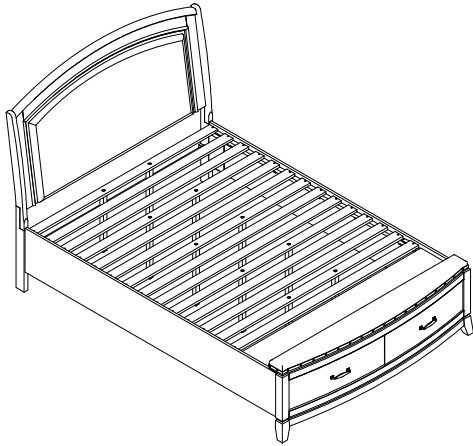

Complete Assembly

PARTS LIST

NO.	DRAWING	DESCRIPTION	Q'TY
A		Headboard	1
B		Footboard	1
C		Left Side rails	1
D		Right Side rails	1
E		Slat roll	1 Set
F		Support leg for slat	10
G		Support leg for footboard	3

HARDWARE LIST

NO.	DRAWING	HARDWARE	Q'TY
1		Bolt Ø5/16**30mm	6
2		Spring Washer Ø1/4"	6
3		Flat Washer Ø5/16**19mm	6
4		Allen Key 4mm	1
5		Hanger Bolt Ø5/16**18*110mm	8
6		Curved washer Ø5/16*25*16mm	8
7		Double hex nut Ø5/16*12mm	8
8		Allen Wrench 12*90mm	1
9		Screw #8*25mm	10

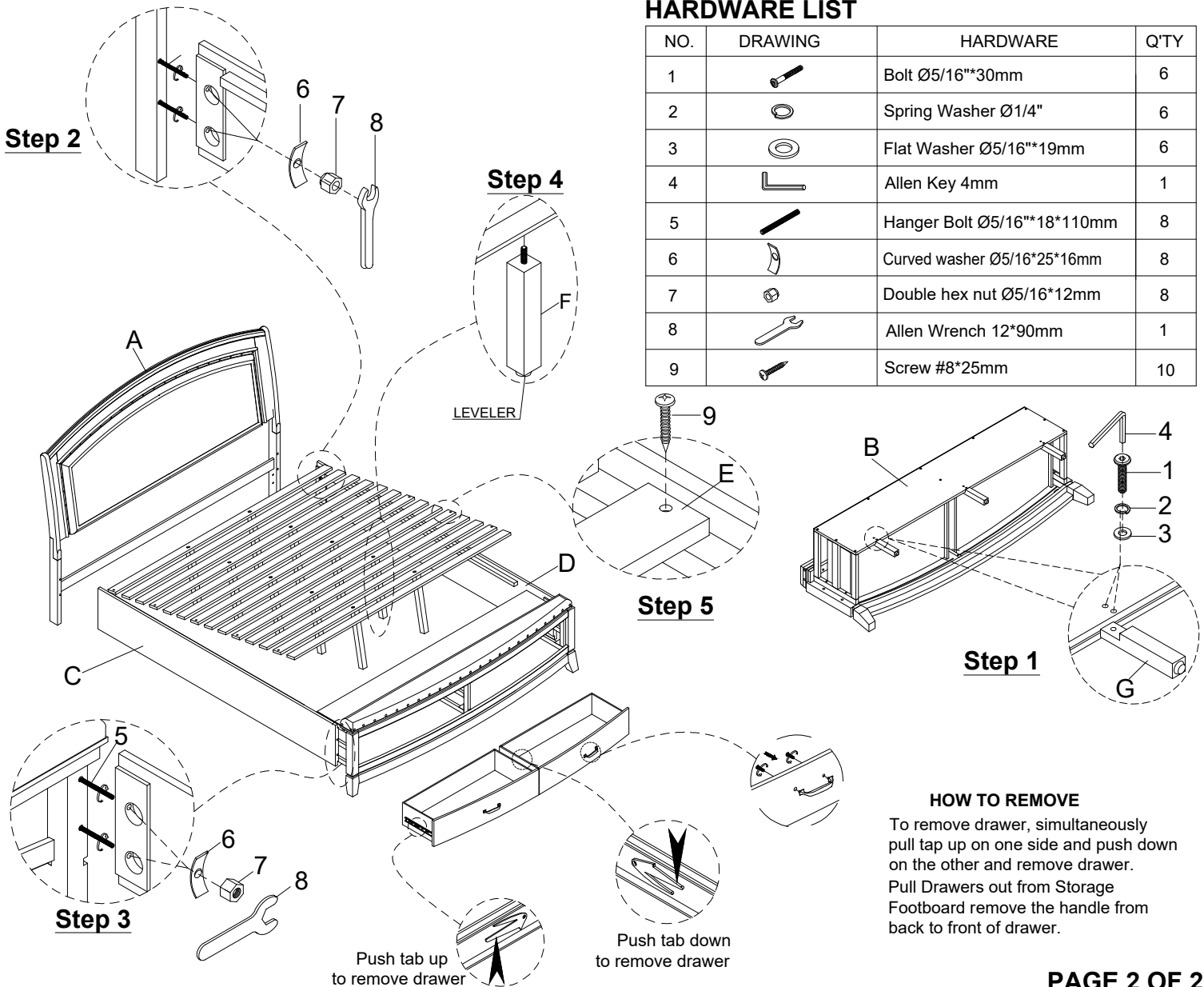

HOW TO REMOVE

To remove drawer, simultaneously pull tap up on one side and push down on the other and remove drawer. Pull Drawers out from Storage Footboard remove the handle from back to front of drawer.