

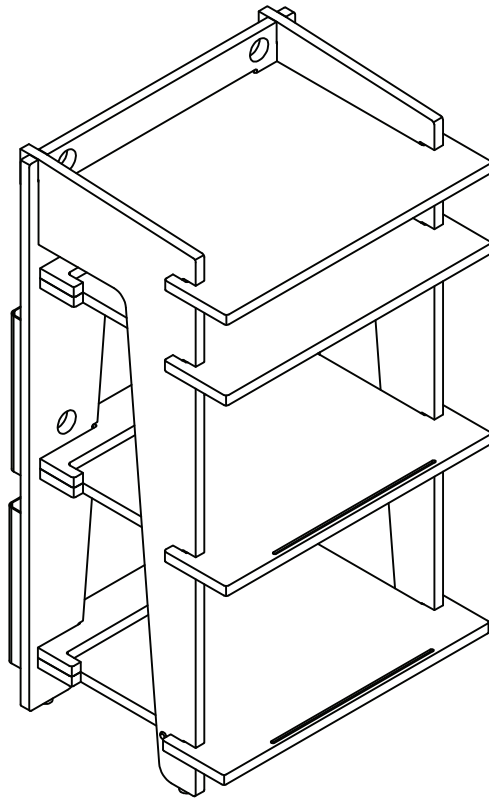

Turntable Stand

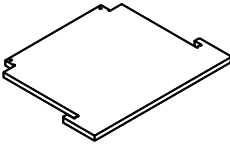
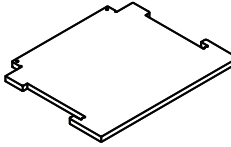
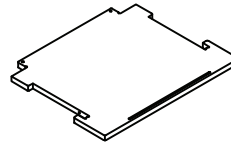
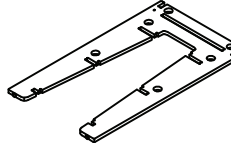
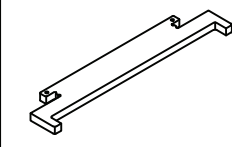
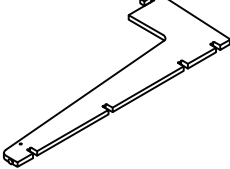
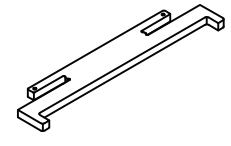
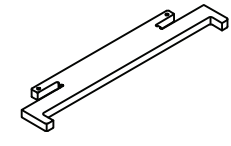

PART LIST

<p>A</p> 	<p>B</p> 	<p>C</p> 	<p>D</p> 	<p>E</p> 
<p>Top Panel 1 PC</p>	<p>Middle Shelf 1 PC</p>	<p>Lower Shelf 2 PCS</p>	<p>Back Panel 1 PC</p>	<p>Lower Bar 1 PC</p>
<p>F</p> 	<p>G</p> 	<p>H</p> 	<p>I</p> 	
<p>Side Panel 2 PCS</p>	<p>Upper Bar 1 PC</p>	<p>Middle Bar 1 PC</p>	<p>Plastic Wire Box 2 PCS</p>	

HARDWARE LIST

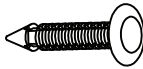
<p>#1</p> 
<p>Plastic Pin 12 PCS (Extra 1)</p>

Step 1. Attach side panels (part F) to back panel (part D) using plastic pins (part #1).

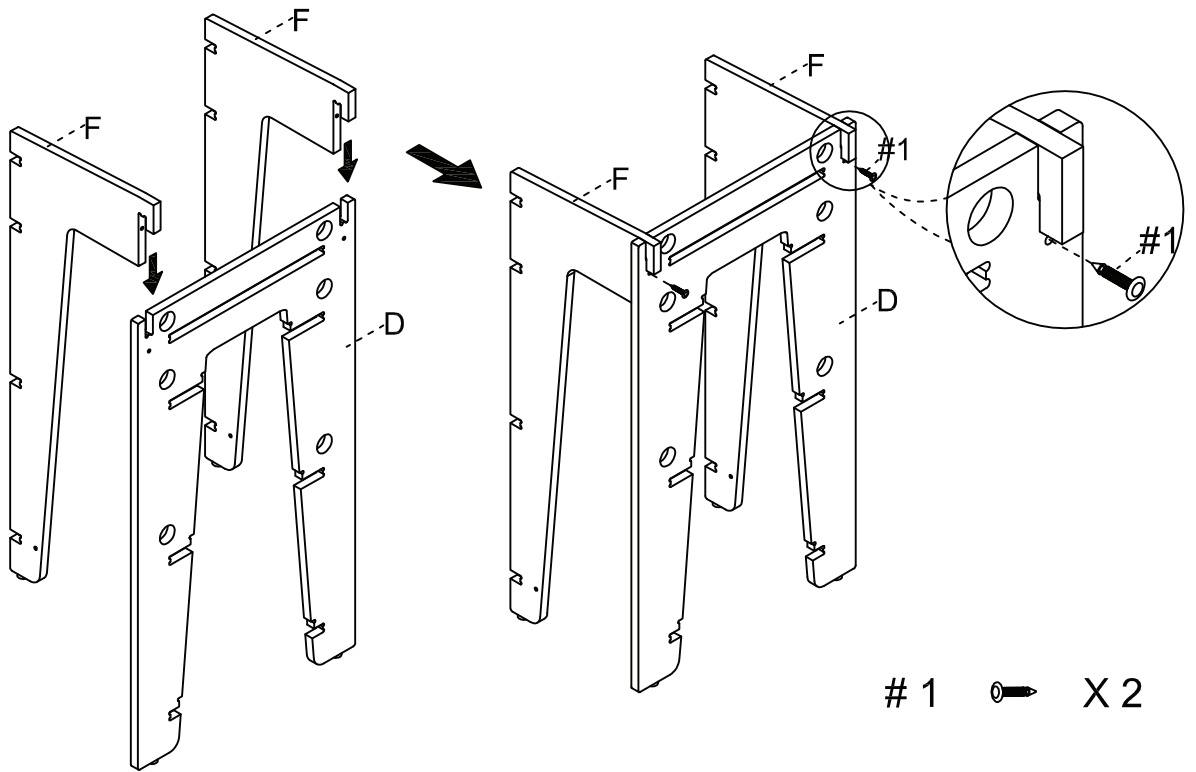

Step 2. Attach top panel (part A) to assembled unit (parts D & F) using plastic pins (part #1).

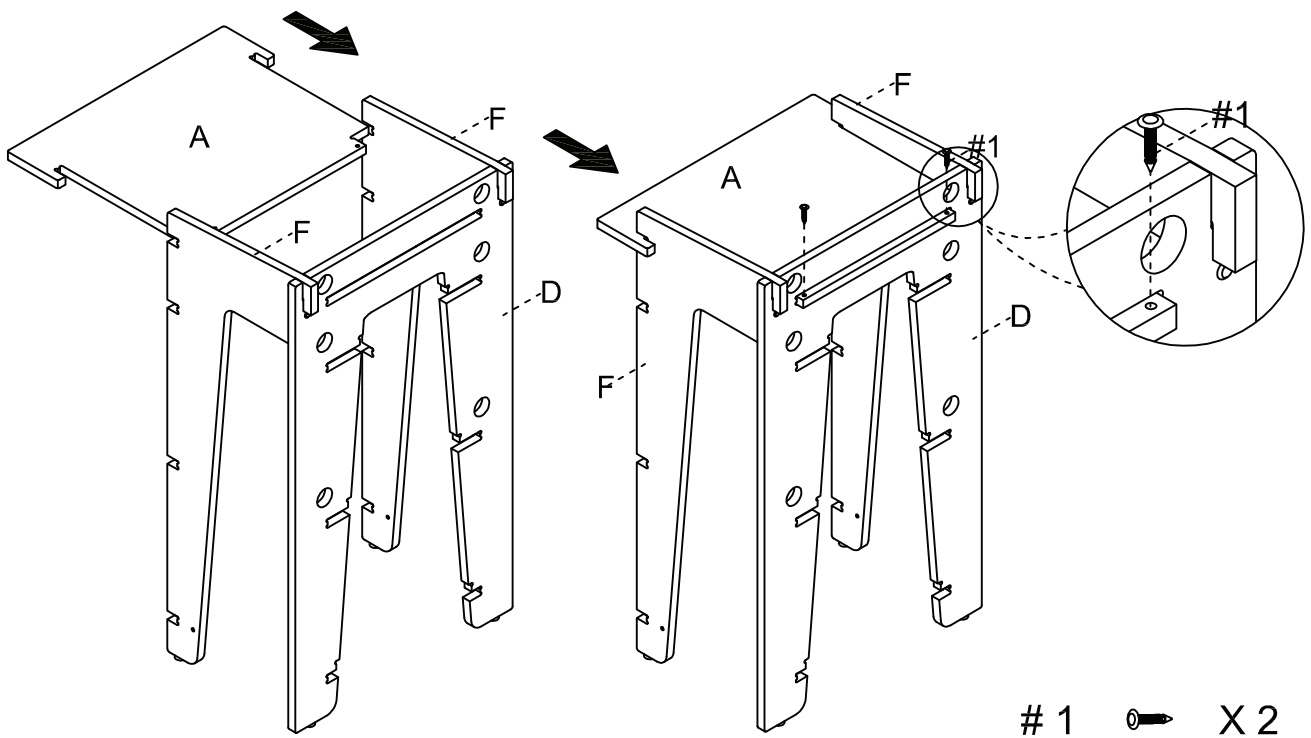

Step 3. Carefully turn unit upside down on a soft flat surface, such as carpet, as shown below. Attach upper bar (part G) to back panel (part D).

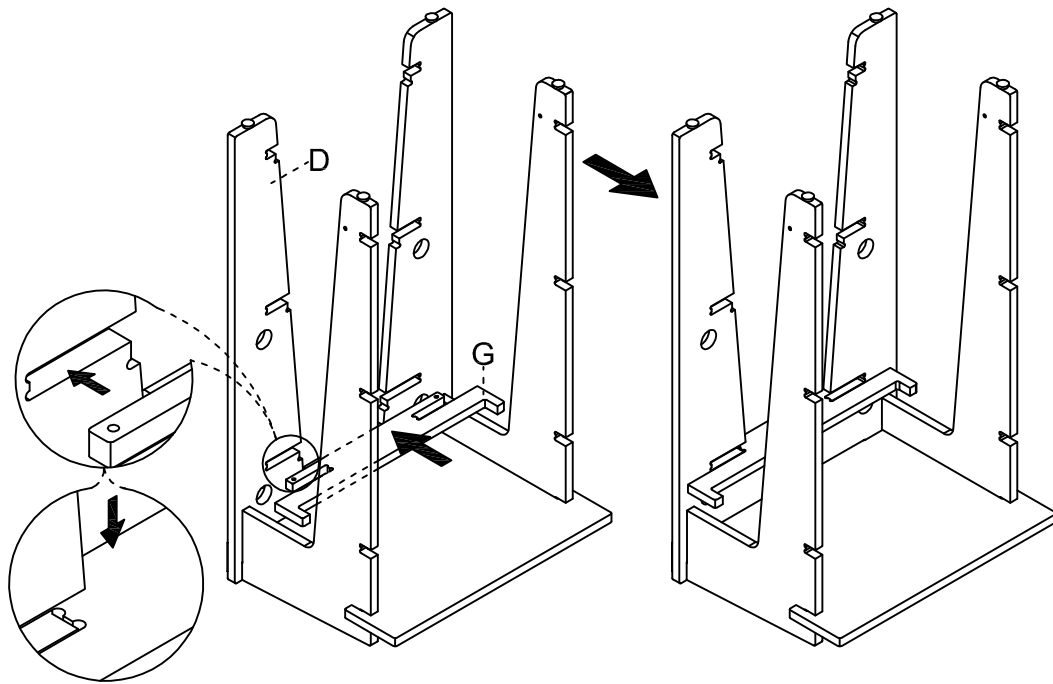

Step 4. Attach middle shelf (part B) to assembled unit (parts D, F & G).

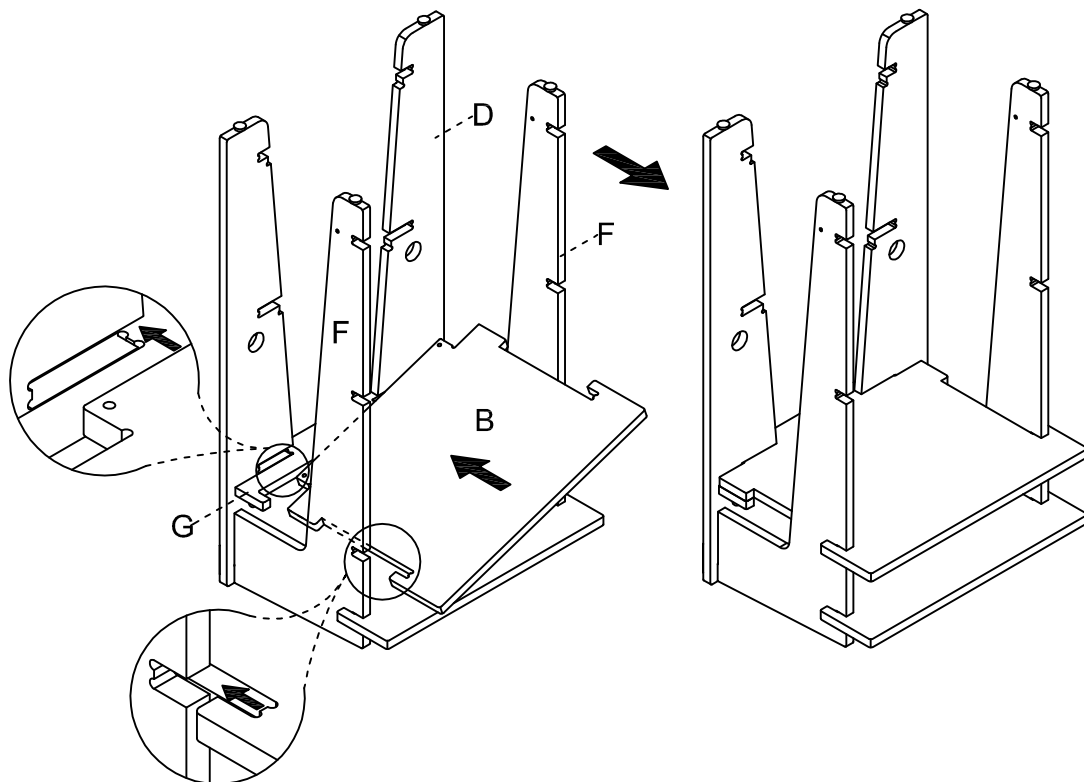

Step 5. Attach middle bar (part H) to back panel (part D).

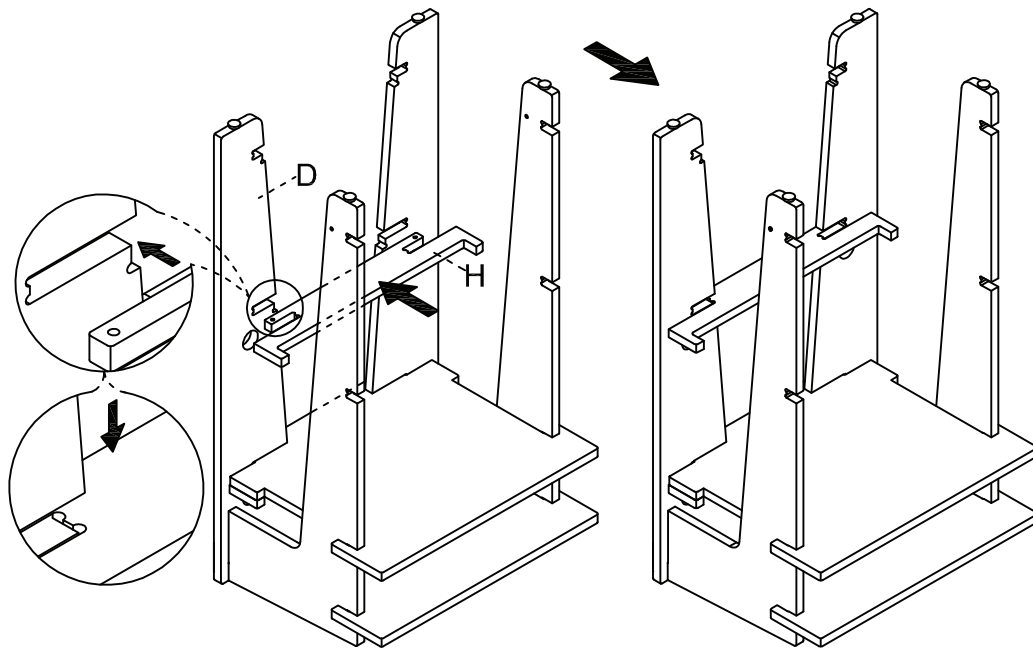

Step 6. Attach lower shelf (part C) to assembled unit (parts D, F & H).

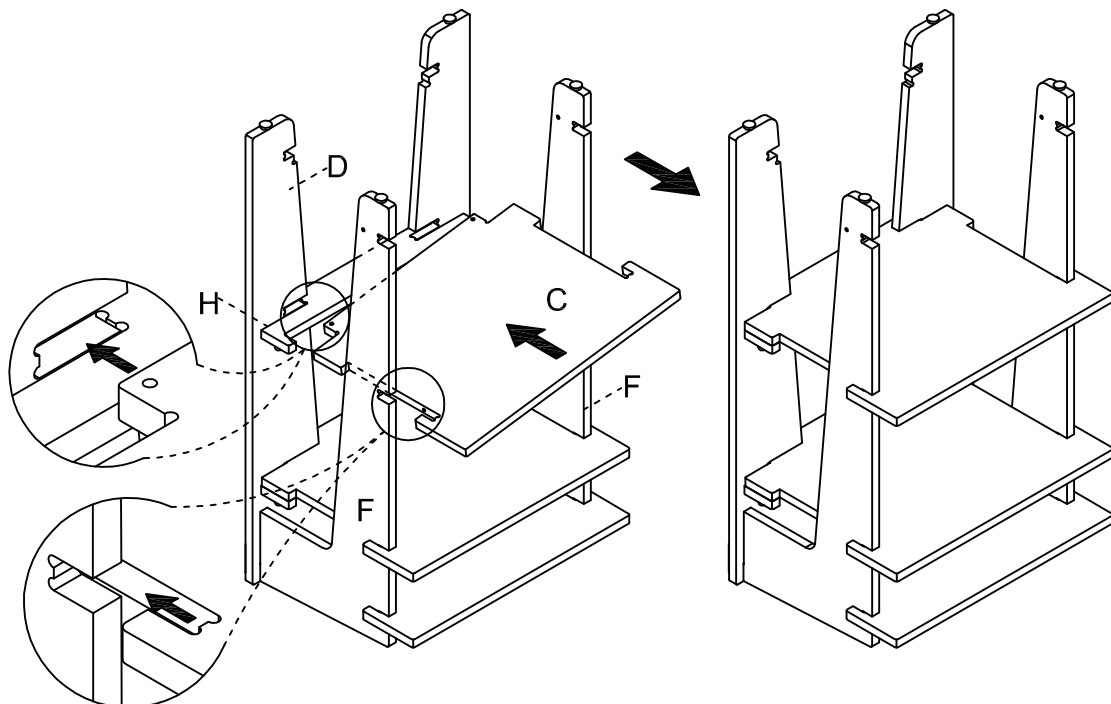

Step 7. Attach lower bar (part E) to back panel (part D).

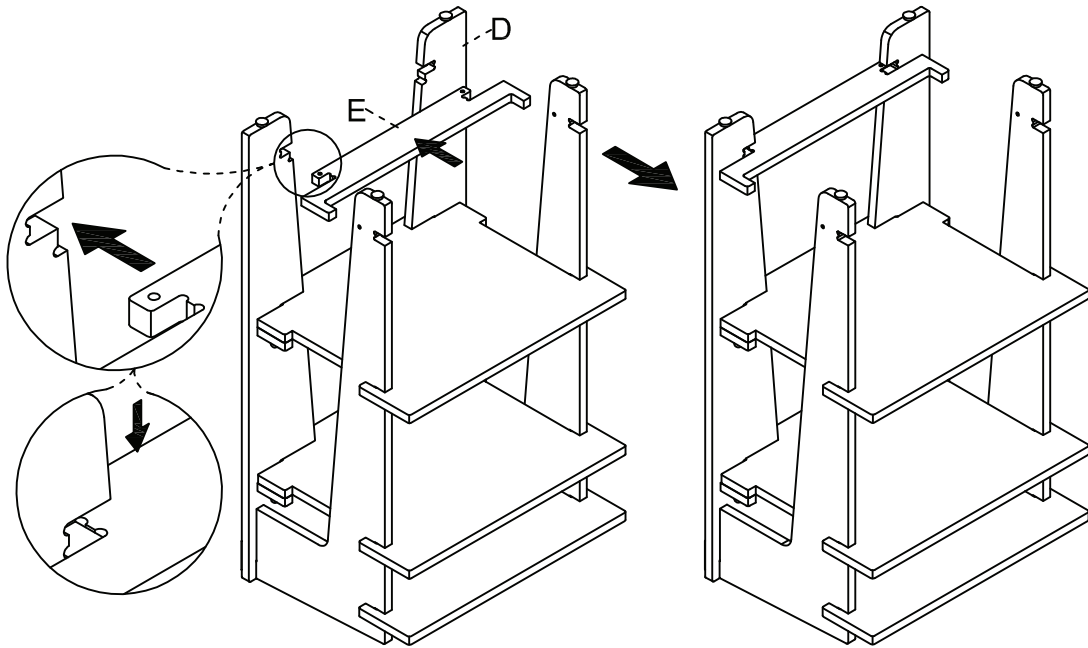

Step 8. Attach lower shelf (part C) to assembled unit (parts D, E & F).

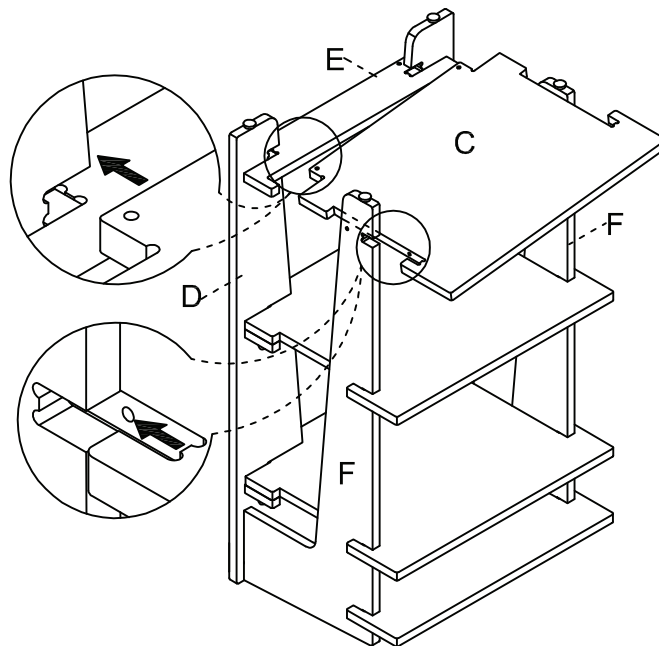

Step 9. Secure fixed shelves using plastic pins (part #1).

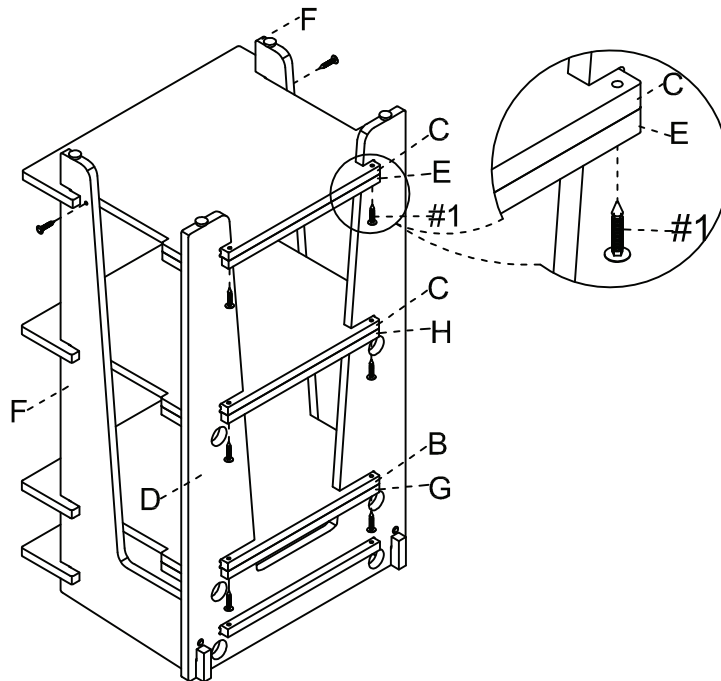

1  X 8

Step 10. Carefully turn unit upright. Attach plastic wire boxes (part I) to back panel (part D) as shown below.

