

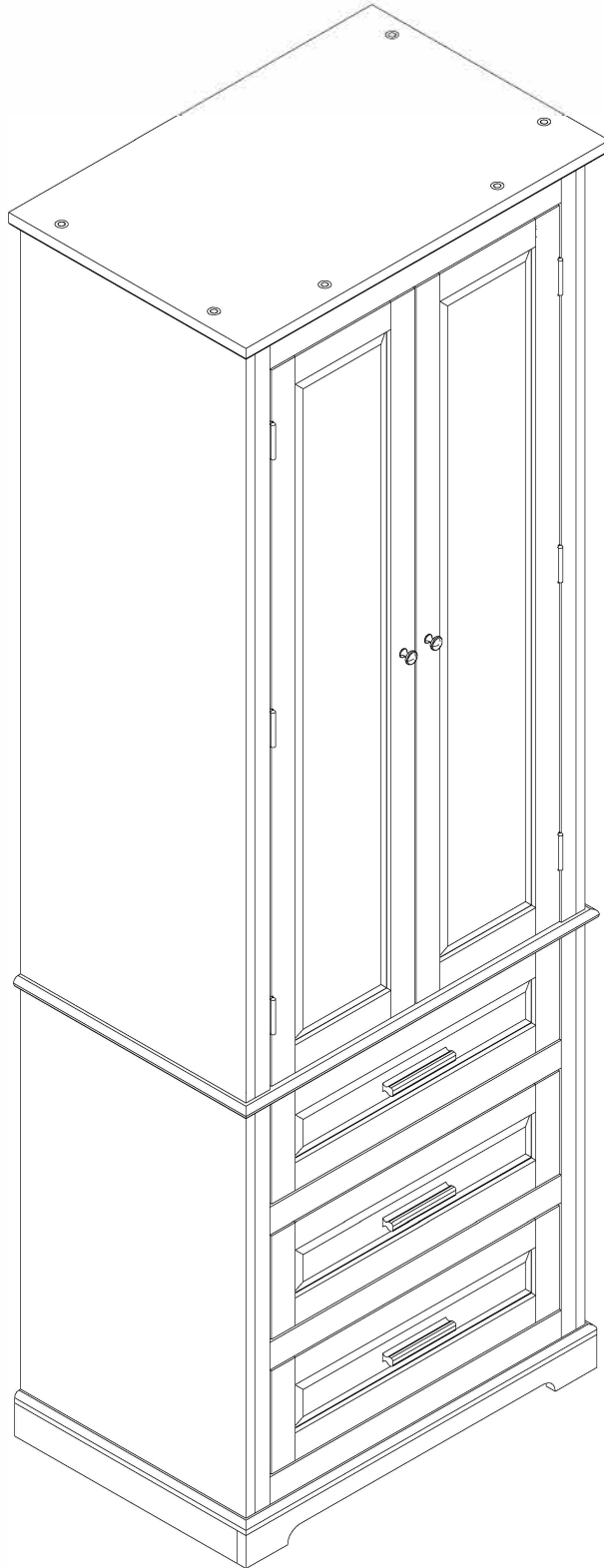

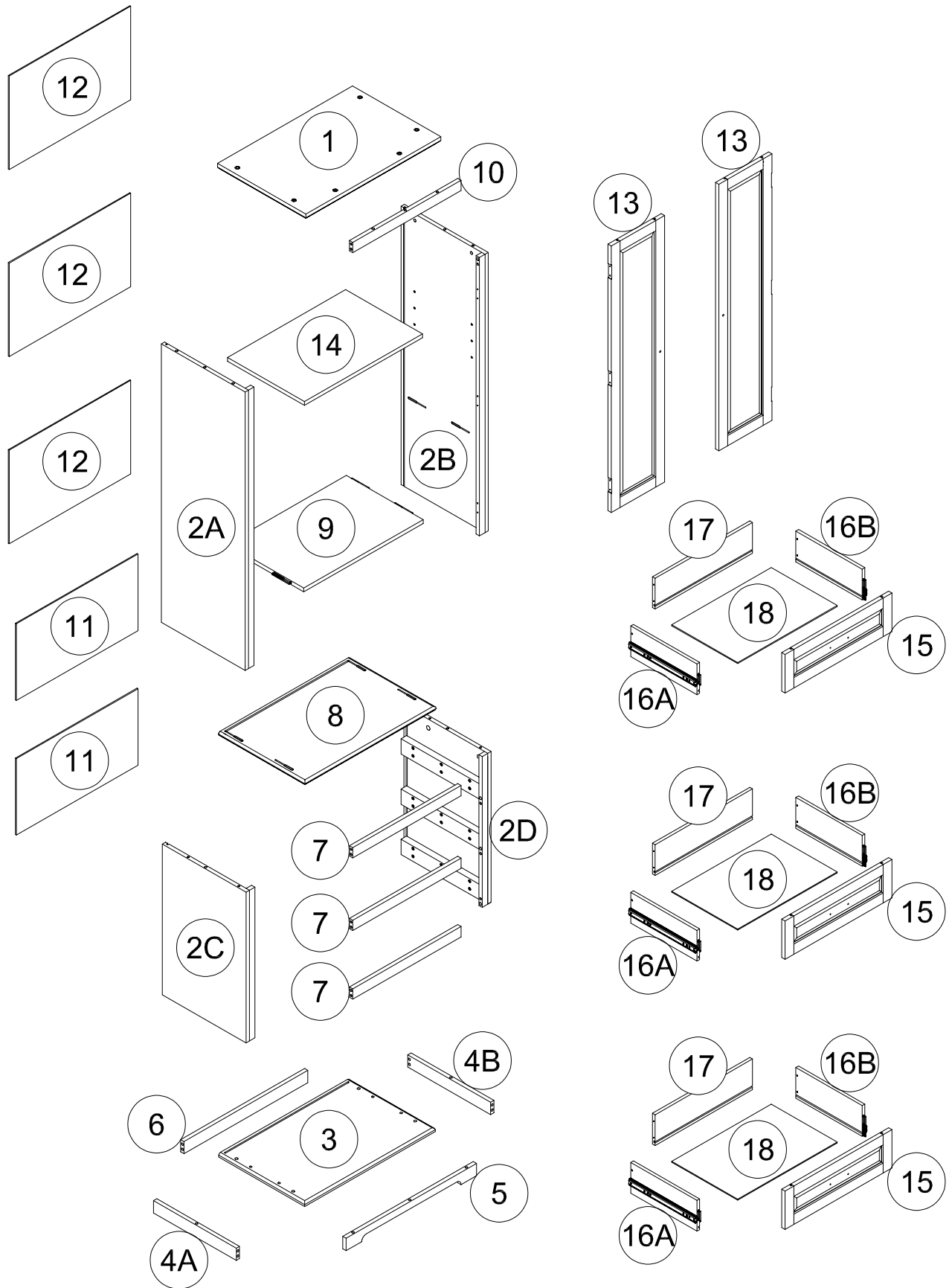

ASSEMBLY INSTRUCTIONS



ASSEMBLY INSTRUCTIONS

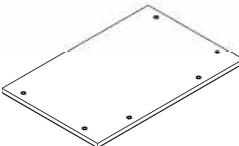
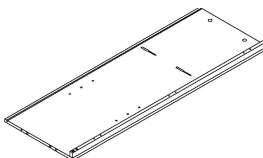
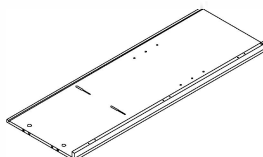
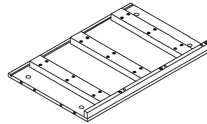
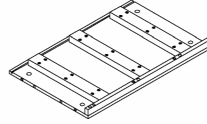
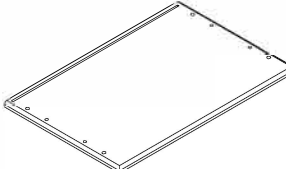
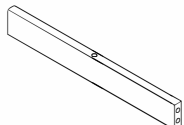
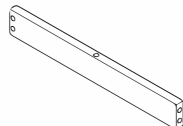
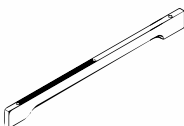
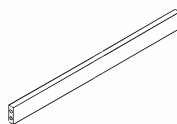
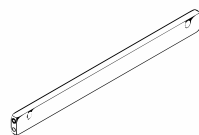
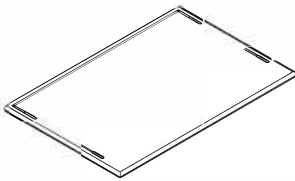

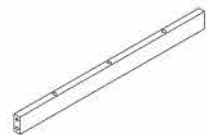
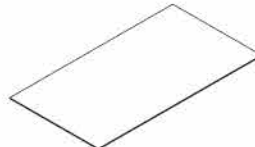
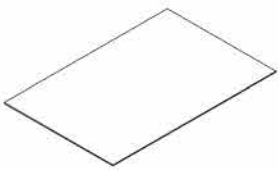
Part List

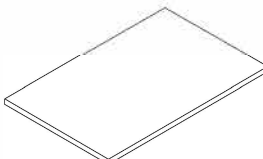
<p>1</p>  <p>Top of Cabinet - 1 pc</p>	<p>2A</p>  <p>Upper left side - 1 pc</p>	<p>2B</p>  <p>Upper right side - 1 pc</p>
<p>2C</p>  <p>Lower left side - 1 pc</p>	<p>2D</p>  <p>Lower right side - 1 pc</p>	<p>3</p>  <p>Bottom of the cabinet - 1 pc</p>
<p>4A</p>  <p>Cabinet legs - 1 pc</p>	<p>4B</p>  <p>Cabinet legs - 1 pc</p>	<p>5</p>  <p>Cabinet legs - 1 pc</p>
<p>6</p>  <p>Cabinet legs - 1 pc</p>	<p>7</p>  <p>Horizontal bar - 3 pcs</p>	<p>8</p>  <p>Middle of the cabinet - 1 pc</p>
<p>9</p>  <p>Fixed shelf - 1 pc</p>	<p>10</p>  <p>Horizontal bar - 1 pc</p>	<p>11</p>  <p>Lower back panels - 2 pcs</p>
<p>12</p>  <p>Upper back panels - 3 pcs</p>	<p>13</p>  <p>Cabinet door - 2 pcs</p>	<p>14</p>  <p>Adjustable shelf - 1 pc</p>

Part List

15

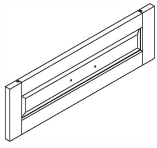

Drawer - Front side - 3 pcs

16A

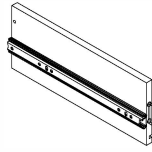

Drawer - Side rails - 3 pcs

16B

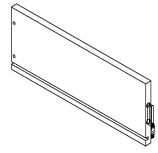

Drawer - Side rails - 3 pcs

17

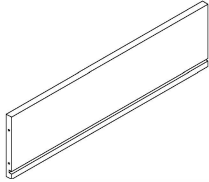





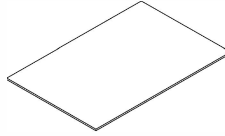



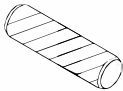

Drawer - Back Panels - 3 pcs

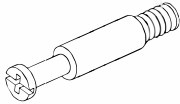
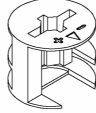
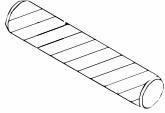
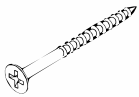
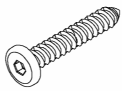
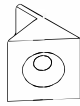
18

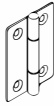
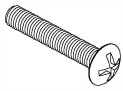

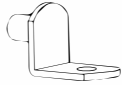
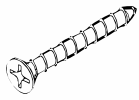
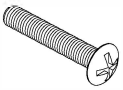
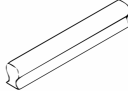
Drawer - Bottom Panels - 3 pcs

Hardware List

<p>A</p>  <p>Ø8 x 30 mm Wood dowel 25 pcs</p>	<p>B</p>  <p>Steel Bracket 10 pcs</p>	<p>C</p>  <p>M4 x 15 mm Wood Screws 24 pcs</p>
<p>D</p>  <p>Cam Bolt 20 pcs</p>	<p>E</p>  <p>Cam Lock 10mm 20 pcs</p>	<p>F</p>  <p>Ø8 x 60 mm Wood dowel 4 pcs</p>
<p>G</p>  <p>M4 x 50 mm Wood Screws 2 pcs</p>	<p>H</p>  <p>1/4" x 50 mm Wood Screws 4 pcs</p>	<p>I</p>  <p>Plastic Wedges 28 pcs</p>
<p>J</p>  <p>M4 x 20 mm Wood Screws 52 pcs</p>	<p>K</p>  <p>Hinge 6 pcs</p>	<p>L</p>  <p>M4 x 20 mm Truss Head Wood Screws 2 pcs</p>
<p>M</p>  <p>Cabinet Door Handle 2 pcs</p>	<p>N</p>  <p>Shelf Pin 9mm 4 pcs</p>	<p>O</p>  <p>M4 x 30 mm Wood Screws 12 pcs</p>
<p>P</p>  <p>M4 x 12 mm Truss Head Wood Screws 6 pcs</p>	<p>Q</p>  <p>Drawer Handles 3 pcs</p>	<p>R</p>  <p>Allen Key 1 pc</p>
<p>S</p>  <p>1 2 3 4 5 Antifall 2 sets</p>	<p>T</p>  <p>Drawer slide 6 pcs</p>	<p>U</p>  <p>M3.5 x 15 mm Wood Screws 24 pcs</p>

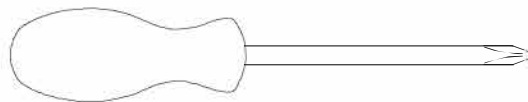

Assembly Tools Required (Not Included)

Step 1:

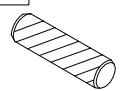
A

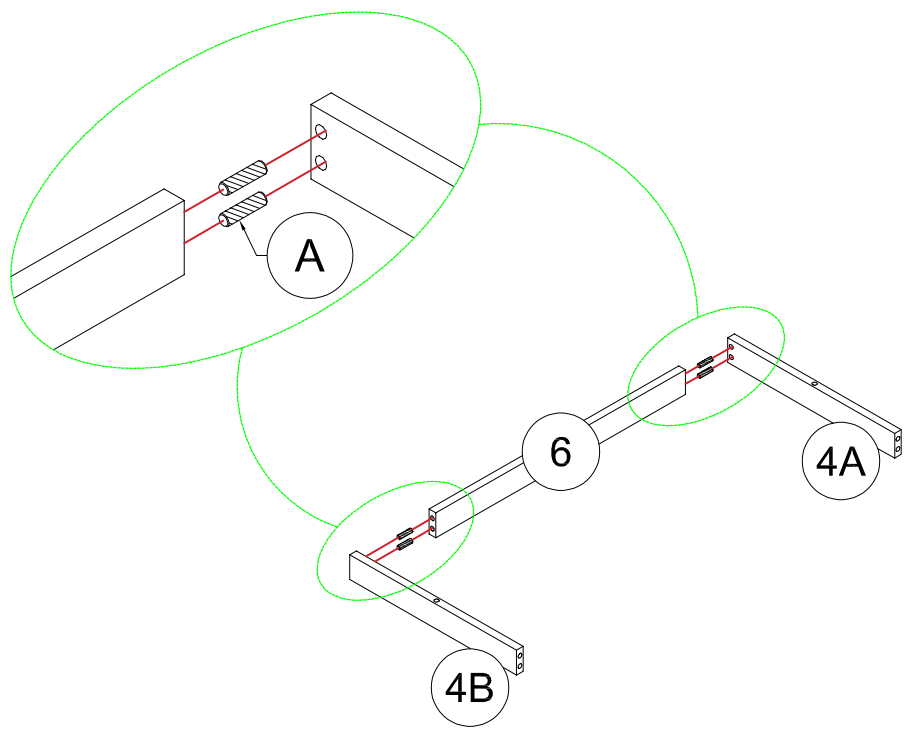
4pcs



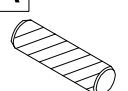

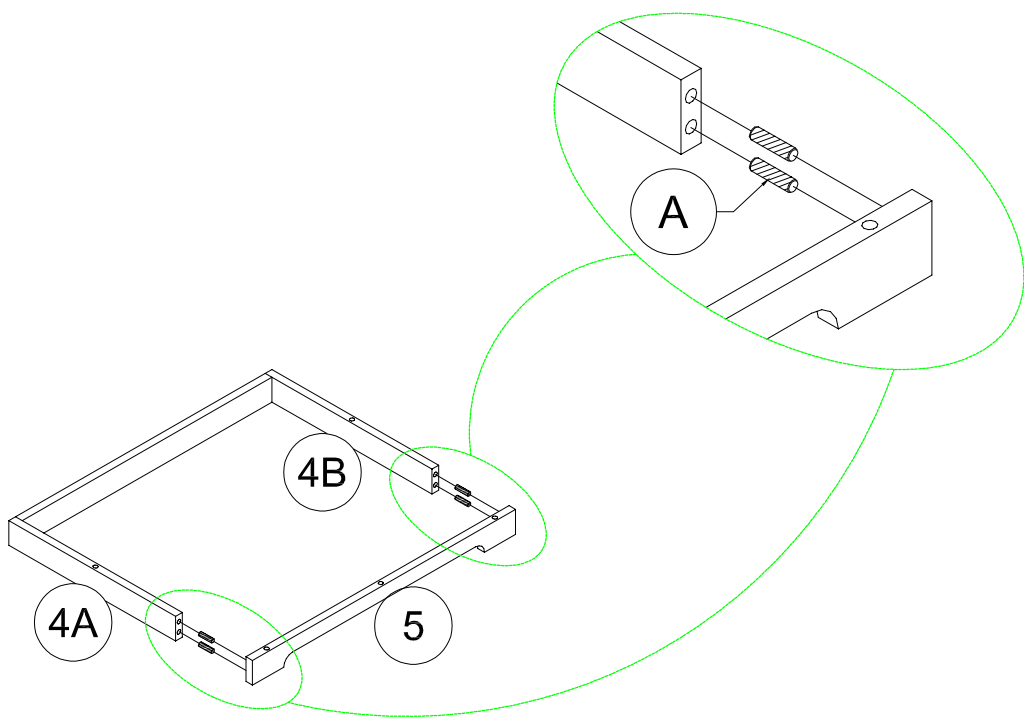
Step 2:

A

4pcs

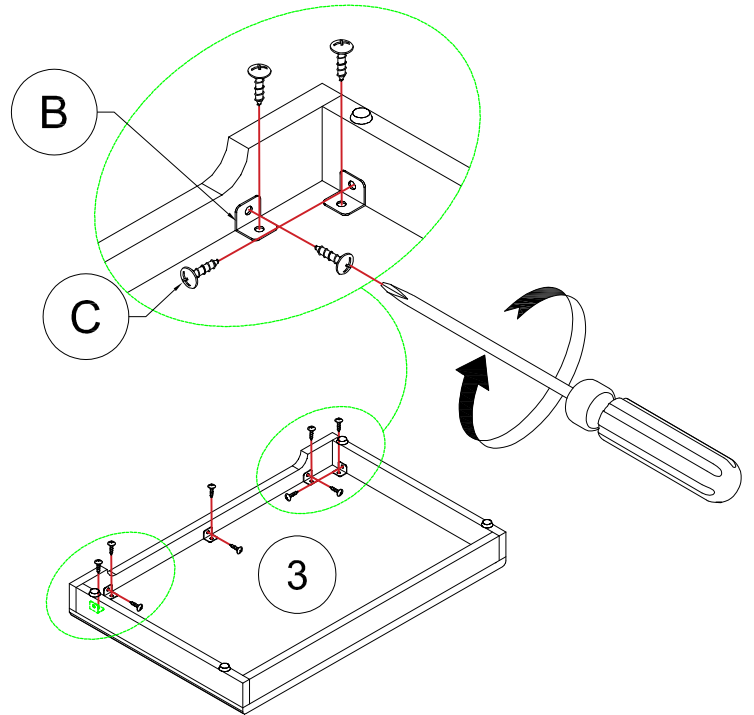
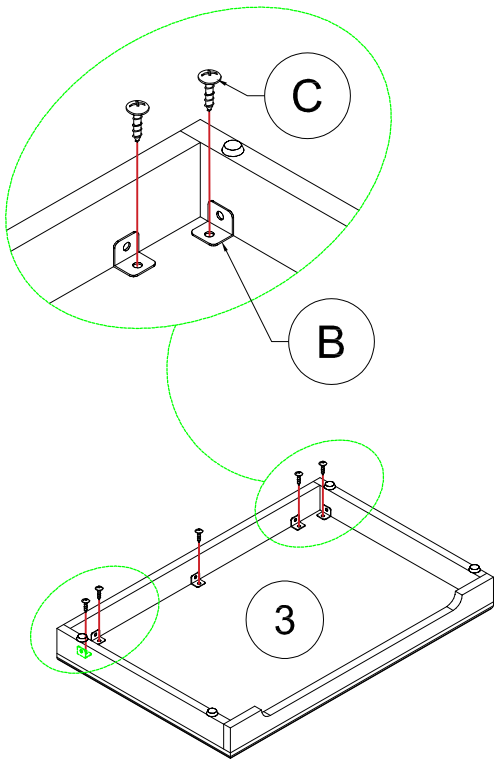

Step 3:

B	C
	
10pcs	20pcs



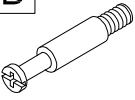

Step 4:

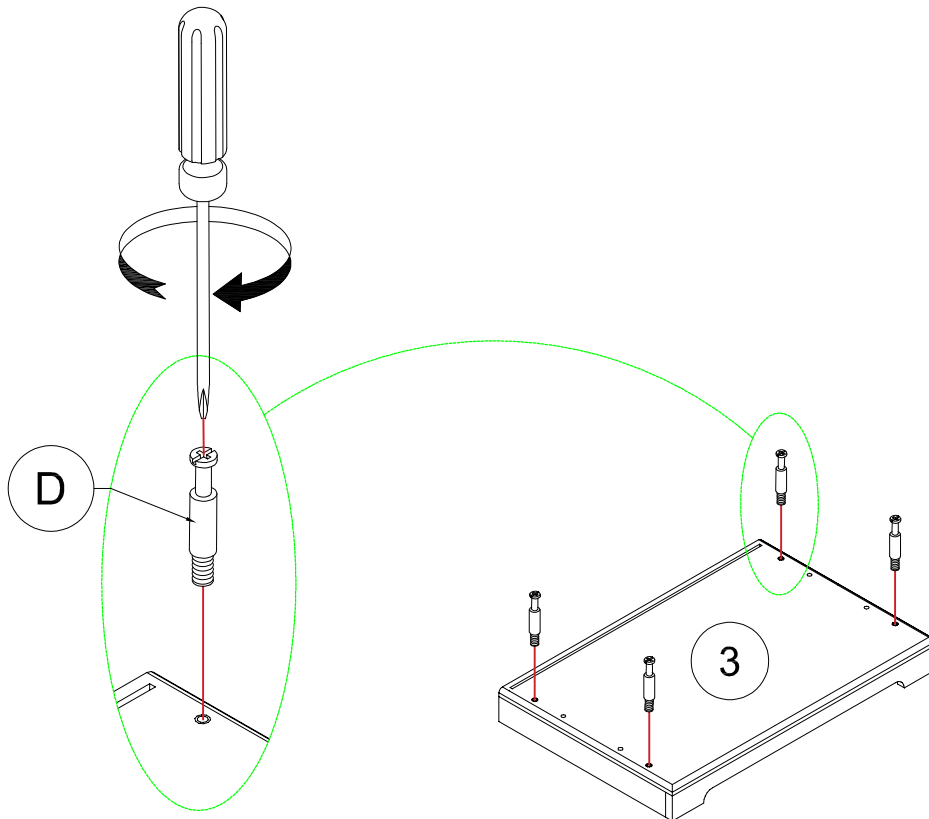
D

4pcs

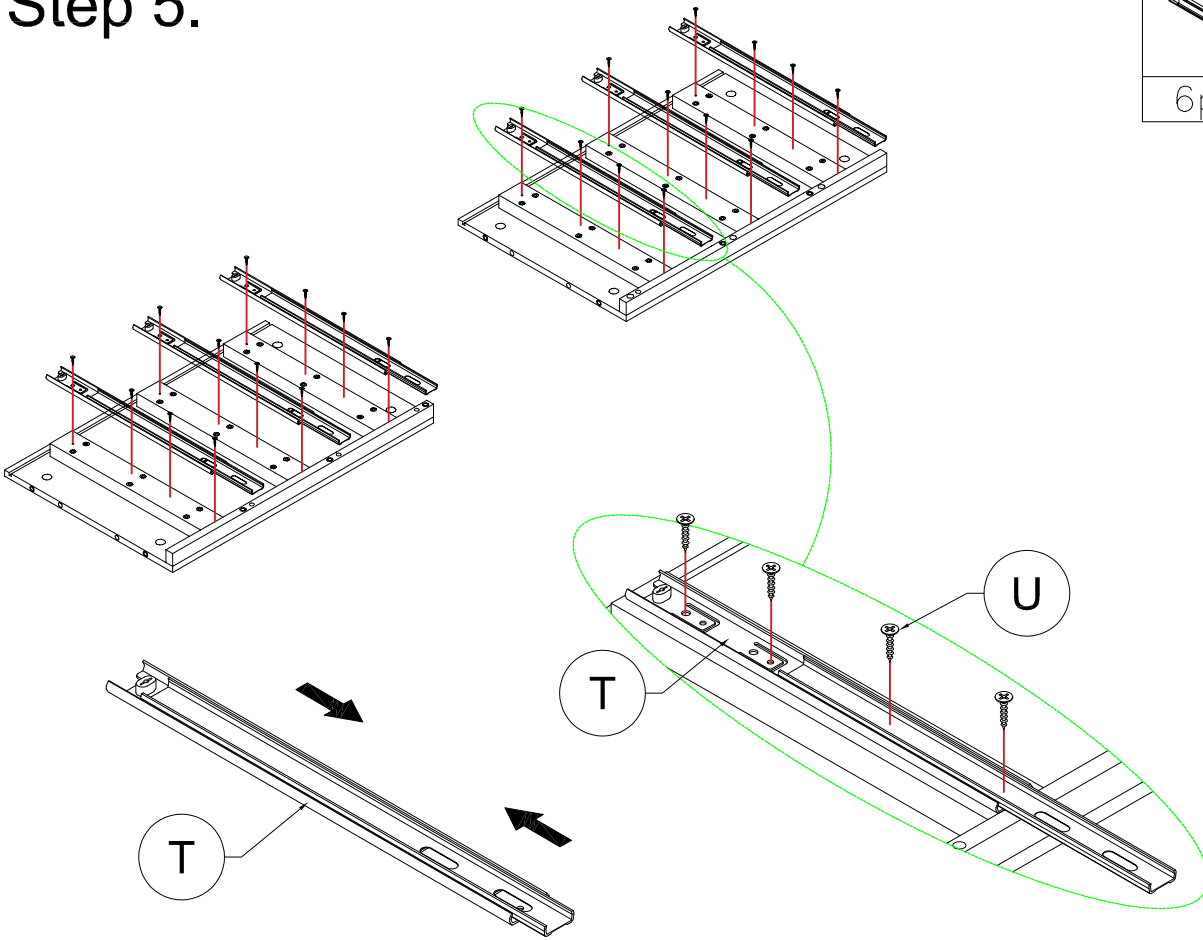

Step 5:

T	U
	
6pcs	24pcs



Move the slide rail to screw in

Step 6:

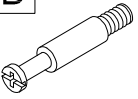
D

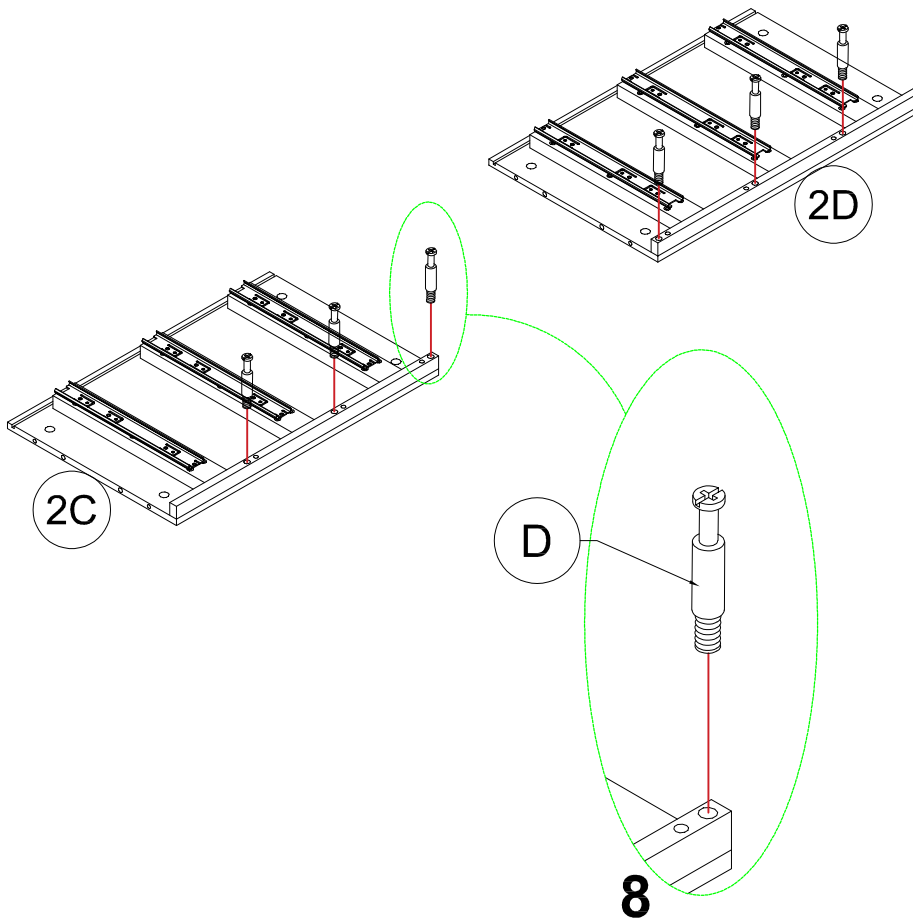
6pcs

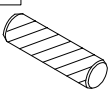

Step 7:

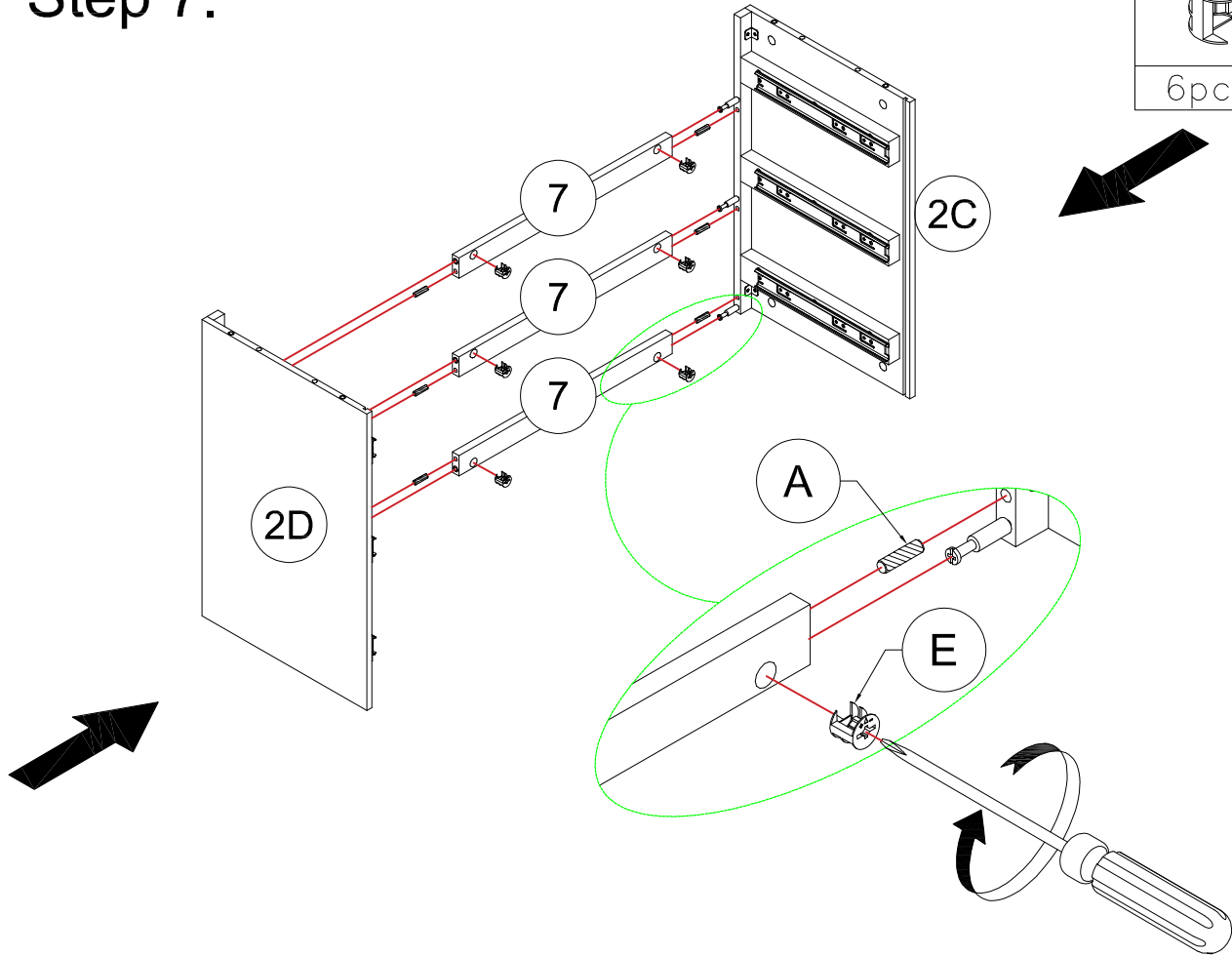
E	A
	
6pcs	6pcs

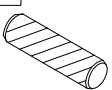

Step 8:

E	A
	
4pcs	4pcs

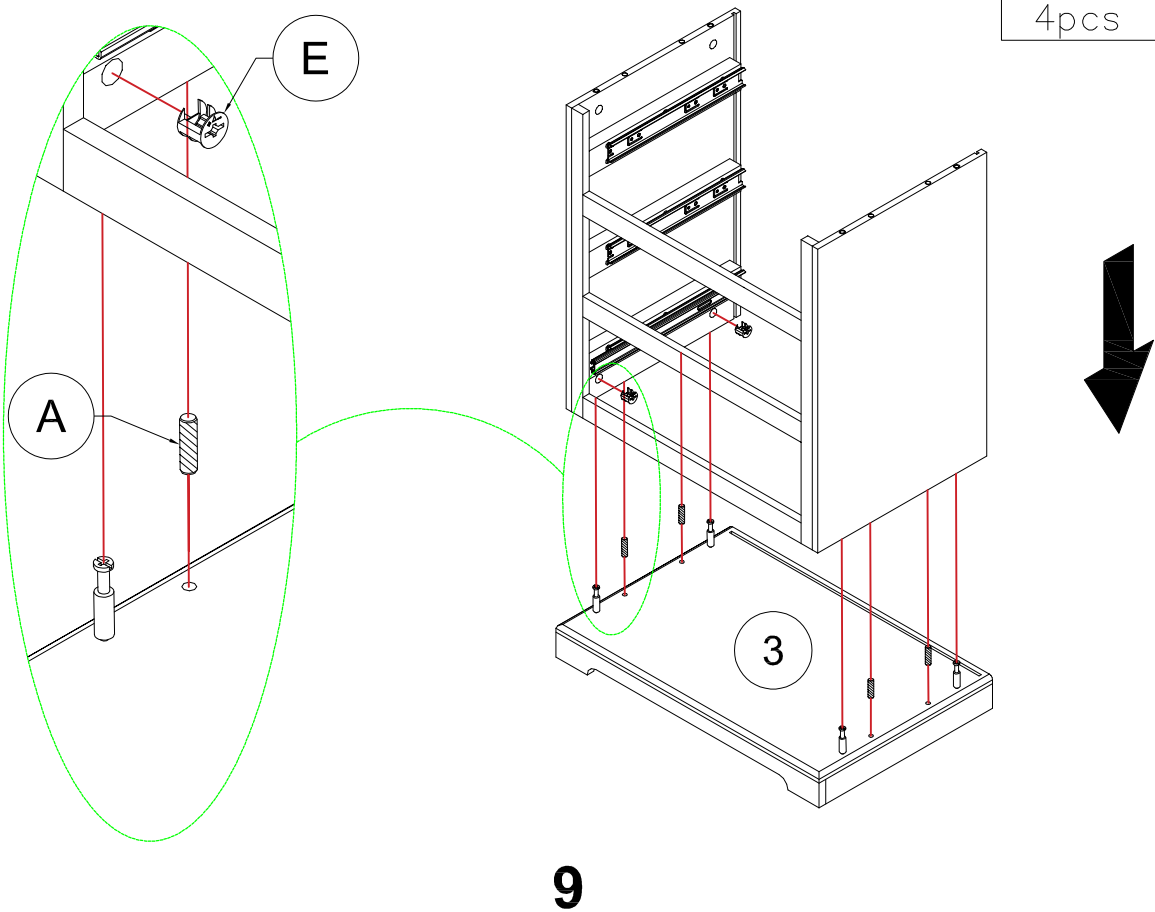

Step 9:

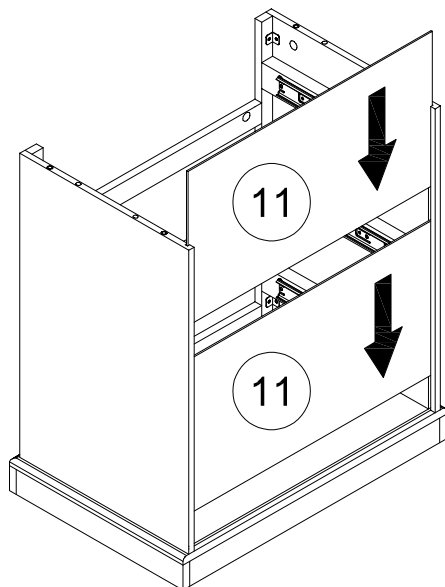

Step 10:

D

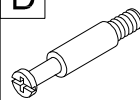

4pcs

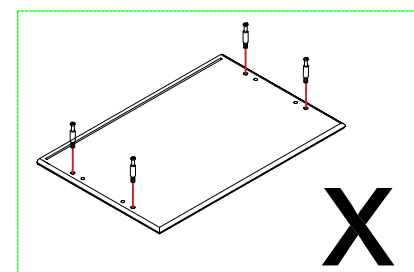
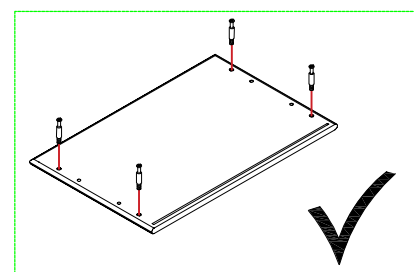
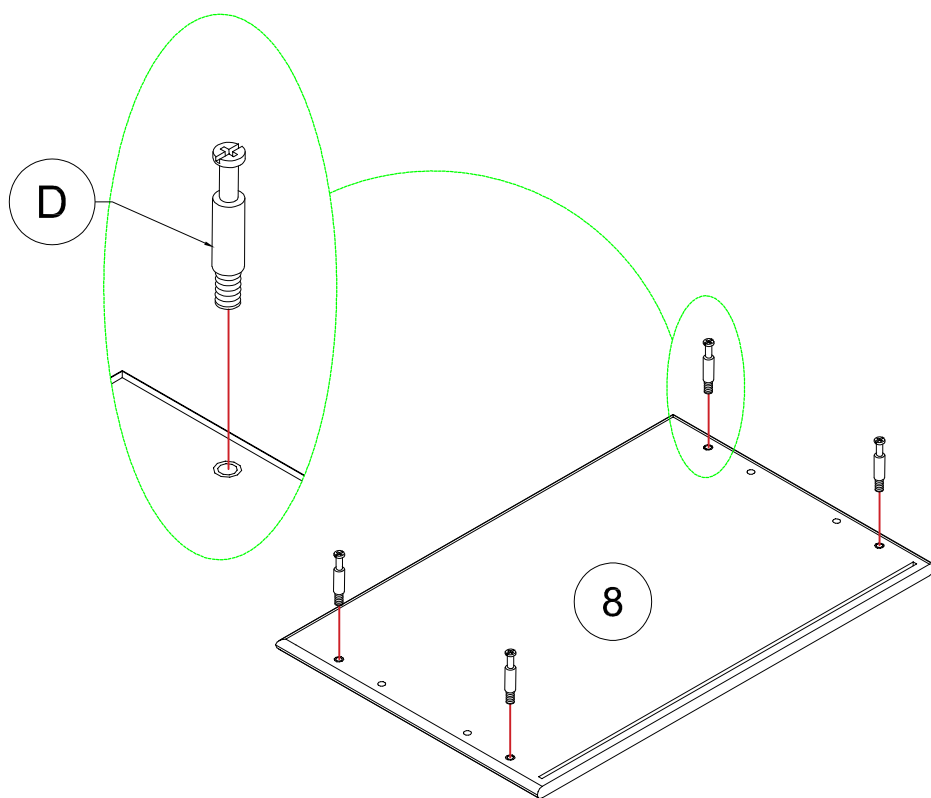

10

Step 11:

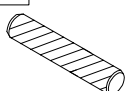
E		F	
4pcs		4pcs	

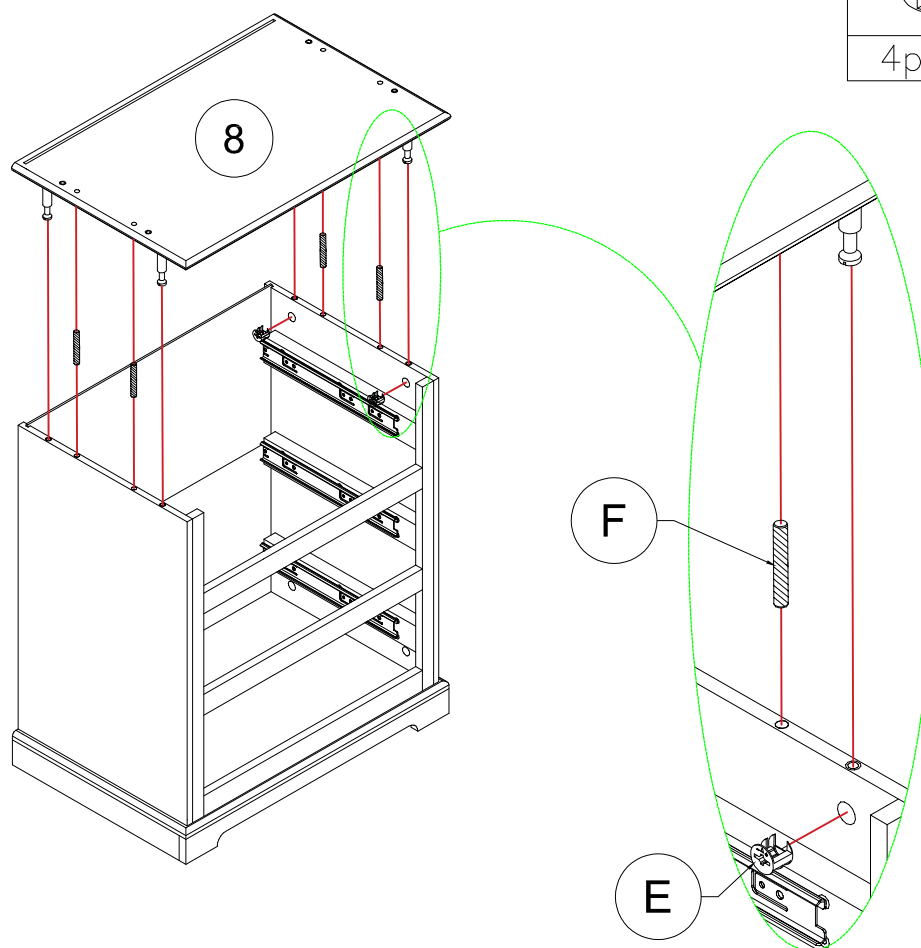

Step 12:

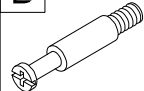
D	
4pcs	

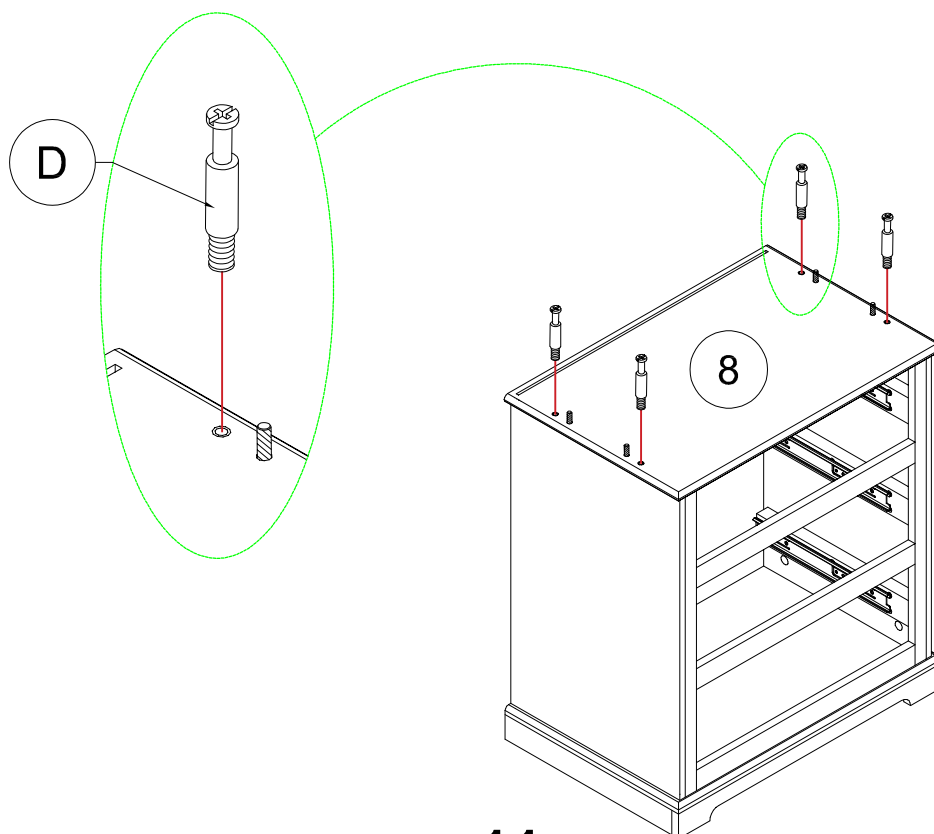

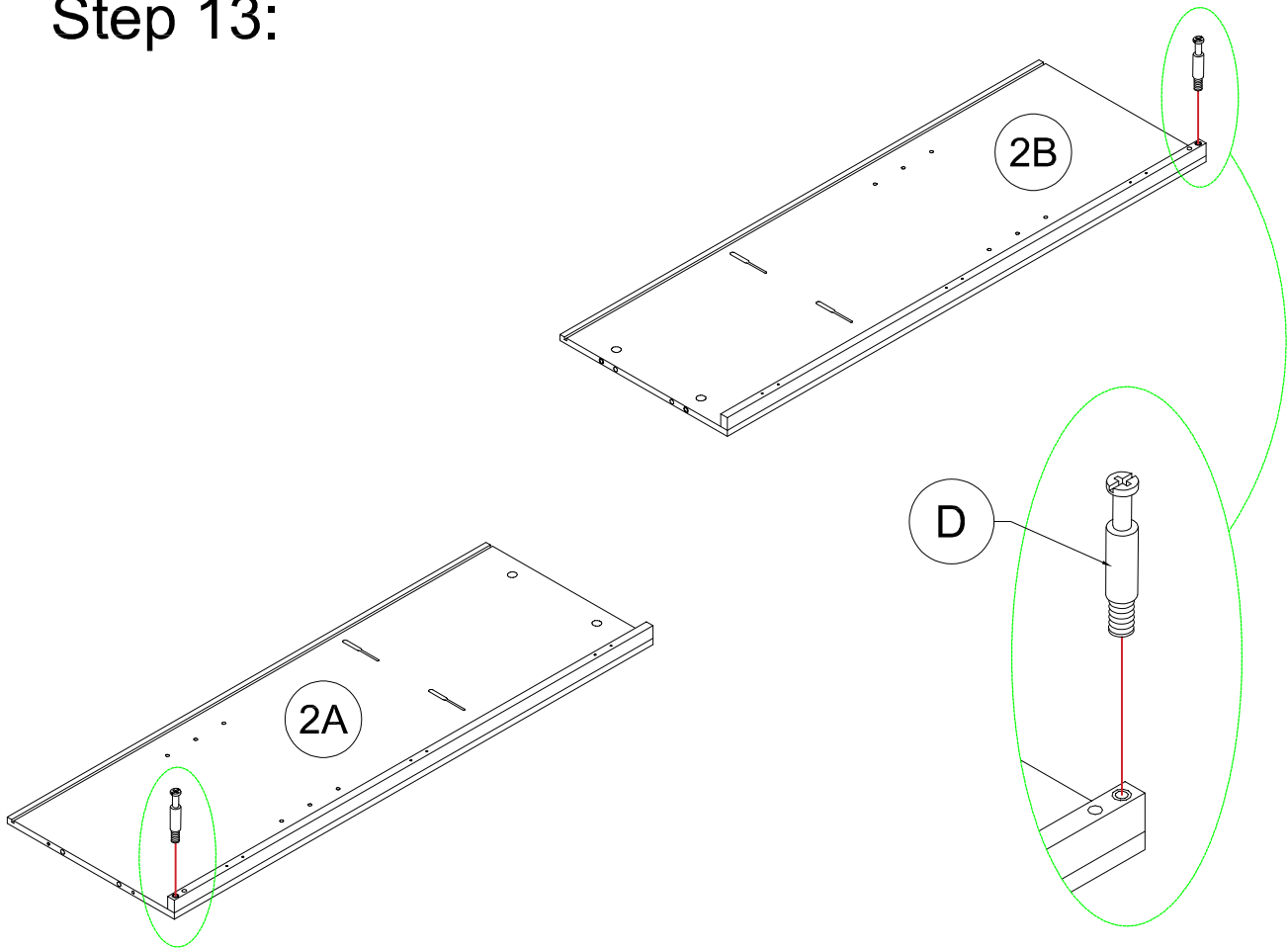

Step 13:

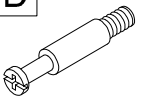

D	
2pcs	

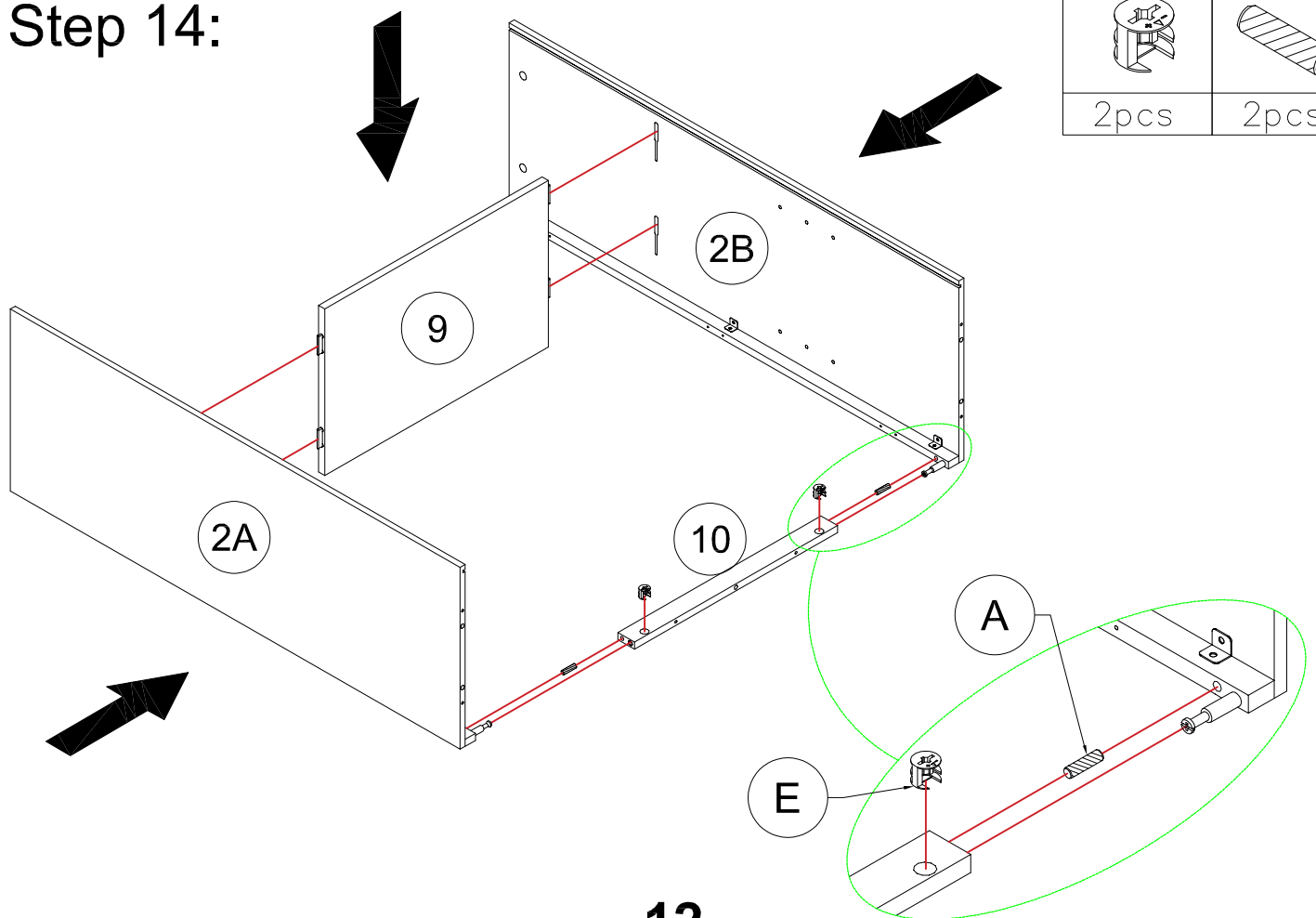
Step 14:

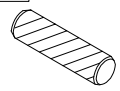

E		A	
2pcs		2pcs	

Step 15:

E



4pcs

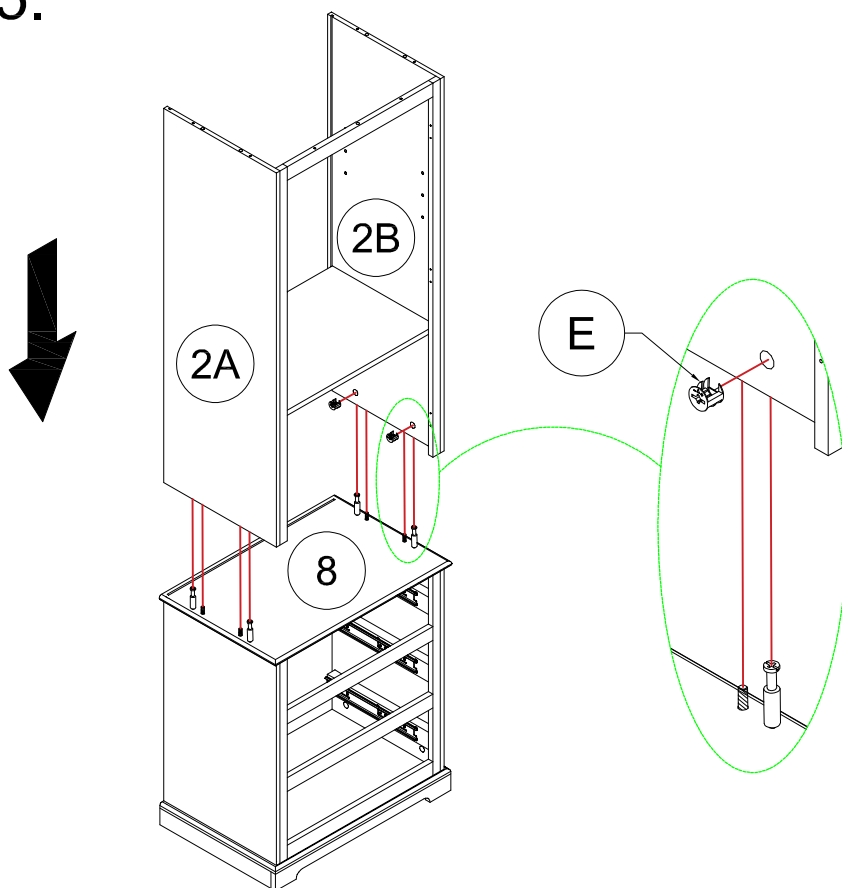

Step 16:

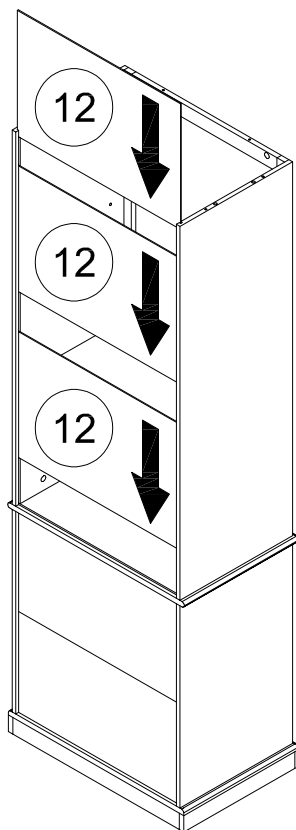

Step 17:

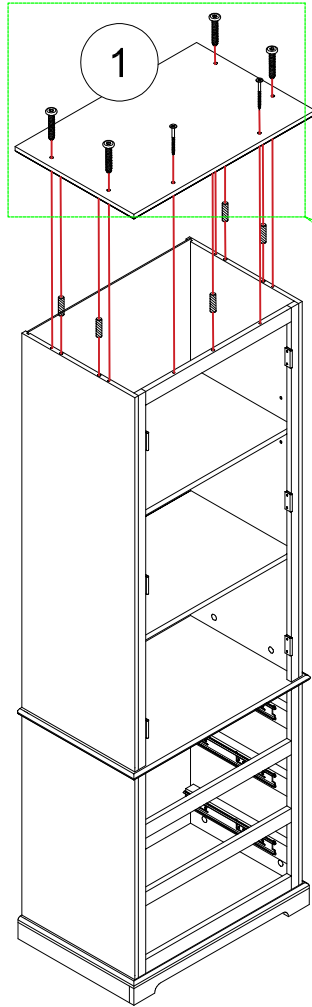

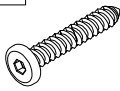
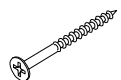
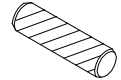

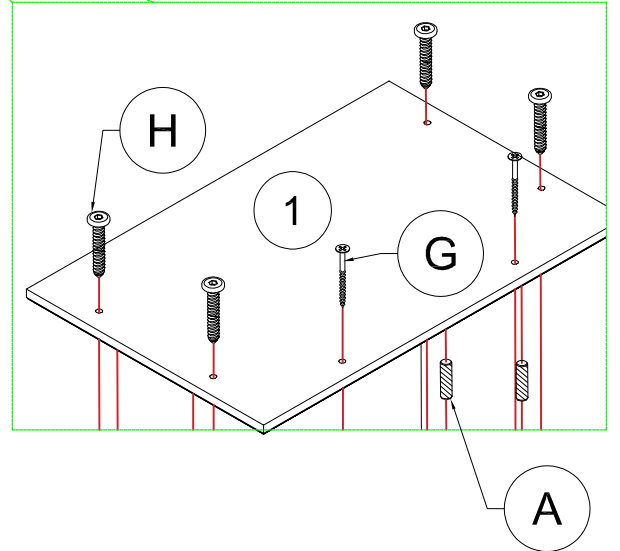
H 	G 	A 
4pcs	2pcs	5pcs

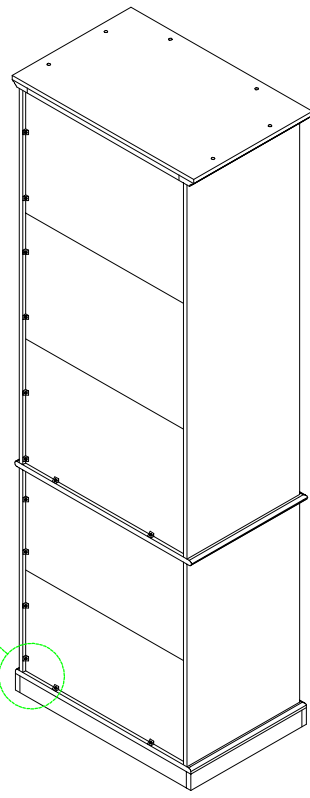
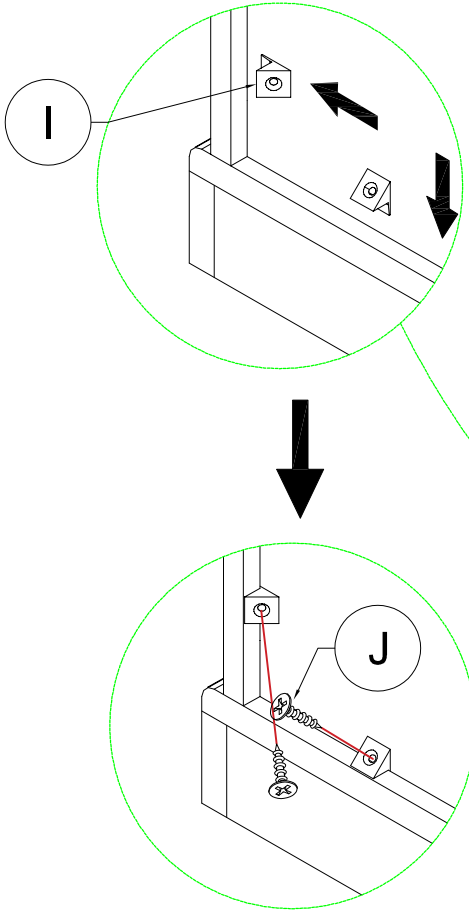
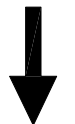

Step 18:



J 	I 
28pcs	28pcs

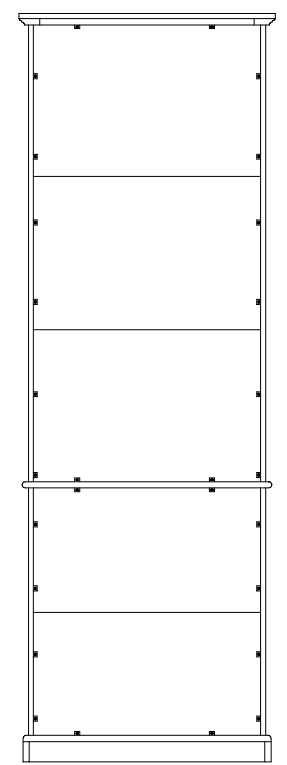

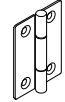

Step 19:

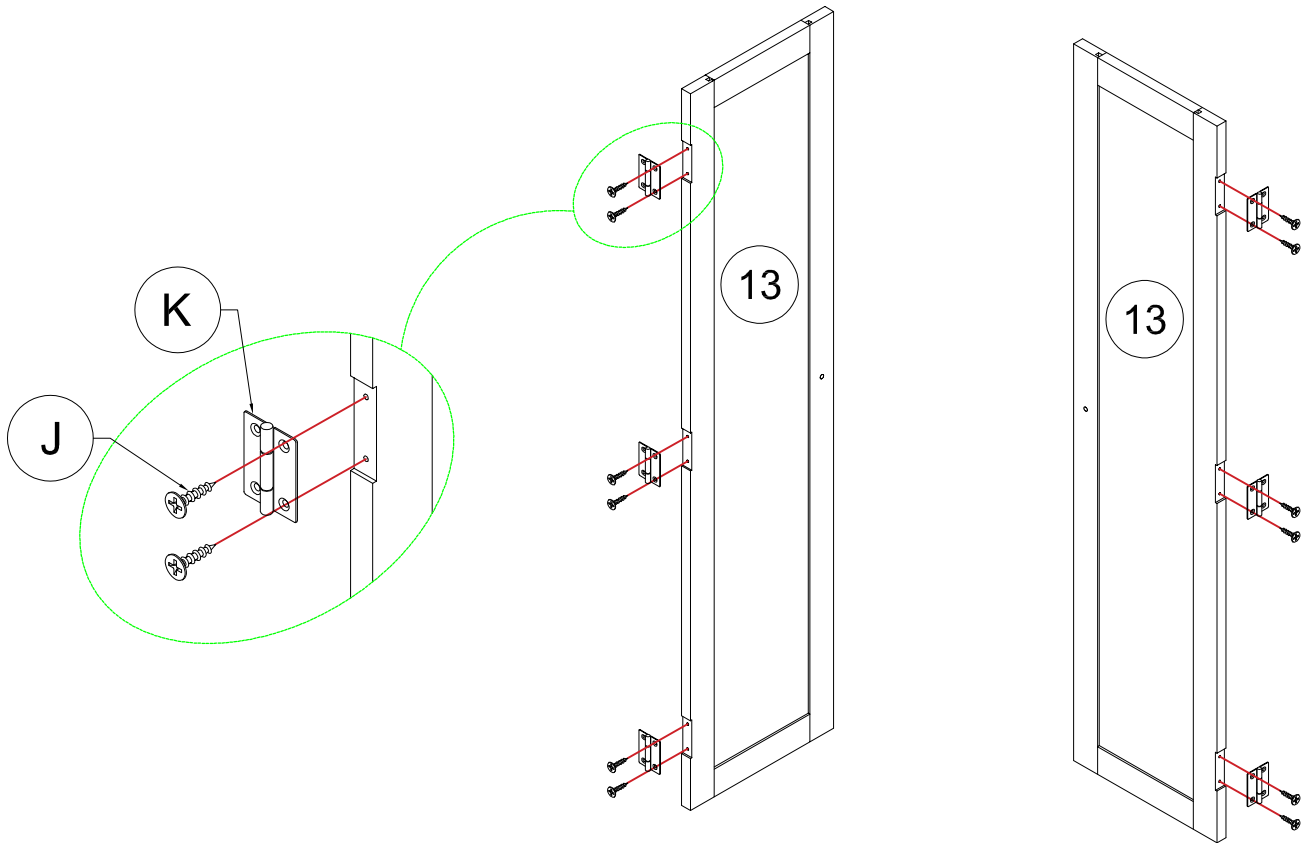
J		K	
12pcs		6pcs	



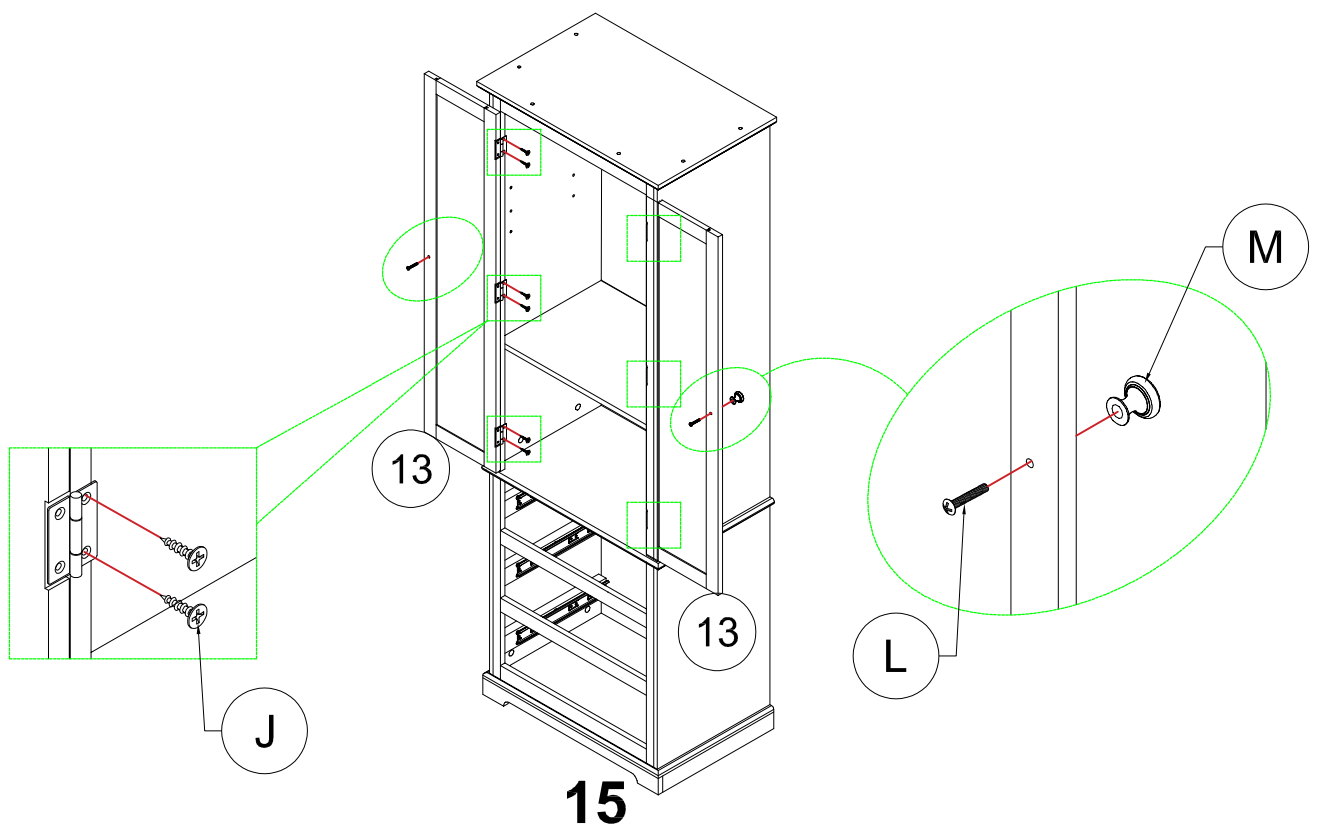

Step 20:

M		L		J	
2pcs		2pcs		12pcs	



Step 21:

N	C
	
4pcs	4pcs

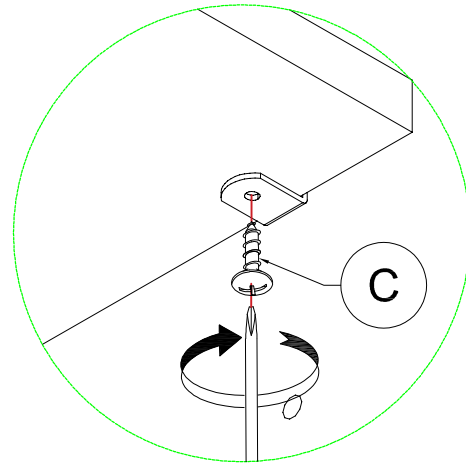
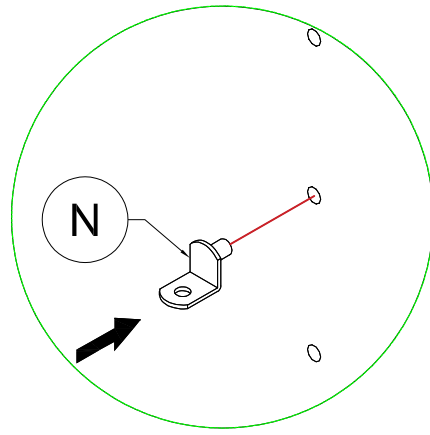
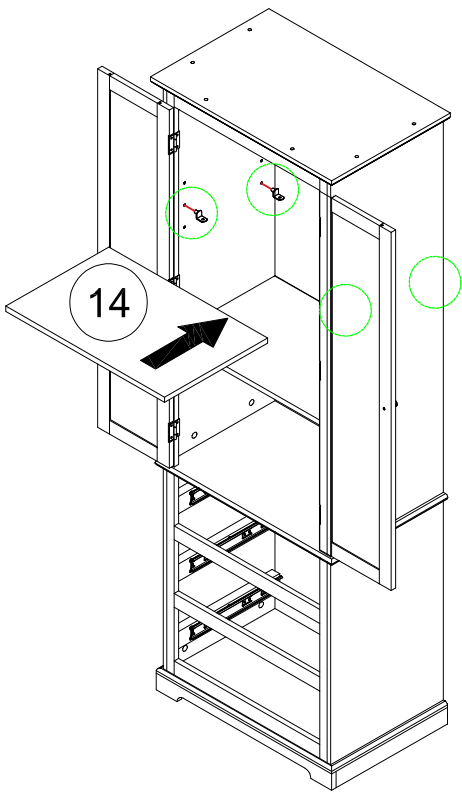

Step 22:

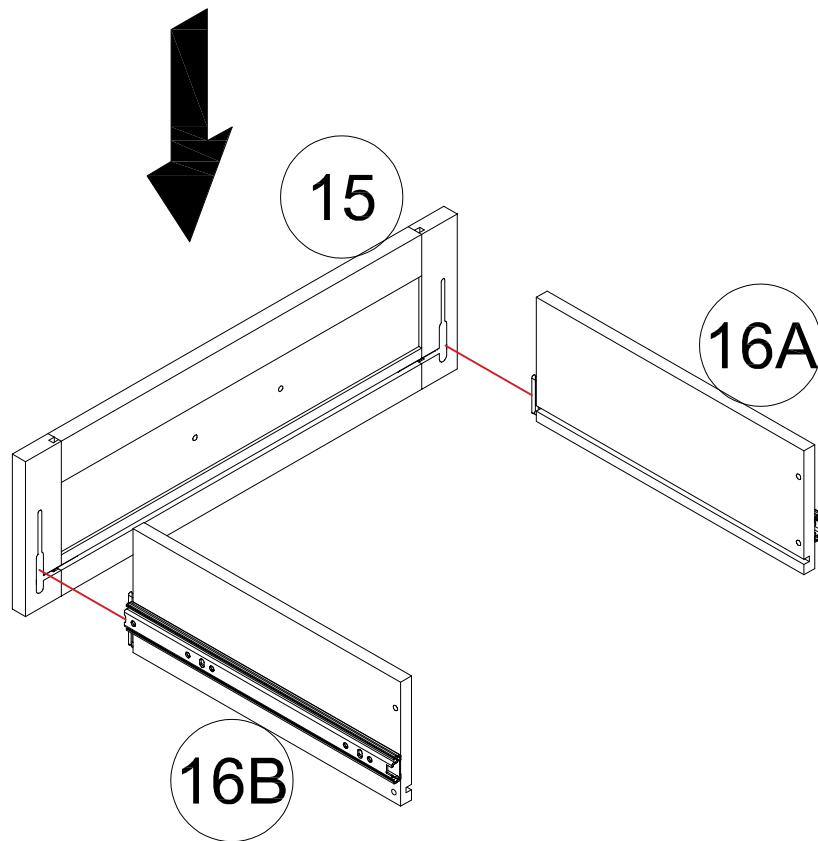

X3

16

Step 23:

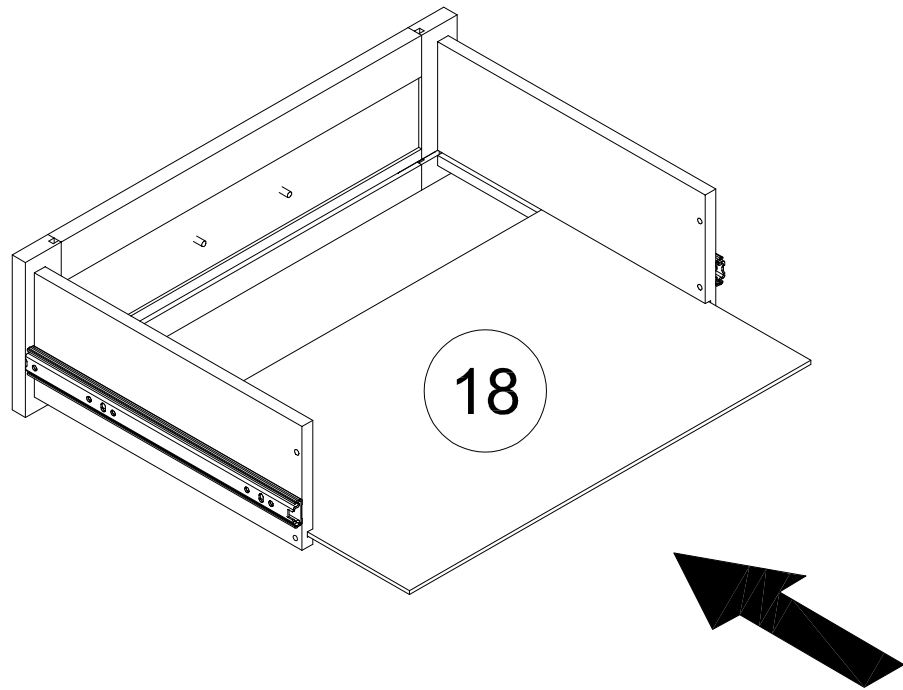

X3

Step 24:

Q	P	O
3pcs	6pcs	12pcs

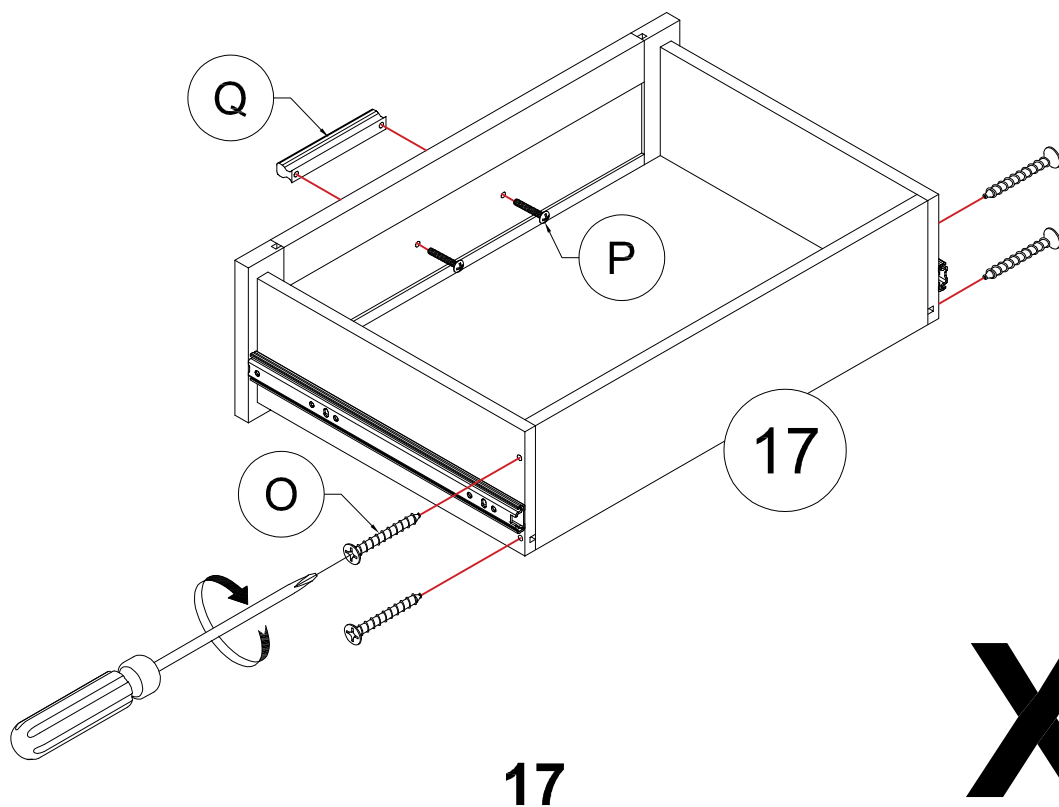

17

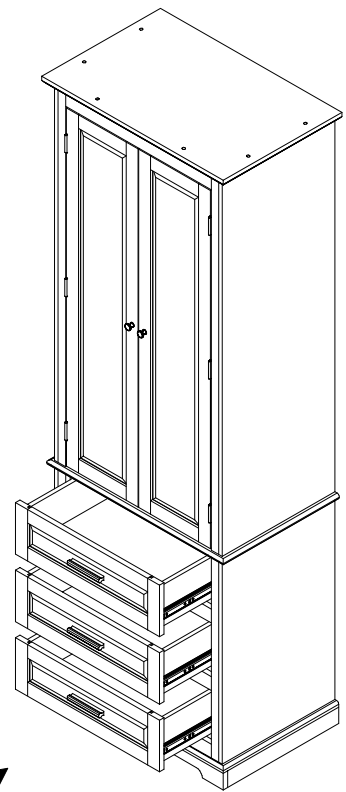
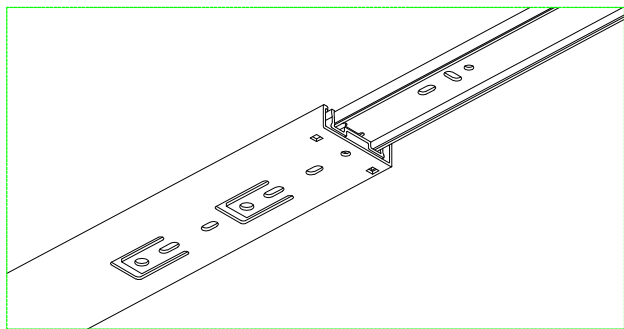
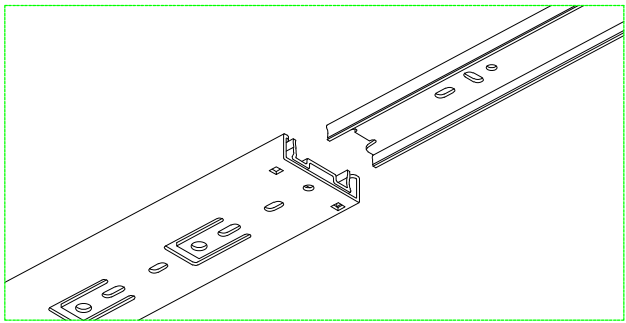

X3

Step 25:



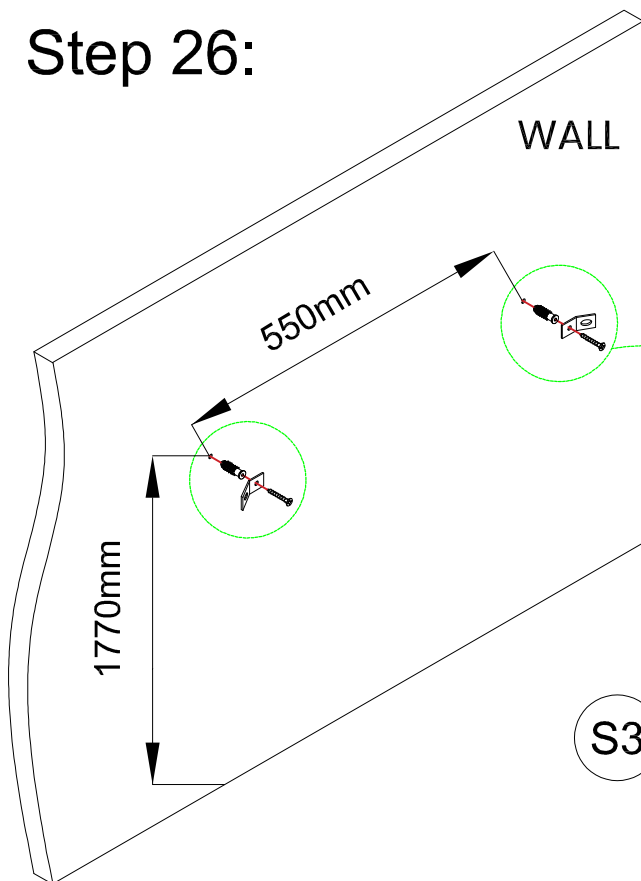

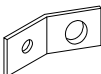
Step 26:

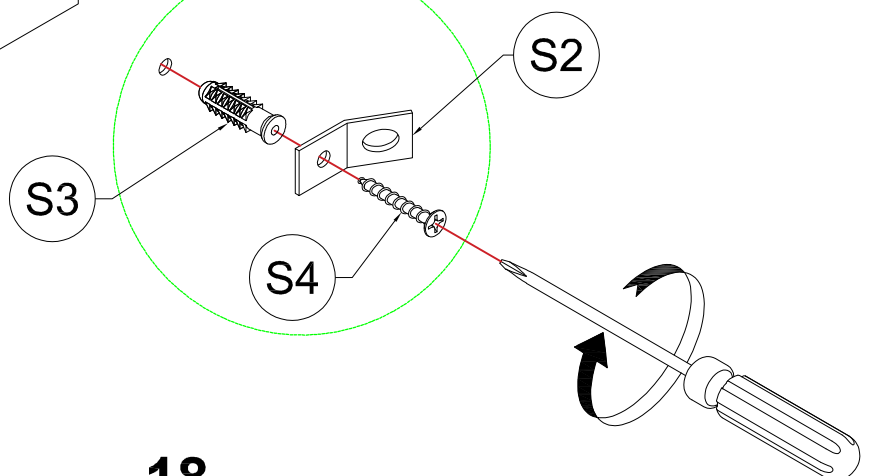

S-2	S-3	S-4
		
2pcs	2pcs	2pcs

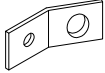

Step 27:

S-2	S-5
	
2pcs	2pcs

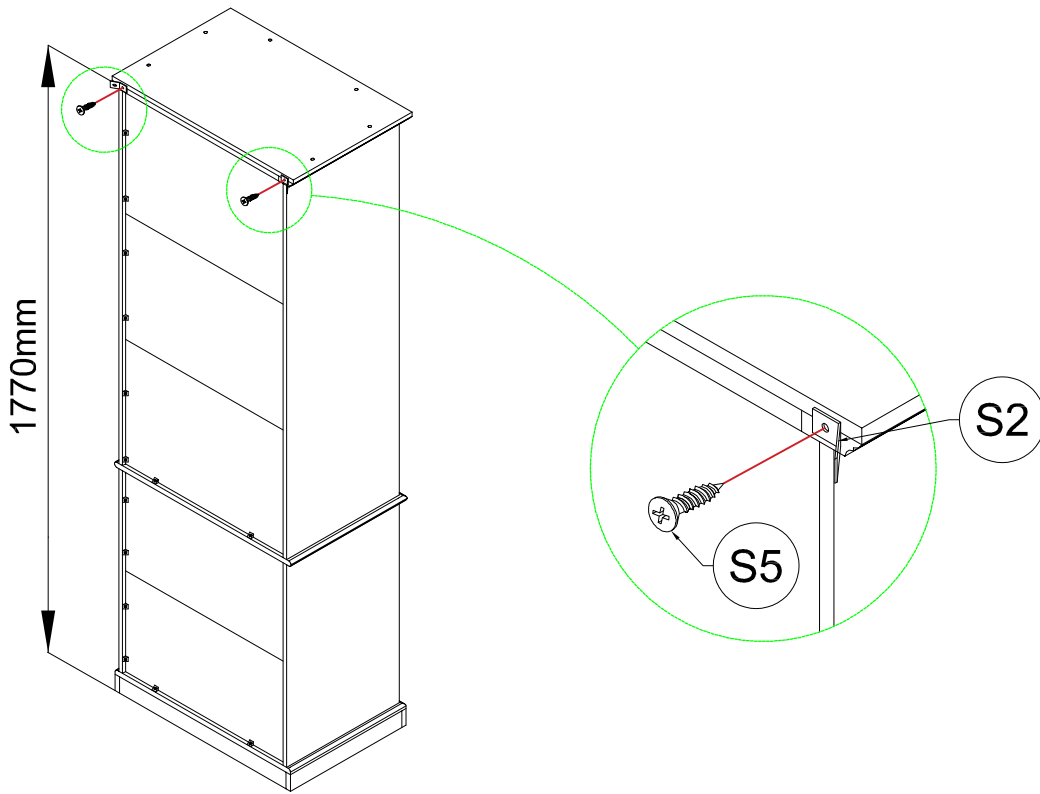

Step 28:

S-1

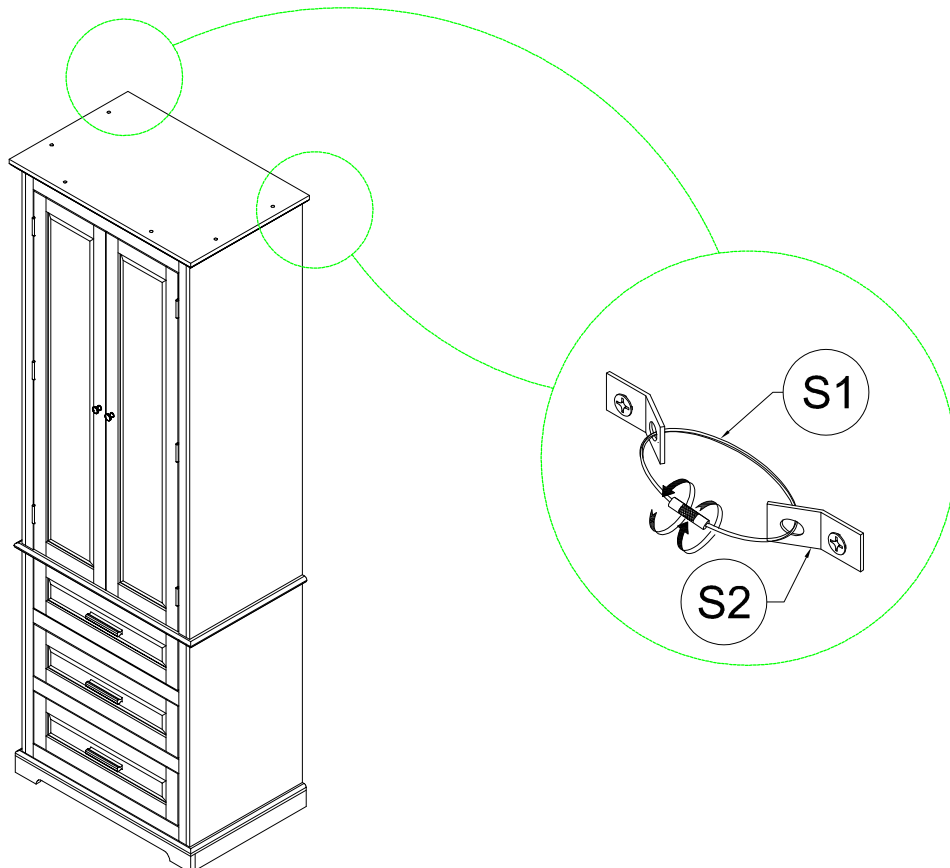
2pcs



FINISH

