

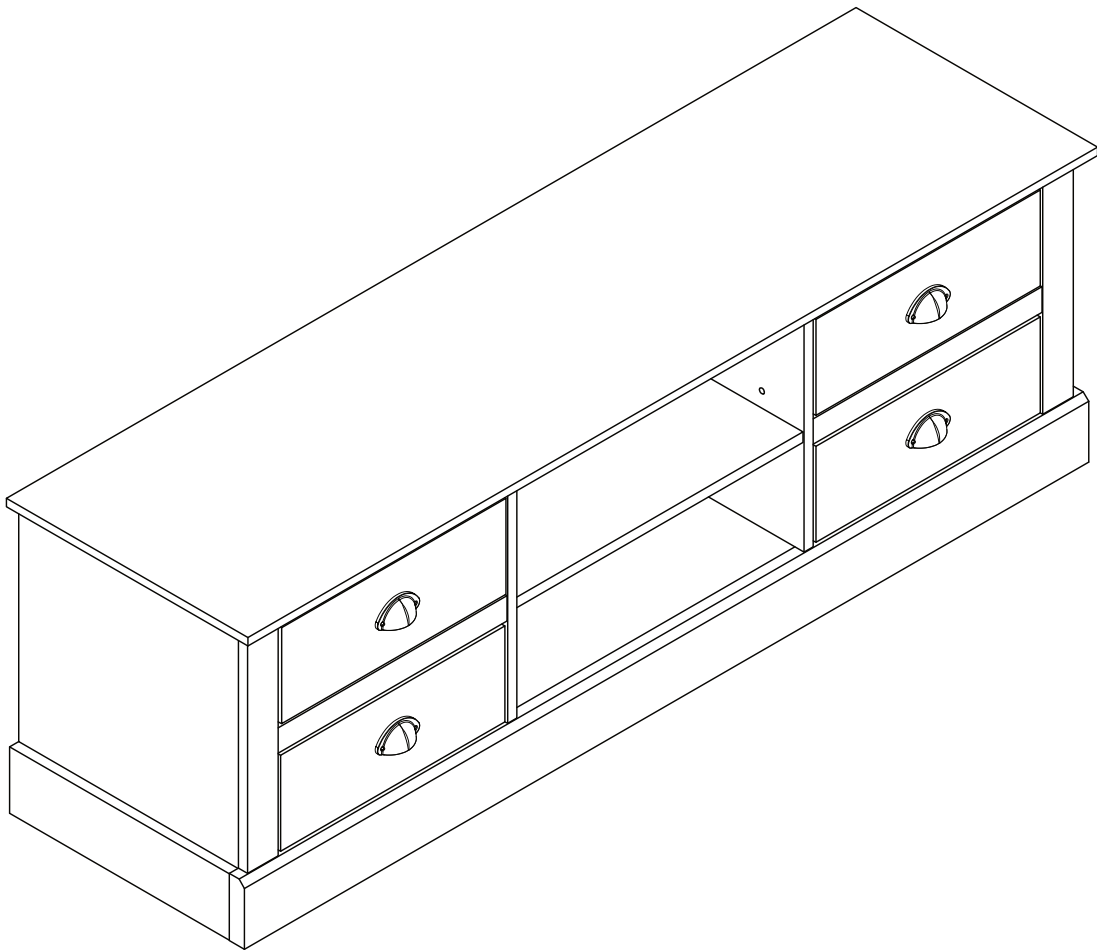

**ASSEMBLY INSTRUCTIONS / INSTRUCTIONS
D'ASSEMBLAGE / INSTRUCTIVO DE ARMADO**



FG-WH/LR-PU-7-429-RV-WYUK

NOTES ON ASSEMBLY / NOTES POUR L'ASSEMBLAGE / NOTAS SOBRE EL ENSAMBLE

- To ensure ease of assembly read all instructions before assembly and follow step by step illustrations.
- Keep instructions for future use.
- Adult assembly required.  2 person required. 
- Due to the presence of small parts during assembly, keep out of reach of children until assembly is complete.

- Pour assurer l'assemblage facile veuillez lire toutes les instructions avant l'assemblage et veuillez suivre les illustrations pour chaque étapes.
- Veuillez garder ces instructions pour l'usage ulterieur.
- Assemblage requis pas un adulte.  2 personnes requises. 
- Due a la presence de petite pieces durant l'assemblage, veuillez garder hors de porter des enfants jusqu'a ce que l'assemblage soit completer.

- Para garantizar la facilidad de ensamble lea las instrucciones antes de iniciar y siga paso a paso las ilustraciones.
- Guarde las instrucciones para futuras referencias.
- El ensamble requiere de un adulto.  2 personas requeridas. 
- Debido a que hay piezas pequeñas, mantenga fuera del alcance a los niños durante el ensamble, hasta que haya terminado.

MAINTENANCE TIPS / CONSEILS D'ENTRETIEN / CONSEJOS DE MANUTENIMIENTO

- Never let liquids or damp cloths sit on this furniture.
- Never use chemical cleaning products. They can damage the finish. For cleaning, use only a slightly damp cloth and wipe dry.
- To avoid dulling of the finish, do not place furniture in direct sunlight.
- Do not put plastic or rubber rings under appliances. Use cloth of felt protectors.
- To clean, use a soft or slightly damp cloth, then wipe with a clean, dry cloth.

- Ne jamais laisser de liquide ou linge humide sur le meuble.
- Ne jamais utiliser de nettoyeurs à base de produits chimiques, cela va endommager le fini. Utiliser seulement un linge légèrement humide.
- Ne pas placer le meuble directement au soleil pour prévenir le ternissement.
- Évitez de déposer des appareils avec des rondelles de plastique ou de caoutchouc. Utilisez un protecteur en tissu ou en feutre.
- Pour nettoyer, utilisez un linge doux ou légèrement humecté. Essuyez par la suite avec un linge propre et sec.

- Nunca deje un líquido o un trapo húmedo sobre el mueble.
- Nunca utilice limpiadores a base de químicos, estos dañaran le acabado. Use sólo un paño húmedo.
- No esponga el mueble directamente al sol para prevenir empañamiento.
- Evite apoyar aparatos con redondeles de plástico o de goma. Utilizar un protector de tela o de fieltro.
- Para limpiar, utilice un trapo suave o ligeramente humedecido. Seque luego con un trapo limpio y seco.

WARNING AVERTISSEMENT / ADVERTENCIA

Please use your furniture correctly and safely. Improper use can cause safety hazards, or damage to your furniture or household items.

Serious or fatal crushing injuries can occur from furniture tip-over.

To help prevent tip-over:

- It is important to place the safety bracket included.
- Place heaviest items in the lowest storage space.
- Never allow children to climb or hang on drawers, doors, or shelves.
- Never open more than one drawer at a time.
- If a heavy object is placed on top or inside the furniture, consider this risk.

Use of tip-over restraints reduce, but does not eliminate, the risk of tip-over.

Prière d'utiliser le mobilier à bon escient et avec prudence. Une mauvaise utilisation peut être à l'origine de risques d'accident ou peut endommager le mobilier et les articles ménagers.

Des blessures graves ou fatales peuvent résulter de basculement du meuble.

Afin de prévenir le basculement :

- Il est important d'installer le crochet de sécurité inclus.
- Placer les items les plus lourds dans les espaces de rangement du bas.
- Ne jamais laisser un enfant grimper sur les tiroirs, les portes et les tablettes ou s'accrocher à ceux-ci.
- Ne jamais ouvrir plus d'un tiroir à la fois.
- Si un objet lourd est placé sur l'unité ou à l'intérieur, considérez le risque de basculement.

L'utilisation de dispositif antibasculement ne peut que réduire les risques de basculement, sans les éliminer

Por favor use el mobiliario correcta y seguramente. El mal uso puede causar riesgos de seguridad o daño a las unidades o artículos domésticos.

El vuelco del mueble puede ser causa de lesiones graves o de un aplastamiento fatal.

Para evitar la volcadura:

- Es importante instalar el gancho de seguridad.
- Ponga las cosas pesadas en los compartimentos más bajos.
- Nunca permita que un niño se suba o se cuelgue en cajones, puertas o estantes.
- Nunca abra más de un cajón a la vez.
- Si un objeto pesado esta colocado dentro o sobre el mueble, considere el riesgo de que se puede voltear.

El uso de sujetadores para evitar el vuelco sólo puede disminuir el riesgo de un vuelco, pero no lo elimina.

**MINIFIX CAM & MINIFIX BOLT
CAMÉRA MINIFIX & BOULON MINIFIX
CÁMARA MINIFIX & PERNO MINIFIX**

**MINIFIX BOLT
BOULON MINIFIX
PERNO MINIFIX**





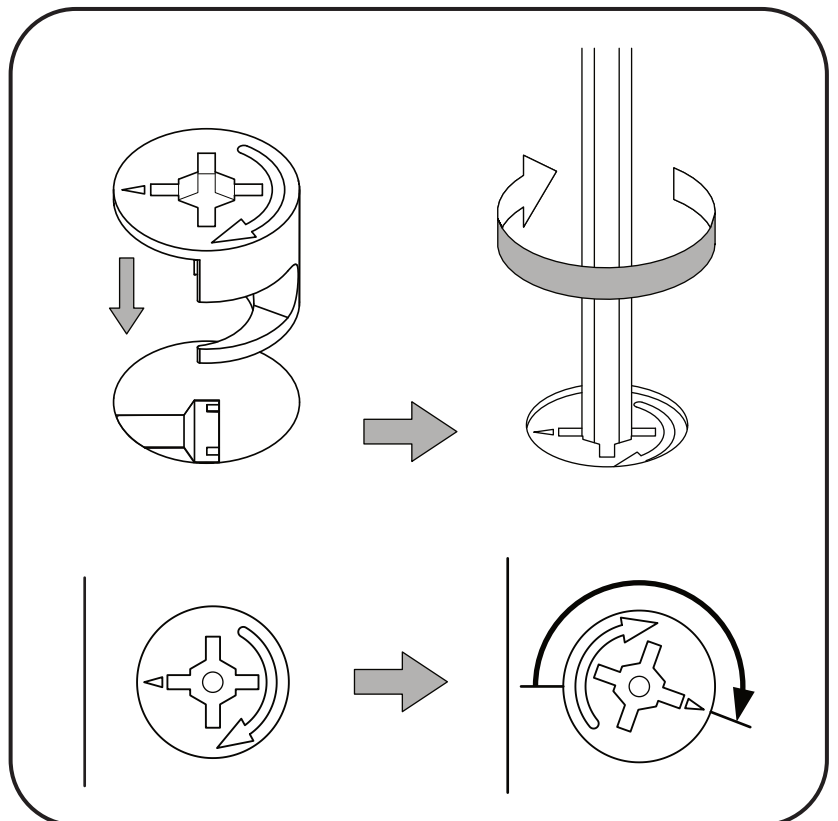

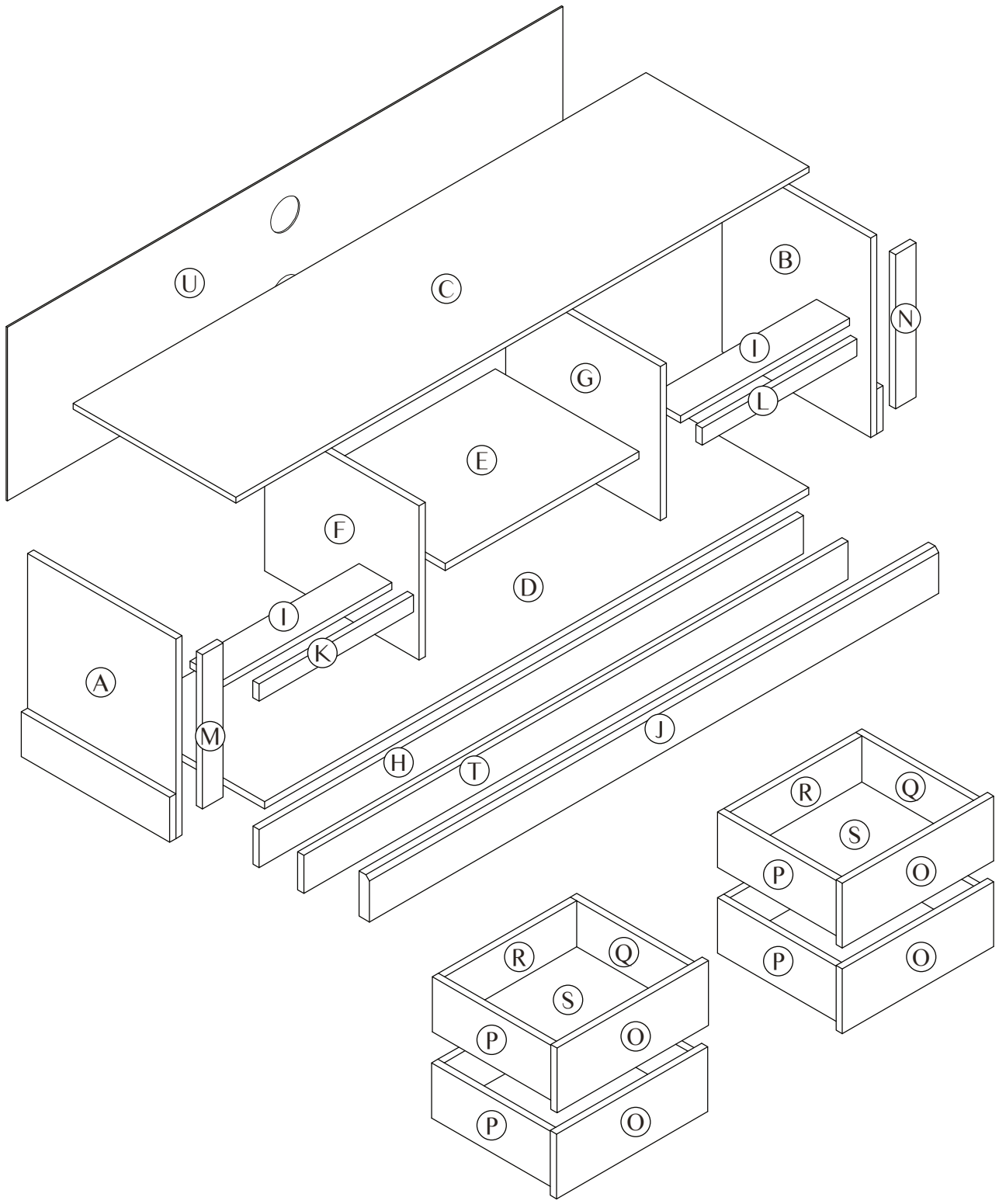







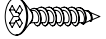



**MINIFIX CAM
CAMÉRA MINIFIX
CÁMARA MINIFIX**





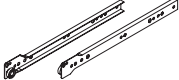
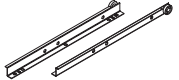
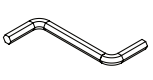

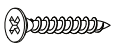
HARDWARE QUINCAILLERIE / HERRAJE

(A)	Screw M6.3 x 40mm  4 units	(B)	Screw M4 x 38mm  16 units	(C)	Minifix Bolt EU 24  34 units
(D)	Dowel M8 x 30mm  46 units	(E)	Screw #6 x 16mm  8 units	(F)	Screw M4 x 20mm  16 units
(G)	Screw M3.5 x 15mm  32 units	(H)	Screw M6 x 8mm  8 units	(I)	Shelf Support  4 units
(J)	Nail Pin  16 units	(K)	Nail Leg  8 units	(L)	Minifix Cam 15/12  34 units
(M)	Handle L-82mm/ H-64mm  4 units	(N)	L Bracket  4 units	(O)	PVC Block  8 units
(P)	Drawer Slide 300mm  4 sets	(Q)	Drawer Slide 300mm  4 sets	(R)	Allen Key Z (M4)  1 unit
(S)	Safety Strap + Washer  1 unit	(T)	Screw M3.5 x 25mm  1 unit		

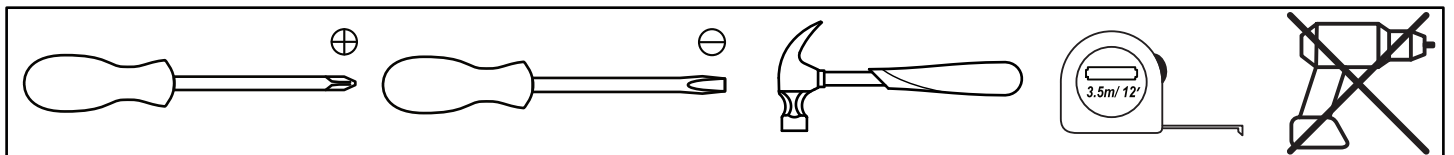
**TOOLS NOT INCLUDED
OUTILS PAS INCLUS / HERRAMIENTAS NO INCLUIDAS**



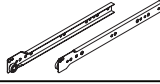

STEP 1

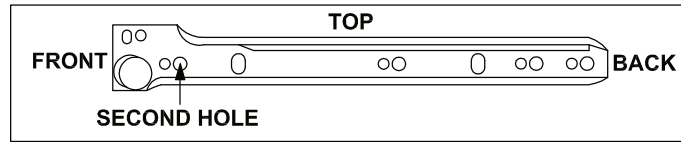
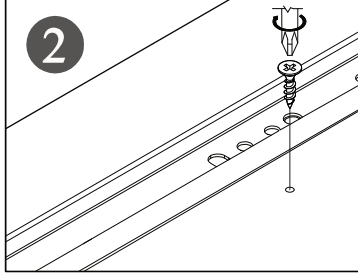
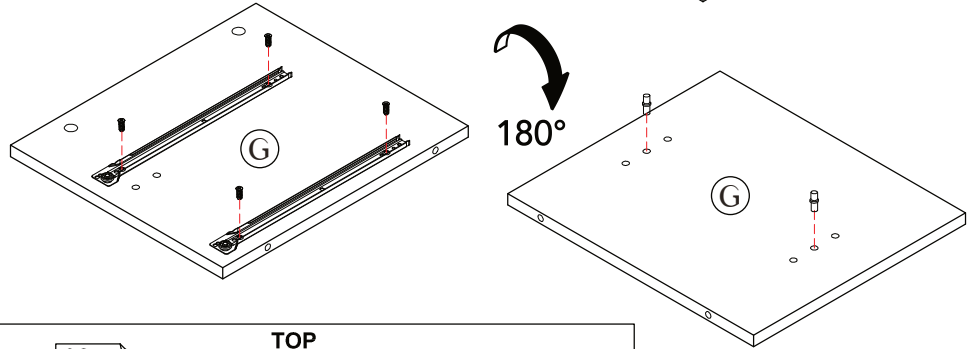
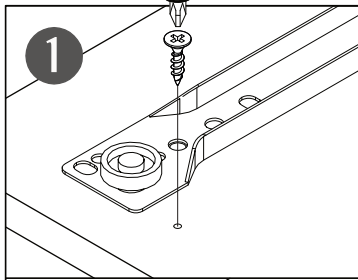
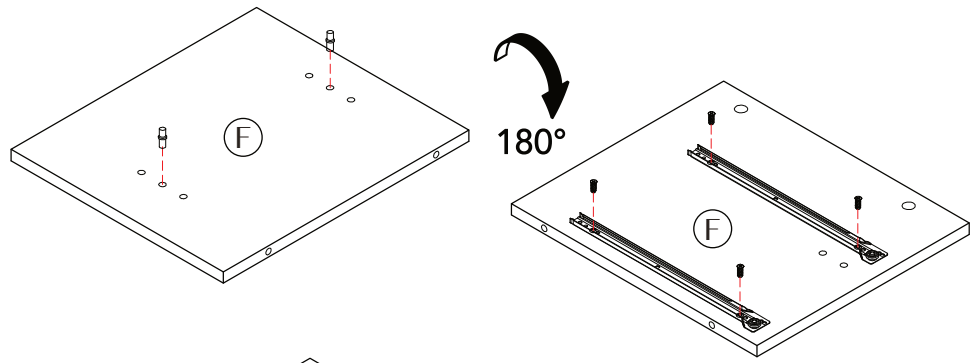
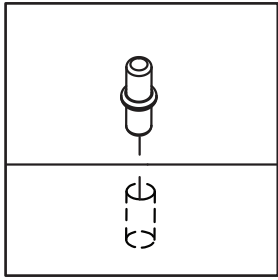
		
P x 2	I x 4	H x 8





PLEASE ENSURE TO FIX THE SCREWS AS PER ABOVE POINTED HOLES INSTRUCTION TO AVOID DISTORTION OF OVERALL LOOK OF PRODUCTS

STEP 2

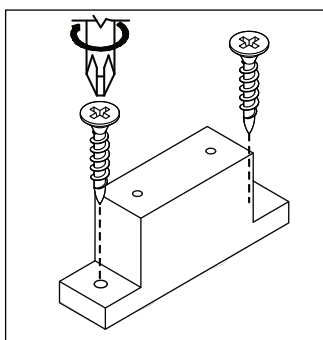
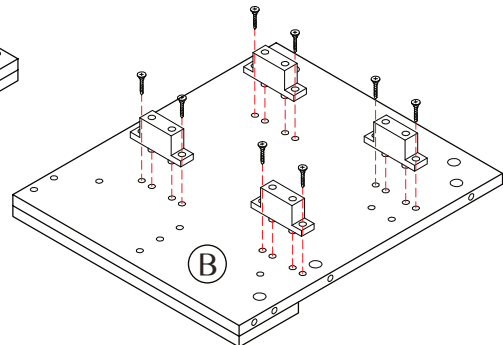
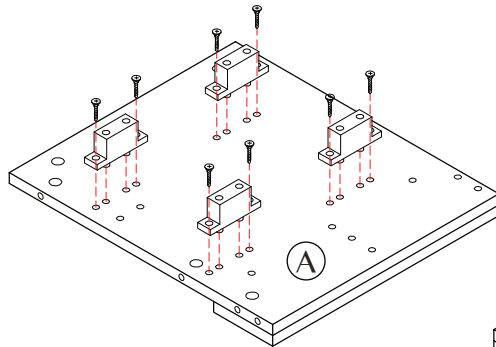
	
O x 8	F x 16

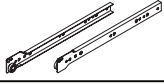

STEP 3

	
P x 2	G x 8

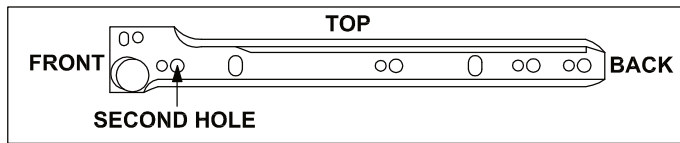
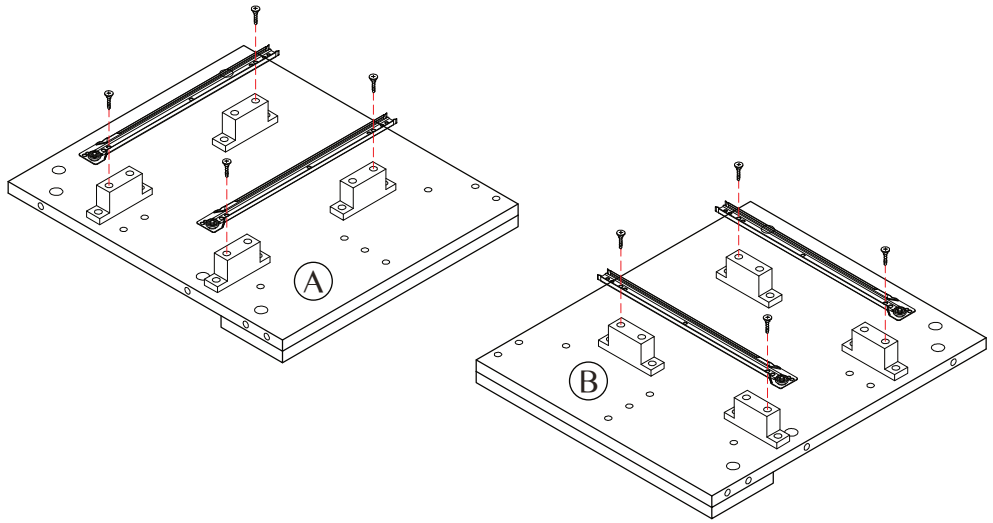
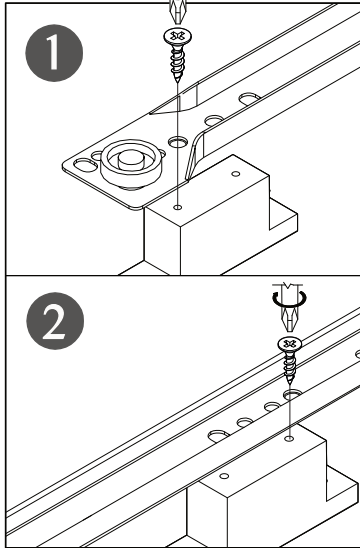



PLEASE ENSURE TO FIX THE SCREWS AS PER ABOVE POINTED HOLES INSTRUCTION TO AVOID DISTORTION OF OVERALL LOOK OF PRODUCTS

STEP 4

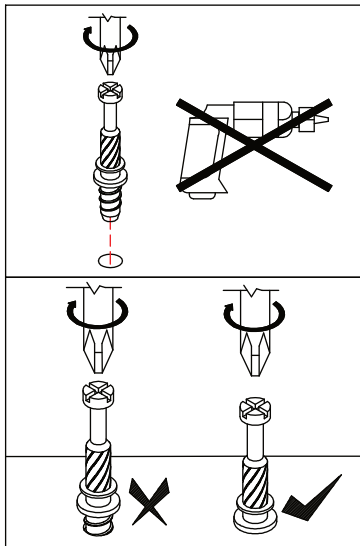
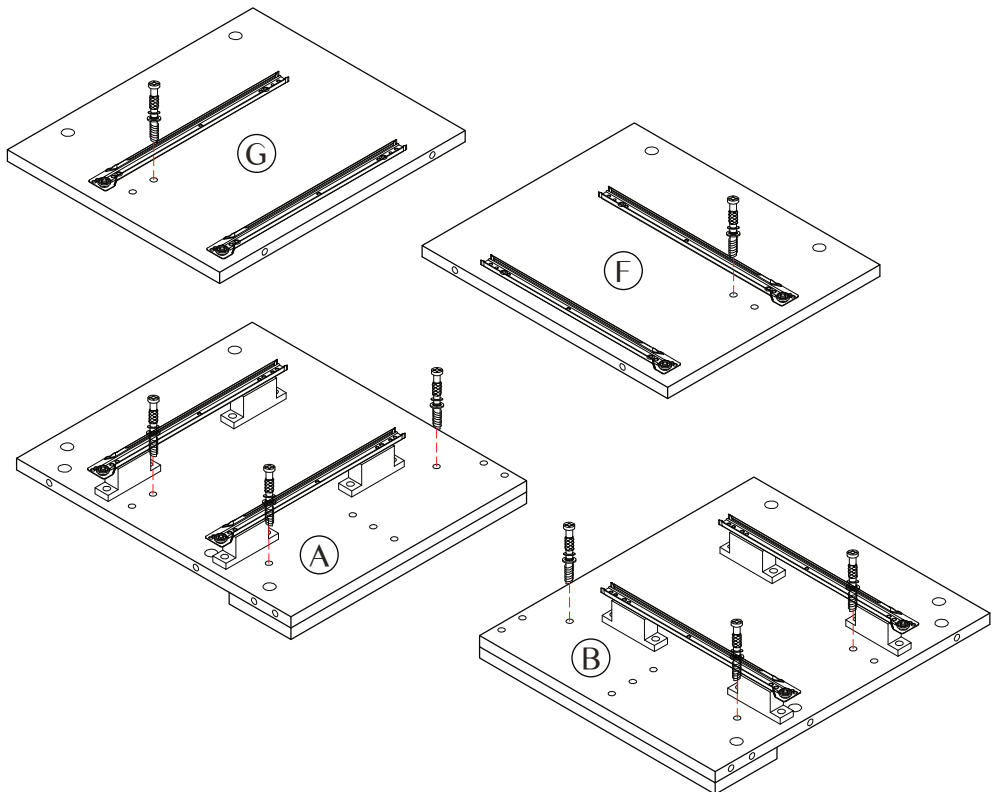
C x 8



STEP 5

	
G x 2	N x 2

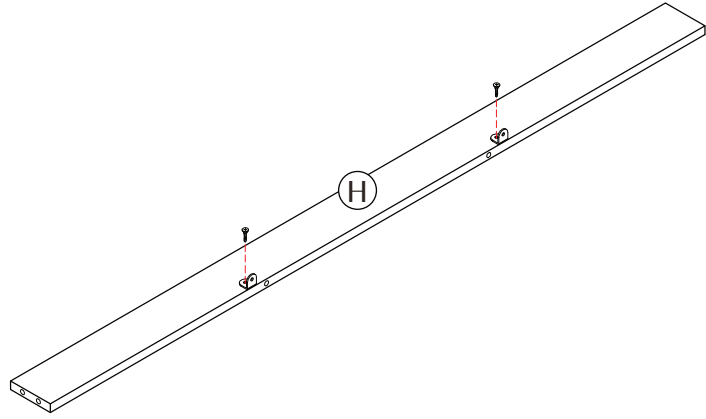
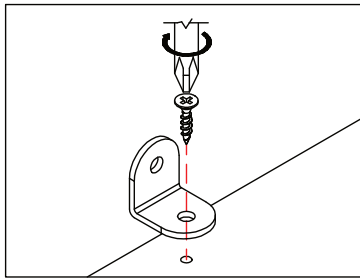

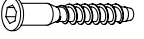

STEP 6

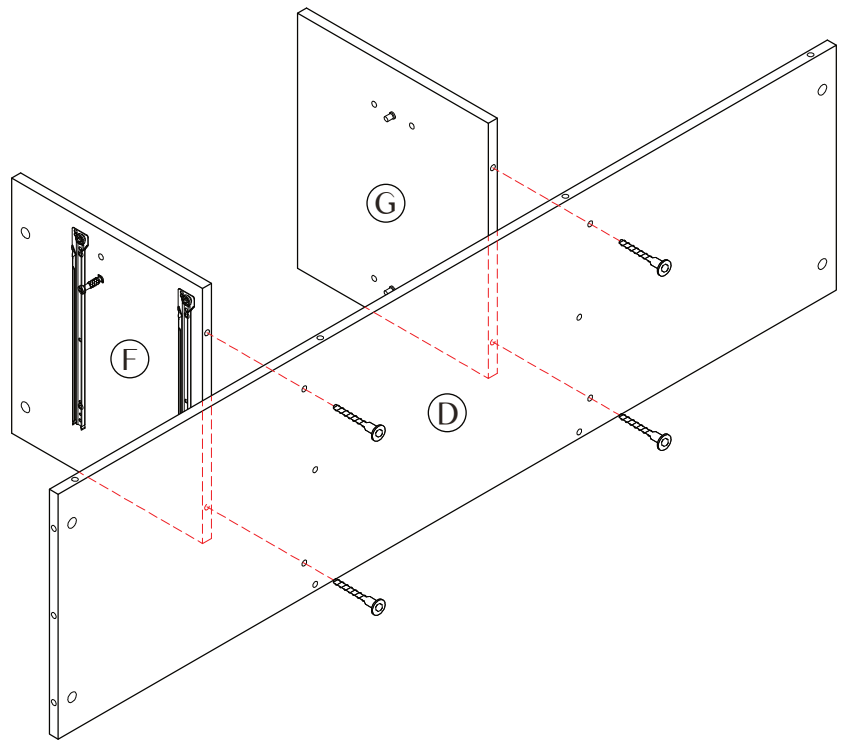
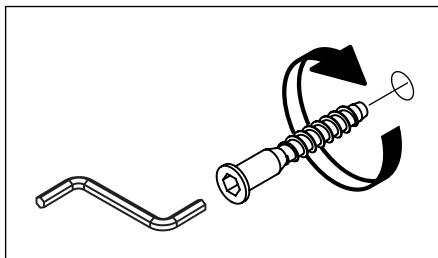
A x 4



STEP 7

	
G x 2	D x 6

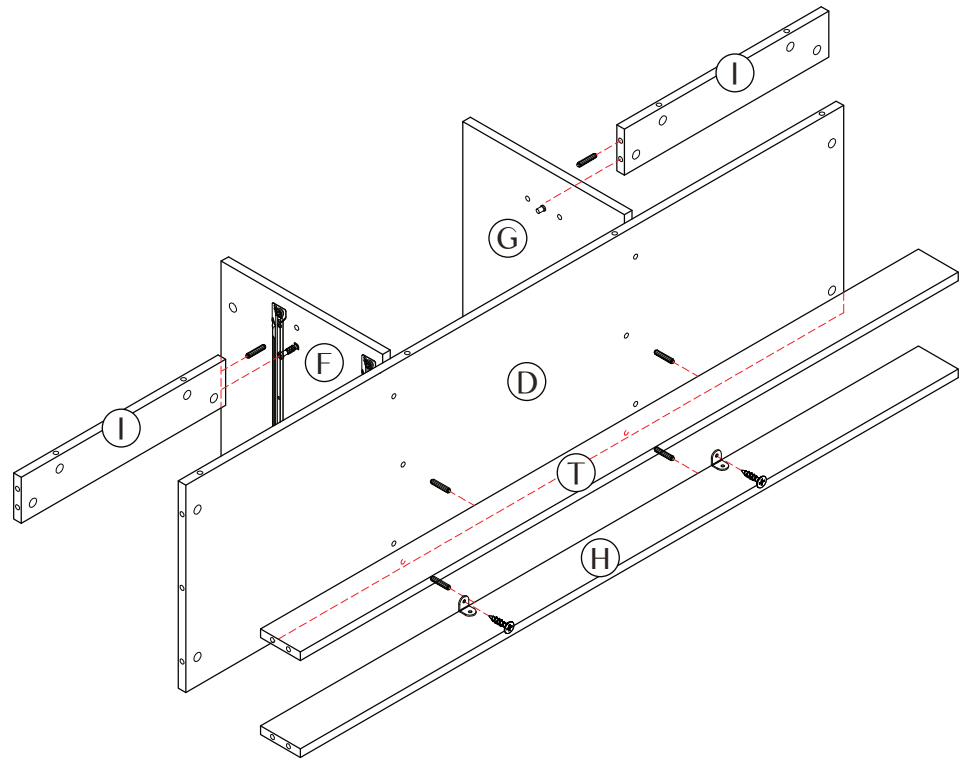
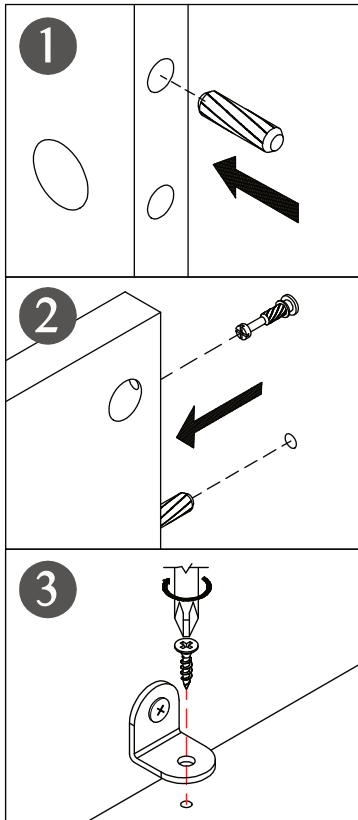

STEP 8

D x 12

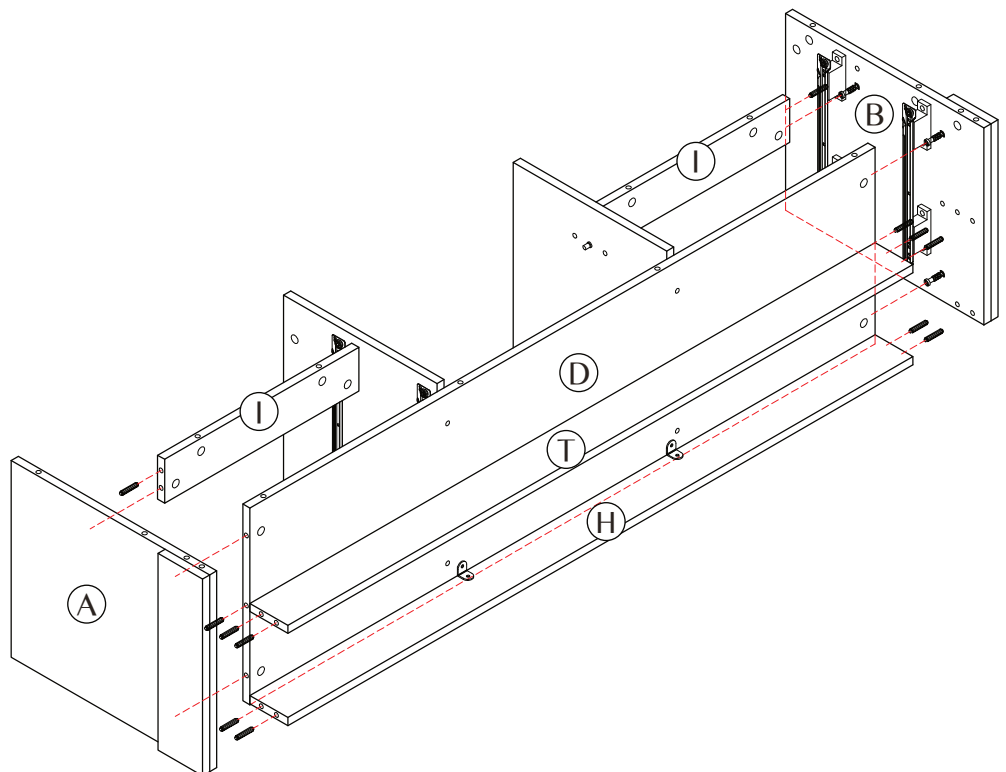
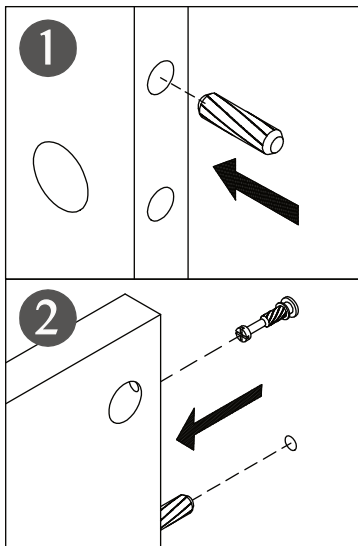

STEP 9

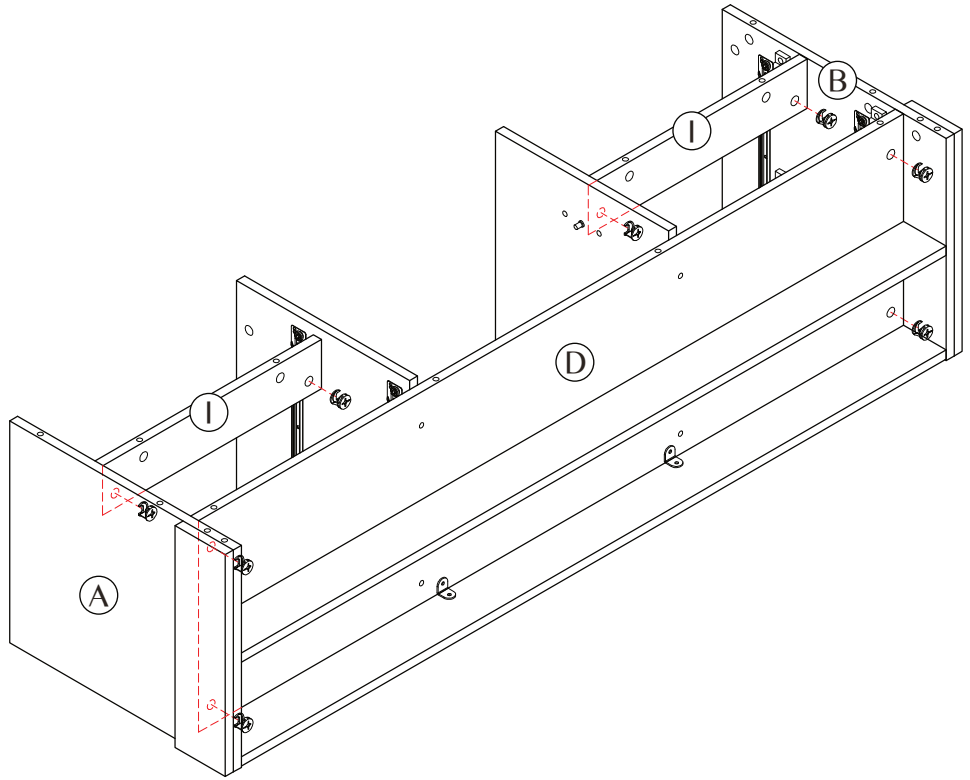
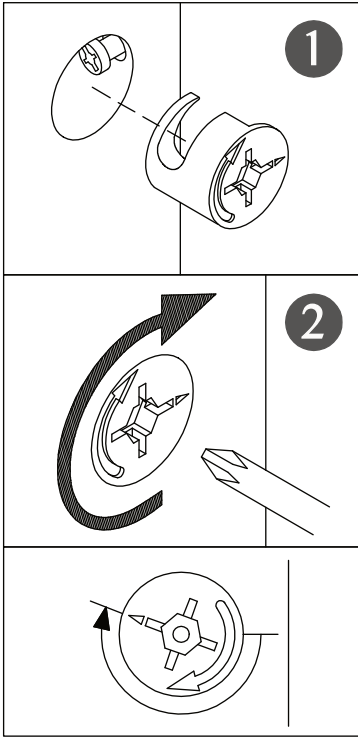
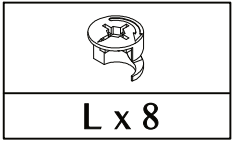

STEP 10

G x 2	N x 2	C x 10

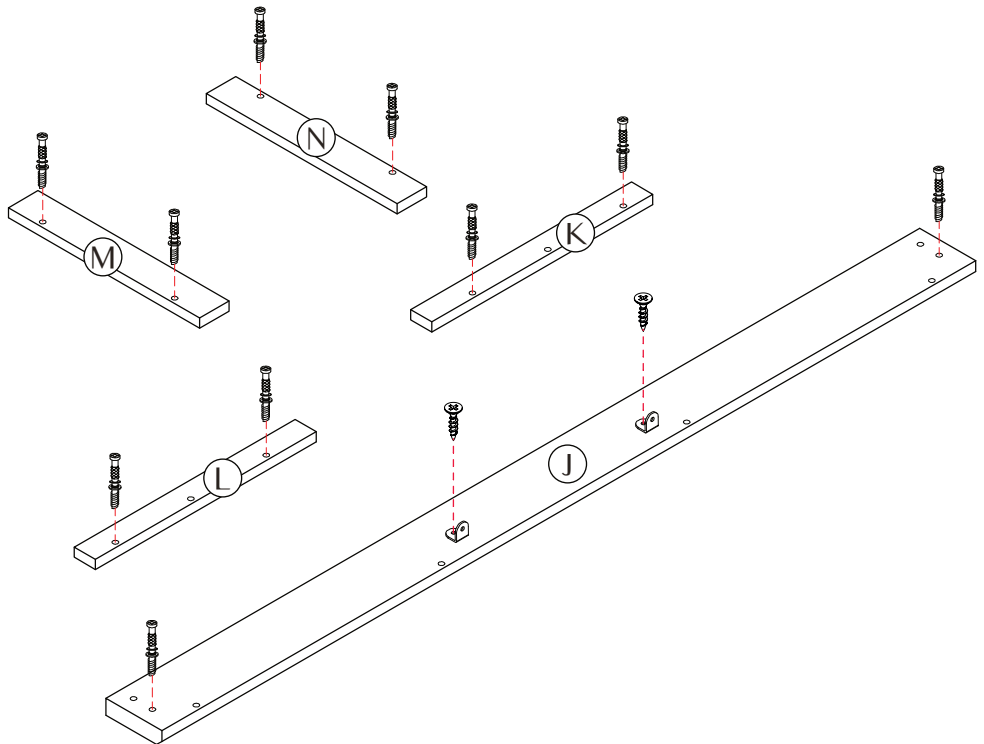
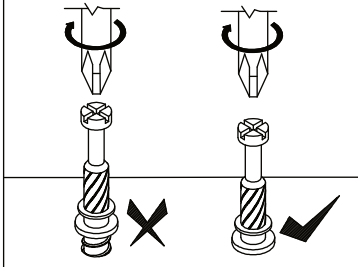
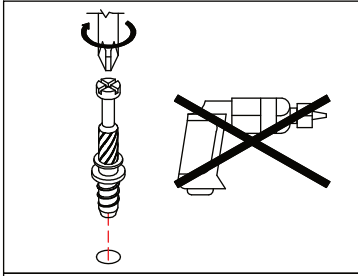
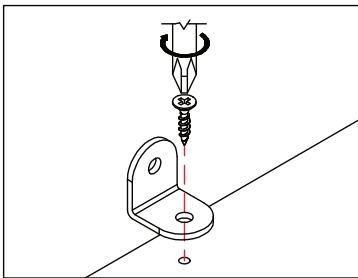

STEP 11

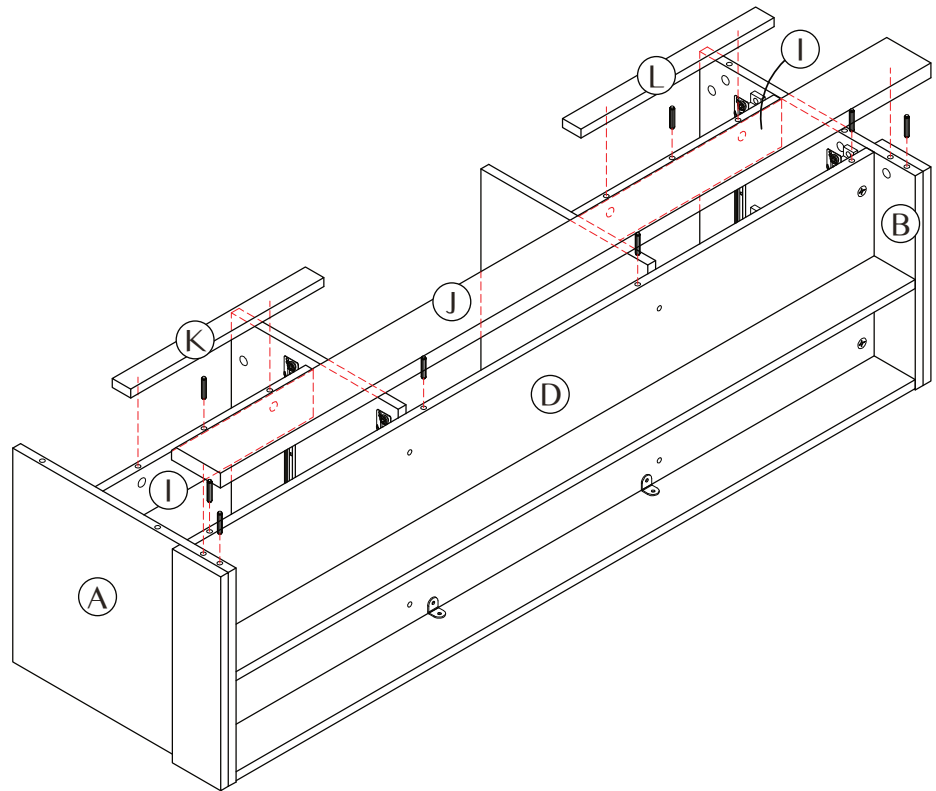
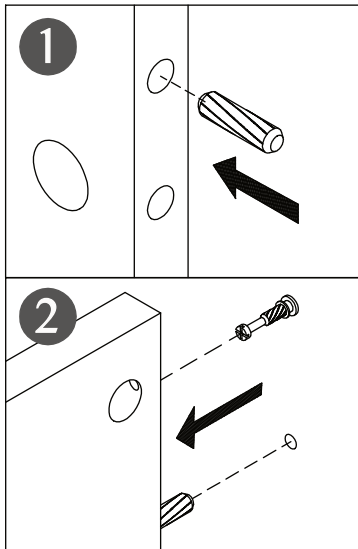
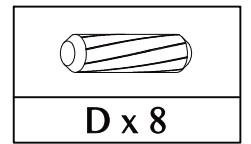

STEP 12

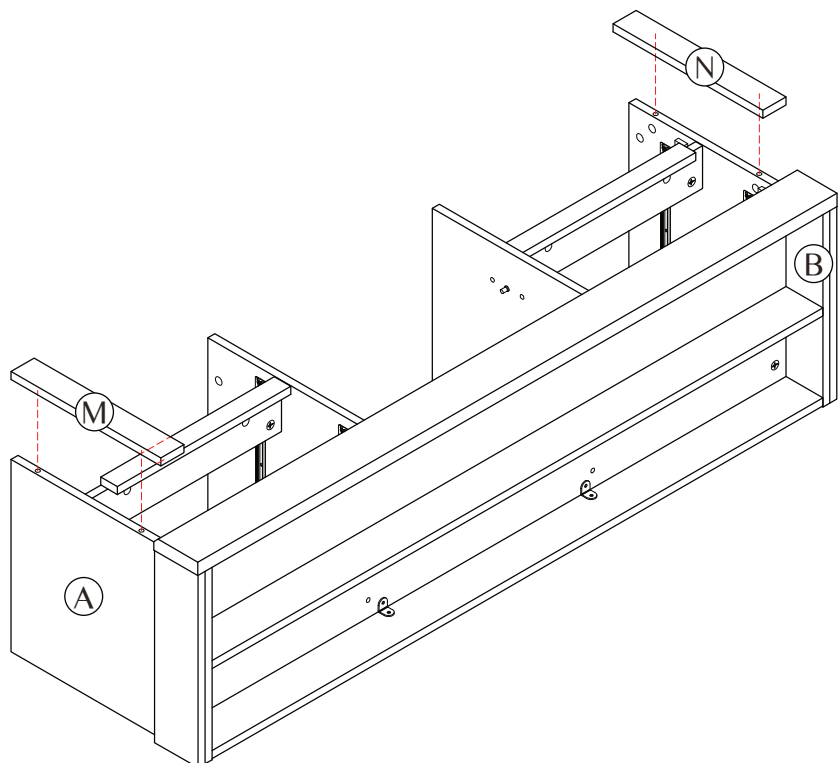
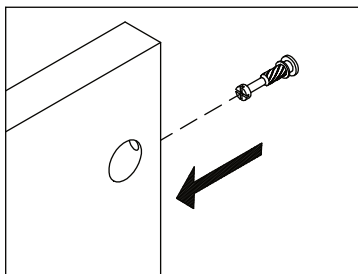

STEP 13

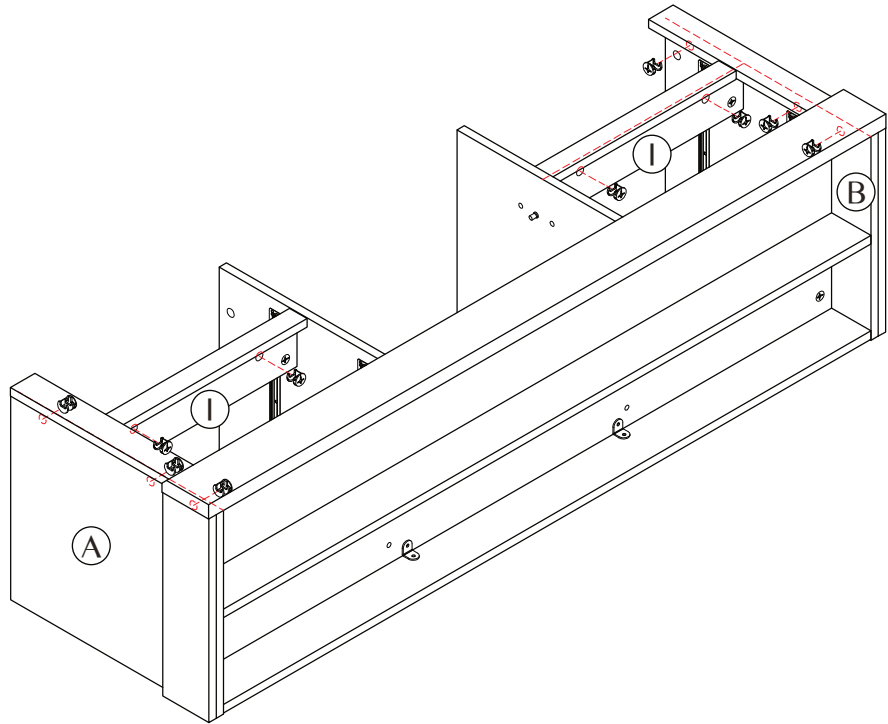
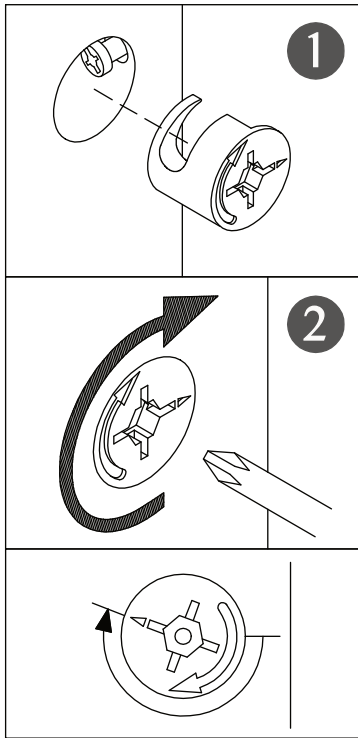
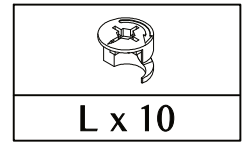

STEP 14

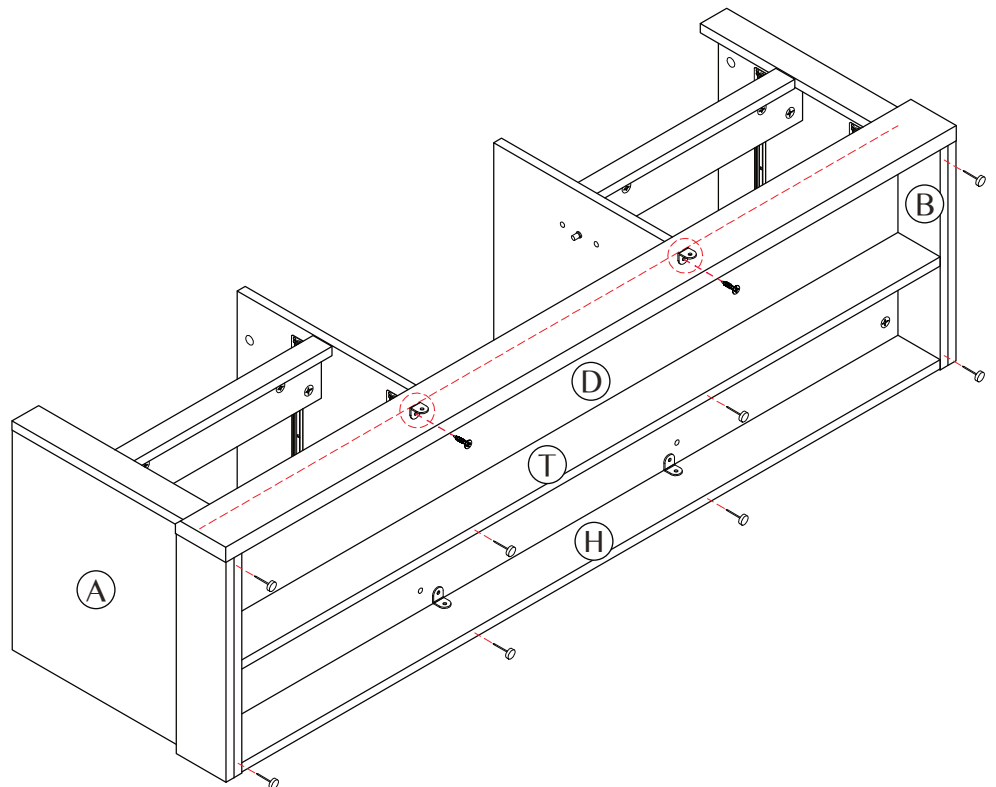
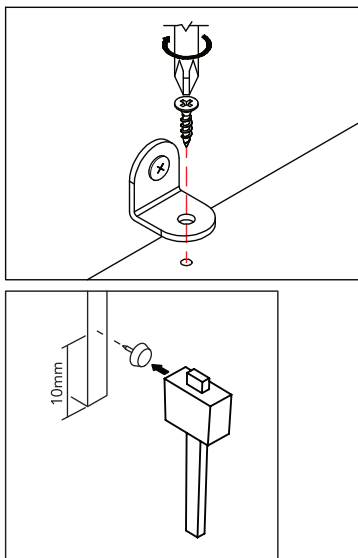
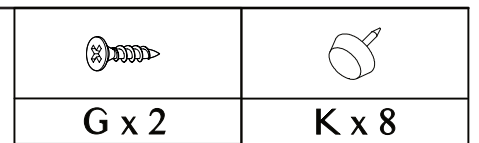

STEP 15

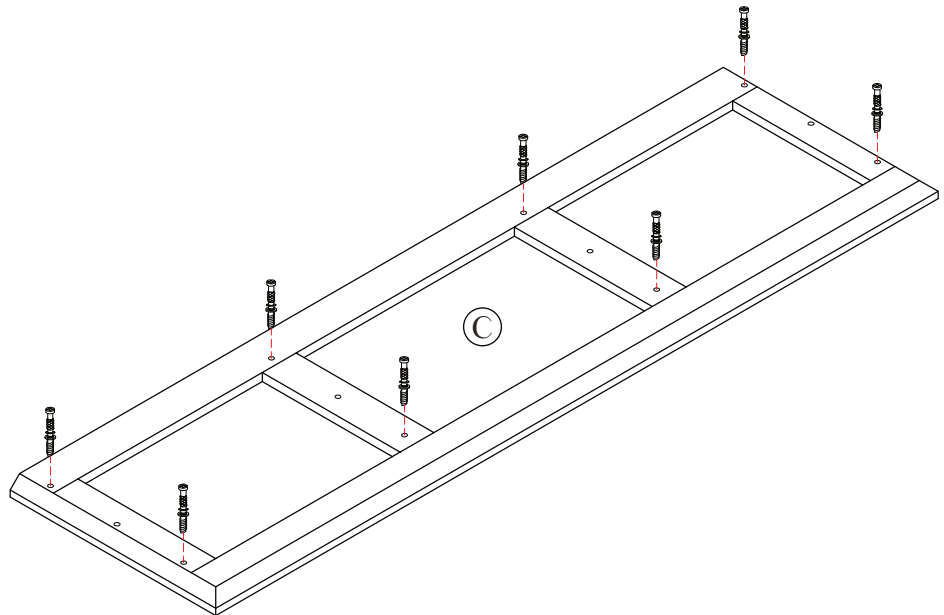
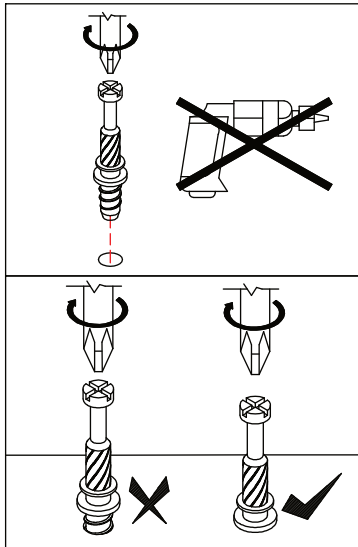
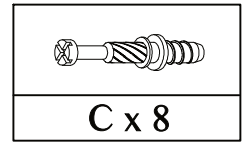

STEP 16

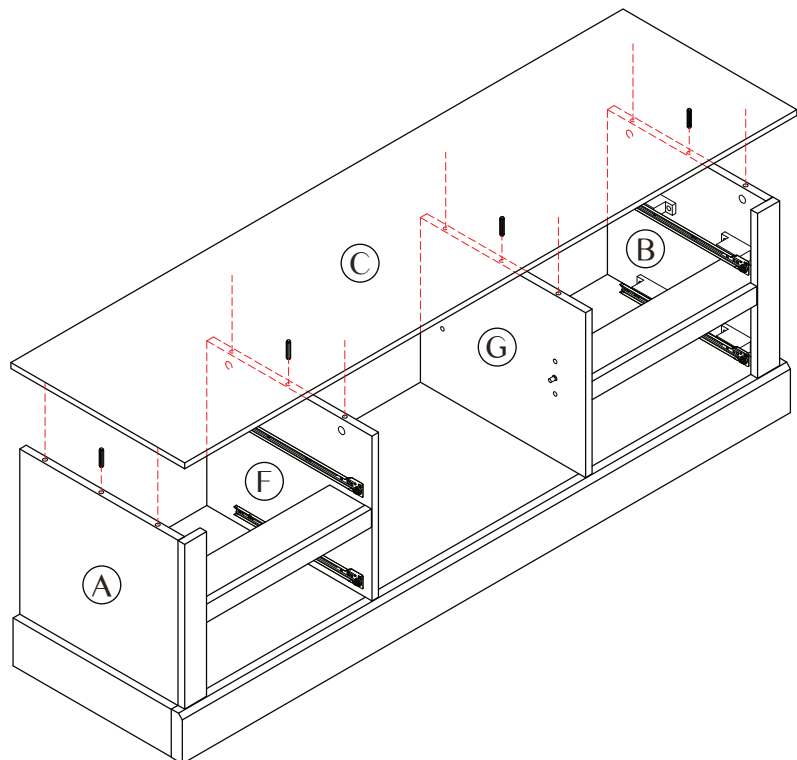
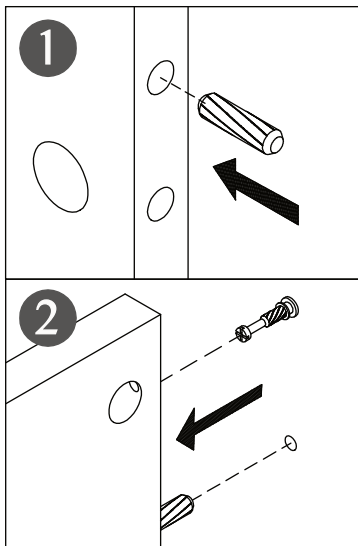
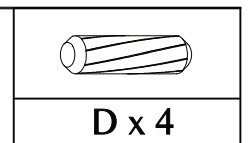

STEP 17

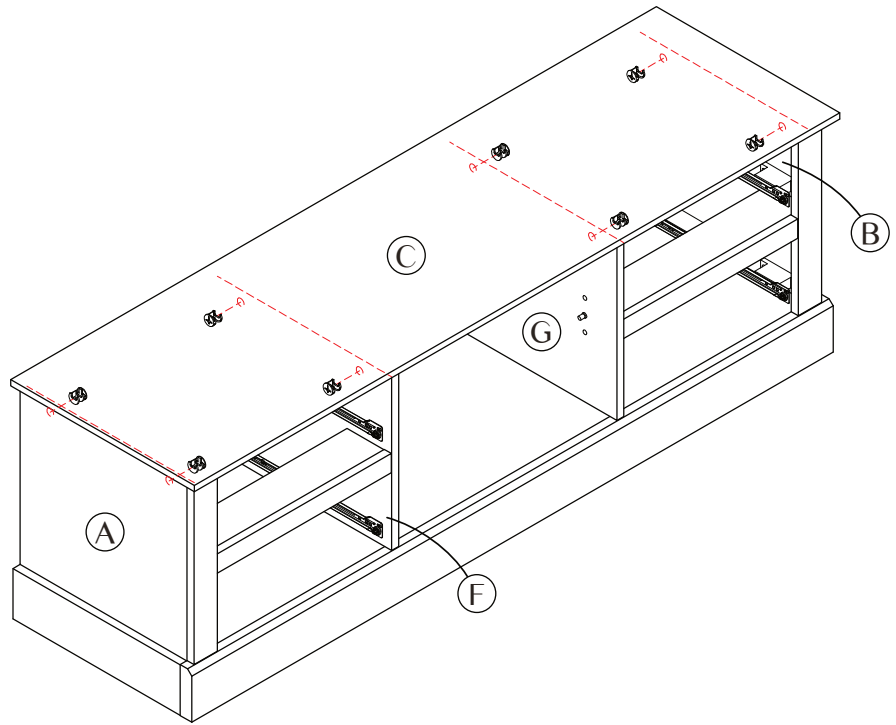
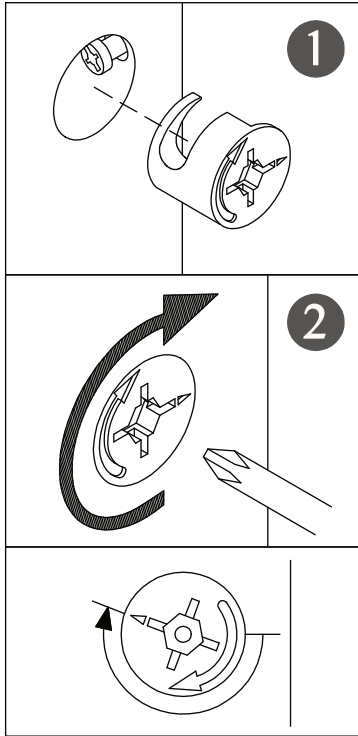
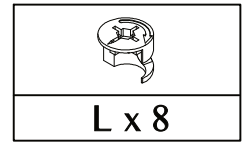

STEP 18

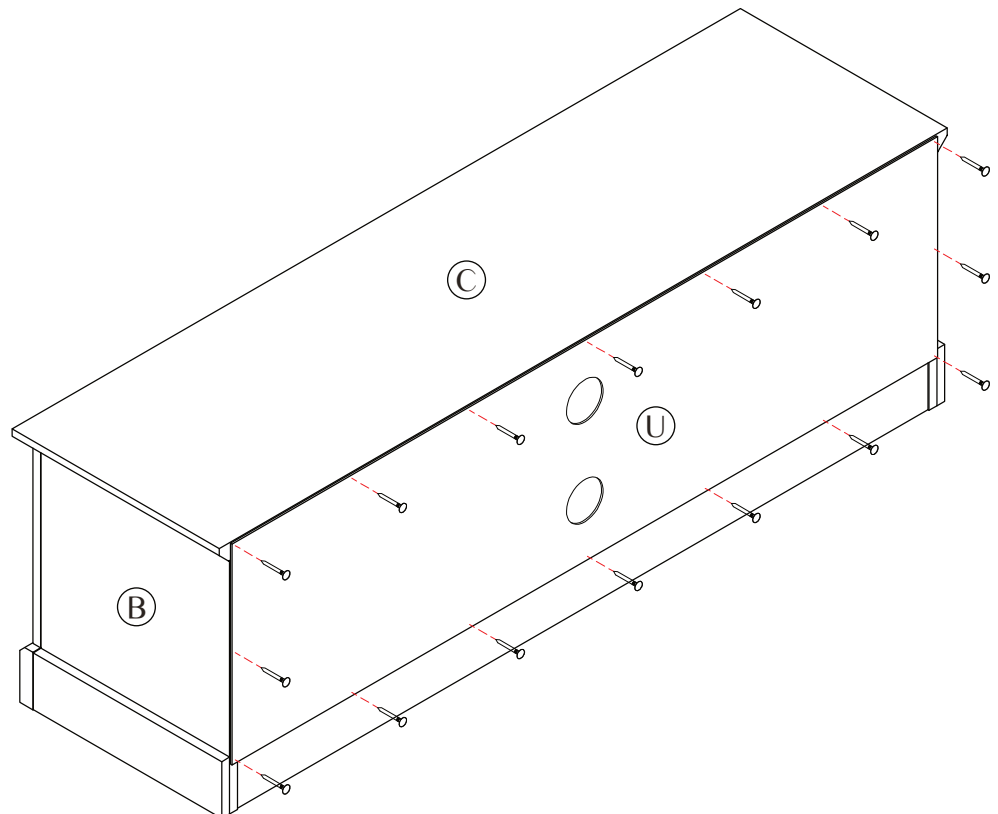
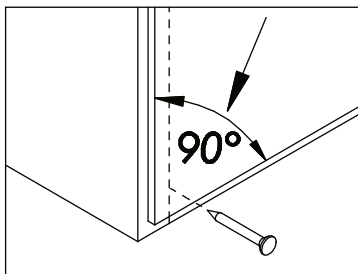
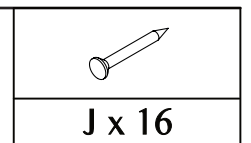

STEP 19

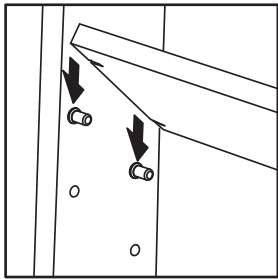
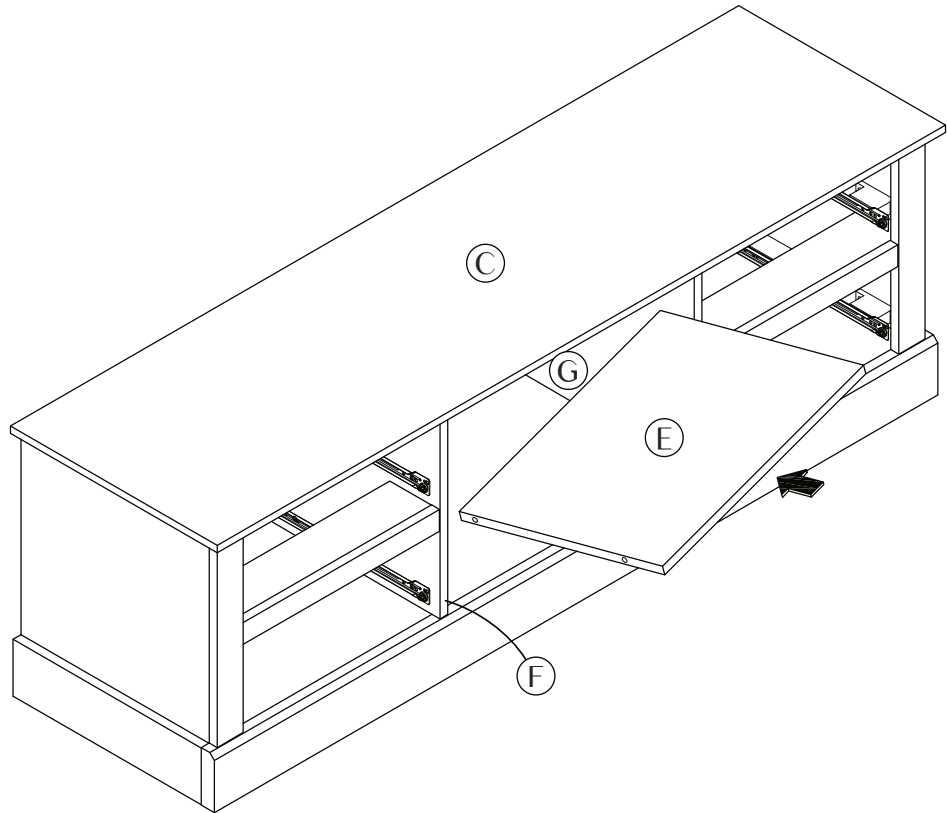

STEP 20

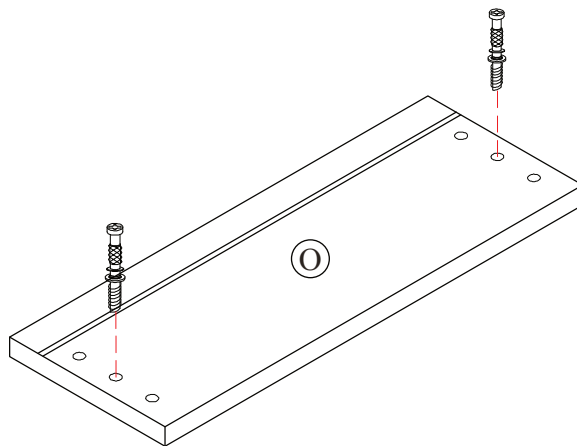
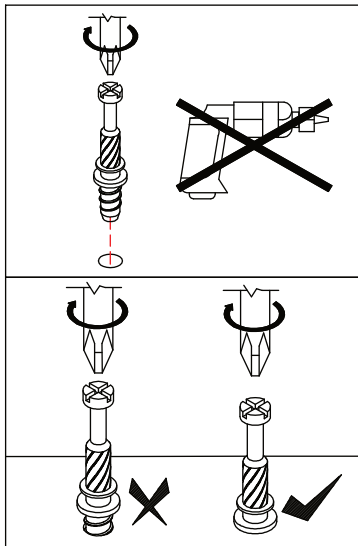
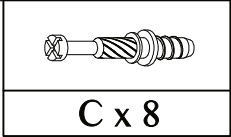

(4x)

STEP 21

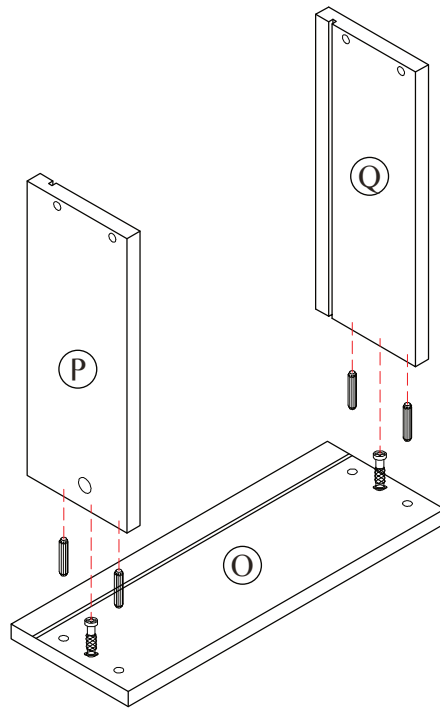
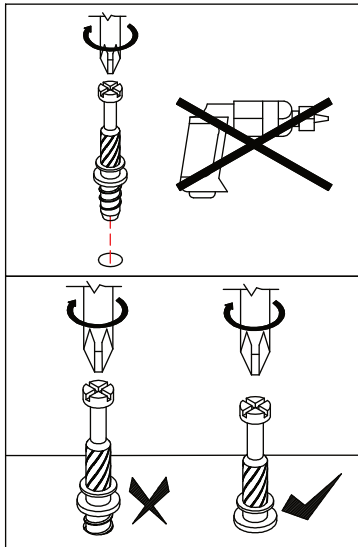
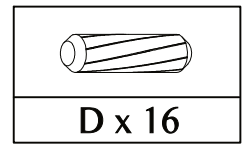

(4x)

STEP 22

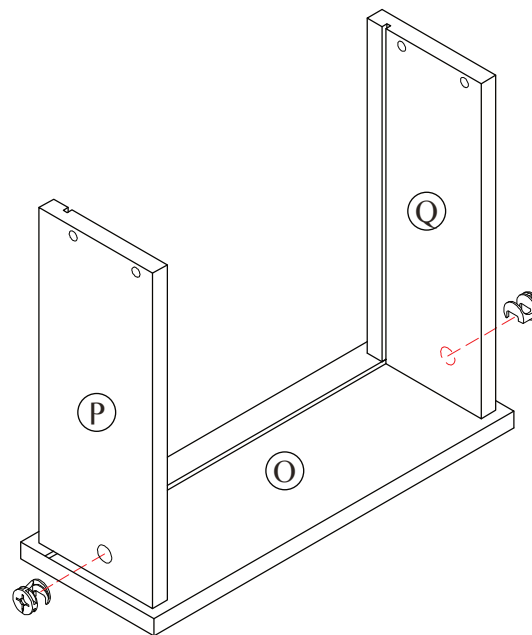
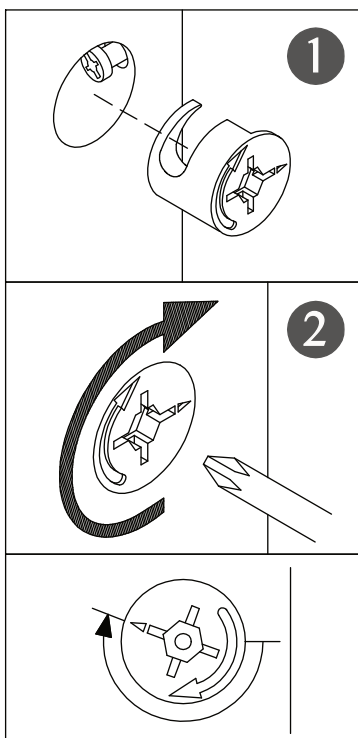
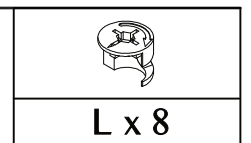

(4x)

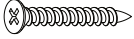

STEP 23

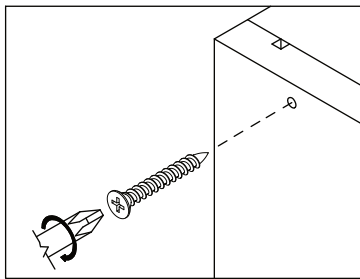
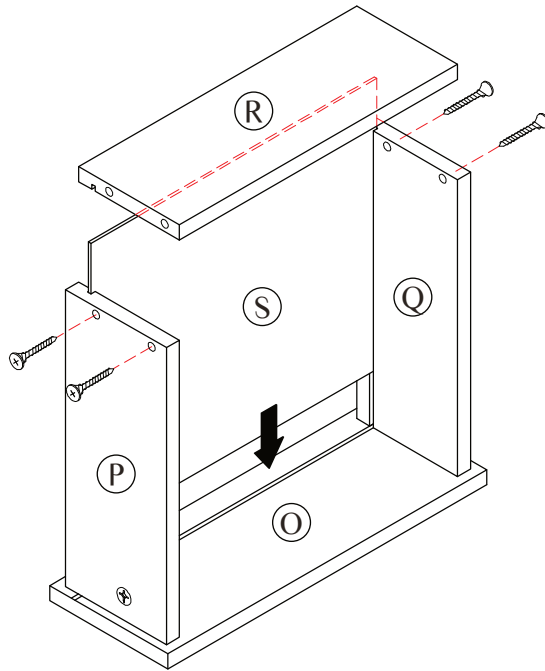

B x 16



(4x)

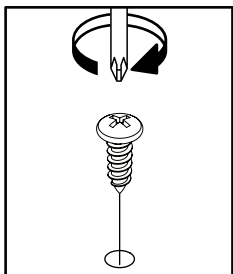
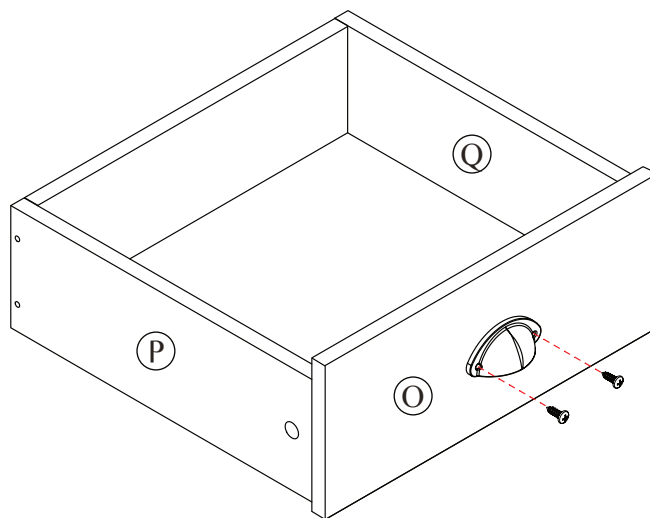

STEP 24

	
E x 8	M x 4



(4x)

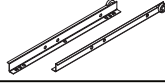

STEP 25

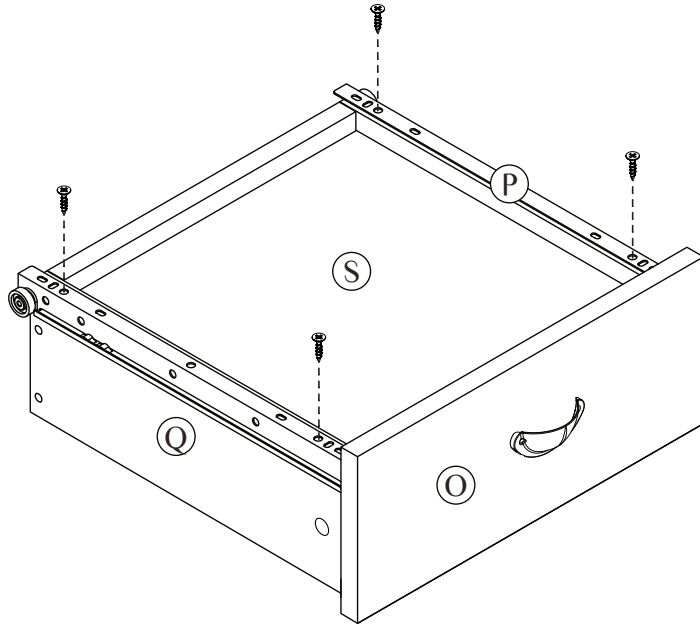
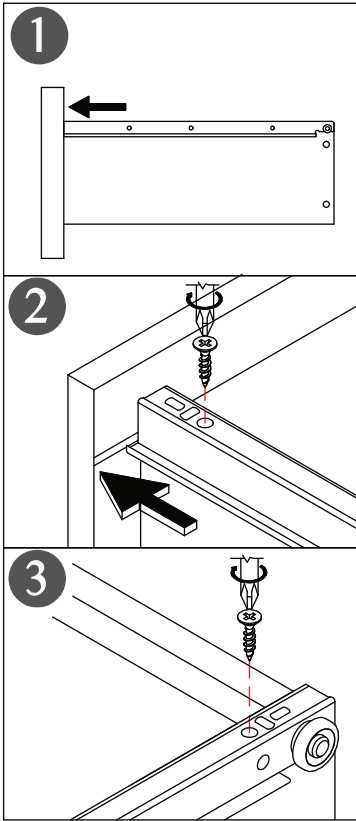
	
Q x 4	G x 16



(4x)

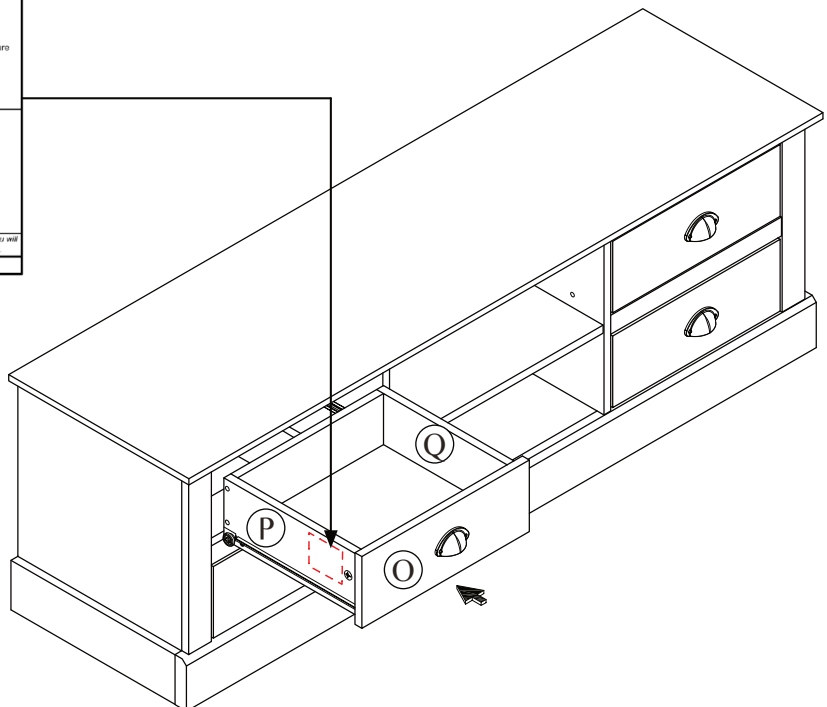
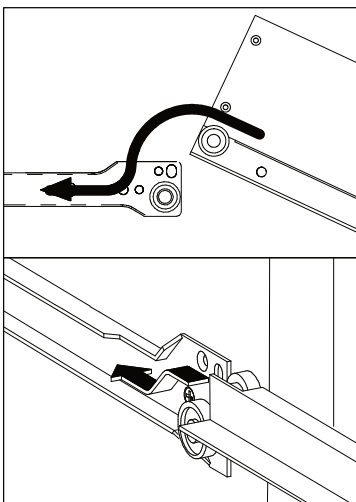

STEP 26

	WARNING!
	<p>In order to help prevent overturning, this product must be used with the wall anti-tip/ device provided.</p> <ul style="list-style-type: none"> Furniture can tip and cause injuries to persons. Please use anti-tip strap/ device provided. NEVER allow children to stand, climb or hang on drawers, doors, or shelves. Do not place heavy items on top of furniture unless the furniture has been designated for this purpose.
	<p>Please ignore if furniture without drawer:</p> <p>Furniture with Drawer's :-</p> <ul style="list-style-type: none"> Place heaviest items in the lowest drawers. Never open more than one drawer at a time. Do not place heavy items in the top drawer.
<p><small>Please note that only anti-tip straps/devices and screw are provided, you will need to provide wall plugs and screw applicable for your wall type.</small></p> <p>This is permanent label. Please do not remove!</p>	

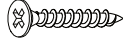

(4x)

STEP 27

	
T x 1	S x 1

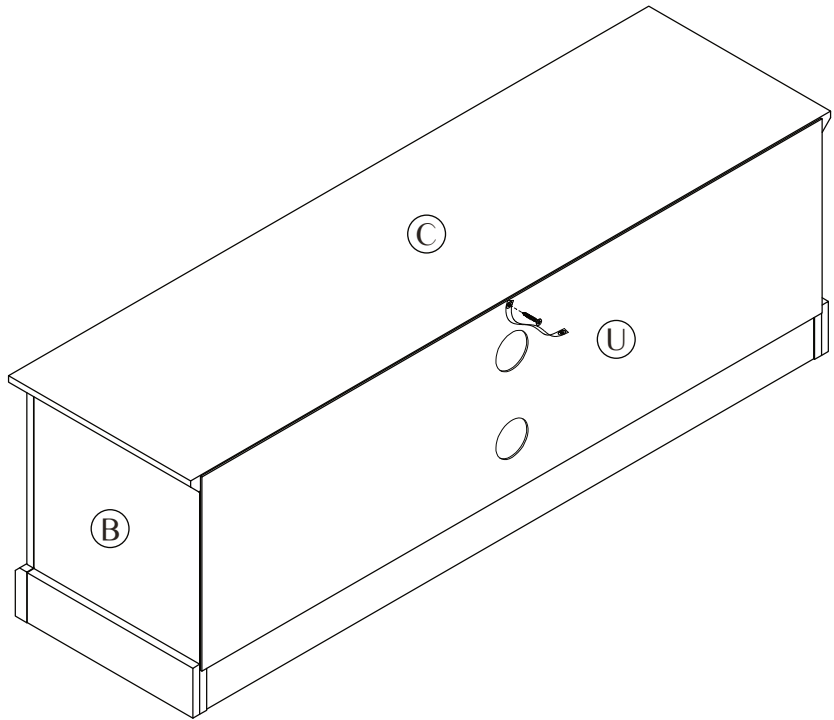
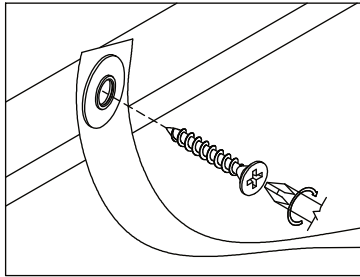

STEP 28

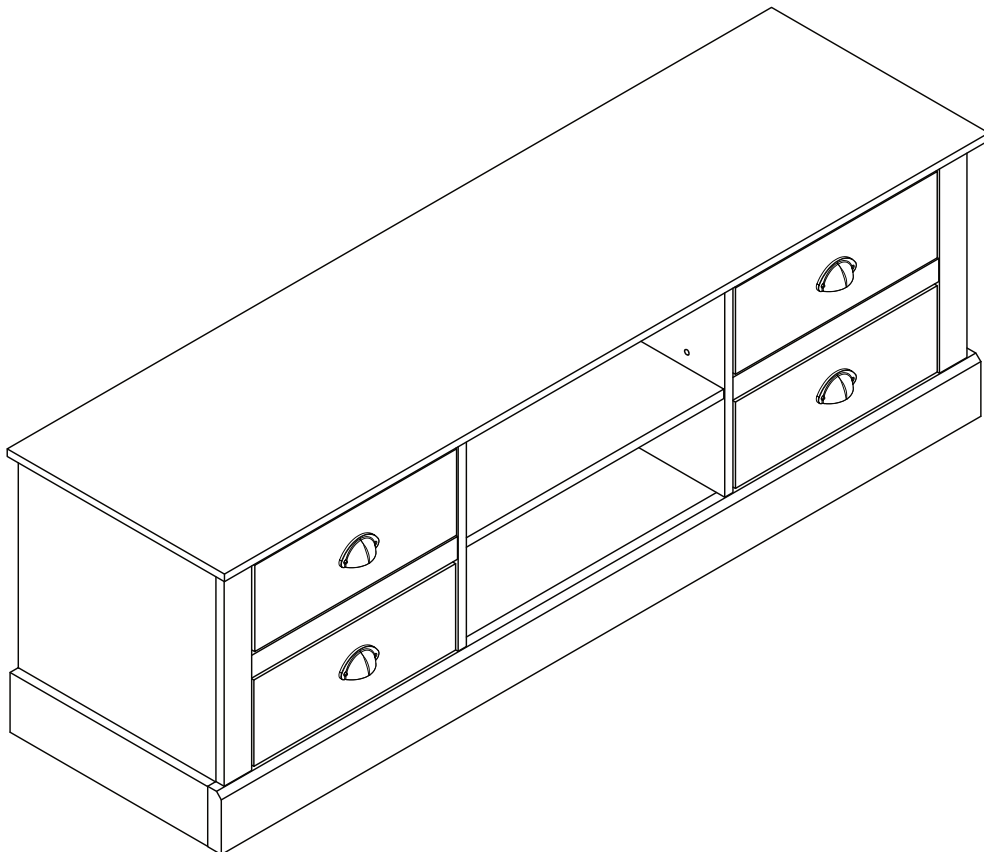

FITTING OF ANTI-TOPPLE SAFETY STRAP

MONTAGE DE LA SANGLE DE SÉCURITÉ

ANTI-RENVERSEMENT

COLOCACIÓN CORREA DE SEGURIDAD ANTI-TOPPLE

STEP 1:

Fix screw through safety strap hole on the top panel of your furniture.

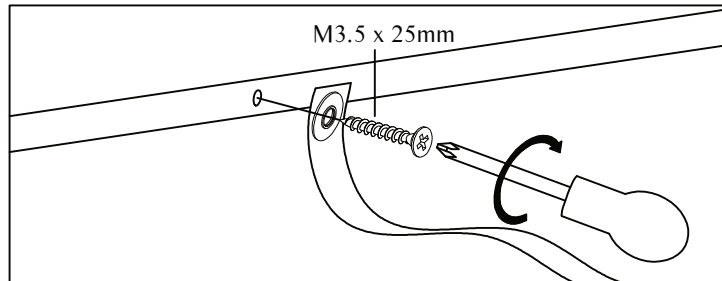

STEP 2:

Drill a hole on the wall and insert the wall plug.

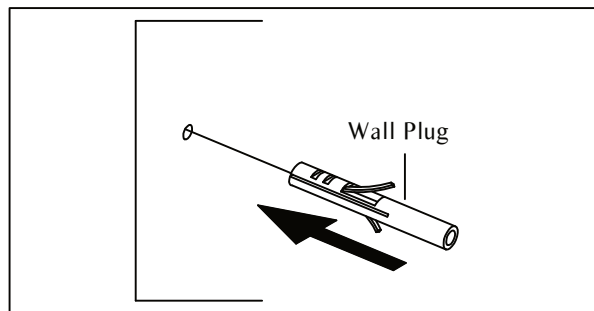

STEP 3:

Fix screw through the safety strap in the wall plug hole.

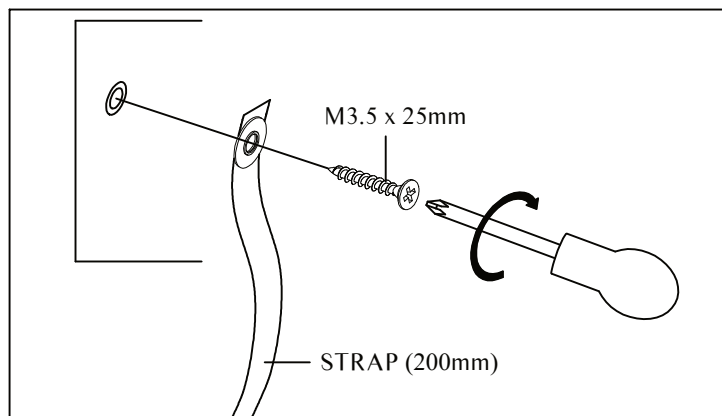

NOTE: Wall fixings are not supplied with this product as different wall materials require different types of fixing devices (such as Rawl plugs on bricks wall). You must use fixing devices suitable for the type of wall you intend to mount this product to. Please ensure that the head of any screw used has a diameter greater than the diameter of the mounting hole on the product and that the fixing is safe and secure before use.

The straps and screws which to fix the strap on to the furniture are provided only.

HARDWARE LIST



STRAP (200mm) - 1 Pc

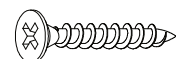

M3.5 x 25mm - 1 Pc

MAXIMUM LOADS CHARGES MAXIMALES / CARGA MAXIMA

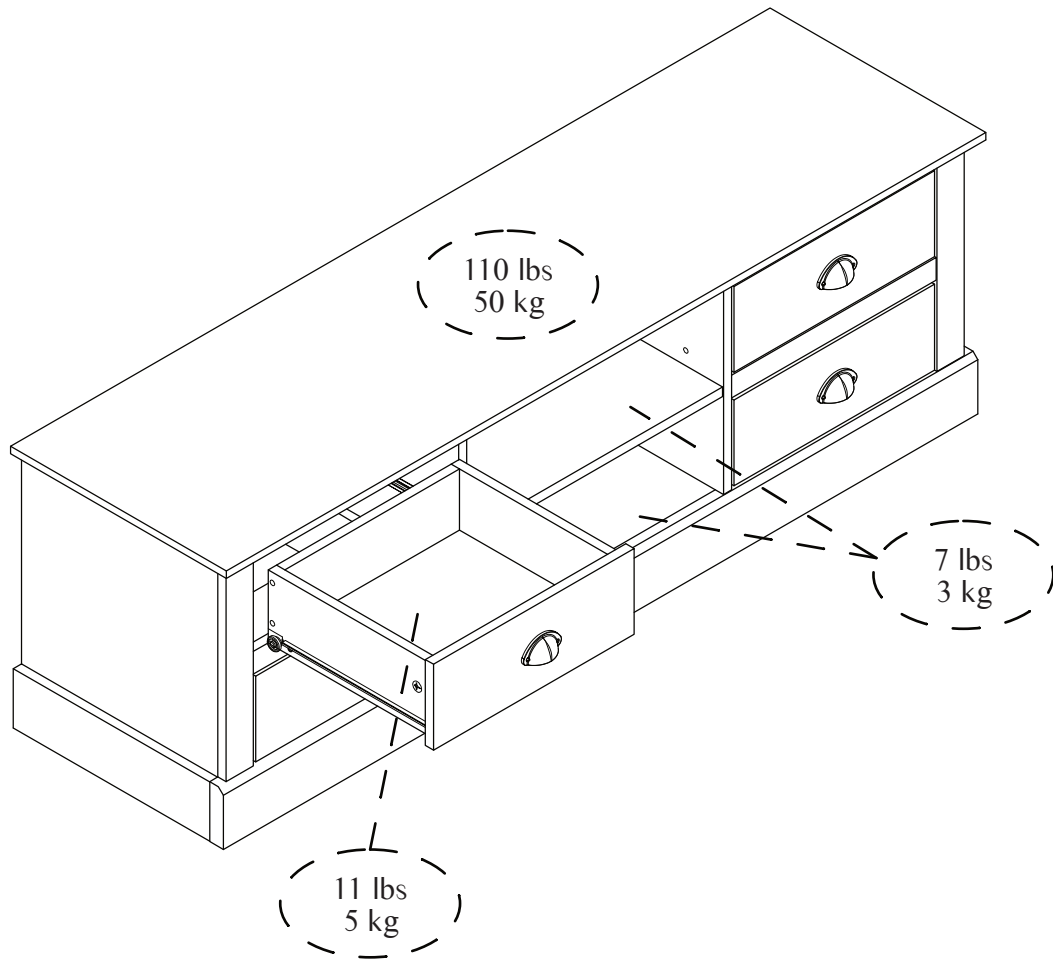

This unit has been designed to support the maximum loads shown. Exceeding these load limits could cause sagging, instability, product collapse, and/or serious injury.

Ce meuble a été conçu pour supporter les charges maximales indiquées. En excédant ces limites de charge, le meuble pourrait devenir instable, s'effondrer, et/ou causer des blessures graves.

Esta unidad ha sido diseñada para soportar la carga máxima anotada. El exceder estos límites puede causar inestabilidad, colapsarse y/o causar serias lesiones.
