

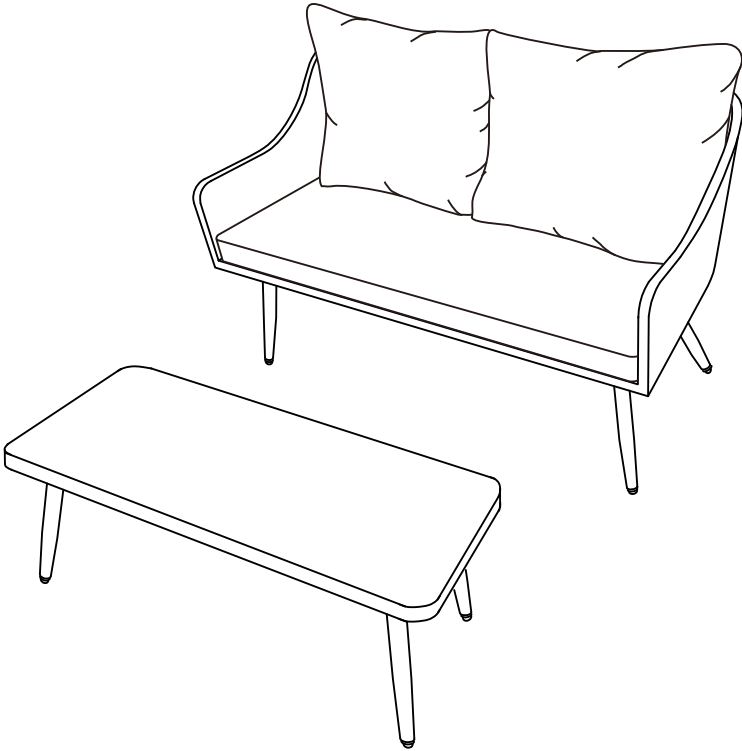

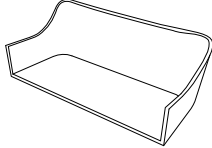

Outdoor Wicker Loveseat & Coffee Table

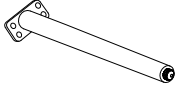
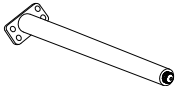
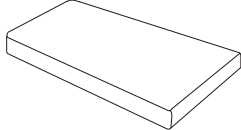
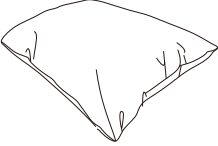
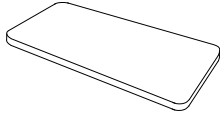
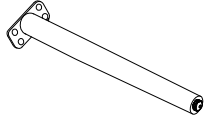

PART LIST

A 	B 	C 	D 	E 
Seat Panel 1 PC	Front Leg 2 PCS	Back Leg 2 PCS	Seat Cushion 1 PC	Back Cushion 2 PCS
F 	G 			
Table Panel 1 PC	Table Leg 4 PCS			

HARDWARE LIST

#1 	#2 	#3 
M6*15mm Bolt 32 PCS (Extra 1)	M6mm Flat Washer 32 PCS (Extra 1)	M6mm Allen Wrench 1 PC

Step 1. Lay seat panel (part A) upside down on a soft flat surface, such as carpet, as shown below. Attach front legs (part B) and back legs (part C) to seat panel (part A) using bolts (part #1), flat washers (part #2) and allen wrench (part #3).

NOTE: Please fully tighten all bolts at this time.

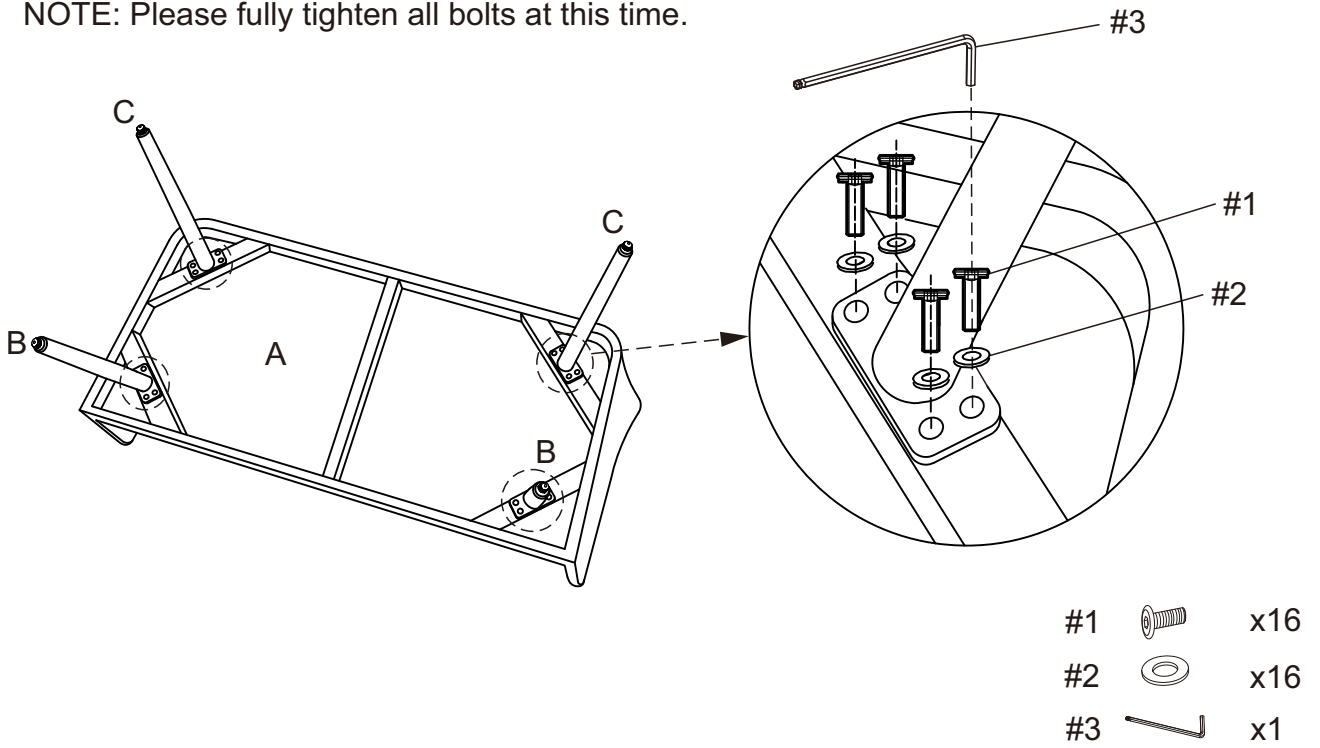



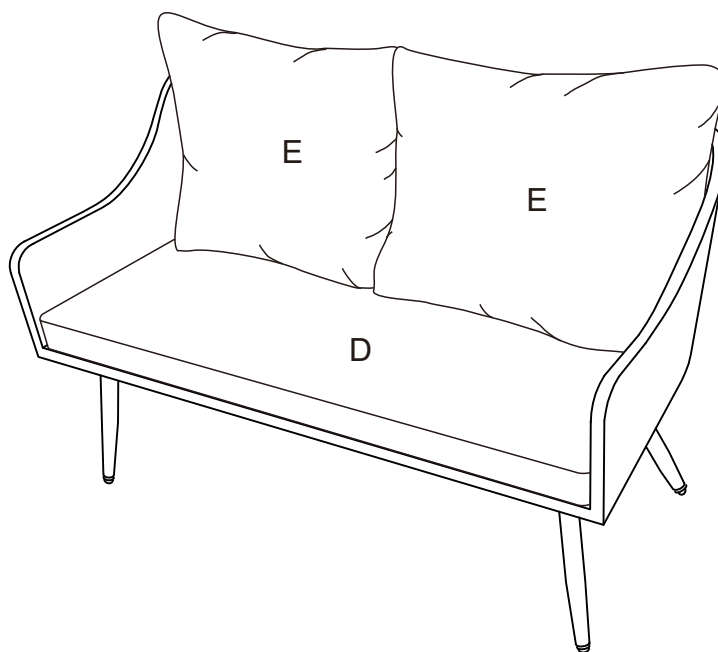

Step 2. Carefully turn unit upright. Add seat cushion (part D) and back cushions (part E) as shown below.

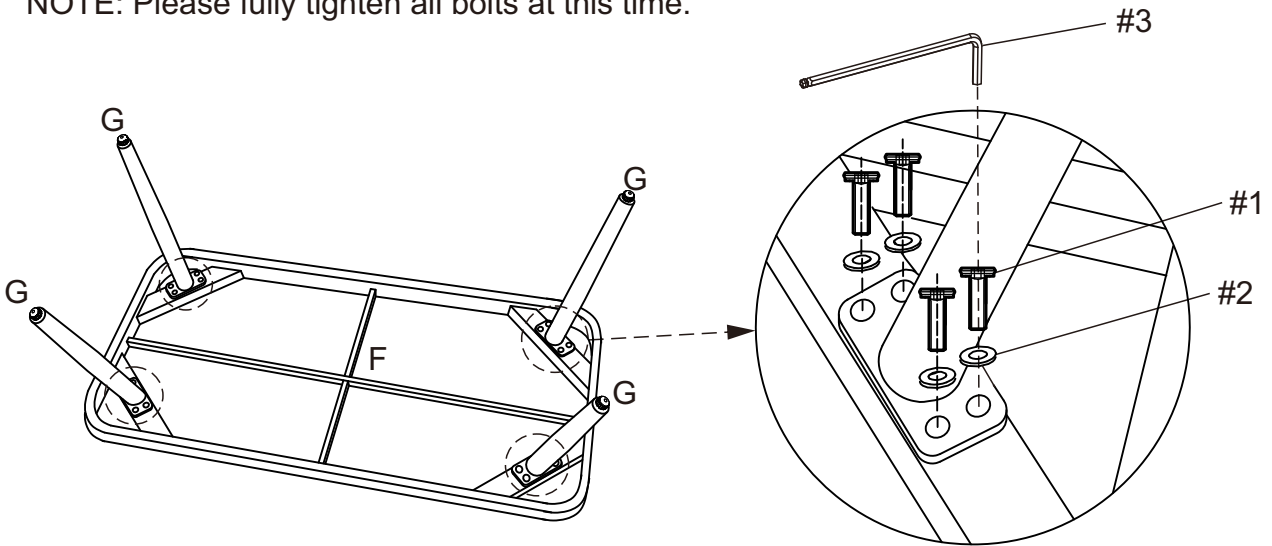

Step 3. Lay table panel (part F) upside down on a soft flat surface, such as carpet, as shown below. Attach table legs (part G) to table panel (part F) using bolts (part #1), flat washers (part #2) and allen wrench (part #3).

NOTE: Please fully tighten all bolts at this time.



- | | | |
|----|---|-----|
| #1 |  | x16 |
| #2 |  | x16 |
| #3 |  | x1 |

Step 4. Carefully turn assembled unit upright as shown below.

