

User Manual

Manual del usuario

Manuel d'utilisateur



877-472-4296

www.medalsports.com

LIMITED 90 DAYS WARRANTY

This product is covered by a limited warranty that is effective for 90 days from the date of purchase. If, during the limited warranty period, a part is found to be defective or breaks, we will offer replacement parts at no cost to you, the customer. The only exceptions to the warranty include mainframes, table tops, playing surfaces, batteries or tools.

The above warranty will not apply in cases of damages due to improper usage, alteration, misuse, abuse, accidental damage or neglect.

This Limited Warranty gives you specific legal rights and you may also have other rights vary from one State (province) to another.

A PURCHASE RECEIPT (or other proof of purchase) will be required before any warranty service is initiated. For all requests for warranty service, please feel free to contact our Consumer Service Department.

Please be aware of your product's Limited Warranty for the return/refund policy from the store. We, at Medal Sports, cannot handle the product which is out of product's limited warranty since we only provide available parts. Thank you!

PLEASE CONTACT US BEFORE RETURNING THE PRODUCT TO THE STORE!

GARANTÍA LIMITADA DE 90 DÍAS

Este producto está cubierto por una garantía limitada que tiene una vigencia de 90 días a partir de la fecha de su compra. Durante el período de la garantía limitada, si una parte defectuosa o quebrada es encontrada, nosotros ofreceremos una reparación o un reemplazo de la partes sin ningún costo para usted, nuestro cliente. Las únicas excepciones de la garantía incluyen unidades centrales, tableros de mesa, superficies de juego, pilas o herramientas.

La susodicha garantía no se aplicará en los casos de daños debido al uso impropio, la alteración, el mal uso, el abuso, el daño accidental o la negligencia.

Esta garantía limitada le da a usted derechos legales específicos, usted también puede tener otros derechos que varían de un estado (provincia) a otro.

EL RECIBO DE LA COMPRA (U otra prueba de compra) sería requerida antes que cualquier servicio de garantía fuera iniciada. Para todo pedido por servicio de garantía, por favor siéntase libre de ponerse en contacto con nuestro Departamento de Servicio de Consumidor.

Por favor tenga en cuenta sobre la Garantía Limitada de su producto para la política de vuelta/reembolso desde la tienda. Nosotros, Medal Sports, no podemos manejar el producto que está fuera del límite de garantía ya que proporcionamos solamente partes disponibles. ¡Gracias!

¡POR FAVOR PÓNGASE EN CONTACTO CON NOSOTROS ANTES DE DEVOLVER EL PRODUCTO A LA TIENDA!

GARANTIE LIMITEE DE 90 JOURS

Ce produit est couvert par une garantie limitée valable 90 jours à compter de la date d'achat. Si pendant cette période une pièce est jugée défectueuse ou se casse, nous la remplacerons gratuitement. Les seules exceptions à la garantie comprennent les armatures principales, les dessus de table, les surfaces de jeu, les piles ou les outils.

La garantie ci-dessus ne s'applique pas en cas de dommages occasionnés par une mauvaise utilisation, une altération, un abus, des un dommage accidentel ou une négligence.

Cette garantie limitée vous accorde des droits légaux spécifiques ainsi que d'autres droits variant d'un état (province) à un autre.

UNE FACTURE D'ACHAT (ou toute autre preuve d'achat) sera exigée avant toute intervention sous garantie. Pour toute demande d'intervention sous garantie, veuillez contacter notre Service Clientèle.

Comprenez votre garantie limitée de produit en ce qui concerne notre politique de retour/remboursement depuis le magasin. Chez Medal Sports, nous ne pouvons pas traiter un produit qui n'est plus sous garantie puisque nous ne pouvons que fournir les pièces disponibles. Remerciements!

VEUILLEZ NOUS CONTACTER AVANT DE RETOURNER LE PRODUIT AU MAGASIN!



WE ARE READY TO HELP

DO NOT RETURN TO STORE

ESTAMOS LISTOS AYUDA

NO DEVOLVERLO A LA TIENDA

NOUS SOMMES PRÊTS À VOUS AIDER

NE PAS RAPPORTER EN MAGASIN

Please Contact | Por favor Contactar | Veuillez contacter

MD SPORTS

Customer Service
Toll Free

Servicio al Cliente
Llamada Gratuita

Service Clientèle
Appel Gratuit

877-472-4296

Mon.-Fri.,
9:00 a.m. to 5:00 p.m. EST

Lunes a Viernes,
9:00 a.m. a 5:00 p.m. ET

Du lundi au vendredi de
9:00 a 17 heures HNE

For additional resources and
Frequently Asked Questions,
please visit us at

Por mayor información y
Preguntas Frecuentes, favor
visitarnos en

Pour toute information
complémentaire ou réponse
aux questions fréquentes,
veuillez vous rendre sur

www.medalsports.com

TOOLS REQUIRED

Phillips Screwdriver - **Not Included**
Wrench - **Included**

 **RECOMMENDED**

Electric Screwdrivers may be helpful during assembly; however, please set a low torque and use extreme caution.



Power Tools: **Set to Low Torque**
Herramientas eléctricas: **Establecer a baja velocidad**
Visseuse électrique: **Couple faible**

HERRAMIENTAS NECESARIAS

Destornillador Phillips - **No incluido**
Llave Inglesa - **Incluido**

 **RECOMENDADO**

Los destornilladores eléctricos pueden ser de gran ayuda durante el ensamblado; sin embargo, por favor ajuste el par de giro bajo y sea extremadamente precavido.



High Torque Over Tightened
Una alta velocidad puede apretar demasiado
Un couple élevé peut créer des dommages

OUTILS REQUIS

Tournevis cruciforme - **Non inclus**
Clé anglaise - **Incluse**

 **RECOMMANDÉ**

Un tournevis électrique peut être utile pour l'assemblage; utilisez cependant une vitesse de rotation lente et avec prudence.

 **IMPORTANT NOTICE**

1. Please do not sit, climb or lean on the product.
2. Please do not drag the product when moving it in order to avoid damaging the legs.
3. This is not a children's toy.
4. Assembly required.
5. DO NOT over tighten bolts and screws.

 **AVISO IMPORTANTE**

1. Por favor no se siente, suba o incline sobre el producto.
2. Por favor no arrastre el producto cuando lo mueva de lugar para evitar daño en las patas de la mesa.
3. Este no es un juguete para niños.
4. Se requiere ensamblaje.
5. NO apriete en exceso los tornillos y los pernos.

 **NOTE IMPORTANTE**

1. Veuillez ne pas vous asseoir, grimper ou vous appuyer sur la produit.
2. Veuillez ne pas déplacer la produit en la tirant pour ne pas endommager les pieds.
3. Ce n'est pas un jeu d'enfant.
4. Assemblage requis.
5. NE PAS serrer excessivement les boulons et les vis.



At least 4 adults needed
Se necesitan al menos 4 adultos
Il faut au moins 4 adultes



No children in assembly area
No deben estar los niños en el area de ensamble
Pas d'enfants dans la zone d'assemblage



Keep away from pets in assembly area
Mantener alejados a los animales domesticos del area de ensamble
Tenir les animaux de compagnie à distance



Do not use or keep product outdoors. For indoor use only. No wet/humid conditions.
No usar o guardar el producto en el exterior. Solo para uso en interior. No utilizar ni guardar el producto en lugares húmedos o mojados.

N'utilisez ni ne stockez ce produit en extérieur.
Uniquement pour utilisation en intérieur.
Ne pas exposer à l'humidité.

CARE INSTRUCTIONS

- To prolong the life of your game, clean your game regularly. Please only use furniture polish spray to clean the exterior surfaces of the product. This will remove dirt, sweat, and other debris that can build up over time and damage the materials.

INSTRUCCIONES DE CUIDADO

- Para prolongar la vida útil de tu juego, límpialo regularmente. Por favor use solamente spray de pulido para muebles para limpiar la superficie exterior del producto. Esto eliminará la suciedad, el sudor y otros desechos que pueden acumularse con el tiempo y dañar los materiales.











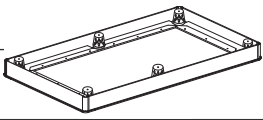
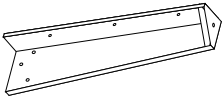
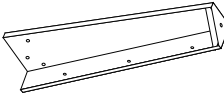

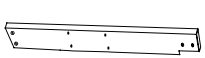
INSTRUCTIONS D'ENTRETIEN

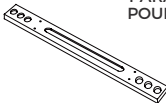
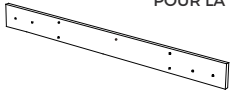
- Pour prolonger la durée de vie de votre jeu, nettoyez-le régulièrement. Veuillez utiliser seulement le vernis pour meuble pour nettoyer les surfaces extérieures du produit de jeu. Cela permettra d'éliminer la saleté, la sueur et les autres débris qui peuvent s'accumuler avec le temps et endommager les matériaux.

PARTS IDENTIFIER

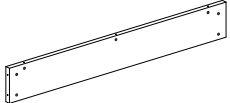
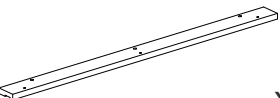
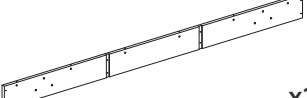
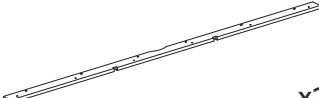
IDENTIFICADOR DE PIEZAS

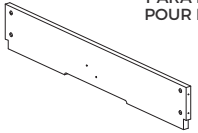



IDENTIFICATEUR DE PIÈCES

PART NUMBER NÚMERO DE PIEZA NUMÉRO D'ARTICLE			1			FOR FIG. 4 PARA LA FIG. 4 POUR LA FIG. 4			FIG. NUMBER NÚMERO DE FIG. NUMÉRO FIG.		
PART PIEZA PIÈCE						x1			QUANTITY CANTIDAD QUANTITÉ		
PART NAME			Mainframe			Unidad principal			Unité centrale		
2			3			4			5		
FOR FIG. 5 PARA LA FIG. 5 POUR LA FIG. 5			FOR FIG. 5 PARA LA FIG. 5 POUR LA FIG. 5			FOR FIG. 6 PARA LA FIG. 6 POUR LA FIG. 6			FOR FIG. 7 PARA LA FIG. 7 POUR LA FIG. 7		
											
x2			x2			x2			x4		
Right Leg	Pata derecha	Pied droit	Left Leg	Pata izquierda	Pied gauche	End Leg Panel	Panel de extremo para pata	Panneau inférieur du pied	Leg Leveler	Nivelador de pata	Niveleur de pied
6			7			8			9		
FOR FIG. 9 PARA LA FIG. 9 POUR LA FIG. 9			FOR FIG. 9 PARA LA FIG. 9 POUR LA FIG. 9			FOR FIG. 10 PARA LA FIG. 10 POUR LA FIG. 10			FOR FIG. 10 PARA LA FIG. 10 POUR LA FIG. 10		
											
x2			x2			x1			x1		
Cue Rack - Side Panel	Estante de tacos - Panel lateral	Support de queue de billard - panneau latéral	Cue Rack - Middle Shelf	Estante de tacos - Repisa de en medio	Support de queue de billard - tablette du milieu	Cue Rack - Base Panel	Estante de tacos - Panel de base	Support de queue de billard - panneau inférieur	Cue Rack - Top Panel	Pata plástica - C	Pied en plastique - C
10			11			12			13		
FOR FIG. 11 PARA LA FIG. 11 POUR LA FIG. 11			FOR FIG. 11 PARA LA FIG. 11 POUR LA FIG. 11			FOR FIG. 11 PARA LA FIG. 11 POUR LA FIG. 11			FOR FIG. 1 PARA LA FIG. 1 POUR LA FIG. 1		
											
x2			x2			x1			x2		
Cue Rack Hook	Gancho del estante de tacos	Pied en plastique - D	Cue Holder	Sujetador de tacos	Attache - queues	Hook	Gancho	Crochet	Lower End Apron	Delantal final inferior	Tablier d'extrémité inférieur
14			15			16			17		
FOR FIG. 1 PARA LA FIG. 1 POUR LA FIG. 1			FOR FIG. 1 PARA LA FIG. 1 POUR LA FIG. 1			FOR FIG. 1 PARA LA FIG. 1 POUR LA FIG. 1			FOR FIG. 3 PARA LA FIG. 3 POUR LA FIG. 3		
											
x2			x2			x2			x2		
End Top Board	Tablero superior final	Panneau supérieur final	Lower Side Apron	Delantal lateral inferior	Tablier latéral inférieur	Side Top Board	Tablero superior lateral	Panneau supérieur latéral	Adjustable Bracket	Corchete regulable	Support réglable
18			19								
FOR FIG. 3 PARA LA FIG. 3 POUR LA FIG. 3			FOR FIG. 1 PARA LA FIG. 1 POUR LA FIG. 1								
											
x2			x1								
Support Board	Tablero de soporte	Plateau de support	Glue	Pegamento	Colle						

ACCESSORIES

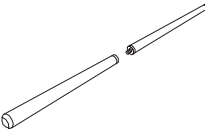
ACCESORIOS

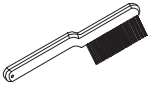
ACCESSOIRES

20			21			22			23		
											
x2			x1			x1			x2		
Cue	Taco	Queue de billard	Triangle	Triángulo	Triangle	Brush	Cepillo	Brosse	Chalk	Tiza	Craie

ACCESSORIES

ACCESORIOS



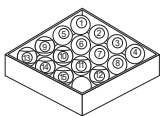







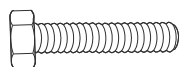

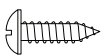

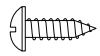
ACCESSOIRES

		
x1		
Billiard Ball Set	Bola de billar	Ensemble boules de billard

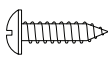
HARDWARE

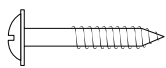
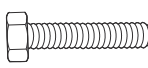
HARDWARE

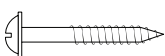





MÉTAUX

A1  x12 FOR FIG. 5 PARA LA FIG. 5 POUR LA FIG. 5 M8x38mm Bolt Perno M8x38mm Boulon M8x38mm	A2  x12 FOR FIG. 5 PARA LA FIG. 5 POUR LA FIG. 5 M8 Washer Arandela M8 Rondelle M8	A3  x12 FOR FIG. 6 PARA LA FIG. 6 POUR LA FIG. 6 T4x15mm Screw Tornillo T4x15mm Vis T4x15mm	A4  x4 FOR FIG. 11 PARA LA FIG. 11 POUR LA FIG. 11 3x16mm Bolt Perno 3x16mm Boulon 3x16mm
A5  x5 FOR FIG. 11 PARA LA FIG. 11 POUR LA FIG. 11 T4x12mm Screw Tornillo T4x12mm Vis T4x12mm	A6  x12 FOR FIG. 5 PARA LA FIG. 5 POUR LA FIG. 5 M8 Spring Lock Washer Arandela de seguridad M8 Rondelle de blocage M8	A7  x26 FOR FIG. 1, 10 PARA LA FIG. 1, 10 POUR LA FIG. 1, 10 4x45mm Flat Head Screw Tornillo de cabeza plana 4x45mm Vis tête plate 4x45mm	A8  x8 FOR FIG. 9 PARA LA FIG. 9 POUR LA FIG. 9 4x38mm Screw Tornillo 4x38mm Vis 4x38mm
A9  x4 FOR FIG. 4 PARA LA FIG. 4 POUR LA FIG. 4 4x18mm Screw Tornillo 4x18mm Vis 4x18mm	A10  x4 FOR FIG. 3 PARA LA FIG. 3 POUR LA FIG. 3 M5x25mm Bolt Perno M5x25mm Boulon M5x25mm	A11  x16 FOR FIG. 2, 3 PARA LA FIG. 2, 3 POUR LA FIG. 2, 3 4x45mm Screw Tornillo 4x45mm Vis 4x45mm	A12  x18 FOR FIG. 4 PARA LA FIG. 4 POUR LA FIG. 4 M6x22mm Bolt Perno M6x22mm Boulon M6x22mm
A13  x18 FOR FIG. 4 PARA LA FIG. 4 POUR LA FIG. 4 M6 Washer Arandela M6 Rondelle M6	A14  x2 FOR FIG. 11 PARA LA FIG. 11 POUR LA FIG. 11 4x32mm Screw Tornillo 4x32mm Vis 4x32mm	A15  x1 Wrench Llave inglesa Clé anglaise	

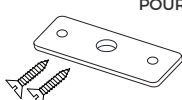
PRE-INSTALLED PARTS

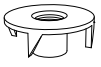
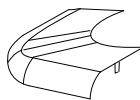
PIEZAS PREINSTALADAS

PIÈCES PRÉINSTALLÉES

P1  x4 FOR FIG. 5 PARA LA FIG. 5 POUR LA FIG. 5 Square Nut with Screws Tuerca cuadrada con tornillos Écrou carré avec vis	P2  x4 FOR FIG. 4 PARA LA FIG. 4 POUR LA FIG. 4 Apron Corner Cubierta de esquina Tablier de coin	P3  x12 FOR FIG. 5 PARA LA FIG. 5 POUR LA FIG. 5 M8 T - Nut Tuerca - T M8 Écrou en T M8	P4  x4 FOR FIG. 8 PARA LA FIG. 8 POUR LA FIG. 8 Top Corner Esquina superior Coin supérieur
P5  x4 FOR FIG. 8 PARA LA FIG. 8 POUR LA FIG. 8 Corner Pocket Cap Gorra de bolsillo de esquina Capuchon poche de coin	P6  x2 FOR FIG. 8 PARA LA FIG. 8 POUR LA FIG. 8 Side Pocket Cap Gorra de bolsillo lateral Capuchon poche latérale	P7  x6 FOR FIG. 4 PARA LA FIG. 4 POUR LA FIG. 4 Fabric Pocket Bolsillo de tela Poche en tissu	P8  x4 FOR FIG. 3 PARA LA FIG. 3 POUR LA FIG. 3 M5 T - Nut Tuerca - T M5 Écrou en T M5

BEFORE ASSEMBLY

1. Find a clean, level place to begin the assembly of your product.
2. Verify that you have all listed parts as shown on the part list pages. If any parts are missing, call our customer service.

ANTES DE MONTAR

1. Encuentre un lugar limpio y nivelado para comenzar el ensamblaje del producto.
2. Compruebe que tenga todas las piezas que se muestran en la lista de piezas. Si falta alguna pieza, llame a nuestro servicio al cliente.

AVANT L'ASSEMBLAGE

1. Trouvez un endroit propre et plat pour commencer à assembler votre produit.
2. Vérifiez que vous avez toutes les pièces énumérées comme indiqué sur les pages de liste des pièces. S'il y a des pièces qui manquent, appelez notre service à la clientèle.

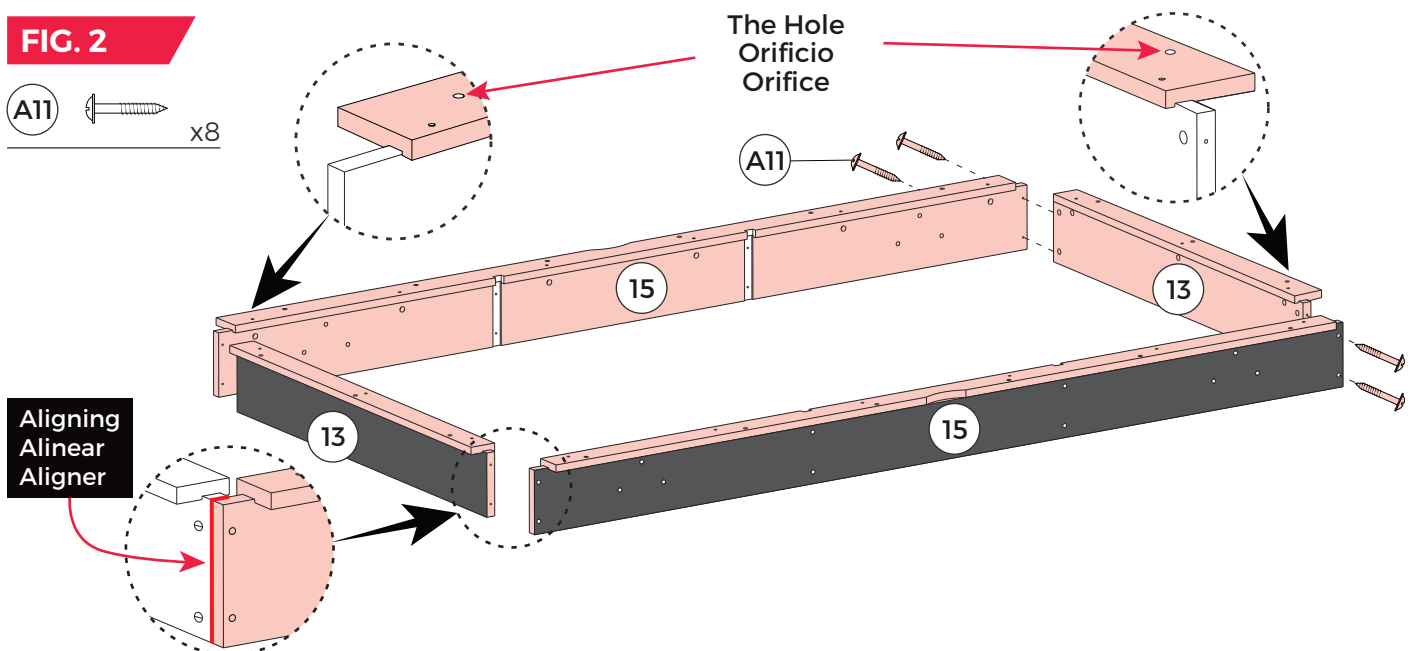
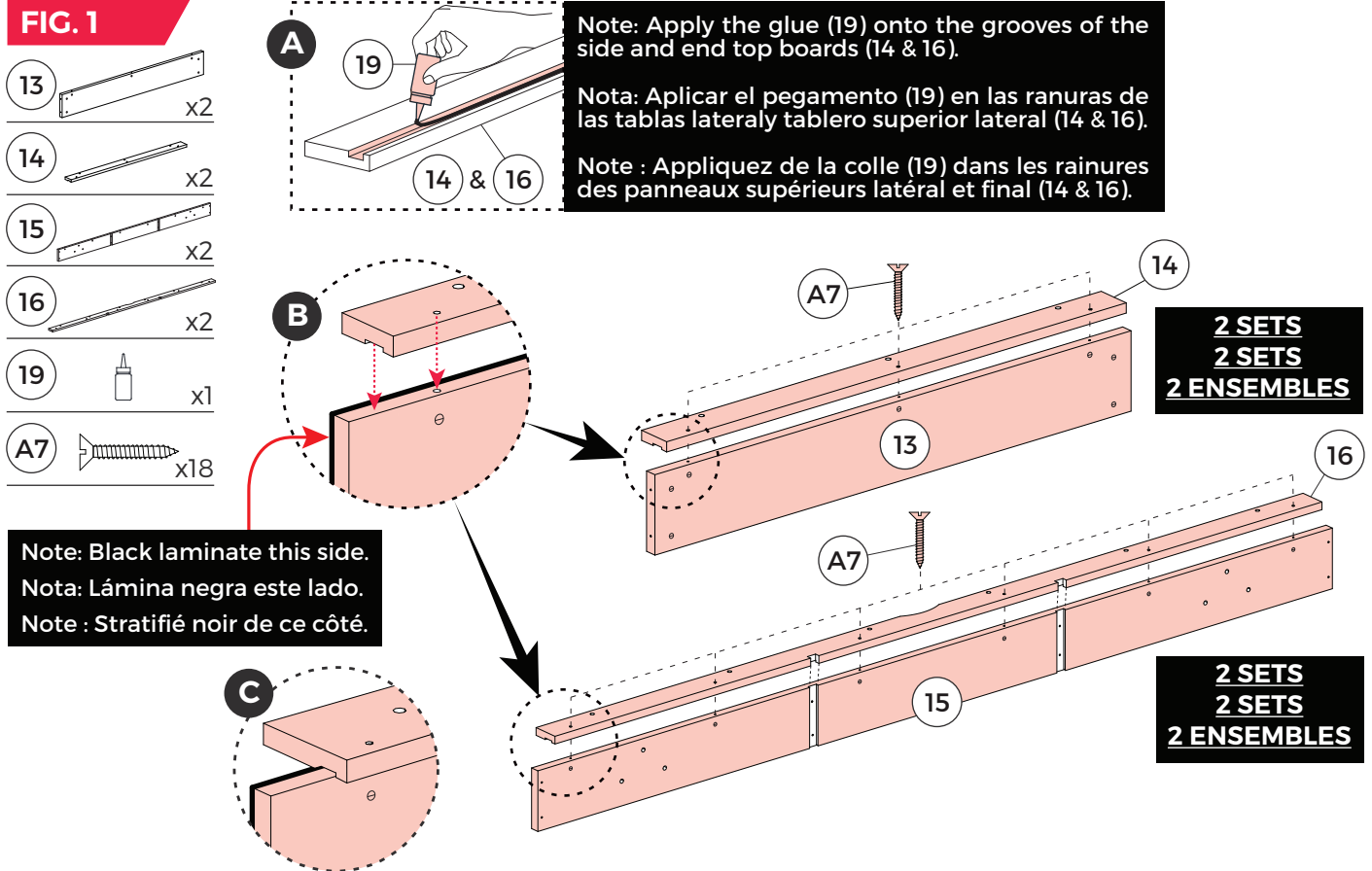
ASSEMBLY**MONTAJE****ASSEMBLAGE**

ASSEMBLY

MONTAJE

ASSEMBLAGE

FIG. 3

2 SETS
2 SETS
2 ENSEMBLES

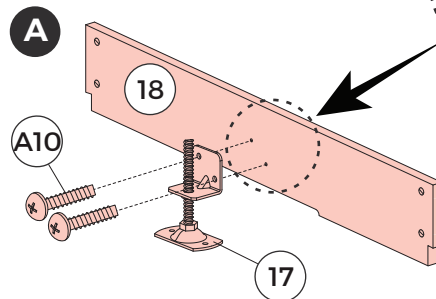
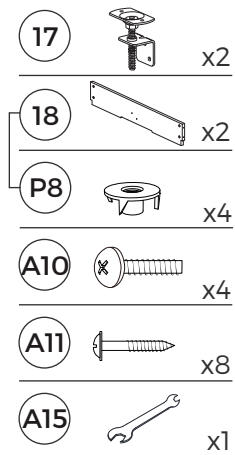

Note: P8 on the back.
Nota: P8 está en la parte trasera en la espalda.
Note : P8 au dos.

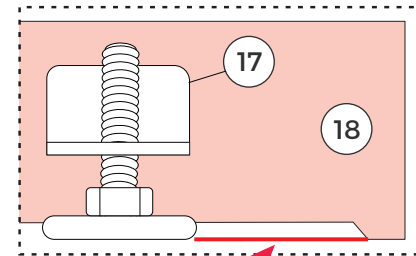
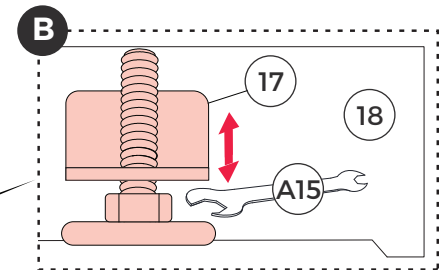

Aligning
Alinear
Aligner

Note: Please note that adjustable bracket (17) and support boards (18) must be parallel with each other.

Nota: Favor notar que los corchete regulable (17) y las tablero de soporte (18) deben venire en paralelo.

Note : Veuillez noter que les support réglable (17) et les plateaux de support (18) doivent être parallèles.

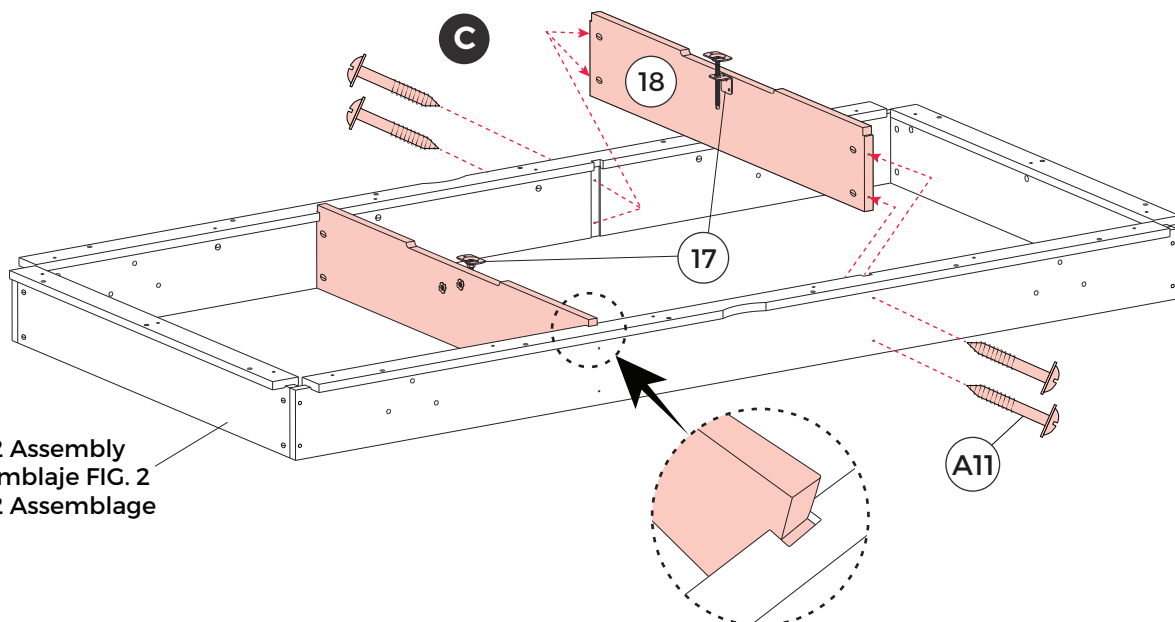

FIG. 2 Assembly
Ensamblaje FIG. 2
FIG. 2 Assemblage

ASSEMBLY

MONTAJE

ASSEMBLAGE

FIG. 4

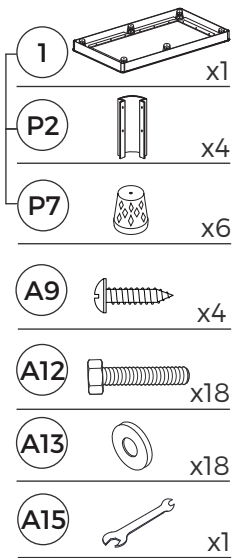
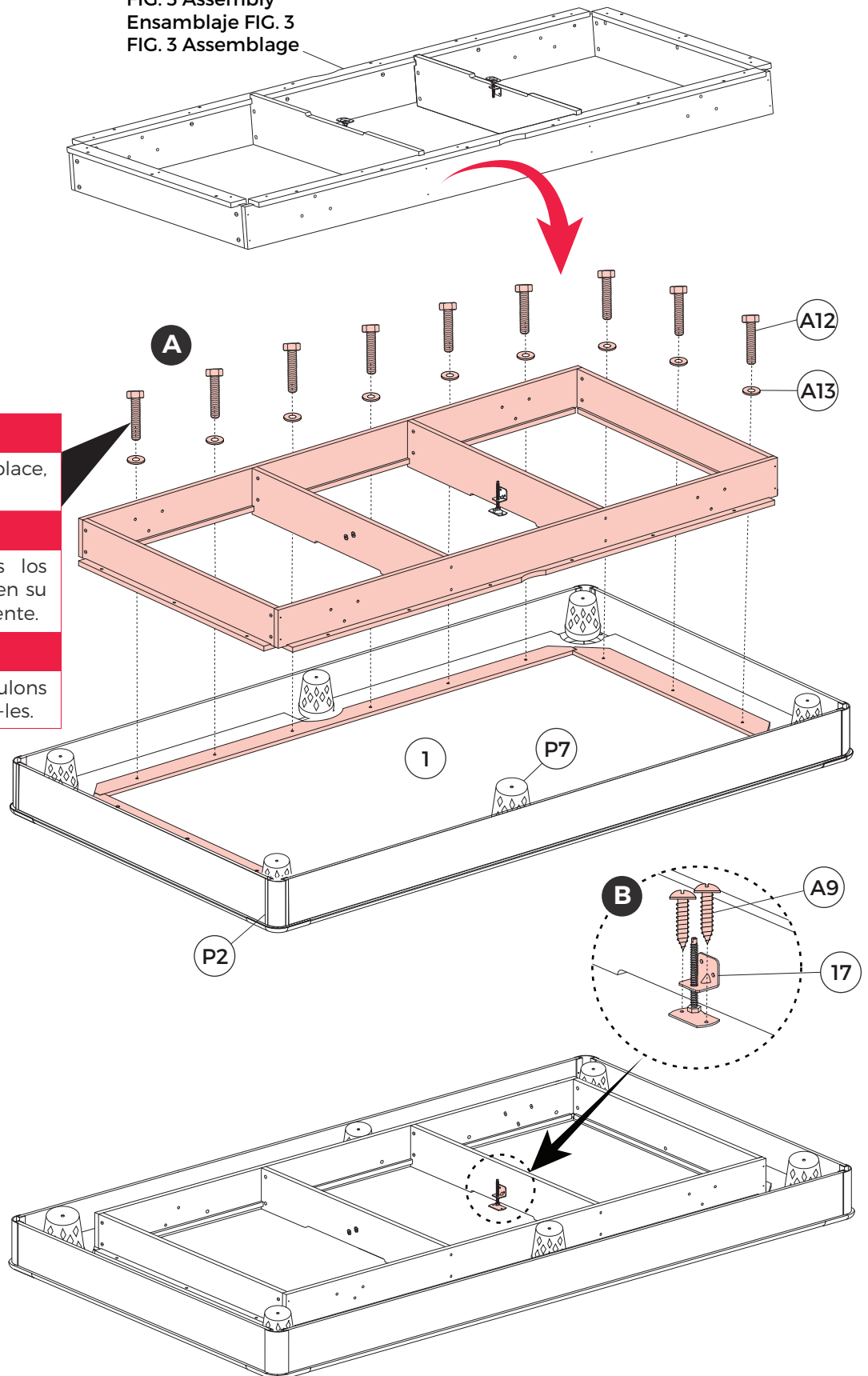
 FIG. 3 Assembly
 Ensamblaje FIG. 3
 FIG. 3 Assemblage

TIP

Once all the Bolts are in place, tighten them.

CONSEJO

Después de que todos los pernos estén insertados en su lugar, apriételes nuevamente.

CONSEIL

Attendez que tous les boulons soient insérés, puis serrez-les.

ASSEMBLY

MONTAJE

ASSEMBLAGE

FIG. 5

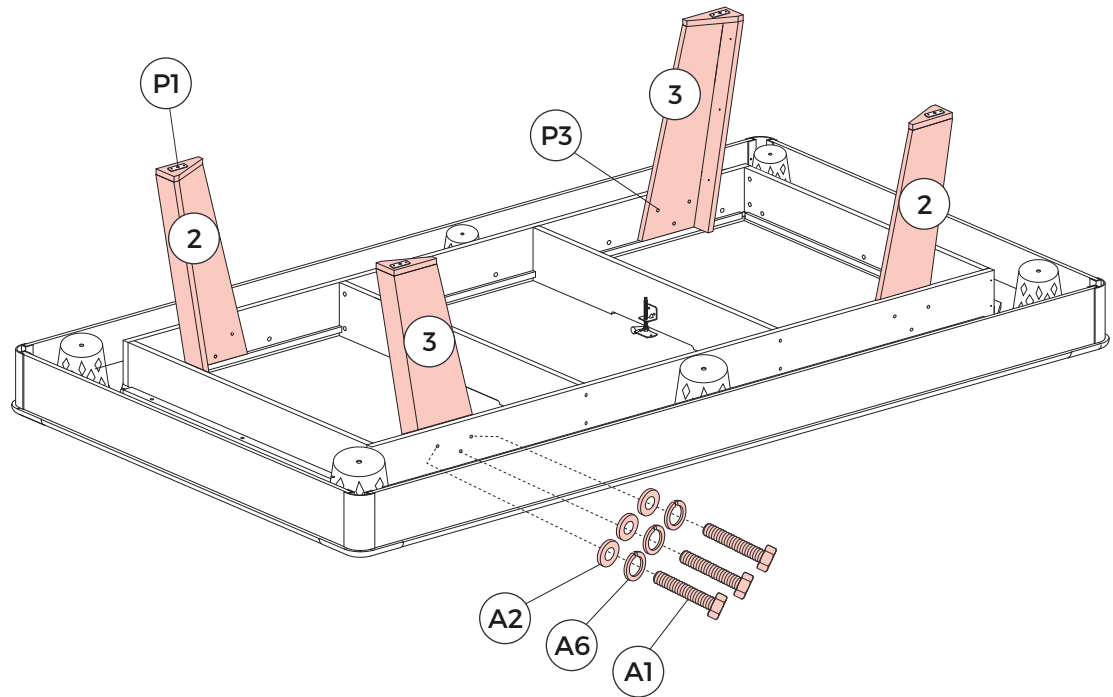
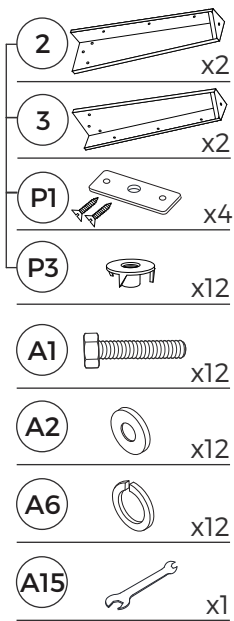
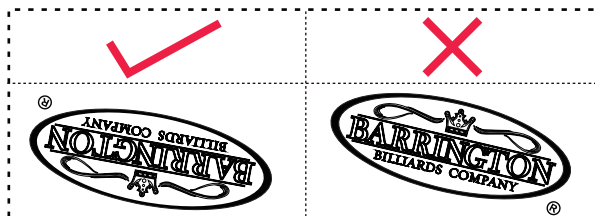
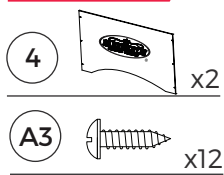

FIG. 6



Note: Both logo panels should be inverted when assembling.

Nota: Ambos paneles del logo deben estar invertidos al ensamblar.

Note : Les deux panneaux logo doivent être inversés pendant l'assemblage.

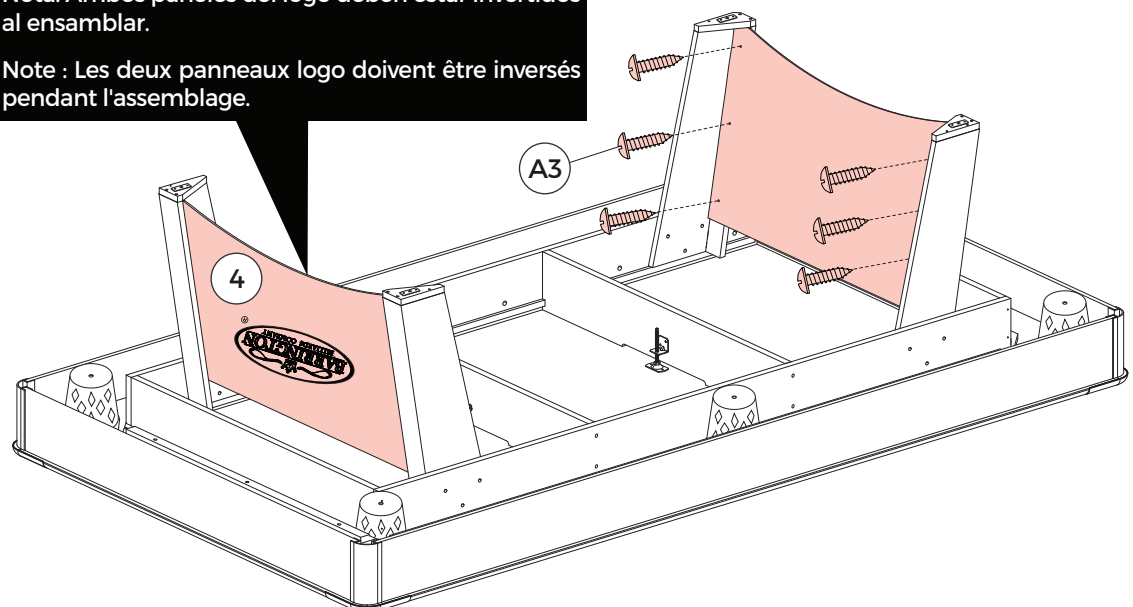

ASSEMBLY

MONTAJE

ASSEMBLAGE

FIG. 7

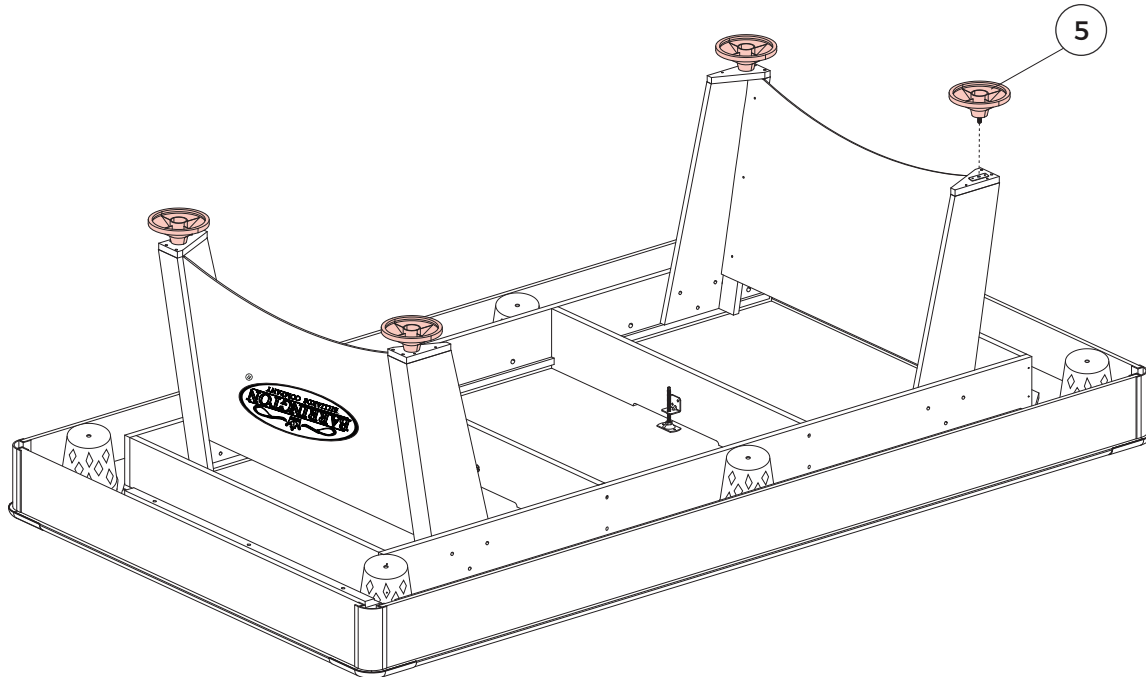
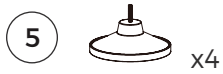

Note: Go back and make sure that all connections are tight.

Nota: Vuelva y asegúrese que todas las conexiones están apretadas.

Note : Revérifiez que toutes les connexions sont bien serrées.

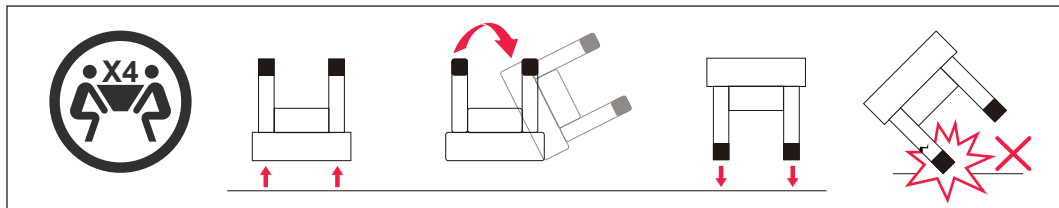
⚠ CAUTION

1. Lift the table off the ground.
2. Turn the table over.
3. Place it on all feet at the same time on the ground.

⚠ PRECAUCIÓN

1. Levante la mesa del suelo.
2. Voltee la mesa.
3. Coloque las patas de la mesa sobre el piso al mismo tiempo.

⚠ ATTENTION

1. Soulevez la table du sol.
2. Retournez-la.
3. Placez ses pieds sur le sol simultanément.

ASSEMBLY

MONTAJE

ASSEMBLAGE

FIG. 8

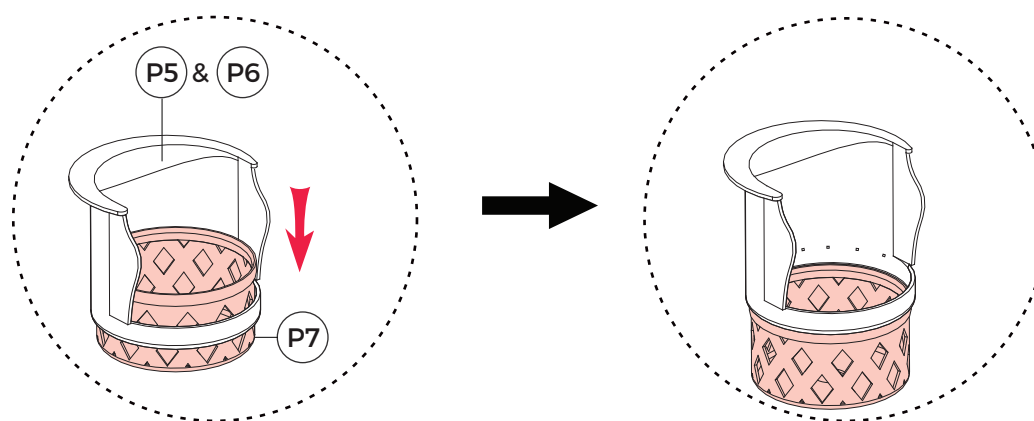
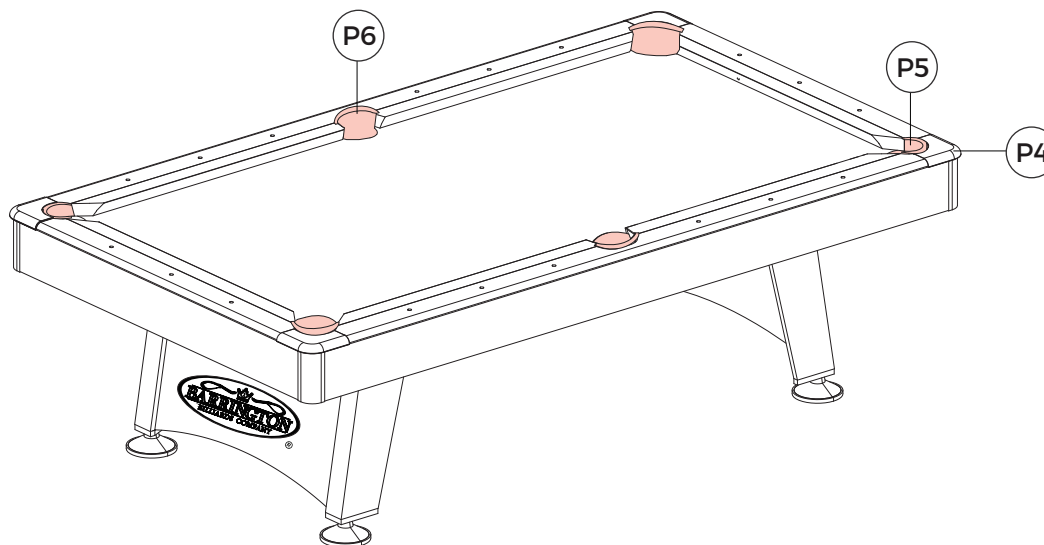
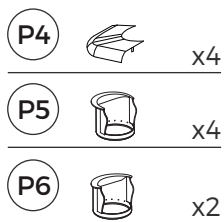

SIDE VIEW / VISTA LATERAL / VUE LATÉRALE

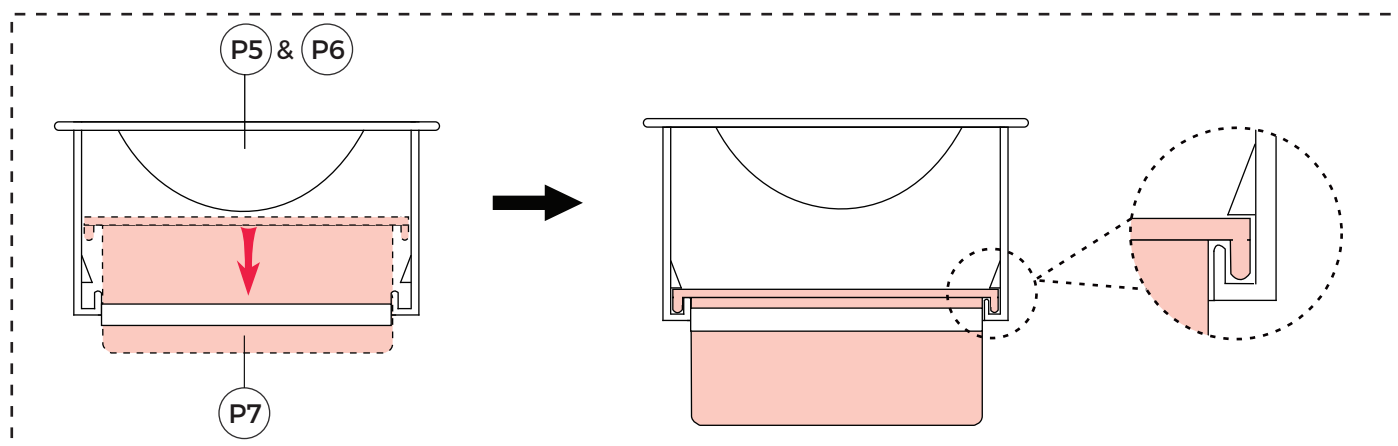

Note: DO NOT lift the table by the pockets. If you move the table, do not lift it by placing your hands beneath the pockets and do not lean or put pressure on them. Do not lean or sit on the end or side rails as this may damage the table.

Nota: No levante la mesa por las troneras. Si mueva la mesa, no la levante por colocación de sus manos bajo las troneras y tampoco apoyarse o haga presión sobre ellos. No inclinarse o sentarse sobre el final o el lado de rieles, esto puede dañar la mesa.

Note : NE soulevez PAS la table par les poches. Si vous déplacez la table, ne la soulevez pas en plaçant vos mains sous les poches et ne vous penchez pas ni ne vous appuyez sur celles-ci. Ne vous penchez pas ni ne vous asseyez sur l'extrémité ou les rails latéraux pour éviter d'endommager la table.

STEP 1
PASO 1
ÉTAPE 1

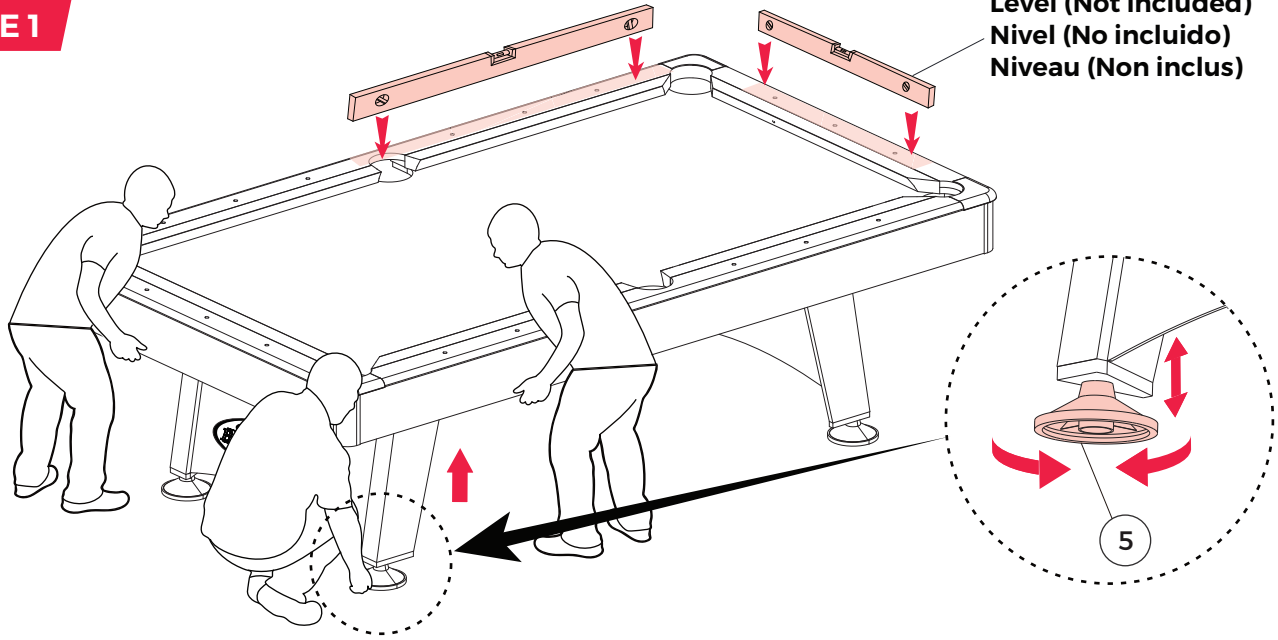

STEP 2
PASO 2
ÉTAPE 2

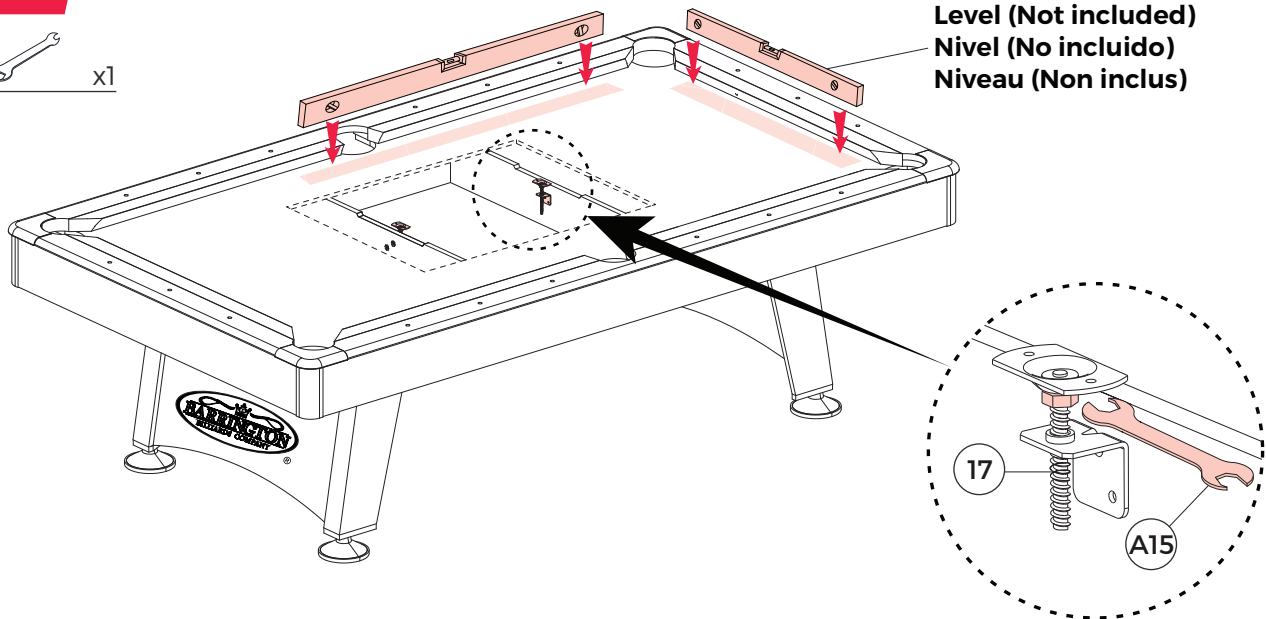

ADJUST CONCAVE TABLE
AJUSTAR LA MESA CÓNCAVA
POUR AJUSTER LA TABLE CONCAVE

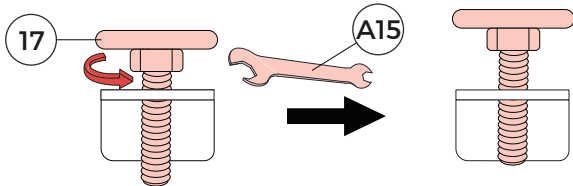

ADJUST CONVEX TABLE
AJUSTAR LA MESA CONVEXA
POUR AJUSTER LA TABLE CONVEXE

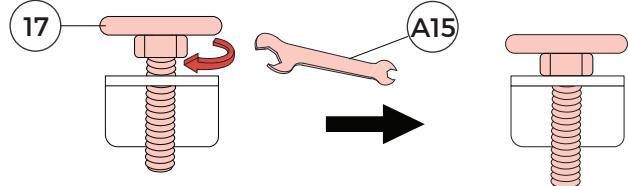

FIG. 9

- 6 x2
- 7 x2
- A8 x8

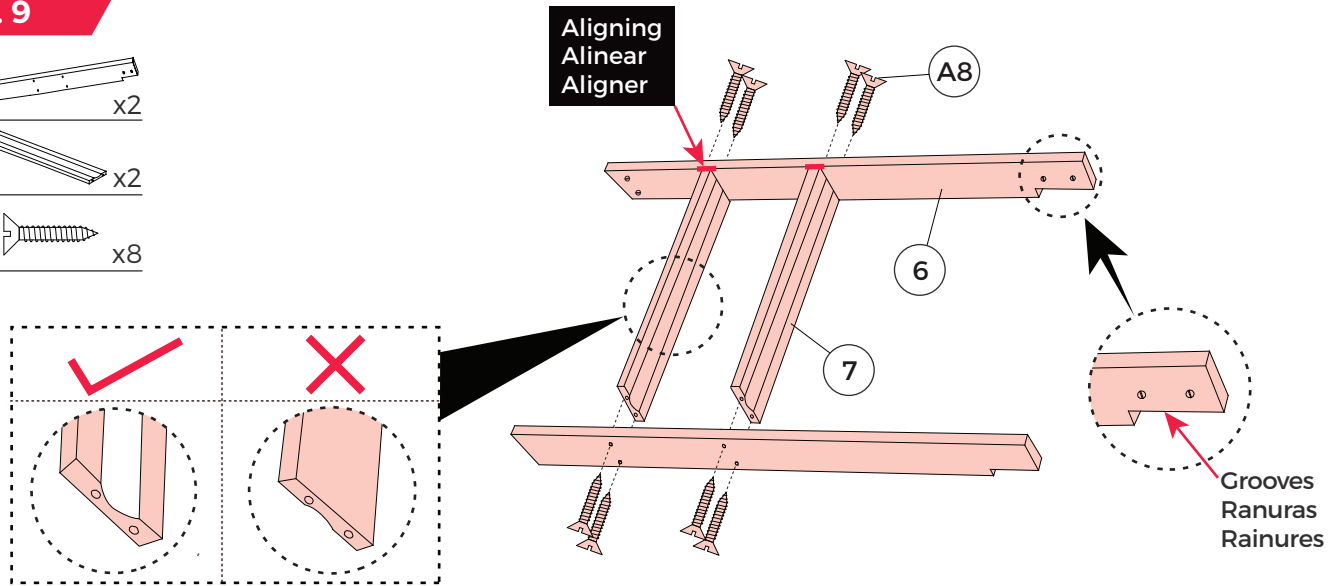

FIG. 10

- 8 x1
- 9 x1
- A7 x8

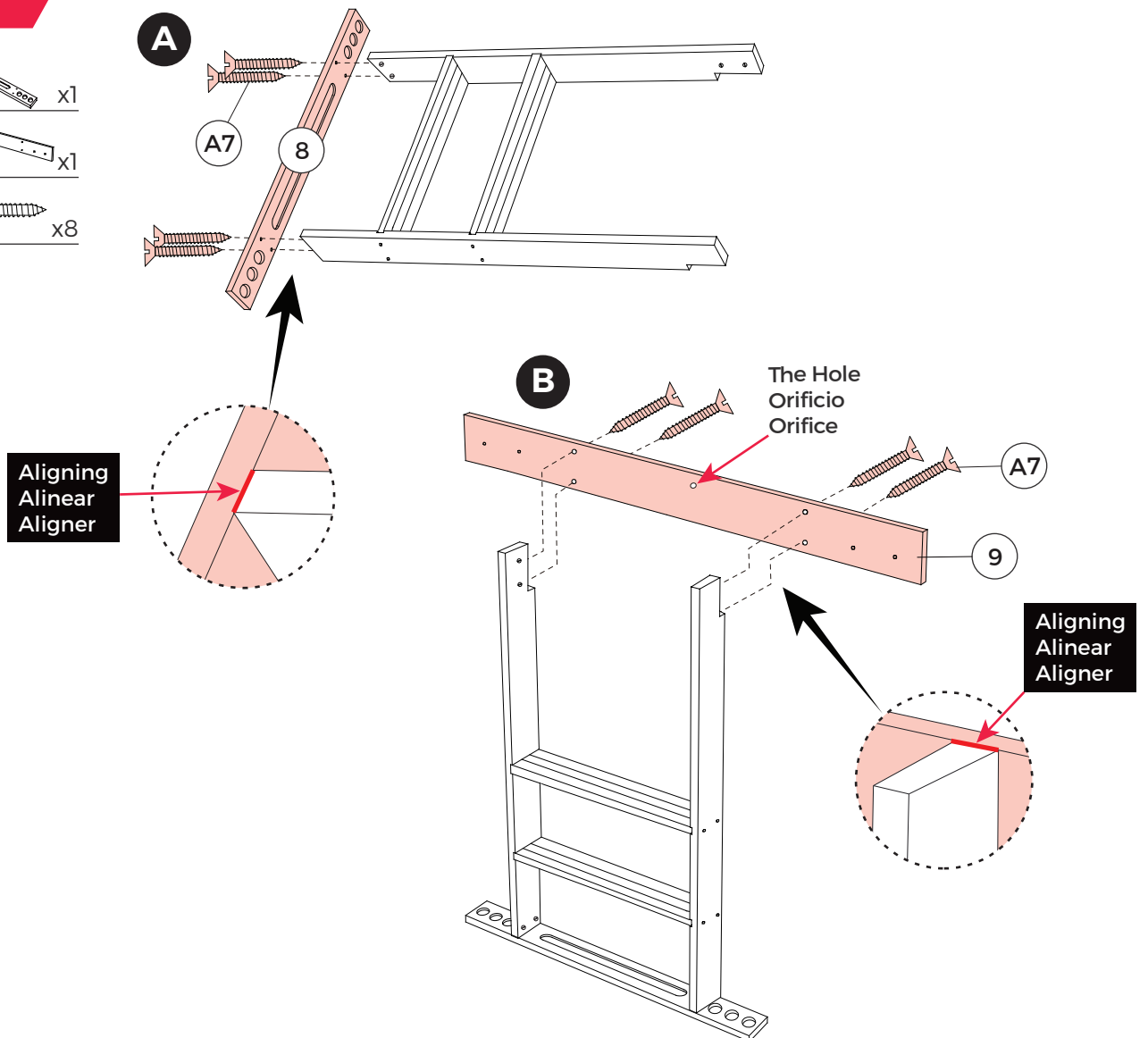
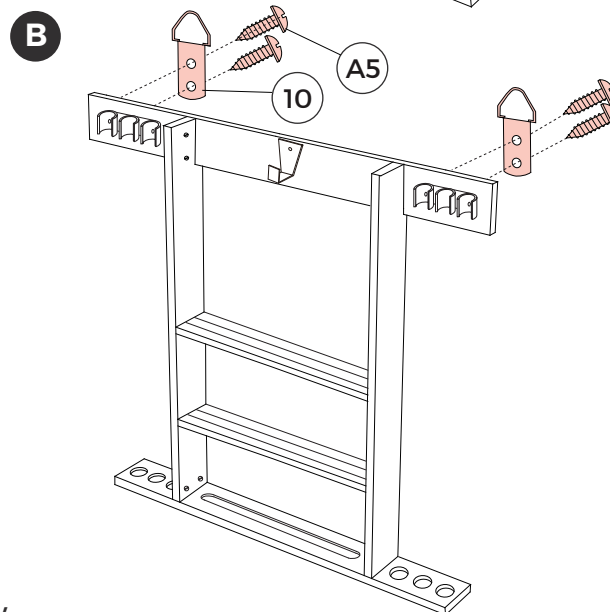
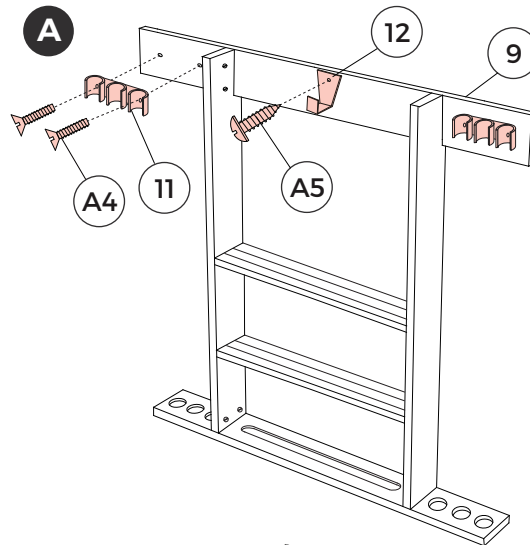
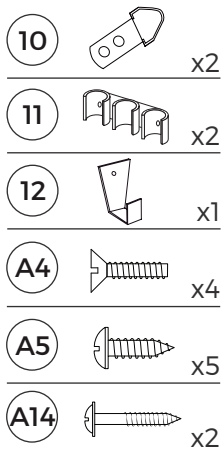
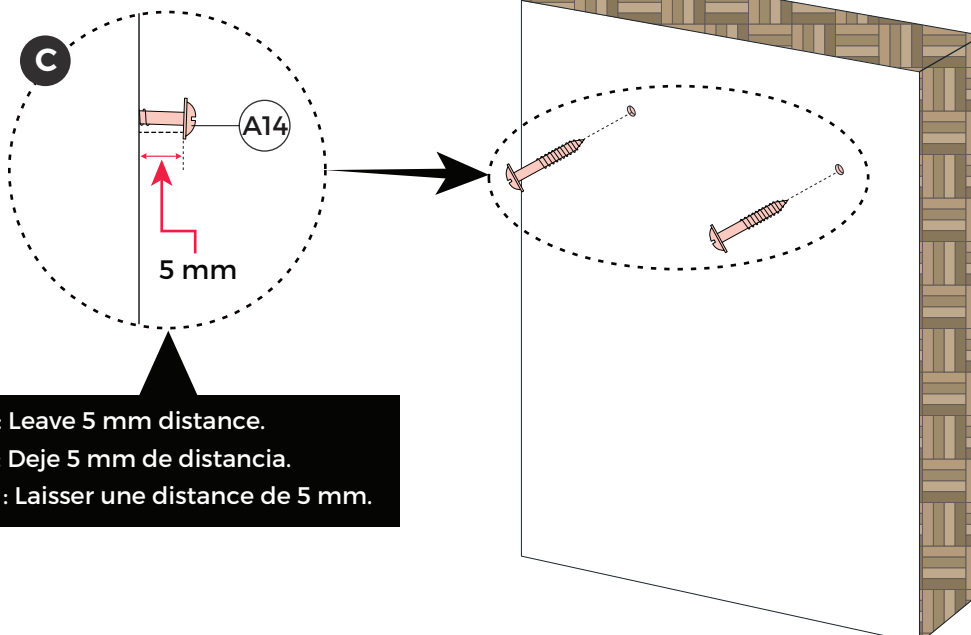



FIG. 11

SIDE VIEW
VISTA LATERAL
VUE LATÉRALE



Note: Leave 5 mm distance.
Nota: Deje 5 mm de distancia.
Note : Laisser une distance de 5 mm.

FIG. 12

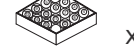
- 20  x2
- 21  x1
- 24  x1

