

Armoire  
Armoire  
Armario

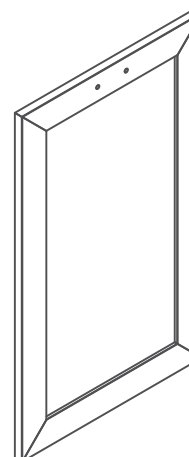

Get ready for assembly!  
Préparez-vous à l'assemblage!  
Prepárese para el montaje!

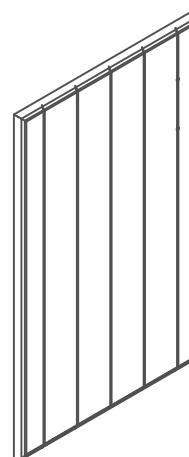
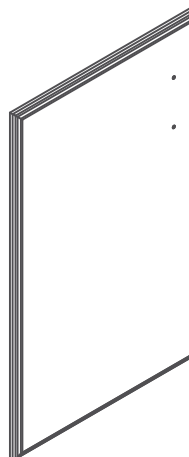
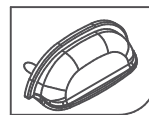
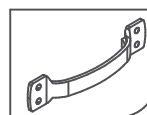
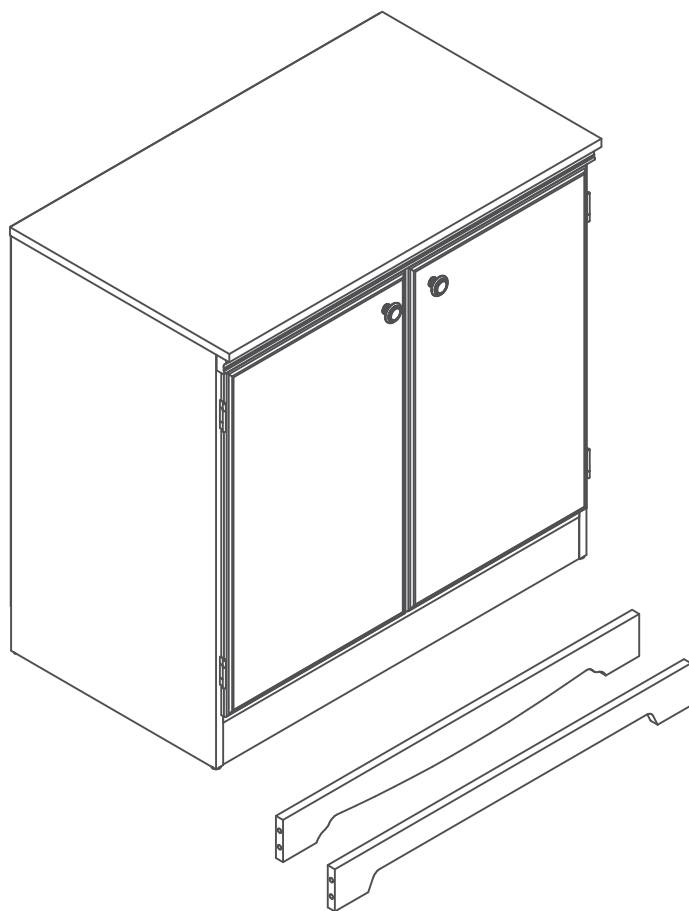

# WARRANTY / GARANTIE / GARANTÍA

## **5-year Warranty on furniture manufactured by us and 1 year warranty on other furniture and décor accesories.**

Our furniture is like family to us. And we never turn our back on family.

Our commitment to our furniture -- and to you -- doesn't end the minute you've purchased the piece. We offer a 5-year warranty on all of our manufactured furniture pieces.

1. We provides the original buyer with a warranty covering "defects" on furniture parts and workmanship for a period of 5 years from the date of purchase for products manufactured by us. We offer a 1-year warranty from the date of purchase to the original buyer on the products and decor accessories identified and presented with this warranty. The 1-year warranty covers defects on parts and workmanship.

2.The word defect" as used in this warranty is defined as any imperfection that may impair the use of the product for which it was intended.

3.This warranty is s trictly limited to the repair or replacement of defective components and parts. This warranty excludes all other direct or indirect charges and expenses according to the limit permitted by law in your state/province.

4.In the event can not replace a part its responsibility can not exceed the value or cost of production of that part or the replacement retail value of the defective item,

5.This warranty only applies under conditions of normal domestic use. It does not cover defects resulting from intentional damage, negligence, abuse, commercial use, product modification, accidents, exposure to the elements,or maintenance that does not comply with the guidelines in the assembly guide.

The warranties offered by us do not apply to the products of our partners on the Local showcase section of the web site ; each of those partners/ manufacturers sell its products on our web platform but offer its own warranty and details can be found on the product page of applicable products.

## **10-year Warranty on Workplace products BIFMA tested and 5-year / 2-year on height-adjustable working tables**

1. Our provides the original buyer with a warranty covering "defects" on furniture parts and workmanship for a period of 10 years from the date or purchase Workplace BIFMA tested products.

2. Our Furniture provides the original buyer of a height-adjustable table with a 5-year warranty from the date of purchase on the structure elements and a 2-year warranty on the electronic components. This warranty covers defects on parts and workmanship.

3. The word "defect" as used in this warranty is defined as any imperfection that may impair the use of the product for which it was intended.

4. This warranty is strictly limited to the repair or replacement of detective components and parts. This warranty excludes all other direct or indirect charges and expenses according to the limit permitted by law in your state/province.

5. In the event can not replace a part its responsibility can not exceed the value or cost of production of that part or the replacement retail value of the defective item,

6. This warranty only applies under conditions of normal use. It does not cover defects resulting from intentional damage, negligence, abuse, product modification, accidents,exposure to the elements, or maintenance that does not comply with the guidelines in the assembly guide.

7. When applying this warranty reserves the right to ask for the proof of purchase of the original buyer.

8. This warranty is only valid on purchases made at authorized retailers in Canada, the U.S.A. and Mexico.

## **30-day return policy on décor accessories**

If you are not completely satisfied with a non-furniture item you purchased, please contact us within 30 days of delivery to arrange for the exchange of, or a refund on, your unused item. We will send a courier over to take the item from your home. You will be charged a return shipping fee equal to 15% of the cost of the items returned. We reserves the right to refuse a return or an exchange if any condition is not met.

### **We do not accept:**

Returns unless the item is unused and in its original packaging.

Returns or exchanges on bedding (comforters, duvet covers, coverlets, bedsheets, pillows, duvets, and crib sets) that has been opened or used, or on any product that has been modified, altered or washed.

Returns on any mattress or stuffed/upholstered products without their legal label.

## WARNING / AVERTISSEMENT / ADVERTENCIA

Serious or fatal crushing injuries can occur from furniture tip-over. To help prevent tip-over :

- Place heaviest items in the lowest drawers.
- Do not set TVs or other heavy objects on the top of this product.  
Never allow children to climb or hang on drawers, doors, or shelves.
- Never open more than one drawer at a time.
- Use of tip-over restraints, only reduces, but does not eliminate, the risk of tip-over.

Des blessures graves ou fatales peuvent résulter du basculement du meuble.  
Afin d'éviter le basculement :

- Placer les items les plus lourds dans les tiroirs du bas.
- Ne placer pas de TV ou d'autres objets lourds sur ce produit.  
Ne jamais laisser un enfant grimper sur les tiroirs, les portes et les tablettes ou s'accrocher à ceux-ci.
- Ne jamais ouvrir plus d'un tiroir à la fois.

**L'utilisation de dispositif anti-basculement ne peut que réduire les risques de basculement, sans les éliminer totalement.**

El volcadura del mueble puede ser causa de lesiones graves o de un atropellamiento fatal. Para evitar la volcadura :

- Ponga las cosas pesadas en los cajones mas bajos.
- No ponga televisores u otros objetos pesados encima de este producto. Nunca permita que un niño se suba o se cuelgue en cajones, puertas o estantes.
- Nunca abra mas de un cajon a la vez.

**El uso de sujetadores para evitar la volcadura solo puede disminuir el riesgo de una volcadura, pero no lo elimina.**

# 1

Let's get handy!

Mettons-nous au travail ! / ¡ Vamos a ponernos prácticos !

01

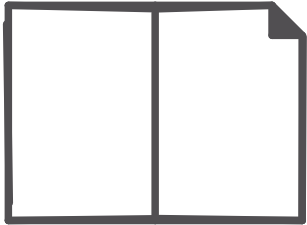

02

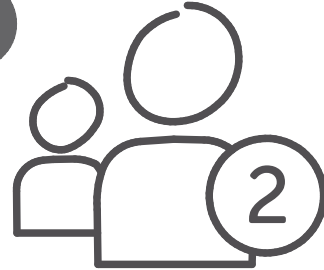

03

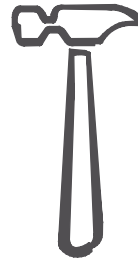
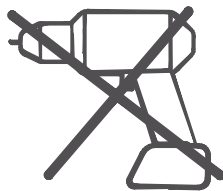

04

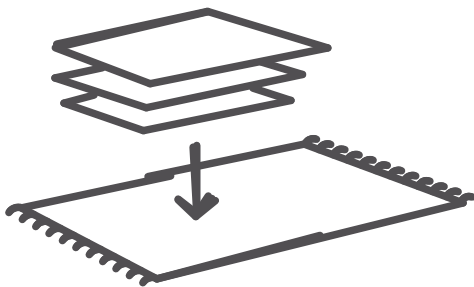

05

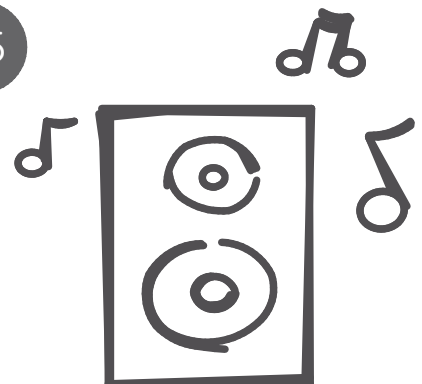

# 2

Collect the pieces together  
Rassembler les morceaux ensemble  
Poner las piezas juntas

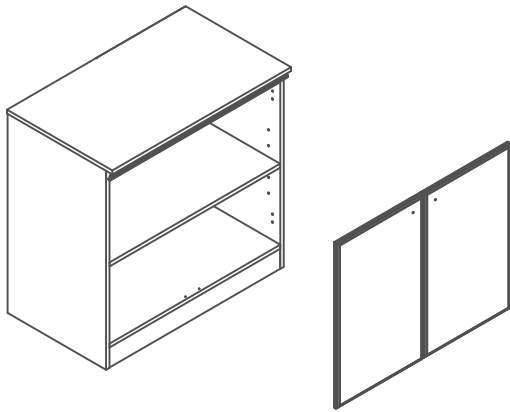

The image may differ depending on model  
L'image peut différer selon le modèle  
La imagen variará dependiendo del modelo

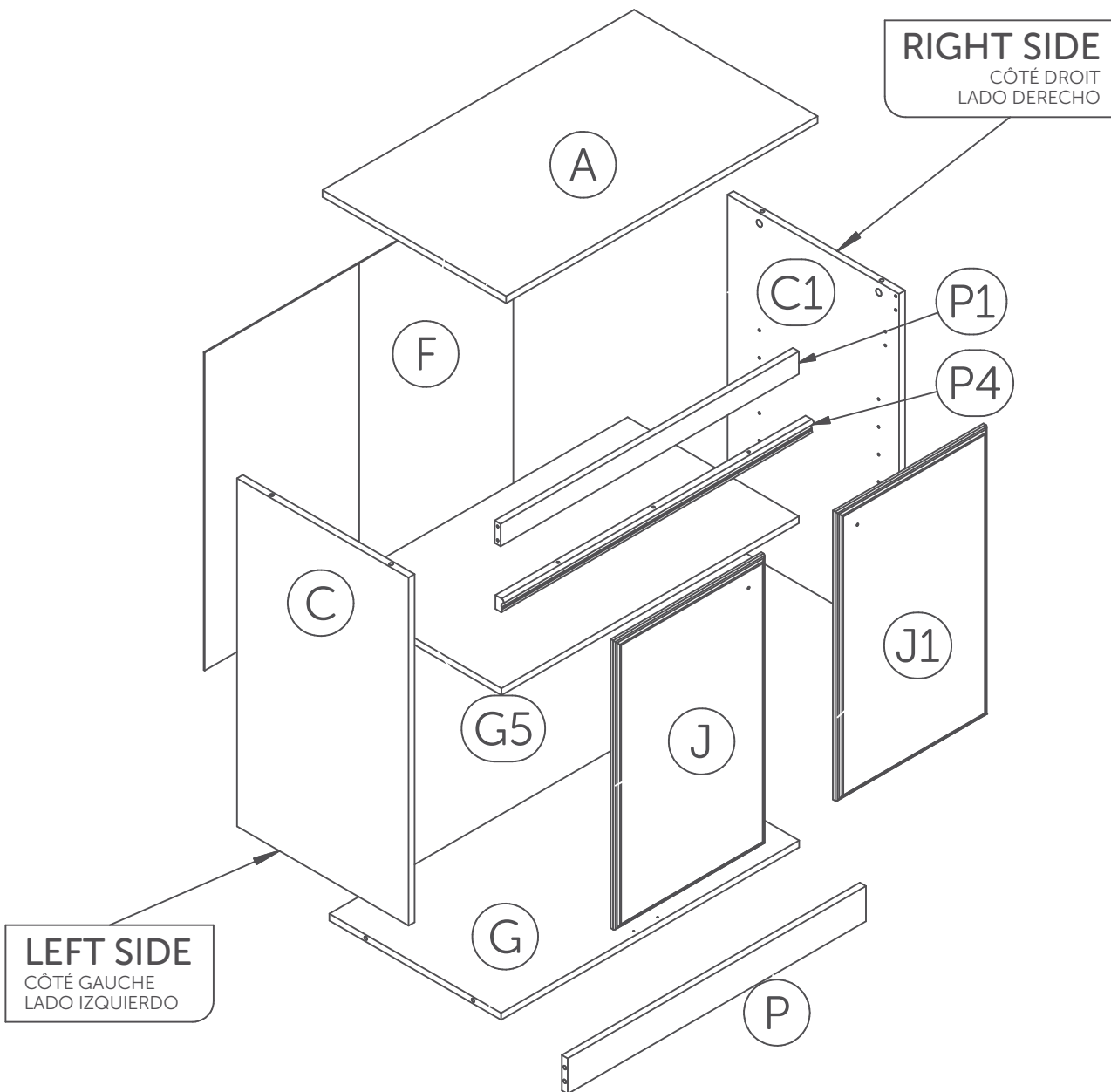

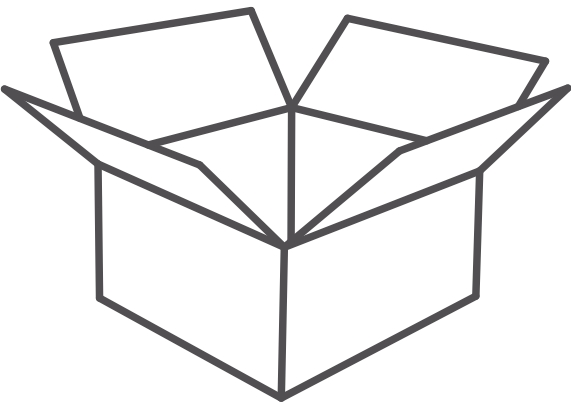

The image may differ depending on model  
L'image peut différer selon le modèle  
La imagen variar dependiendo del modelo

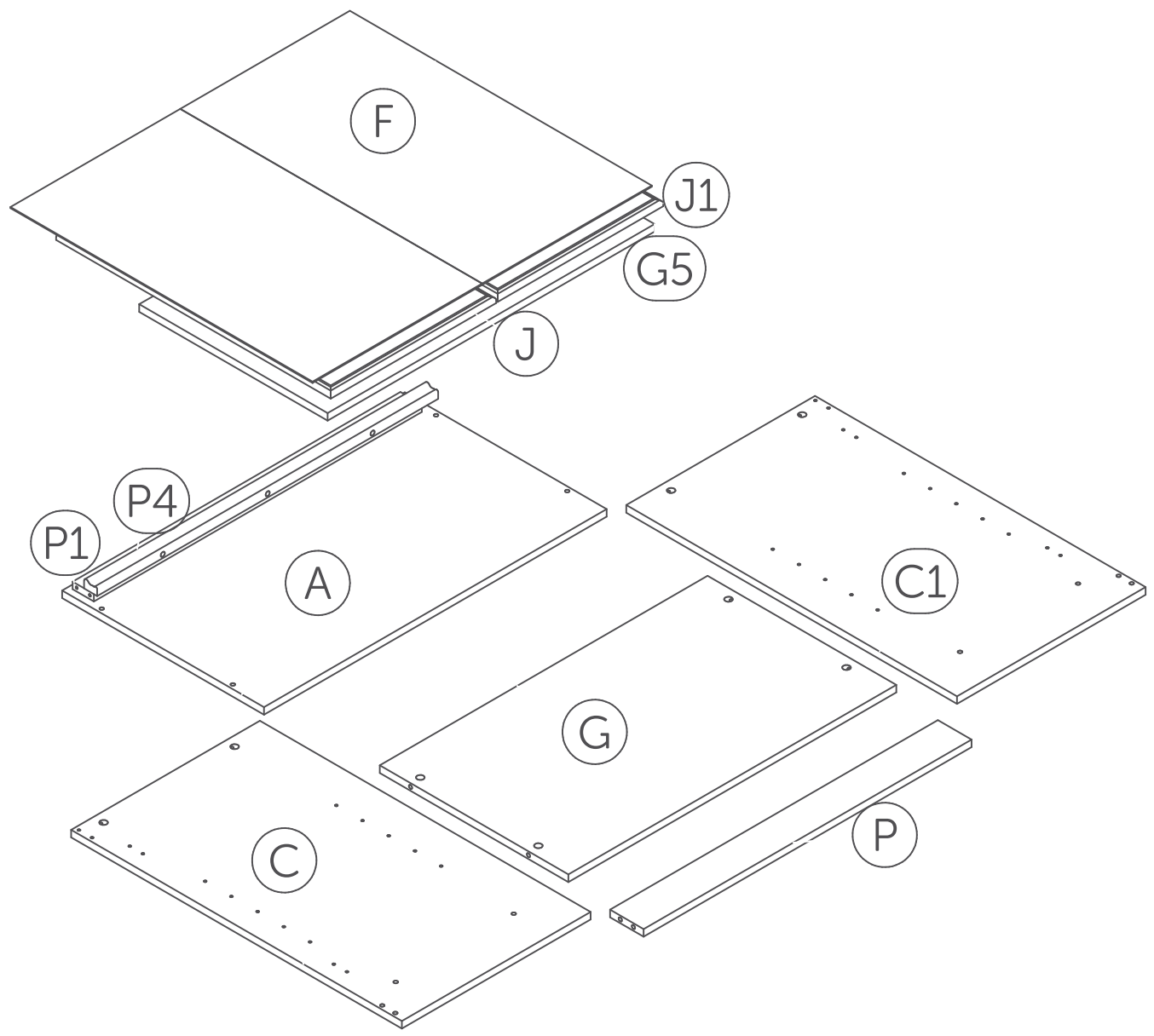

# 3

## Collect the hardware Rassembler la quincaillerie Reunir los artículos de ferretería

1 : 1



Full scale  
Taille réelle  
De tamaño real

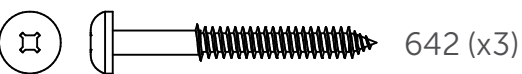
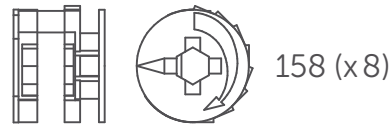
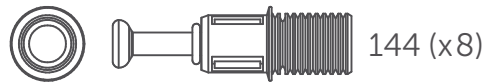
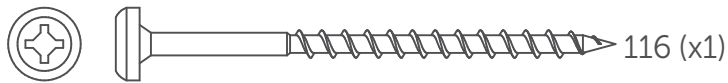
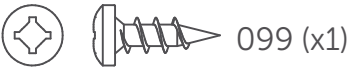
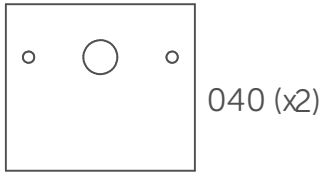

Or  
Ou  
O

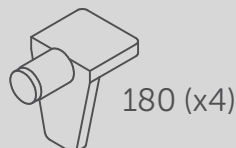
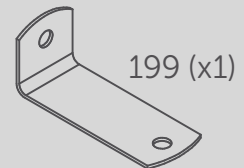
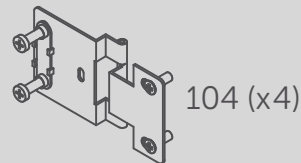
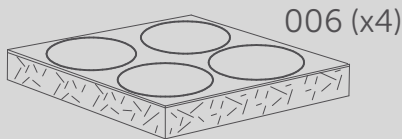

\*Hardware package may have spare parts.  
\*Le sac de quincaillerie peut contenir des pièces de remplacement.  
\*La bolsa de herraje puede contener piezas adicionales de repuesto.

# 4

Collect the hardware by model

Rassembler la quincaillerie selon le modèle /

Reunir los artículos de ferretería según el modelo

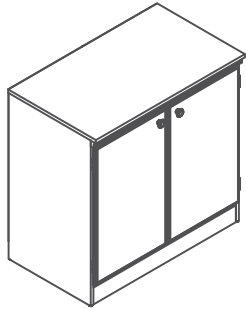
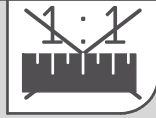
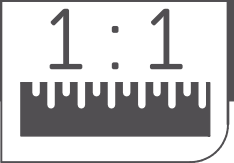

380 (x2)

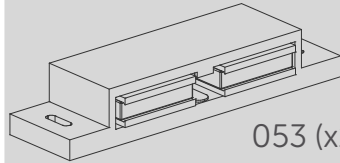

053 (x1)



121 (x2)



148 (x2)

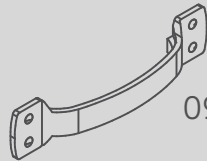
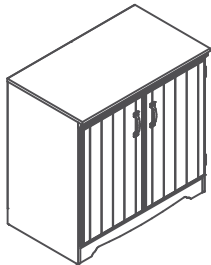

098 (x2)



135 (x4)

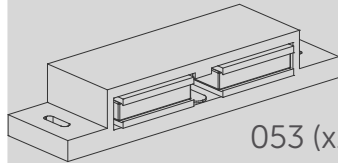
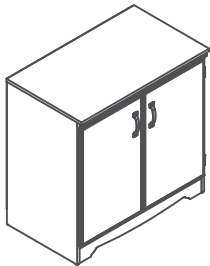

053 (x1)



148 (x2)

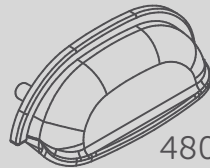
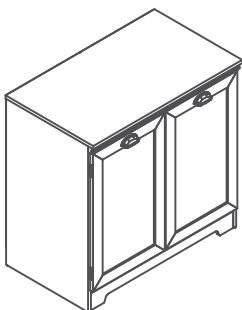

480 (x2)



129 (x4)

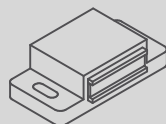

050 (x2)



148 (x4)

# 5

## Things to remember for assembly

À retenir lors de l'assemblage

A recordar durante el ensamblaje

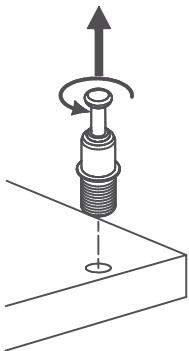
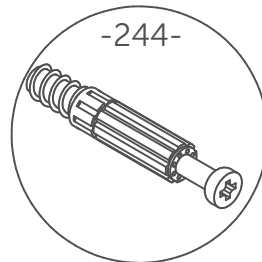
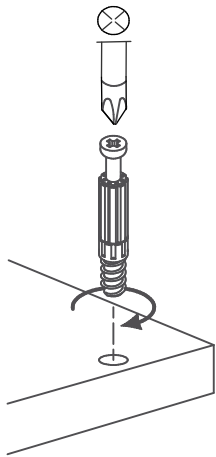
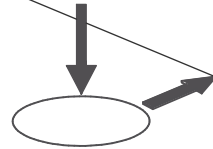
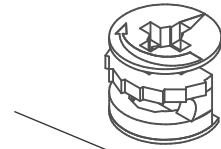
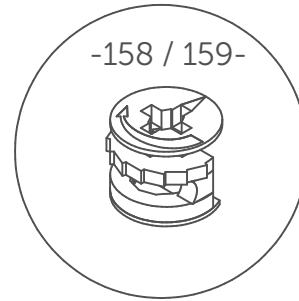
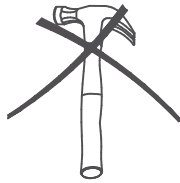
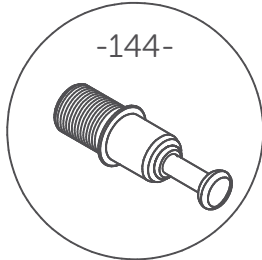
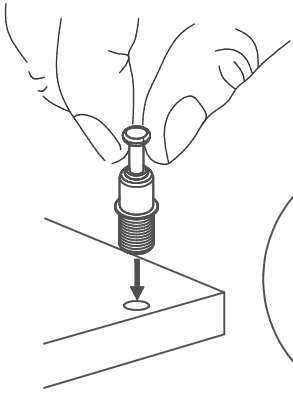

To remove: Twist and pull  
 Pour enlever: Tourner et tirer  
 Para retirar: Girar y tirar

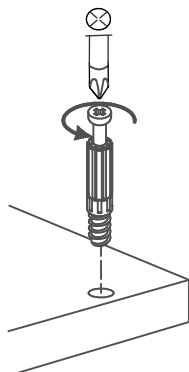
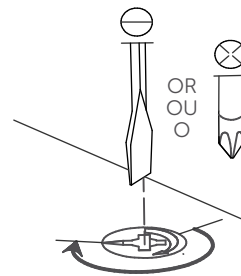

To remove: unscrew  
 Pour enlever: dévisser  
 Para retirar: desatornillar

Screw past the halfway point  
 Visser plus qu'un demi tour  
 Atornillar más de media vuelta

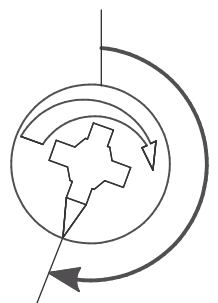

# 6

## 6.1

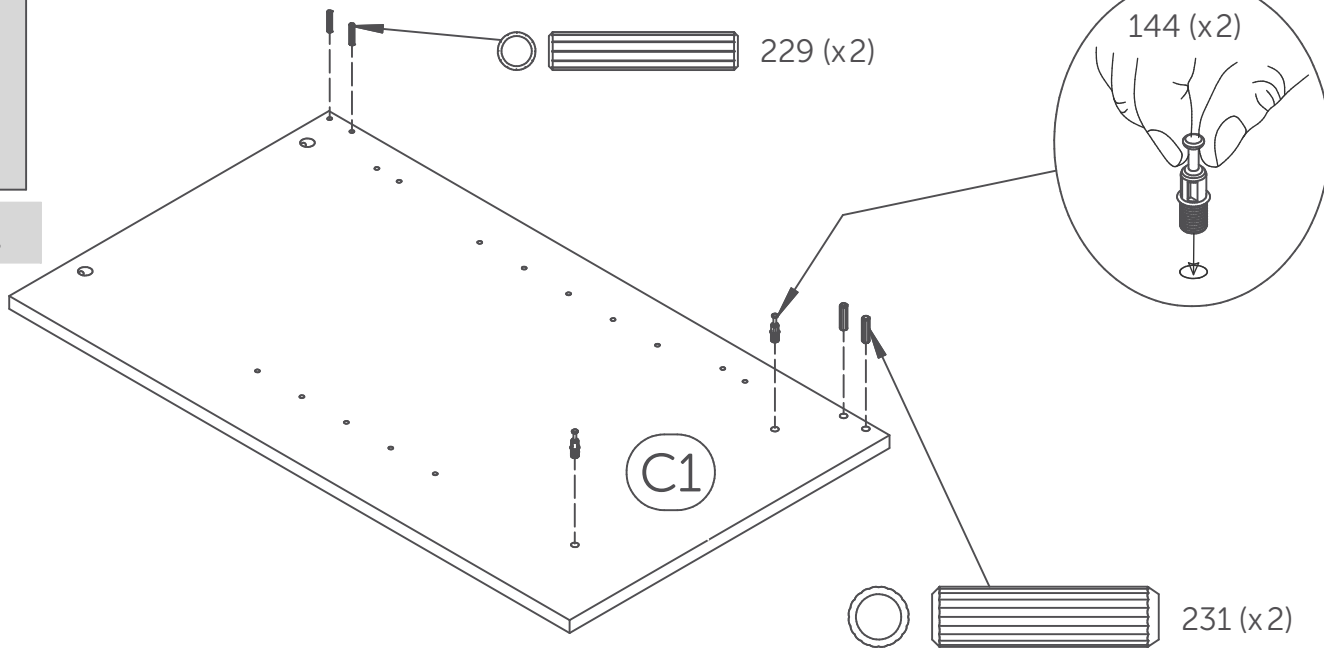

## 6.2

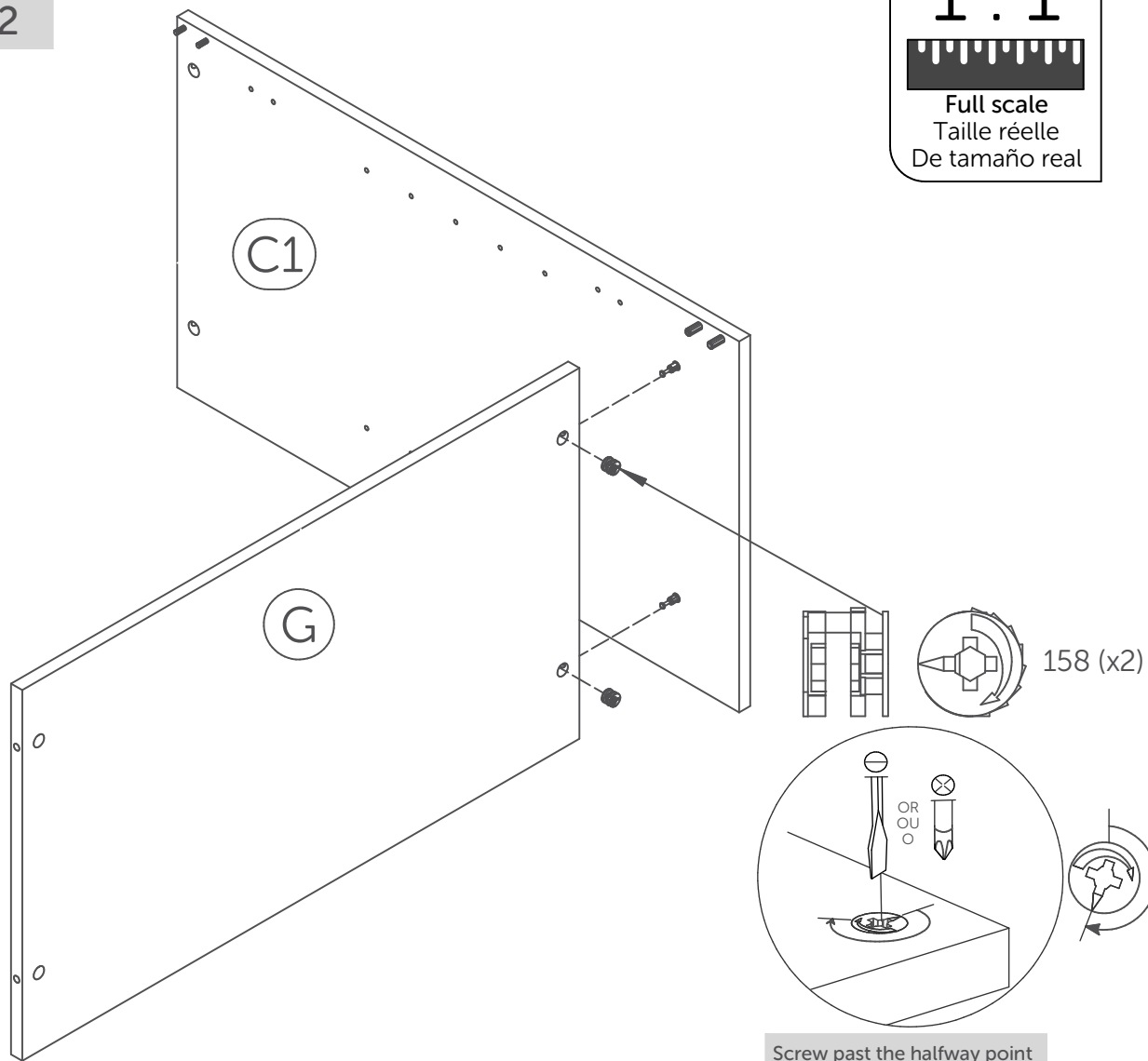

Screw past the halfway point  
Visser plus qu'un demi tour

# 7

## 7.1

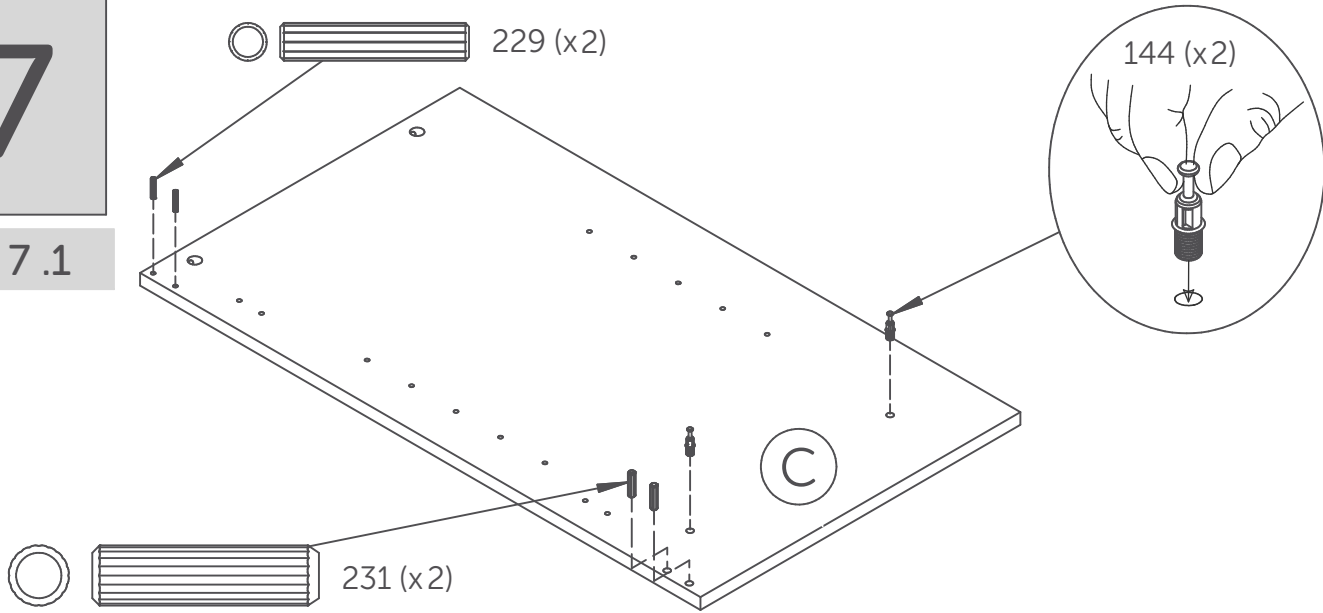

## 7.2

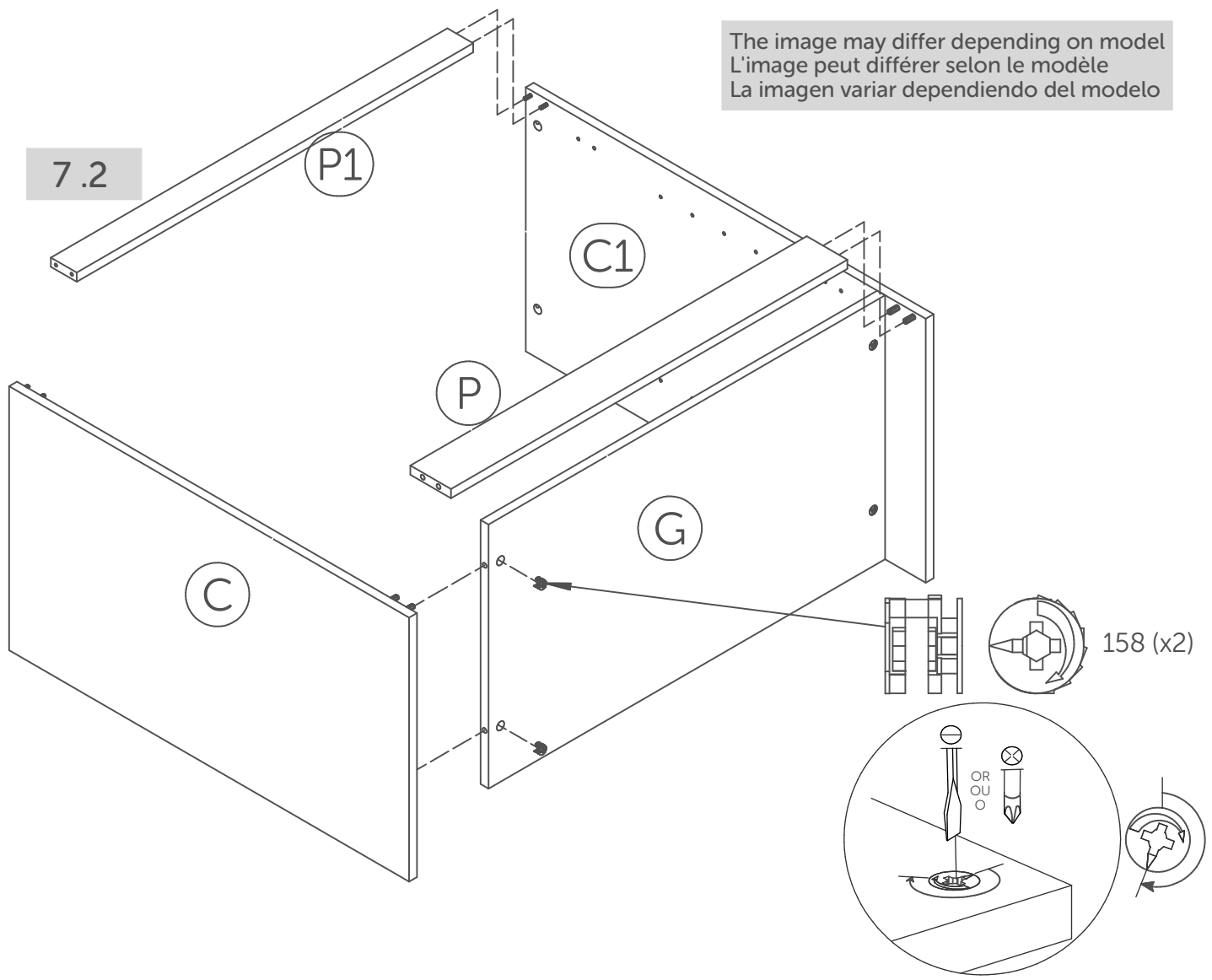

The image may differ depending on model  
L'image peut différer selon le modèle  
La imagen variará dependiendo del modelo

Screw past the halfway point  
Visser plus qu'un demi tour

# 8

## 8.1

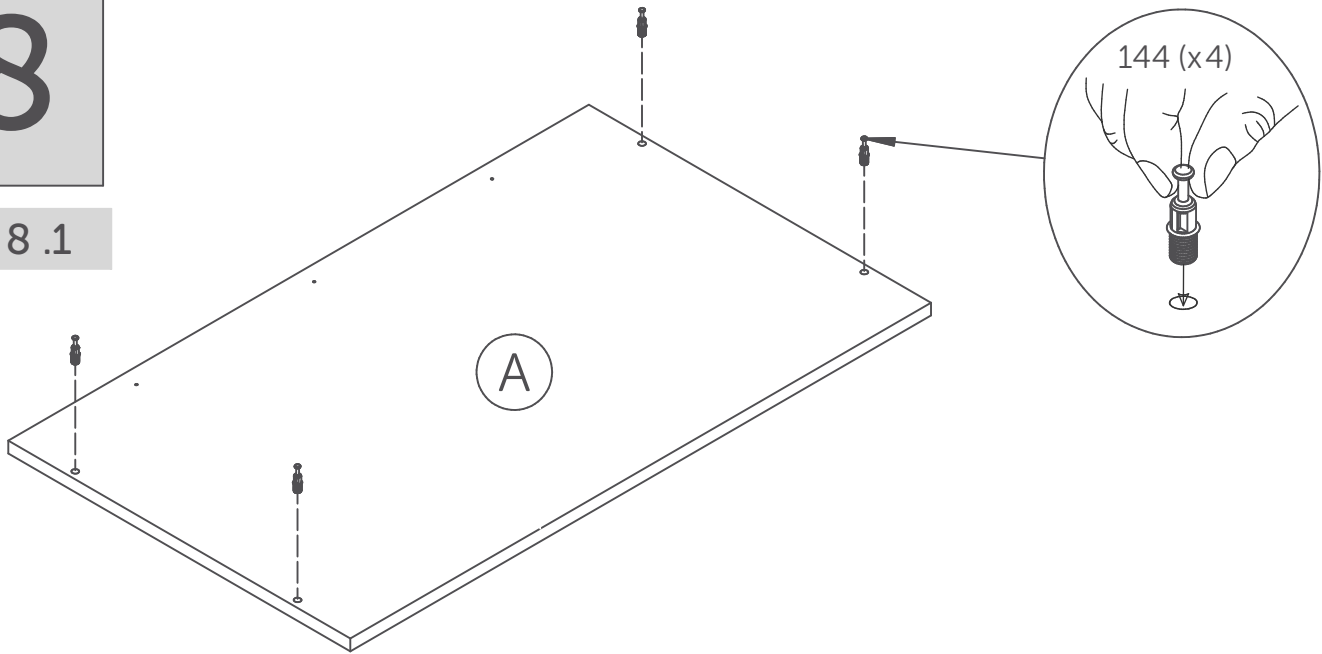

## 8.2

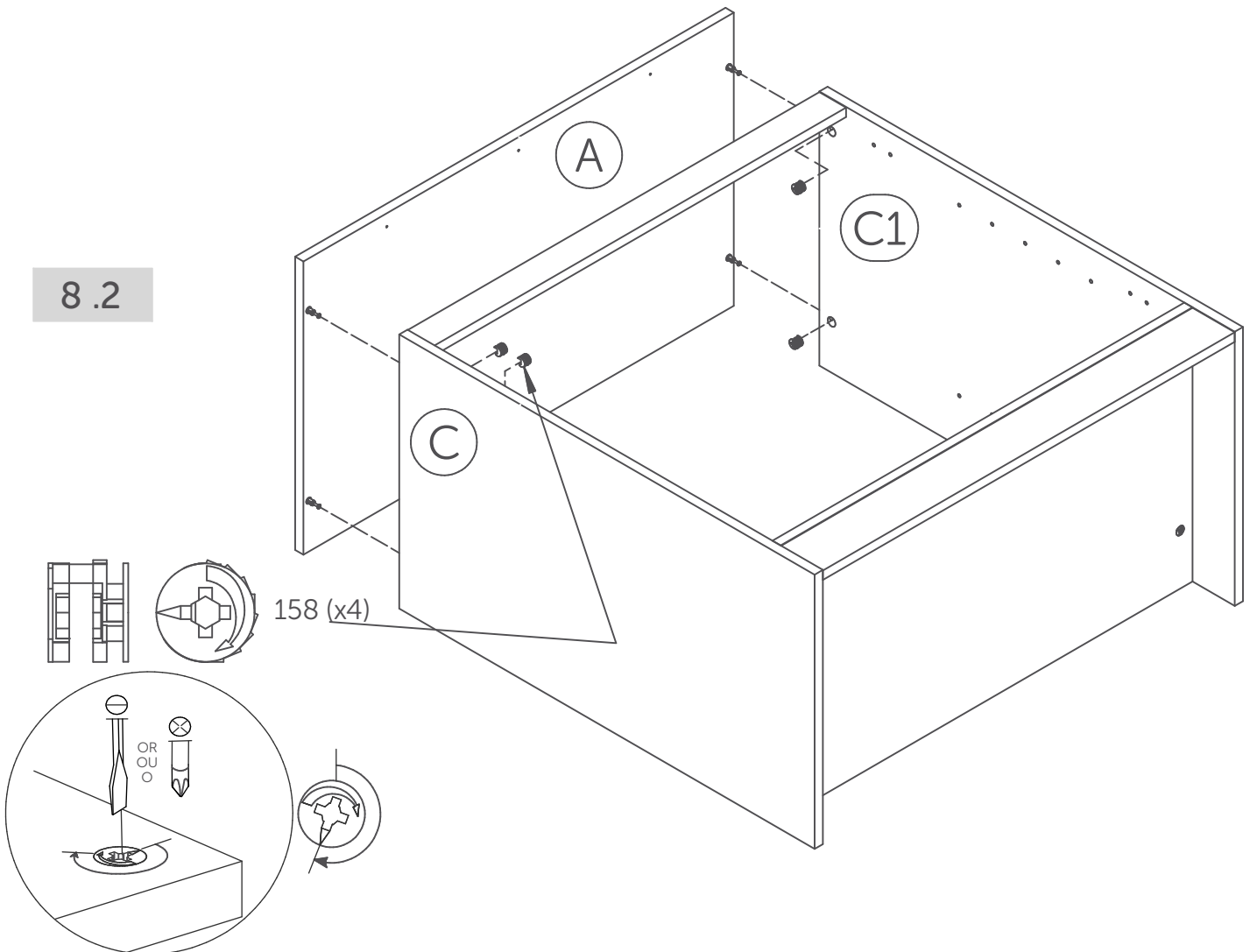

Screw past the halfway point  
Visser plus qu'un demi tour

9

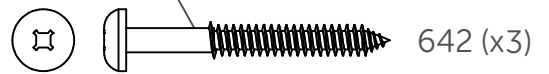
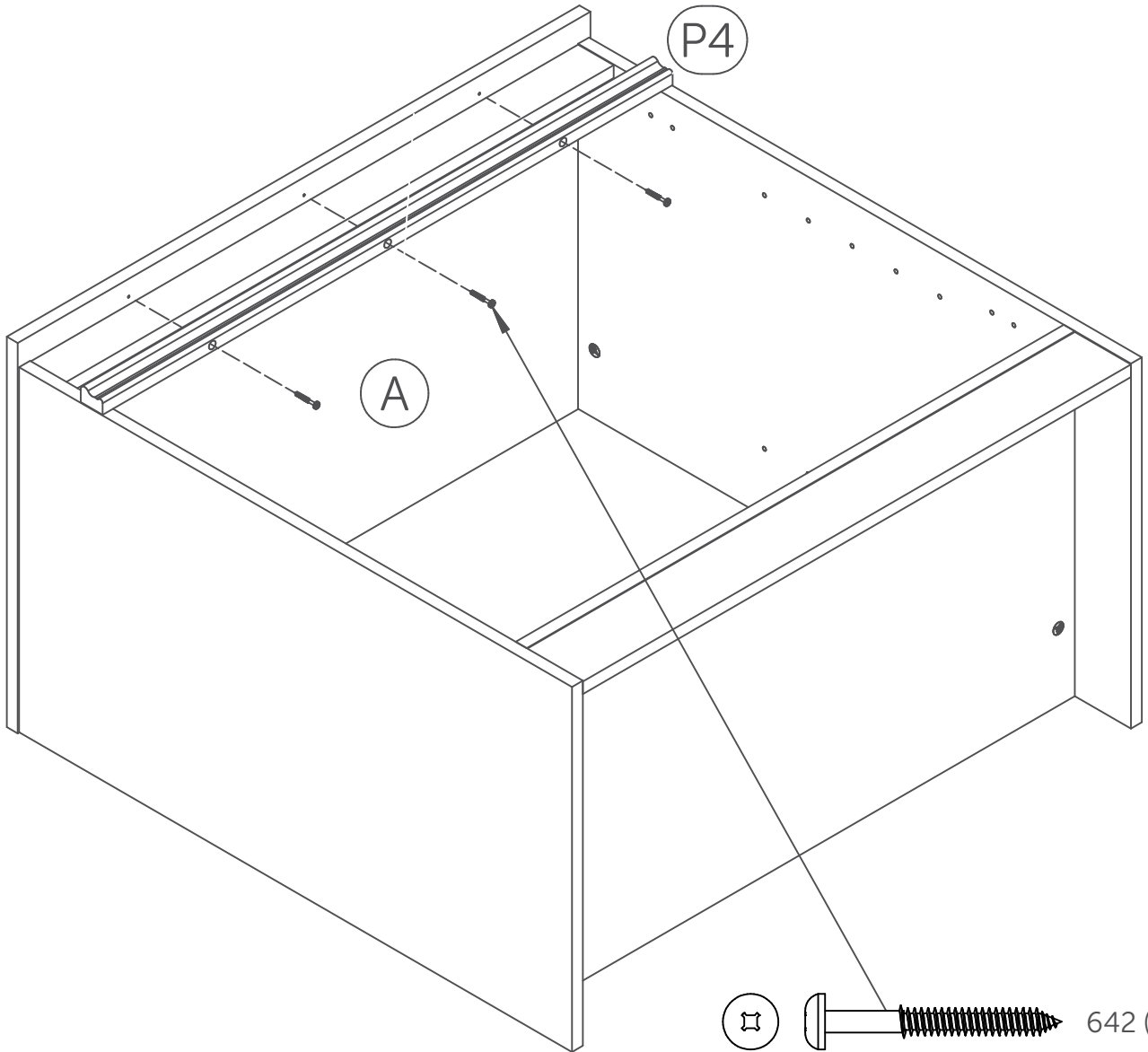
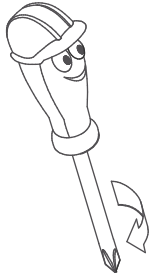

Or  
Ou  
O



# 10

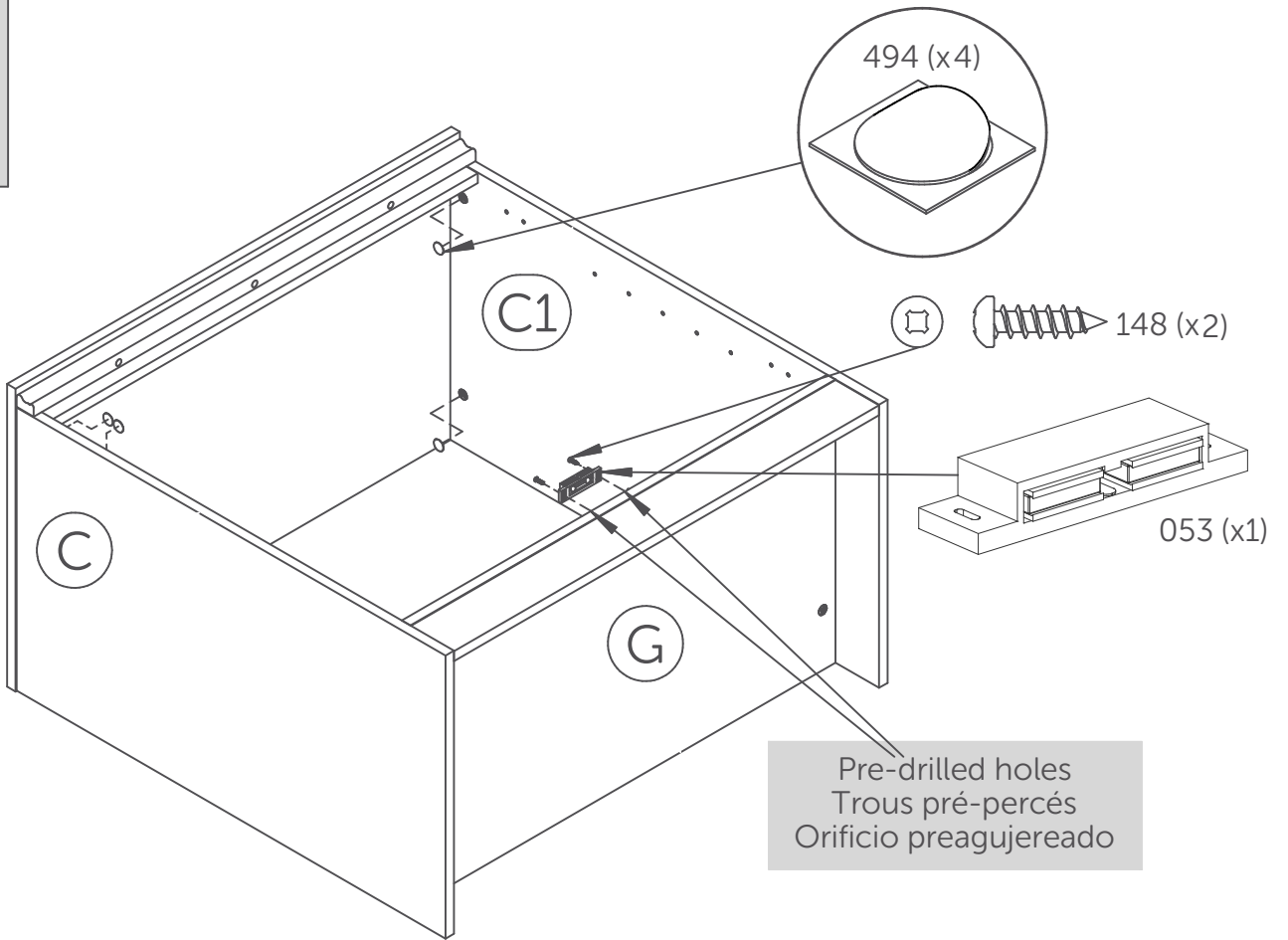

Model/Modèle/Modelo  
**14132**

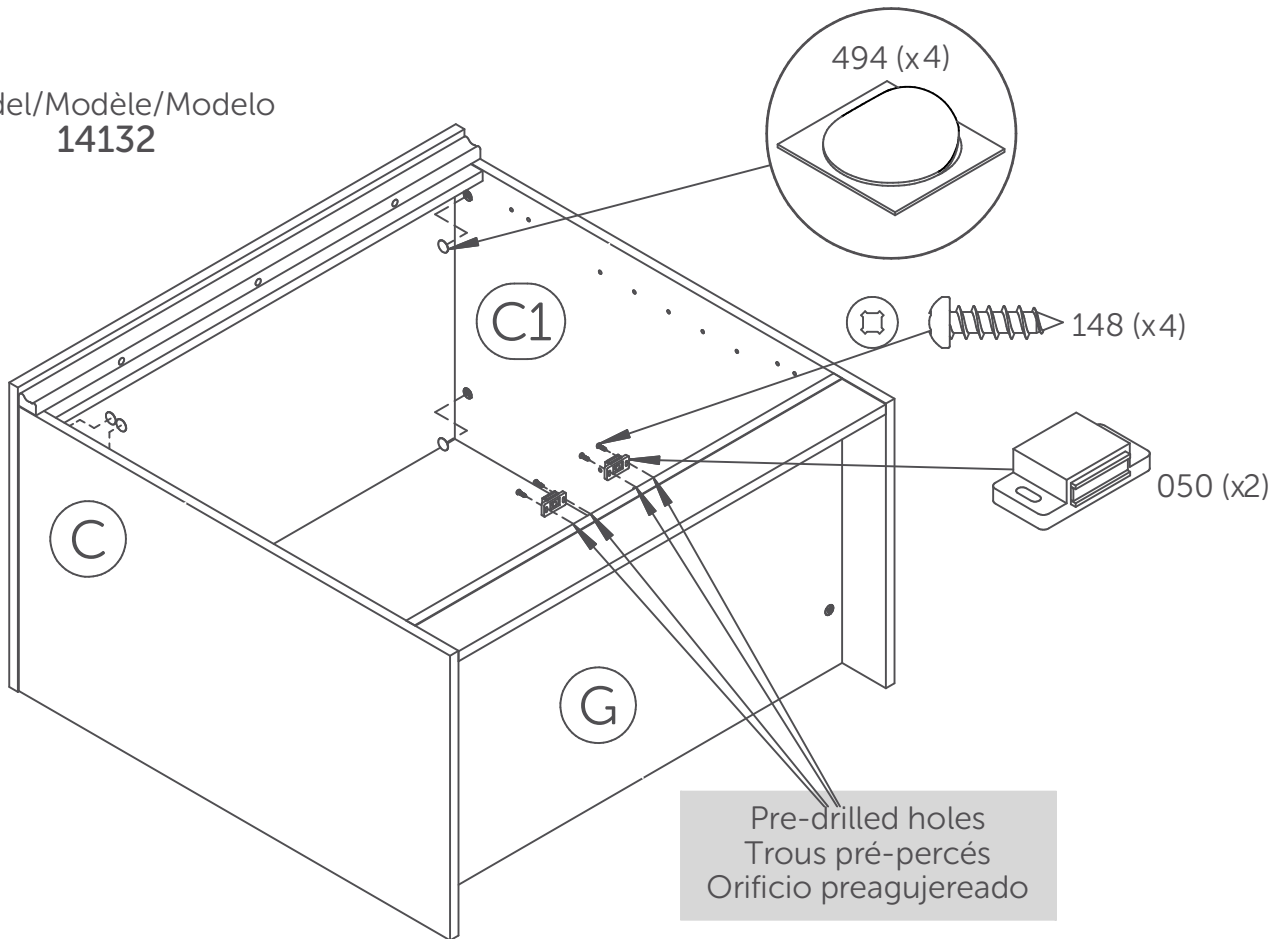

# 11

## Flip furniture on its front

Tourner le meuble sur la face

Girar el mueble sobre la cara frontal

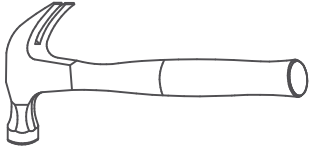

090 (x26)

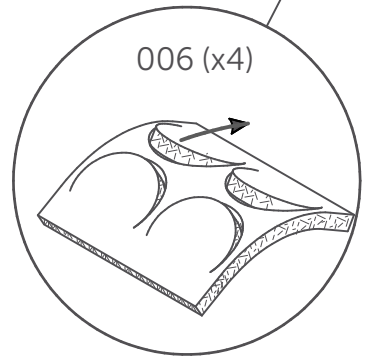
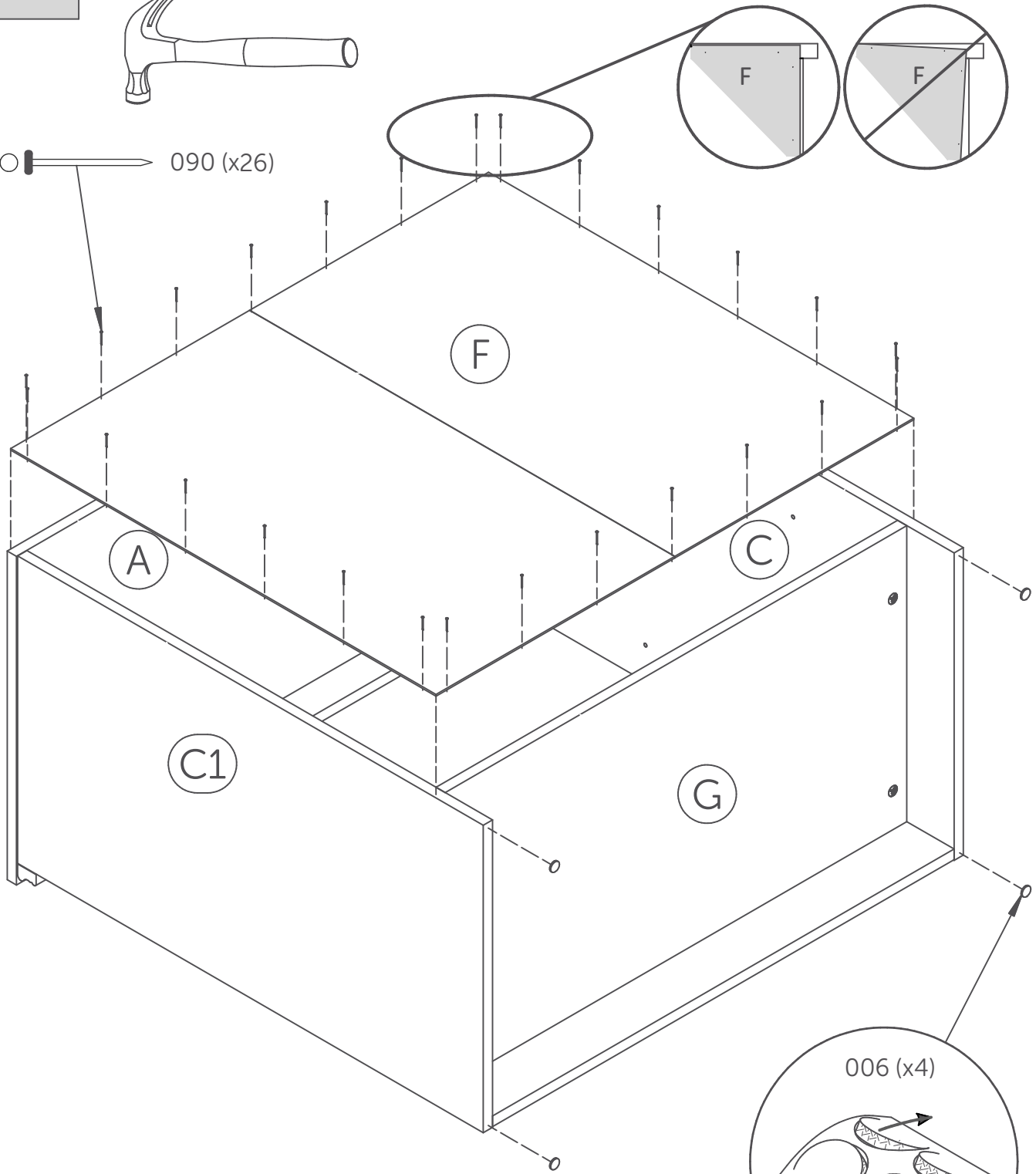

**IMPORTANT:** Tipping can injure young children. Use of this safety hardware is **highly recommended**. This safety hardware, when properly installed, can provide protection against unexpected accidental tipping of furniture due to improper use.  
**If the safety bracket is not include in the box, please contact the consumer service in order to obtain one before using the furniture.**

**MISE EN GARDE :** Le basculement du meuble peut blesser un enfant. L'utilisation de l'équerre de sécurité est **hautement recommandée**. Cette quincaillerie de sécurité, si installée correctement, peut offrir une protection contre le basculement inattendu du meuble.  
**Si le crochet est absent, veuillez contacter notre service aux consommateurs pour obtenir cette pièce avant utilisation.**

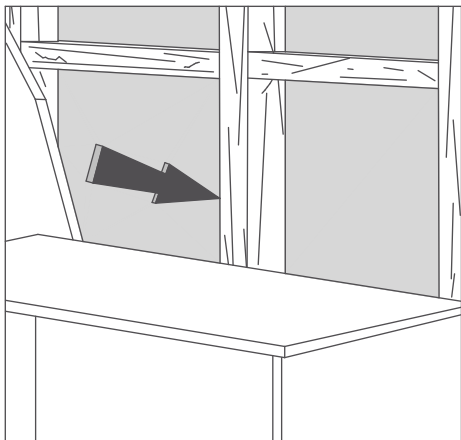
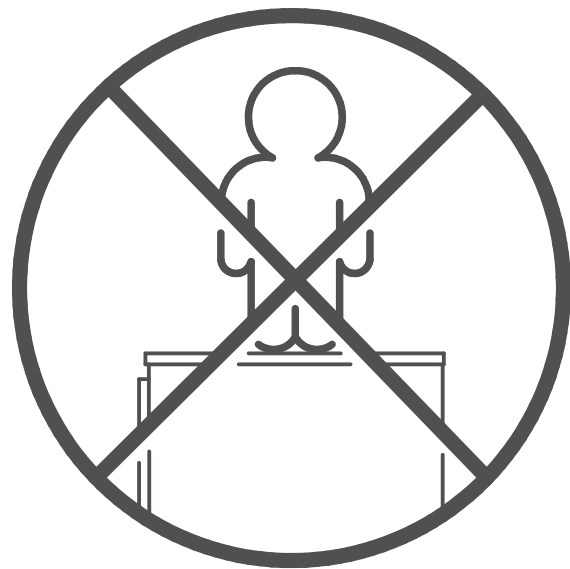

**Locate a wall stud:**

- Move the furniture unit to its final position to the wall.
- Locate a wall stud behind the furniture unit.
- \*It doesn't have to be centered.

**Localiser le montant de mur :**

- Placer le meuble à l'endroit désiré.
- Localiser le montant de mur derrière le meuble.
- \*Ne doit pas nécessairement être centré.

# 13

## 13.1

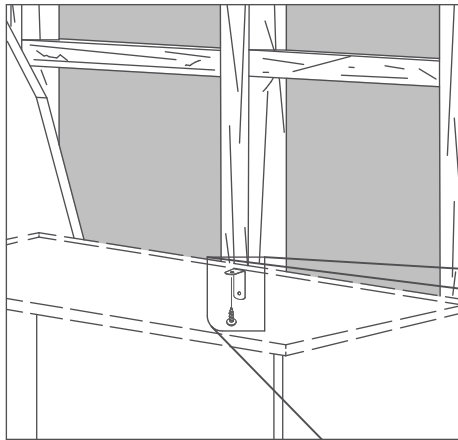

### Screw the safety bracket to the furniture:

- Screw the safety bracket under the top with 099 wood screw.

### Visser l'équerre de sécurité au meuble :

- Visser l'équerre de sécurité sous le dessus du meuble avec la vis à bois 099.

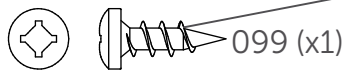
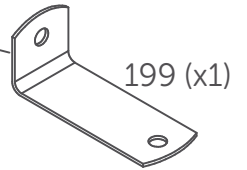
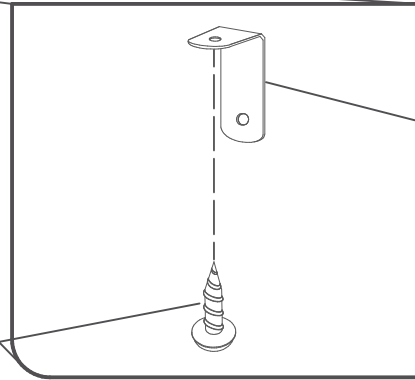

099 (x1)

## 13.2

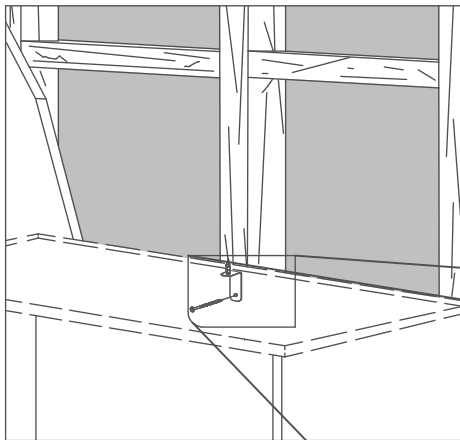

### Screw the furniture to the wall stud:

- Screw the 116 wood screw thru the 199 bracket, the back of the furniture and into the wall stud.
- Make sure the screws are firmly tighten to the wall and into the furniture.

### Visser le meuble au montant de mur :

- Visser la vis à bois 116 à travers l'équerre 199, le meuble et dans le montant de mur.
- S'assurer que l'équerre de sécurité est fermement vissée au montant du mur et au meuble.

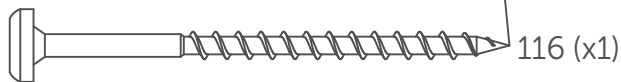
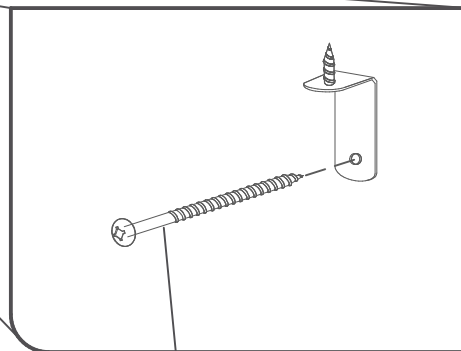

116 (x1)

**WARNING:** Use of tip-over restraints, only reduces, but does not eliminate, the risk of tip-over. Don't hesitate to contact us if you need help installing your safety bracket properly.

**MISE EN GARDE :** L'utilisation du dispositif anti-basculement ne peut que réduire les risques de basculement, sans les éliminer totalement. N'hésitez pas à nous contacter si vous avez besoin d'aide pour installer l'équerre de sécurité.

# 14

## 14.1

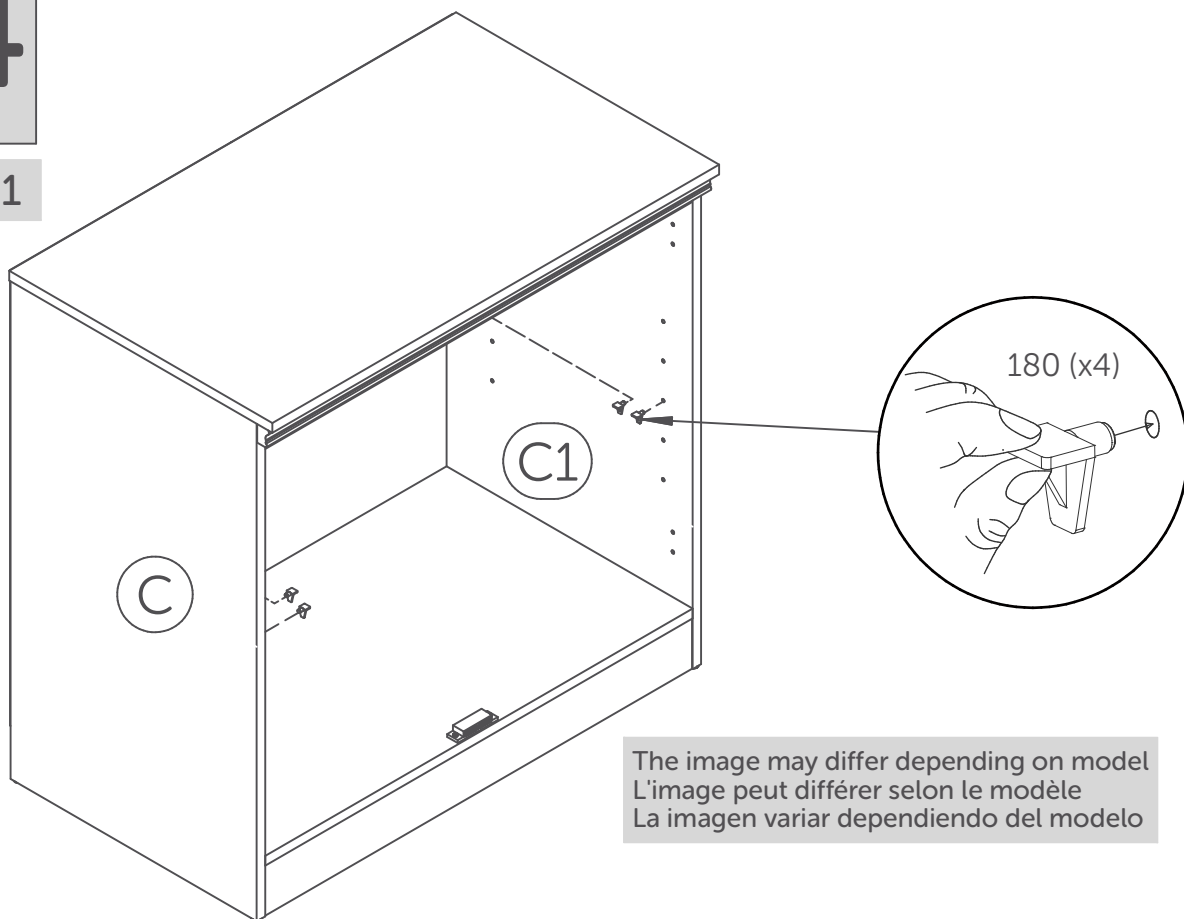

The image may differ depending on model  
L'image peut différer selon le modèle  
La imagen variar dependiendo del modelo

## 14.2

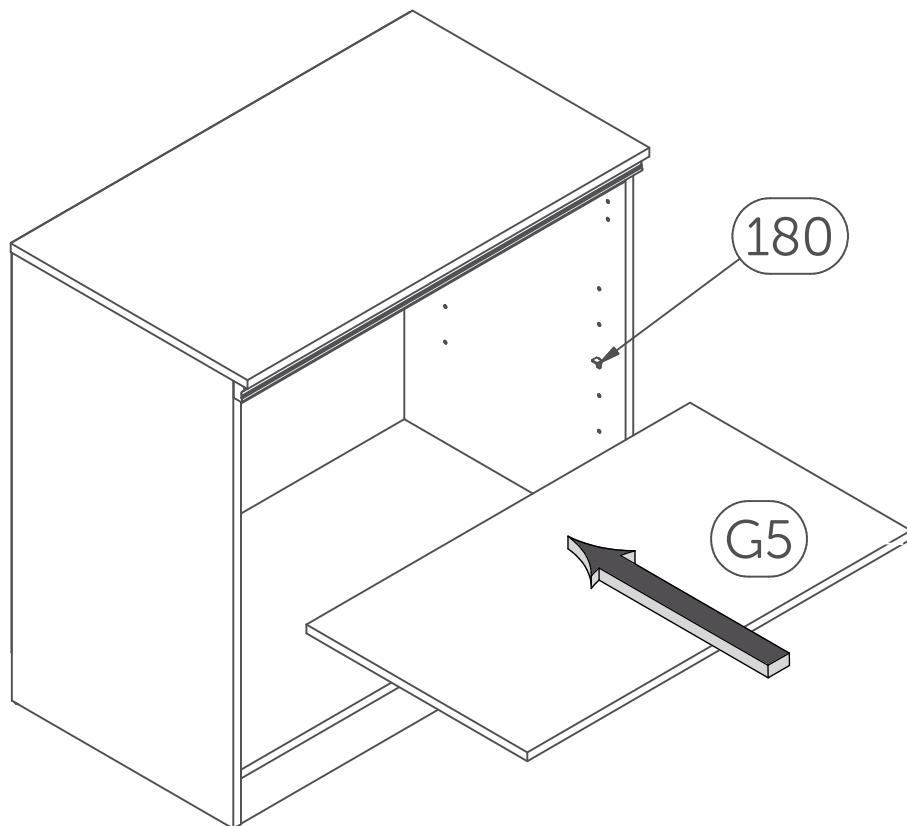

# 15

## 15.1

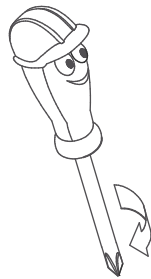
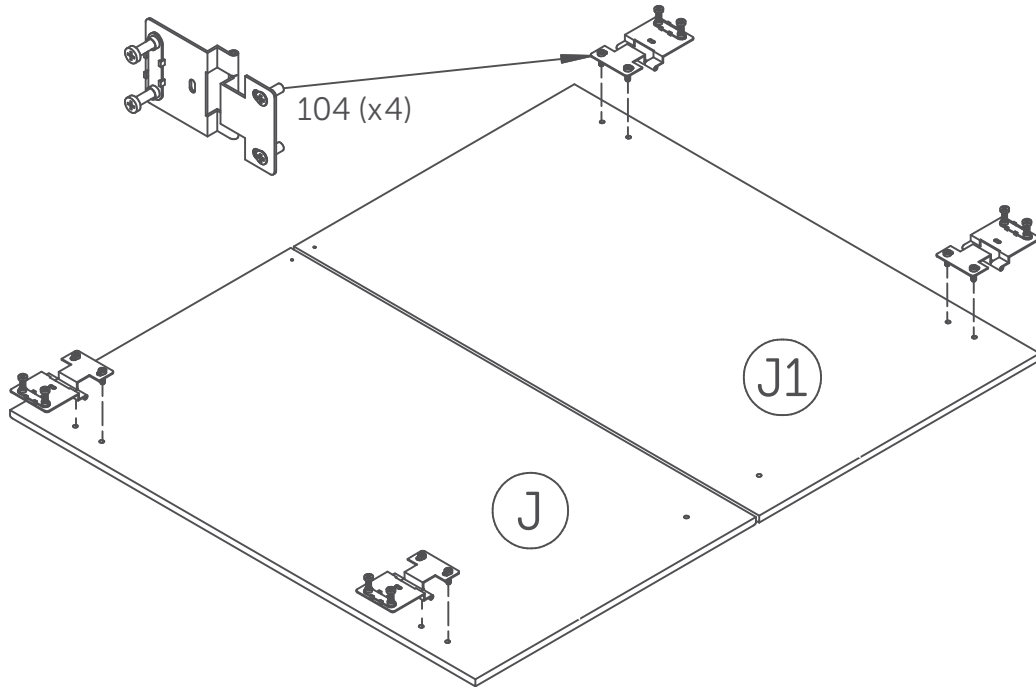

## 15.2

The image may differ depending on model  
L'image peut différer selon le modèle  
La imagen variará dependiendo del modelo

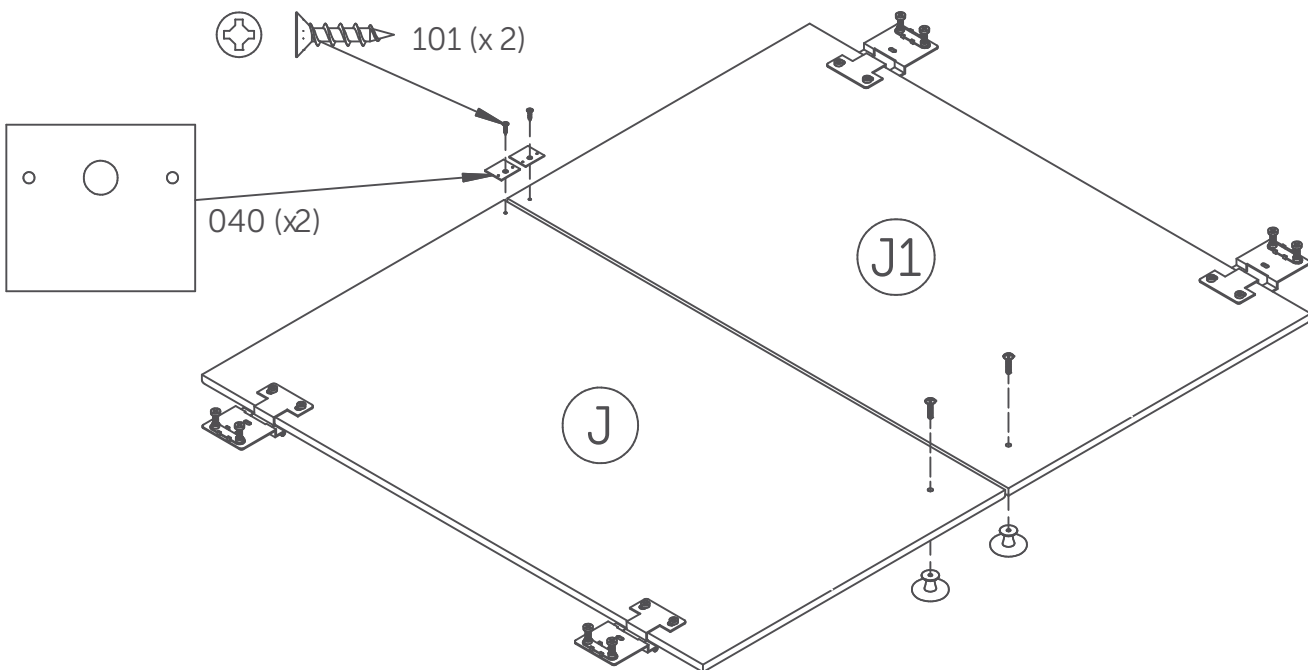

The image may differ depending on model  
 L'image peut différer selon le modèle  
 La imagen variar dependiendo del modelo

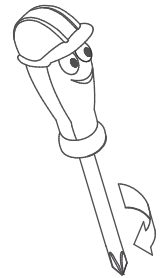
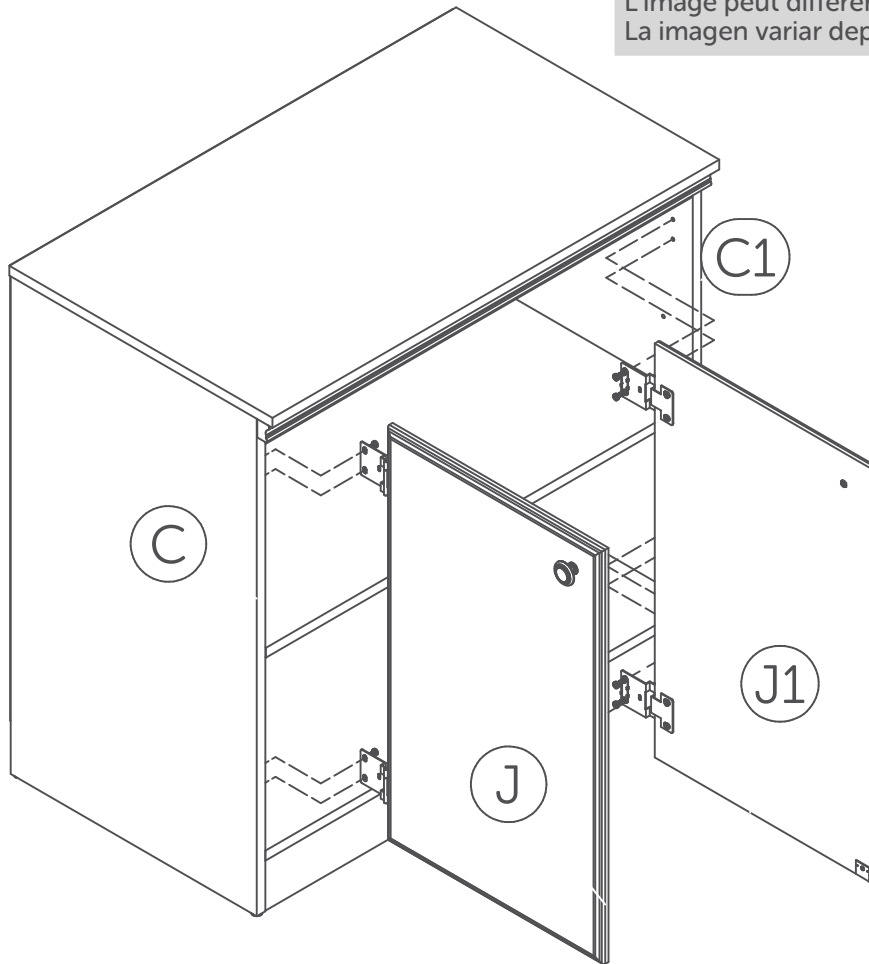

-\* Doors adjustment (Hinges)

\* Make sure the unit is level.

\* Loosen the concerned screw(s), adjust, and tighten.

-\* Ajustement des portes (Charnières)

\* Assurez-vous que le meuble soit au niveau.

\* Déserrer la(les) vis concernée(s), ajuster, et resserrer.

-\* Ajuste de las puertas (Bisagras)

\* Cerciorarse de que la unidad se encuentre a nivel.

\* Desapretar los atornillos apropiados, ajustar, y apretar.

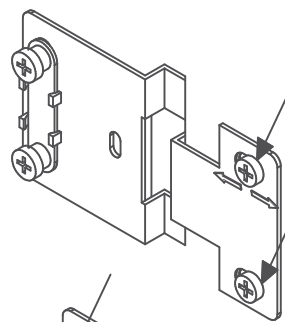

Left/Right

Gauche/Droite

Izquierda/Derecha

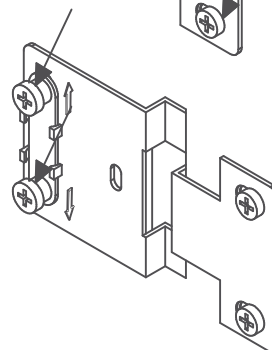
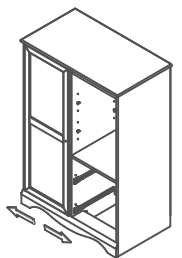

Height

Hauteur

Altura

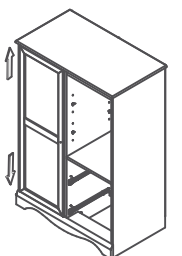

The image may differ depending on model  
L'image peut différer selon le modèle  
La imagen variar dependiendo del modelo

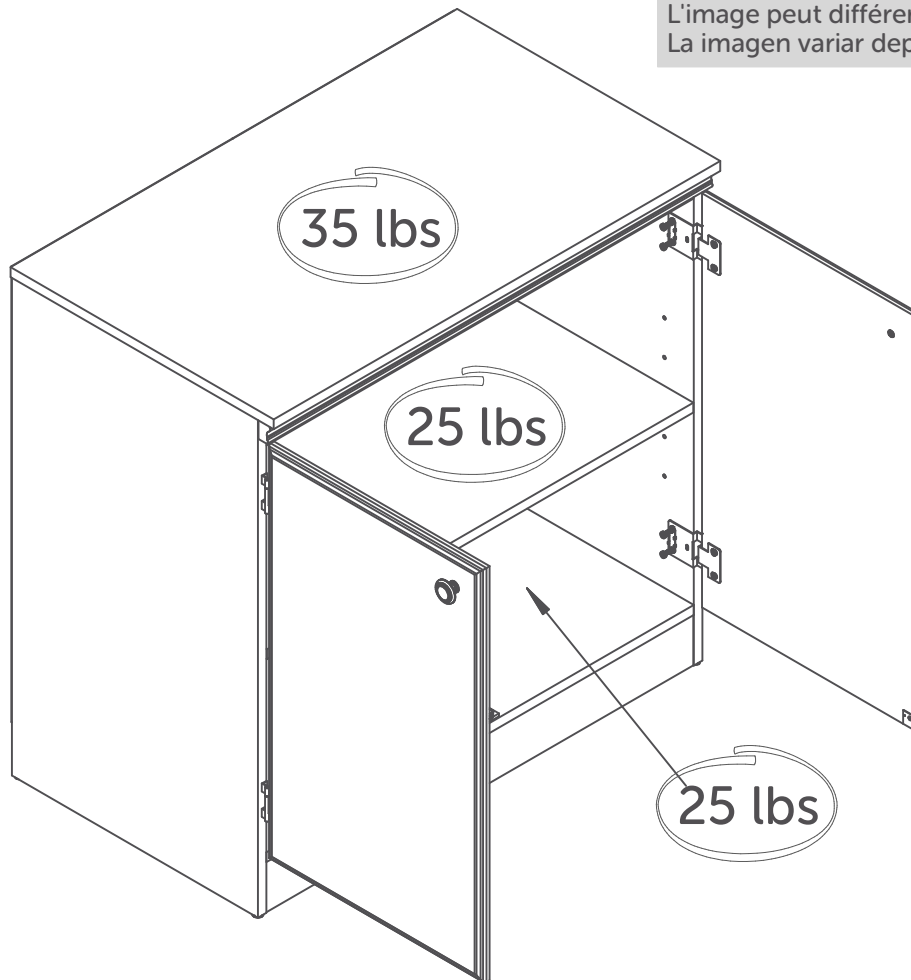

This product is designed to withstand the weight indicated on the plan. We are not responsible for the breakage of parts or any injury caused by the failure to comply with this recommendation.

Ce produit de Meubles a été conçu pour résister aux poids mentionnés ci-contre. Nous ne sommes pas responsable du bris des pièces ou de toute blessure occasionnée par le non-respect de cette recommandation.

Este producto las sido concebido para resistir el peso que se menciona aqui. No somos responsables del daño de piezas o cualquier otra lesión ocasionada por el no respeto de esta recomendación.

## MAINTENANCE TIPS

### CONSEILS D'ENTRETIEN / CONSEJOS DE MANTENIMIENTO



Never let liquids or damp cloths sit on this furniture.

Ne jamais laisser de liquide ou linge humide sur le meuble.

Nunca deje un líquido o un trapo húmedo sobre el mueble.



Never use chemical cleaning products. They can damage the finish. For cleaning, use only a slightly damp cloth and wipe dry.

Ne jamais utiliser de produits nettoyants à base de produits chimiques, cela va endommager le fini. Utiliser seulement un linge légèrement humide.

Nunca utilice limpiadores a base de químicos, estos dañaran el acabado. Use sólo un paño húmedo.

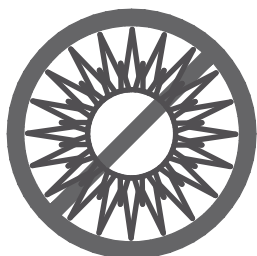

To avoid dulling of the finish, do not place furniture in direct sunlight.

Ne pas placer le meuble directement au soleil pour prévenir le ternissement.

No exponga el mueble directamente al sol para prevenir empañamiento.

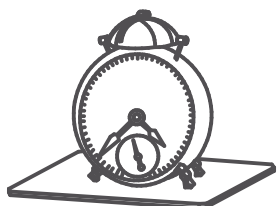

Do not put plastic or rubber rings under appliances. Use cloth or felt protectors.

Évitez de déposer des appareils avec des rondelles de plastique ou de caoutchouc. Utilisez un protecteur en tissu ou en feutre.

Evite apoyar aparatos con redondeles de plástico o de goma. Utilizar un protector de tela o de fieltro.



To clean, use a soft or slightly damp cloth, then wipe with a clean, dry cloth.

Pour nettoyer, utilisez un linge doux ou légèrement humecté. Essuyez par la suite avec un linge propre et sec.

Para limpiar, utilice un trapo suave o ligeramente humedecido. Seque luego con un trapo limpio y seco.